

**±60V Fault Tolerant
RS485/RS422 Transceiver
with Operation to 175°C**

FEATURES

- **Guaranteed Operation from -55°C to 175°C**
- **Fully Tested at 175°C**
- **Protected from Overvoltage Line Faults to ±60V**
- **±52kV ESD Interface Pins, ±15kV All Other Pins**
- **Level 4 IEC61000-4-4 Electrical Fast Transient**
- **±25V Working Common Mode Range**
- **20Mbps Maximum Baud Rate**
- **Operates with V_{CC} from 3V to 5.5V**
- PROFIBUS IEC 61158-2 Compliant (V_{CC} ≥ 4.5V)
- Fully Balanced Differential Receiver Thresholds with 240mV Hysteresis for Superior Noise Tolerance and Low Duty Cycle Distortion
- Receiver Failsafe for Open, Shorted and Terminated Conditions
- Available in a Tiny 3mm × 3mm MSOP Package

APPLICATIONS

- Oil and Gas Exploration
- High Temperature Industrial Control
- PROFIBUS-DP
- Military Systems
- Harsh Environments

DESCRIPTION

The **LTC[®]2879X** is a rugged RS485/RS422 transceiver designed to operate over a wide temperature range of -55°C to 175°C. Special processing steps are used to prevent intermetallic growth that can cause metal voids on standard parts operating at high temperatures. Low-drift, low-leakage circuitry and lack of a thermal shutdown circuit allow the LTC2879X to meet critical specifications, tested 100% at 175°C.

The LTC2879X also meets the specifications for PROFIBUS-DP (IEC 61158-2) supporting all data rates from 9.6kbps to 12Mbps.

The LTC2879X is exceptionally robust, tolerating ±60V faults on the bus pins and protected to ±52kV ESD. These devices are suitable for harsh environments or where 24V power might be inadvertently connected. Extended ±25V input common mode operating range and full failsafe operation improve data communication reliability in noisy systems.

The LTC2879X meets RS485, RS422, and PROFIBUS-DP specifications with a supply voltage of 4.5V to 5.5V with full RS485/RS422 compatibility down to 3V.

All registered trademarks and trademarks are the property of their respective owners.

TYPICAL APPLICATION

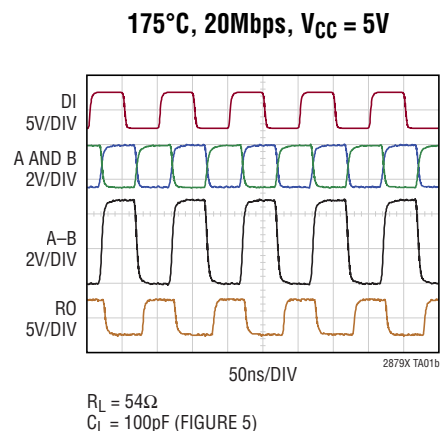
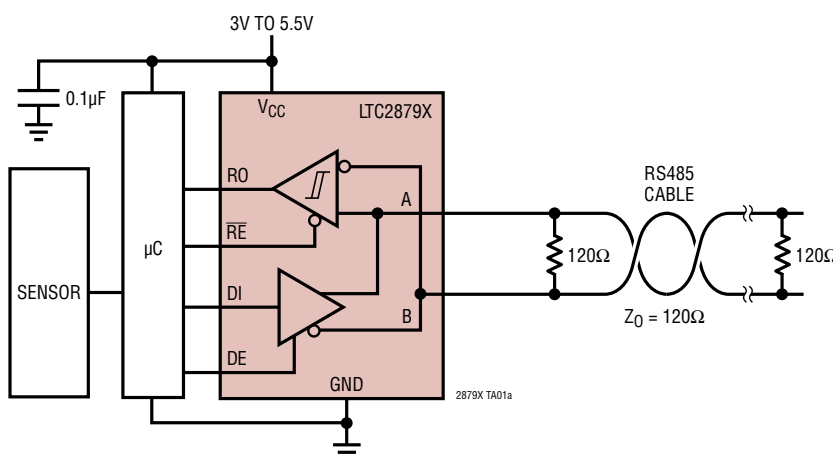

LTC2879X

ABSOLUTE MAXIMUM RATINGS

(Notes 1, 2, 5)

Supply Voltages (V_{CC})	-0.3V to 6V
Logic Input Voltages (\overline{RE} , DE, DI)	-0.3V to 6V
Line Interface I/O (A, B)	-60V to 60V
Line Interface I/O Difference (A-B)	-120V to 120V
Receiver Output (RO)	
LTC2879X	-0.3V to $V_{CC} + 0.3V$
Operating Ambient Temperature Range	
LTC2879X	-55°C to 175°C
Storage Temperature Range	-65°C to 150°C

PIN CONFIGURATION

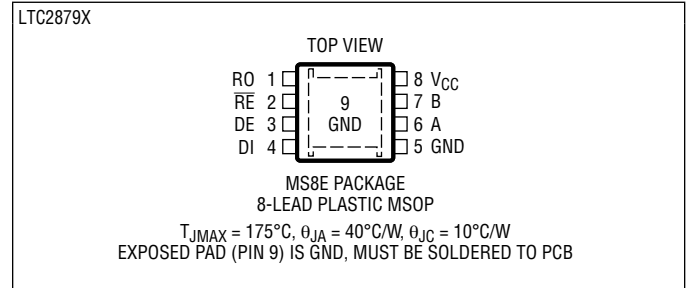

ORDER INFORMATION

<http://www.linear.com/product/LTC2879X#orderinfo>

Lead Free Finish

TUBE	TAPE AND REEL	PART MARKING	PACKAGE DESCRIPTION	TEMPERATURE RANGE
LTC2879XMS8E#PBF	LTC2879XMS8E#TRPBF	LTHFF	8-Lead Plastic MSOP	-55°C to 175°C

Consult ADI Marketing for parts specified with wider operating temperature ranges.

Consult ADI Marketing for information on nonstandard lead based finish parts.

For more information on lead free part marking, go to: <http://www.linear.com/leadfree/>

For more information on tape and reel specifications, go to: <http://www.linear.com/tapeandreel/>. Some packages are available in 500 unit reels through designated sales channels with #TRMPBF suffix.

ELECTRICAL CHARACTERISTICS

The ● denotes the specifications which apply over the full operating temperature range, otherwise specifications are at $T_A = 25^\circ\text{C}$. $V_{CC} = 5V$ unless otherwise noted.

SYMBOL	PARAMETER	CONDITIONS	MIN	TYP	MAX	UNITS	
Supplies							
V_{CC}	Primary Power Supply		●	3.0	5.5	V	
I_{CCS}	LTC2879X Supply Current in Shutdown Mode	DE = 0V, $\overline{RE} = V_{CC}$, DI = V_{CC}	●		0	50	μA
		DE = 0V, $\overline{RE} = V_{CC}$, DI = 0V	●		12	60	μA
I_{CCR}	Supply Current with Only Receiver Enabled	No Load, DE = 0V, $\overline{RE} = 0V$	●		600	900	μA
I_{CCD}	Supply Current with Only Driver Enabled	No Load, DE = $\overline{RE} = V_{CC}$	●		700	1100	μA
I_{CCDR}	Supply Current with Both Driver and Receiver Enabled	No Load, DE = V_{CC} , $\overline{RE} = 0V$	●		750	1200	μA
Driver							
$ V_{OD(485)} $	RS485 Differential Driver Output Voltage, in Either Logic State	Figure 1 with No Load	●			V_{CC}	V
		$R_L = 27\Omega, V_{CC} = 4.5V$ to $5.5V$ (Figure 1)	●	1.5		3.4	V
		$R_L = 27\Omega, V_{CC} = 3.0V$ to $3.6V$ (Figure 1)	●	0.8		1.8	V
$ V_{OD(422)} $	RS422 Differential Driver Output Voltage, Either Logic State	Figure 1 with No Load	●			V_{CC}	V
		$R_L = 50\Omega, V_{CC} = 4.5V$ to $5.5V$ (Figure 1)	●	2		4	V
		$R_L = 50\Omega, V_{CC} = 3.0V$ to $3.6V$ (Figure 1)	●	1		2	V

Rev 0

ELECTRICAL CHARACTERISTICS

The ● denotes the specifications which apply over the full operating temperature range, otherwise specifications are at $T_A = 25^\circ\text{C}$. $V_{CC} = 5\text{V}$ unless otherwise noted.

SYMBOL	PARAMETER	CONDITIONS	MIN	TYP	MAX	UNITS
$\Delta V_{OD(485)} $, $\Delta V_{OD(422)} $	RS485, RS422 Change in Magnitude of Driver Differential Output Voltage	$R_L = 27\Omega$ (RS485) or $R_L = 50\Omega$ (RS422) (Figure 1)	●		0.2	V
$V_{OC(485)}$, $V_{OC(422)}$	RS485, RS422 Driver Common-Mode Output Voltage	$R_L = 27\Omega$ (RS485) or $R_L = 50\Omega$ (RS422) (Figure 1)	●		3	V
$\Delta V_{OC(485)} $, $\Delta V_{OC(422)} $	RS485, RS422 Change in Magnitude of Driver Common-Mode Output Voltage	$R_L = 27\Omega$ (RS485) or $R_L = 50\Omega$ (RS422) (Figure 1)	●		0.2	V
$V_{OD(PP)}$	Differential Bus Output Voltage ($B' - A'$) with PROFIBUS Load	PROFIBUS LOAD (Figure 2) $R_{CABLE} = 0\Omega$, $V_{CC} = 4.5\text{V}$ to 5.5V $R_{CABLE} = 5.5\Omega$, $V_{CC} = 4.5\text{V}$ to 5.5V $R_{CABLE} = 11\Omega$, $V_{CC} = 4.75\text{V}$ to 5.5V	● ● ●	4 4 4	7 7 7	$V_{P-P(DIFF)}$ $V_{P-P(DIFF)}$ $V_{P-P(DIFF)}$
$V_{BPP-APP}$	Single-Ended Bus Output Amplitude Difference ($B'_{PP} - A'_{PP}$)	All of the Conditions Above	●		0.5	V
$V_{BPP+APP}$	Single-Ended Bus Output Amplitude Sum $ B'_{PP} + A'_{PP} $	All of the Conditions Above	●	4		V
	Differential Capacitance (A to B) (Note 3)	Powered, $V_{CC} = 5\text{V}$ Unpowered, $V_{CC} = 0\text{V}$		7 12		pF pF
I_{OSD}	Maximum Driver Short-Circuit Current	$-60\text{V} \leq (A \text{ or } B) \leq 60\text{V}$ (Figure 3)	●	± 150	± 250	mA
Receiver						
I_{IN}	Input Current (A, B)	$V_{CC} = 0\text{V}$ or 5V , $V_{BUS} = 12\text{V}$ (Figure 4) $V_{CC} = 0\text{V}$ or 5V , $V_{BUS} = -7\text{V}$ (Figure 4)	● ●	-194	333	μA μA
R_{IN}	Input Resistance	$V_{BUS} = -25\text{V}$ or 25V (Figure 4)	●	36	112	135 k Ω
V_{CM}	Common Mode Input Voltage (A+B)/2 for Data Reception		●		± 25	V
V_{TS+}	Differential Input Signal Threshold Voltage (A-B) Rising	$-25\text{V} \leq V_{CM} \leq 25\text{V}$, Edge Rates $> 100\text{mV}/\mu\text{s}$ (Note 4) (Figure 12)	●	40	120	200 mV
V_{TS-}	Differential Input Signal Threshold Voltage (A-B) Falling	$-25\text{V} \leq V_{CM} \leq 25\text{V}$, Edge Rates $> 100\text{mV}/\mu\text{s}$ (Note 4) (Figure 12)	●	-40	-120	-200 mV
ΔV_{TS}	Differential Input Signal Hysteresis	Edge Rates $> 100\text{mV}/\mu\text{s}$ (Note 4) (Figure 12)			240	mV
V_{TFS+}	Differential Input Failsafe Threshold Voltage (A-B) Rising	$-25\text{V} \leq V_{CM} \leq 25\text{V}$, DC Bus Voltages (Figure 12)	●	-10	-75	-200 mV
V_{TFS-}	Differential Input Failsafe Threshold Voltage (A-B) Falling	$-25\text{V} \leq V_{CM} \leq 25\text{V}$, DC Bus Voltages (Figure 12)	●	-40	-120	-200 mV
ΔV_{TFS}	Differential Input Failsafe Hysteresis	DC Bus Voltages (Figure 12)			45	mV
V_{OH}	Receiver Output High Voltage	$V_{CC} \geq 3.0\text{V}$, $I(RO) = -3\text{mA}$	●	$V_{CC} - 0.4\text{V}$		V
V_{OL}	Receiver Output Low Voltage	$V_{CC} \geq 3.0\text{V}$, $I(RO) = 3\text{mA}$	●		0.4	V
	Receiver Three-State (High Impedance) Output Current on RO	$\overline{RE} = \text{High}$, $RO = 0\text{V}$	●	-20	-40	μA
	Receiver Three-State (High Impedance) Output Current on RO	$\overline{RE} = \text{High}$, $RO = V_{CC}$	●	0	5	μA
	Receiver Short-Circuit Current	$\overline{RE} = \text{Low}$, $RO = 0\text{V}$ or V_{CC}	●	± 12	± 20	mA
Logic						
	Low Level Input Voltage (DE, DI, \overline{RE})	$3.0 \leq V_{CC} \leq 5.5\text{V}$	●		$0.25 \cdot V_{CC}$	V
	High Level Input Voltage (DE, DI, \overline{RE})	$3.0 \leq V_{CC} \leq 5.5\text{V}$	●	$0.75 \cdot V_{CC}$		V
	Logic Input Current Low (DE)	DE = 0V	●	0	-5	μA
	Logic Input Current Low (DI, \overline{RE})	DI or $\overline{RE} = 0\text{V}$	●	-3	-10	-20 μA
	Logic Input Current High (DE)	DE = V_{CC}	●	3	10	20 μA
	Logic Input Current High (DI, \overline{RE})	(DI, $\overline{RE}) = V_{CC}$	●	0	5	μA

Rev 0

ELECTRICAL CHARACTERISTICS

The ● denotes the specifications which apply over the full operating temperature range, otherwise specifications are at $T_A = 25^\circ\text{C}$. $V_{CC} = 5\text{V}$ unless otherwise noted.

SYMBOL	PARAMETER	CONDITIONS	MIN	TYP	MAX	UNITS
ESD (Note 3)						
	ESD Protection Level of Interface Pins (A, B)	Human Body Model to GND or V_{CC} Powered or Unpowered		±26		kV
		Human Body Model to GND, Unpowered		±52		kV
	ESD Protection Level of All Other Pins (DE, DI, \overline{RE} , V_{CC})	Human Body Model		±15		kV

SWITCHING CHARACTERISTICS

The ● denotes the specifications which apply over the full operating temperature range, otherwise specifications are at $T_A = 25^\circ\text{C}$. $V_{CC} = 5\text{V}$ unless otherwise noted.

SYMBOL	PARAMETER	CONDITIONS	MIN	TYP	MAX	UNITS
f_{MAX}	Maximum Data Rate	(Note 3)	●	20		Mbps
Driver						
t_{PLHD} , t_{PHLD}	Driver Input to Output	$V_{CC} = 3.3\text{V}$ or 5V (Figure 5)	●	13	50	ns
Δt_{PD}	Driver Input to Output Difference $ t_{PLHD} - t_{PHLD} $	(Figure 5)	●	2	9	ns
t_{SKEWD}	Driver Output A to Output B	(Figure 5)	●		±9	ns
t_{RD} , t_{FD}	Driver Rise or Fall Time	$V_{CC} = 3.3\text{V}$ or 5V (Figure 5)	●	4	16	ns
t_{ZLD} , t_{ZHD} , t_{LZD} , t_{HZD}	Driver Enable or Disable Time	$\overline{RE} = 0\text{V}$ (Figure 6)	●		180	ns
t_{ZHSD} , t_{ZLSR}	Driver Enable from Shutdown	$\overline{RE} = \text{High}$ (Figure 6)	●		15	μs
t_{SHDND}	Time to Shutdown with DE	$\overline{RE} = \text{High}$ (Figure 6)	●		180	ns
Receiver						
t_{PLHR} , t_{PHLR}	Receiver Input to Output	$V_{CM} = 2.25\text{V}$, $(A-B) = \pm 1.5\text{V}$, t_R and $t_F < 4\text{ns}$, $V_{CC} = 3.3\text{V}$ or 5V (Figure 7)	●	50	75	ns
Δt_{PR}	Receiver Input to Output Difference $ t_{PLHR} - t_{PHLR} $	(Figure 7)	●	2	14	ns
t_{ZLR} , t_{ZHR} , t_{LZR} , t_{HZR}	Receiver Enable/Disable Time	DE = High (Figure 8)	●		40	ns
t_{ZHSR} , t_{ZLSR}	Receiver Enable from Shutdown	DE = 0V, (Figure 9)	●		9	μs
t_{SHDNR}	Time to Shutdown with \overline{RE}	DE = 0V, (Figure 9)	●		40	ns

Note 1: Stresses beyond those listed under Absolute Maximum Ratings may cause permanent damage to the device. Exposure to any Absolute Maximum Rating condition for extended periods may affect device reliability and lifetime.

Note 2: All currents into device pins are positive; all currents out of device pins are negative. All voltages are referenced to device ground unless otherwise specified.

Note 3: Not tested in production.

Note 4: The dependency on edge rate is tested indirectly.

Note 5: The LTC2879X is guaranteed over the full -55°C to 175°C operating temperature range. High junction temperatures degrade operating lifetimes. Operating lifetime is derated at junction temperatures greater than 125°C . The LTC2879X has no thermal shutdown.

TYPICAL PERFORMANCE CHARACTERISTICS

$T_A = 25^\circ\text{C}$. $V_{CC} = 5\text{V}$, unless otherwise noted. (Note 2)

V_{CC} Supply Current vs Voltage for Various Modes, No Load

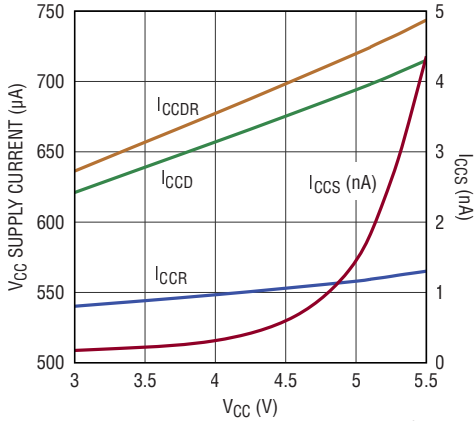

2879X G01

V_{CC} Supply Current vs Temperature for Various Modes, No Load

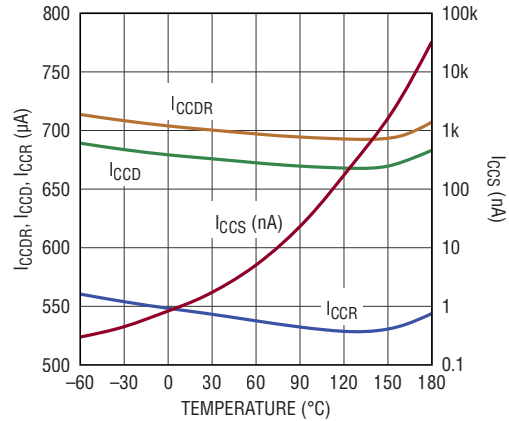

2879X G02

V_{CC} Supply Current vs Data Rate

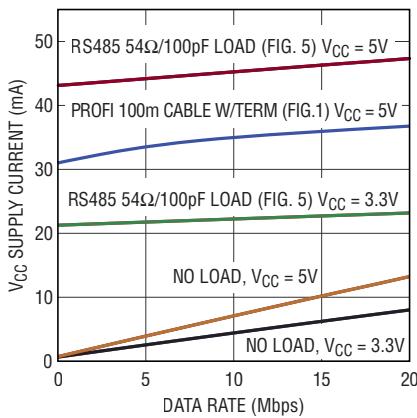

2879X G03

Driver Differential Output Voltage vs Supply Voltage

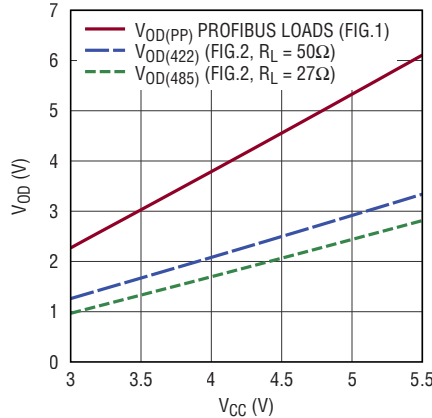

2879X G04

Driver Differential Output Voltage vs Temperature

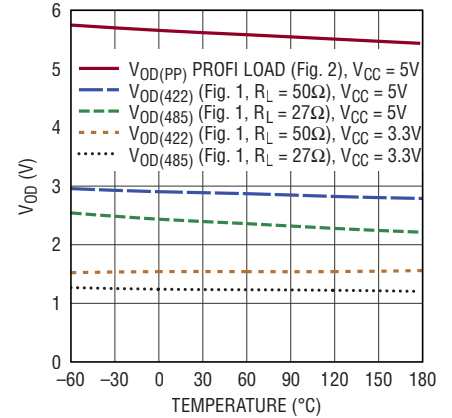

2879X G05

Driver Output Low/High Voltage vs Output Current

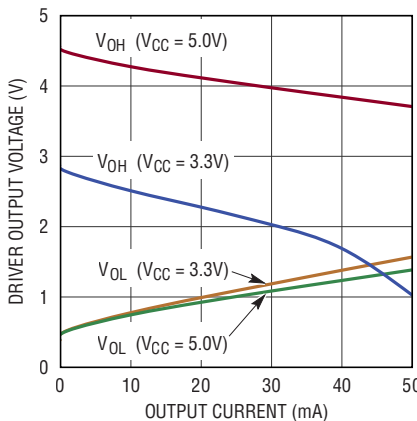

2879X G06

Driver Output Short-Circuit Current vs Voltage

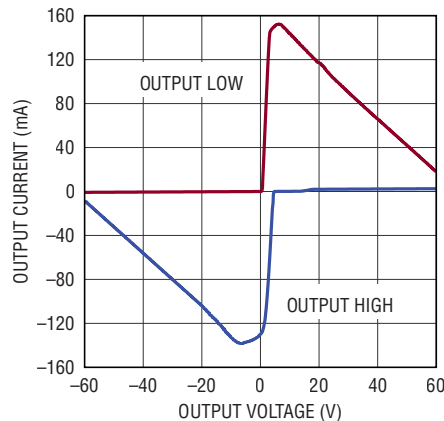

2879X G07

Driver and Receiver Propagation Delay vs V_{CC}

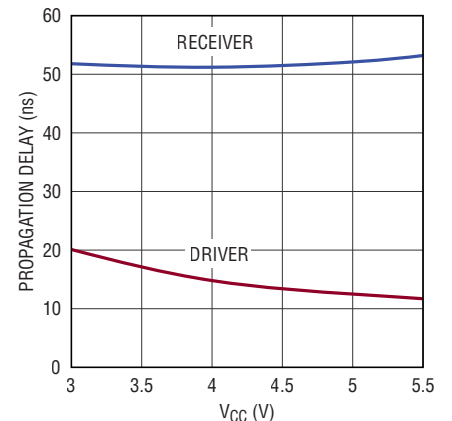

2879X G08

TYPICAL PERFORMANCE CHARACTERISTICS

$T_A = 25^\circ\text{C}$. $V_{CC} = 5\text{V}$, unless otherwise noted. (Note 2)

Driver Propagation Delay vs Temperature

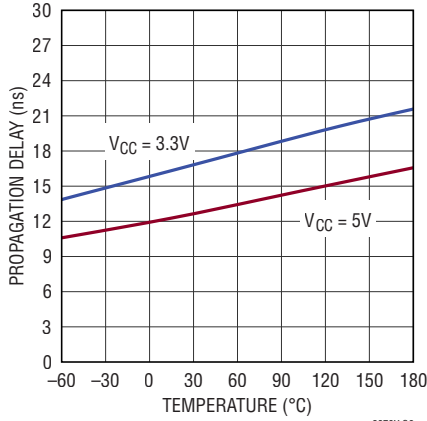

2879X G9

Driver Output Skew vs Temperature

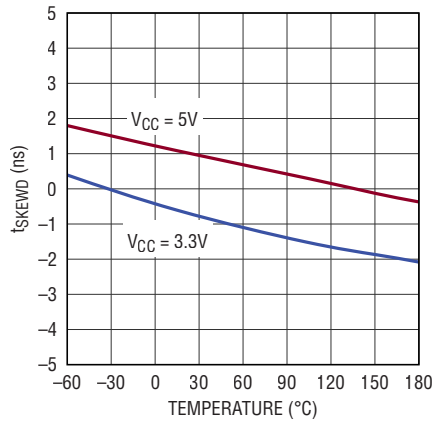

2879X G10

Driver Output Propagation Delay Difference vs Temperature

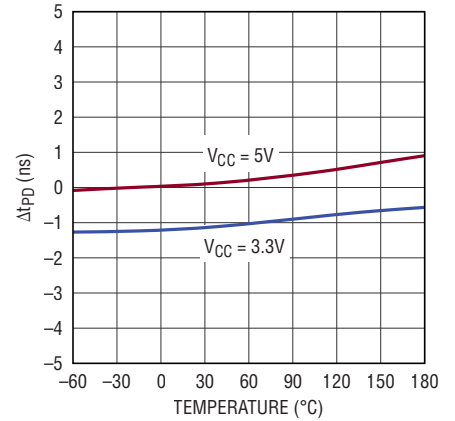

2879X G11

Receiver Propagation Delay vs Temperature

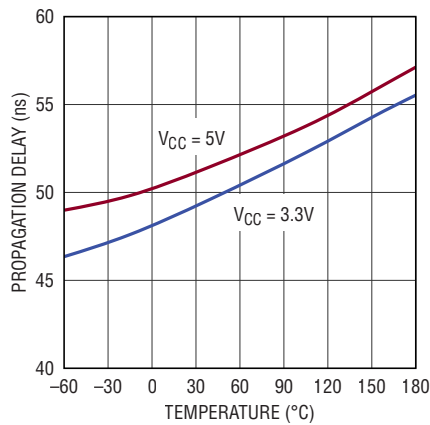

2879X G12

Receiver Propagation Delay Difference vs Temperature

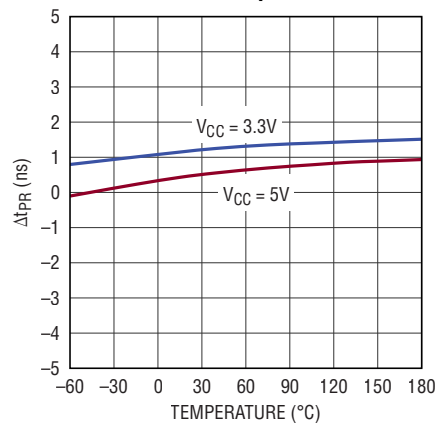

2879X G13

Receiver Output Voltage vs Output Current (Source and Sink)

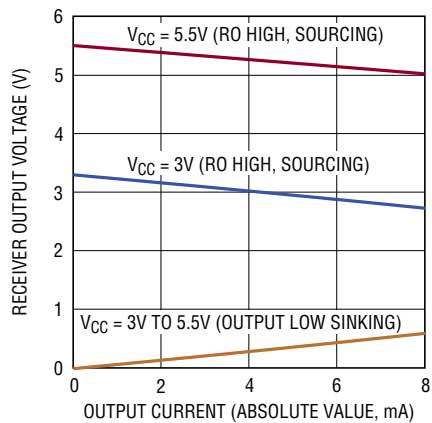

2879X G14

Receiver Output Voltage vs V_{CC} Voltage

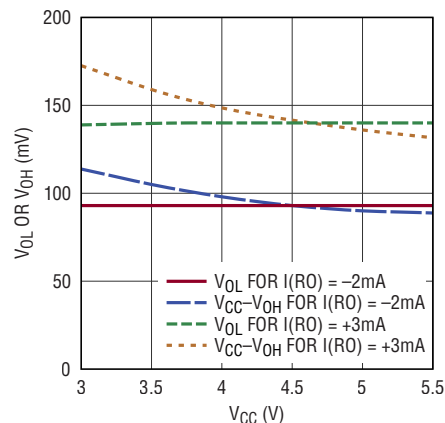

2879X G15

TYPICAL PERFORMANCE CHARACTERISTICS

$T_A = 25^\circ\text{C}$. $V_{CC} = 5\text{V}$, unless otherwise noted. (Note 2)

175°C, 12Mbps, $V_{CC} = 3.3\text{V}$

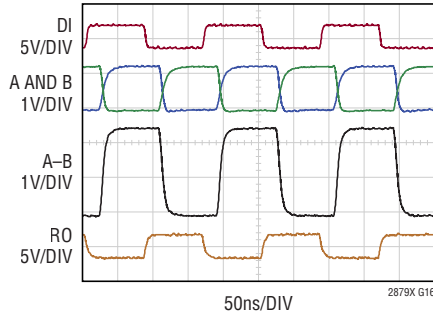

$R_L = 54\Omega$
 $C_L = 100\text{pF}$ (FIGURE 5)

175°C, 12Mbps, $V_{CC} = 5\text{V}$

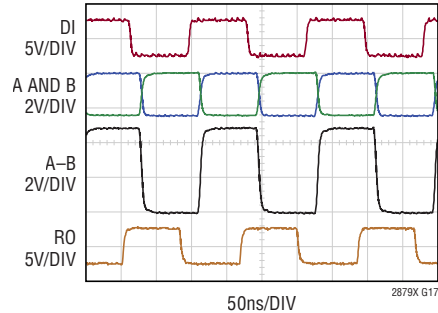

$R_L = 54\Omega$
 $C_L = 100\text{pF}$ (FIGURE 5)

175°C, 20Mbps, $V_{CC} = 3.3\text{V}$

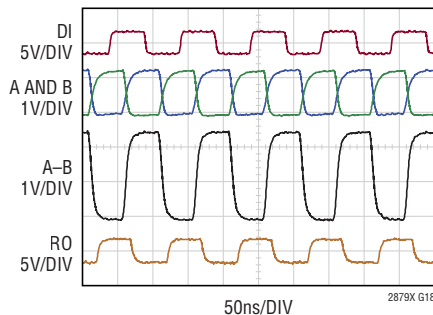

$R_L = 54\Omega$
 $C_L = 100\text{pF}$ (FIGURE 5)

50°C, 20Mbps, $V_{CC} = 3.3\text{V}$

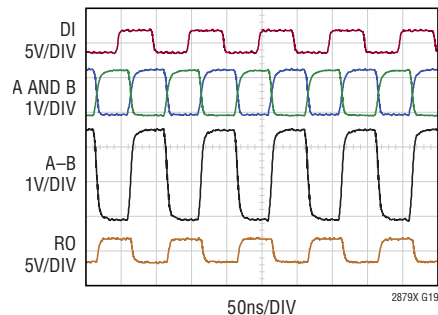

$R_L = 54\Omega$
 $C_L = 100\text{pF}$ (FIGURE 5)

PROFIBUS Operation at 12Mbps
 $V_{CC} = 5\text{V}$

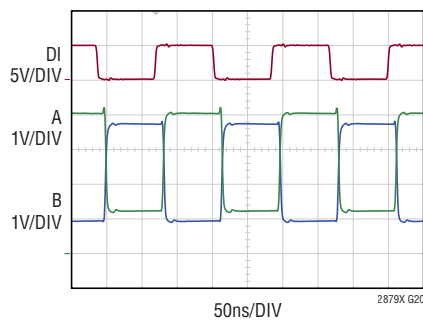

DOUBLE PROFIBUS TERMINATION
 $R_{CABLE} = 0\Omega$ (FIGURE 1)

Eye Diagram of 12Mbps PRBS Signal at
Both Ends of 100m PROFIBUS Cable

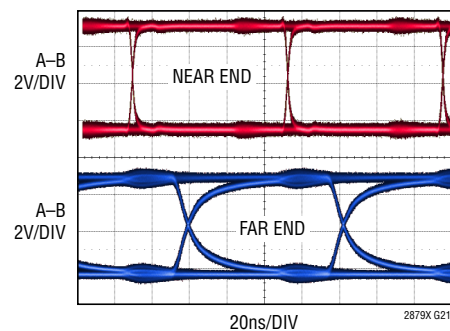

PIN FUNCTIONS

RO (Pin 1): Receiver Output. If the receiver is enabled (\overline{RE} low) and $A-B > 200\text{mV}$, then RO will be high. If $A-B < -200\text{mV}$, then RO will be low. If the receiver inputs are open, shorted, or terminated without being driven for more than about $1.5\mu\text{s}$, RO will be high. Integrated 250k pull-up resistor to supply.

\overline{RE} (Pin 2): Receiver Enable. A low input enables the receiver. A high input forces the receiver output into a high impedance state. If \overline{RE} is high with DE low, the device enters a low power shutdown state. Integrated 500k pull-up resistor to supply.

DE (Pin 3): Driver Enable. A high input on DE enables the driver. A low input forces the driver outputs into a high impedance state. If DE is low with \overline{RE} high, the device enters a low power shutdown state. Integrated 500k pull-down resistor to ground.

DI (Pin 4): Driver Input. If the driver outputs are enabled (DE high), then a low on DI drives a negative differential voltage between A and B. A high on DI, with the driver outputs enabled, drives a positive differential voltage between A and B. Integrated 500k pull-up resistor to supply.

GND (Pin 5, 9): Ground

A (Pin 6): Non-Inverting Receiver Input and Non-Inverting Driver Output. For use in a PROFIBUS network, connect this to the B wire (red, positive).

B (Pin 7): Inverting Receiver Input and Inverting Driver Output. For use in a PROFIBUS network, connect this to the A wire (green, negative).

V_{CC} (Pin 8): Power Supply. $3.0\text{V} \leq V_{CC} \leq 5.5\text{V}$. Bypass with a $0.1\mu\text{F}$ ceramic capacitor to GND.

Exposed Pad (Pin 9): Must be connected to GND.

BLOCK DIAGRAM

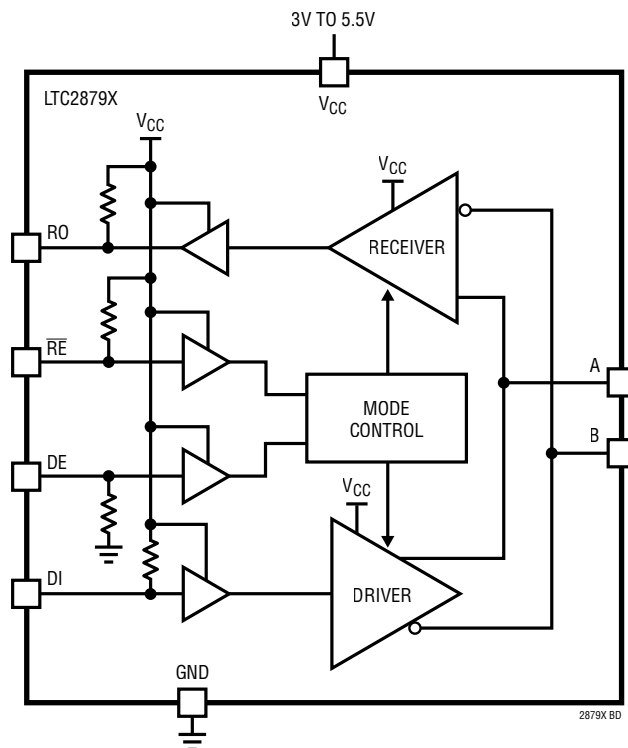

TEST CIRCUITS

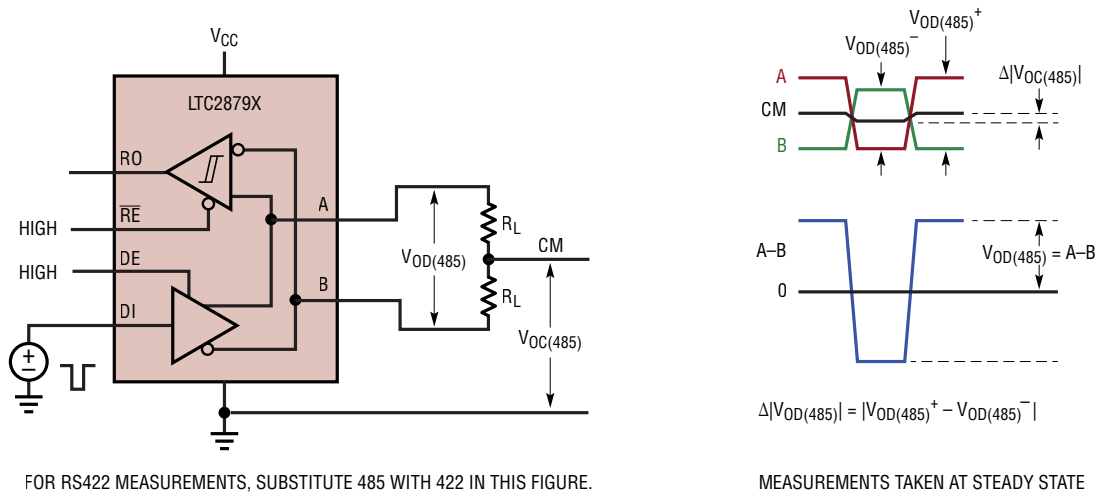

2879X F01

Figure 1. Driver Output Voltages in RS485 and RS422 Configurations

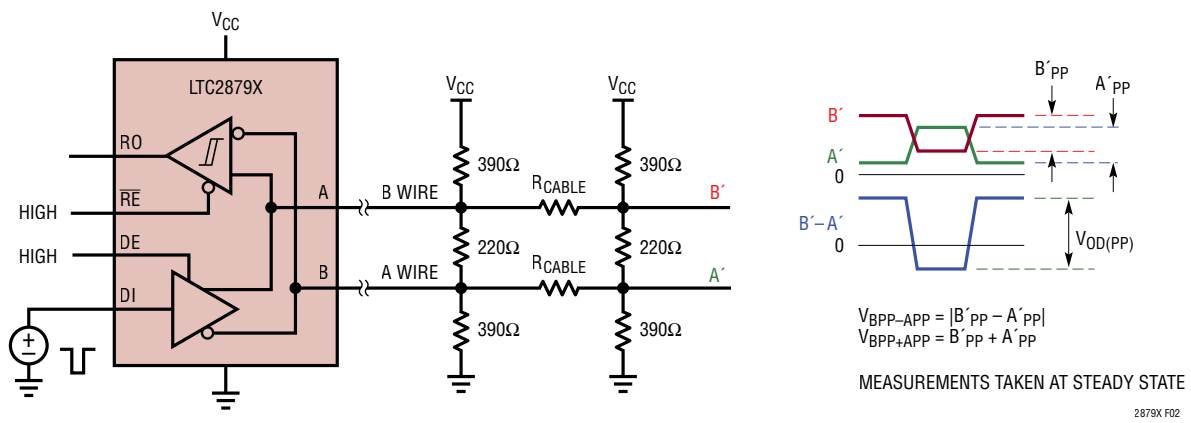

2879X F02

Figure 2. Driver Differential Output Voltages for PROFIBUS Load

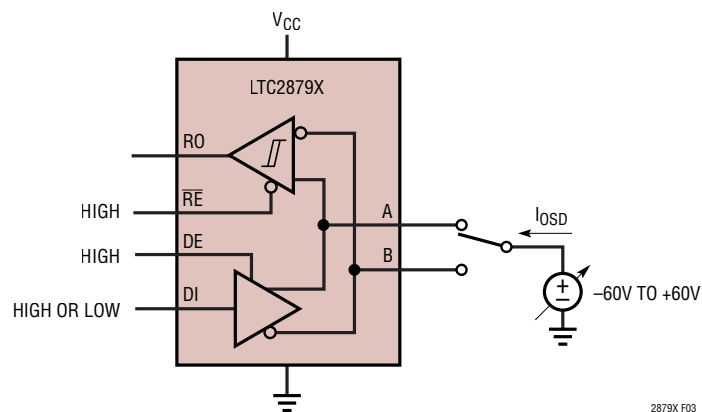

2879X F03

Figure 3. Driver Output Short-Circuit Current

TEST CIRCUITS

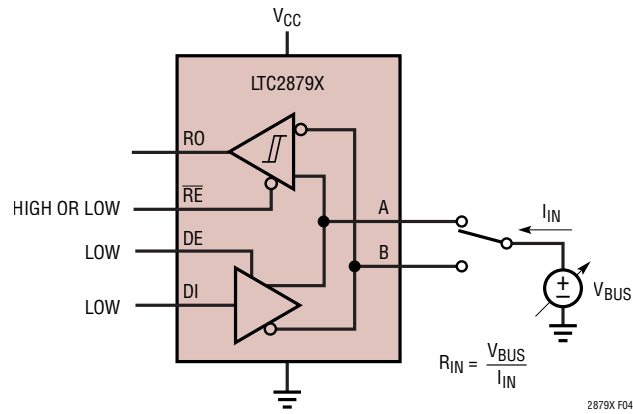

Figure 4. Receiver Input Current and Input Resistance

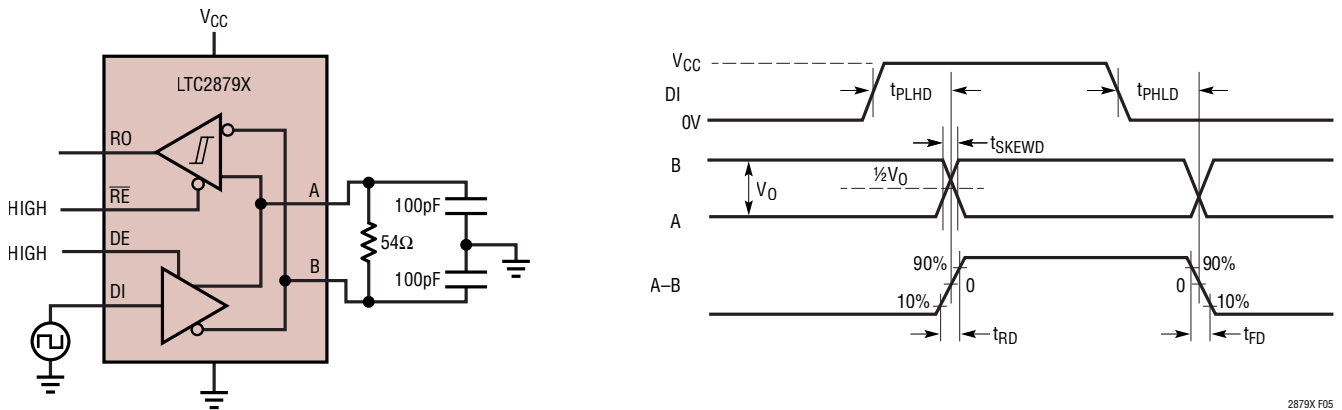

Figure 5. Driver Timing Measurement

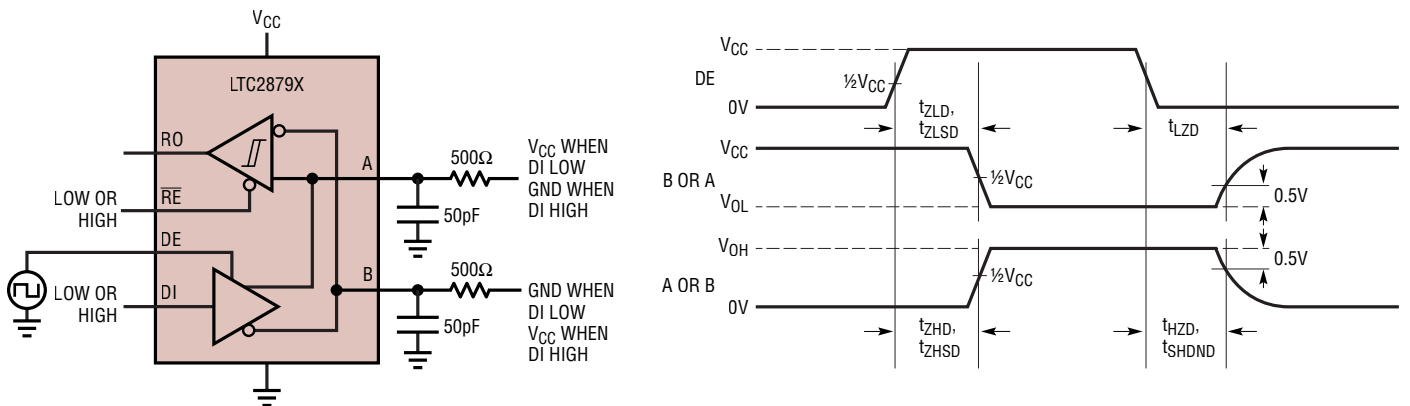
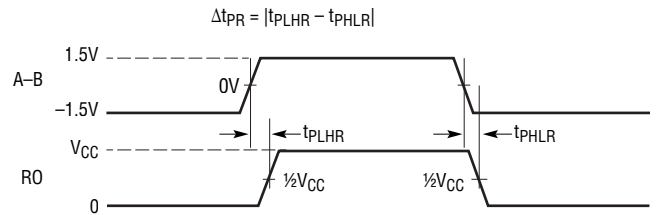
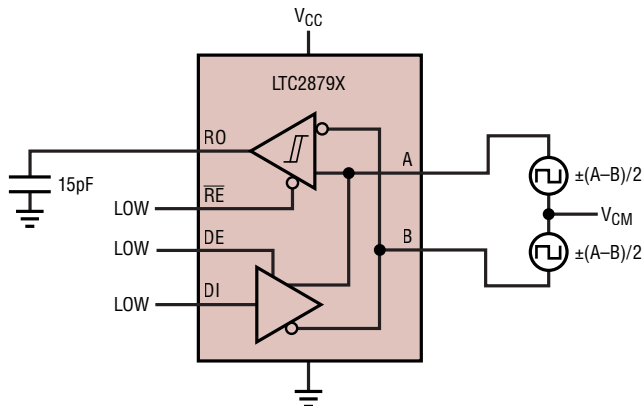

Figure 6. Driver Enable, Disable and Shutdown Timing Measurements

TEST CIRCUITS



2879X F07

Figure 7. Receiver Propagation Delay Measurements

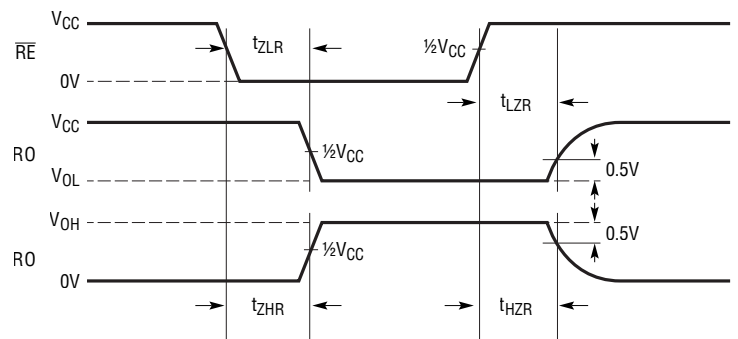
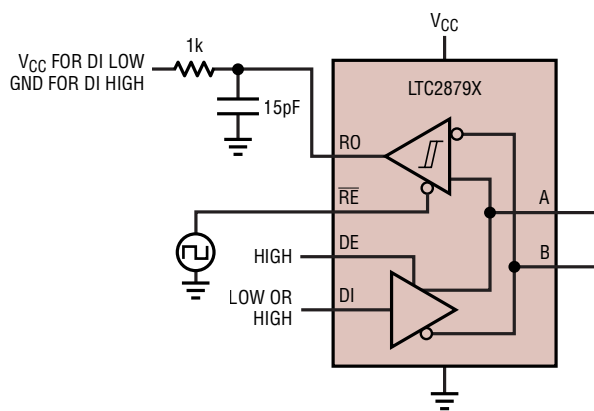

2879X F08

Figure 8. Receiver Enable and Disable Timing Measurements

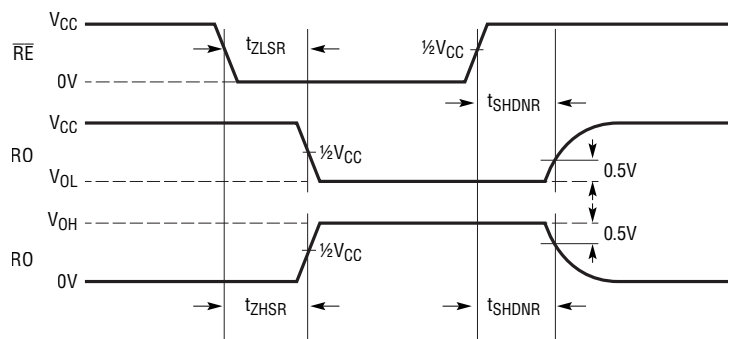
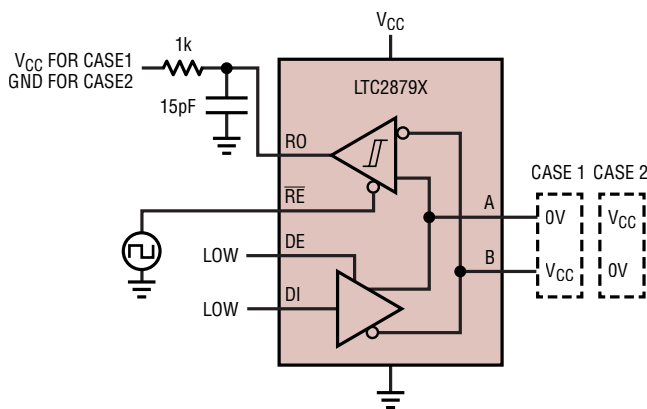

2879X F09

Figure 9. Receiver Shutdown Timing Measurements

APPLICATIONS INFORMATION

Note: Specifications in this section represent typical values unless otherwise noted.

RS485/RS422 FOR HIGH TEMPERATURE APPLICATIONS

RS485/RS422 offers high speed differential signaling for robust communication between multiple devices over long distances in noisy environments.

The LTC2879X was designed to operate in temperatures from -55°C to 175°C , making it suitable for use in harsh environments such as down-hole drilling and high temperature industrial applications.

The LTC2879X is manufactured using special processing steps to prevent intermetallic growth that can cause metal voids on standard parts operating at high temperatures. Low-drift, low-leakage circuitry and lack of a thermal shutdown circuit allow the LTC2879X to meet critical specifications, tested 100% at 175°C .

High Temperature Operating Life (HTOL), per JEDEC JESD22, is used in the LTC2879X qualification to ensure reliable high temperature performance. HTOL units passed 3000 hours operating at 175°C , with no fails.

DRIVER

The driver is enabled when the LTC2879X is powered up and DE is high. The polarity of A–B follows that of DI. That is, when DI is high, A drives to a voltage that is greater than B. If DI is low, B is higher than A. When the driver is disabled with DE low, both outputs are high impedance and the overall pin resistance is dominated by the receiver inputs sharing pins A and B.

Driver Overvoltage and Overcurrent Protection

The LTC2879X driver outputs A and B are protected from short circuits to any voltage within the absolute maximum range of -60V to $+60\text{V}$, with a maximum differential voltage of -120V to $+120\text{V}$. The maximum short-circuit current to any voltage within this range is $\pm 250\text{mA}$. The driver includes a progressive foldback current limiting circuit

that continuously reduces the driver current limit with increasing output short circuit voltage to better manage power dissipation and heating effects (see plot in Typical Performance Characteristics section).

RECEIVER

The receiver provides full RS485/RS422 and PROFIBUS compatibility. When enabled, the state of RO reflects the polarity of (A–B). When the receiver is disabled, the output is high impedance and RO weakly pulled high to VCC through an internal 250k pull-up resistor.

High Receiver Input Resistance Permits 96 Nodes

The RS485 and PROFIBUS specifications allows for up to 32 devices, each contributing one unit load, to be connected together in one network. The A/B input current of the LTC2879X is guaranteed to be $3\times$ lower than the standard, over the entire temperature range, permitting a total of 96 LTC2879X devices in a contiguous network.

$\pm 25\text{V}$ Extended Common Mode Range

The LTC2879X receiver features an extended operating common mode range of -25V to $+25\text{V}$. The wide common mode increases the reliability of operation in environments with high common mode voltages created by electrical noise or local ground potential differences due to ground loops. This extended common mode range allows the LTC2879X to transmit and receive under conditions that would cause data errors or possible device damage in competing products.

Balanced Signal Threshold

The LTC2879X differential threshold is 120mV for rising input signals and -120mV for falling signals. This constitutes 240mV of hysteresis, which offers a high rejection to signal noise that can otherwise falsely trip the receiver. Since these thresholds are centered around zero volts (i.e. “balanced”), the duty cycle is preserved for small amplitude signals with slewed edges—typical of what is observed at the end of a long cable. Figure 10 illustrates this point.

APPLICATIONS INFORMATION

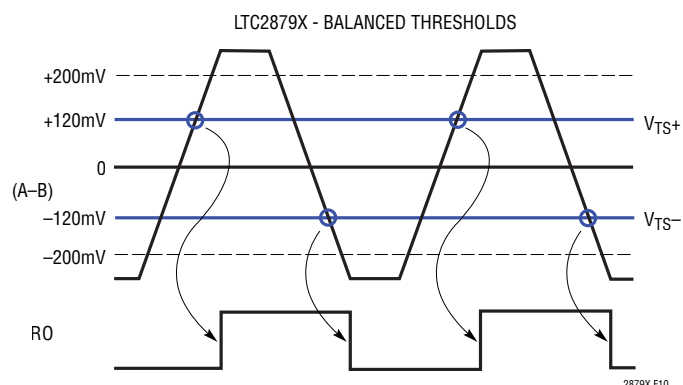

Figure 10. The LTC2879X Balanced Signal Threshold Voltages Preserve the Duty Cycle of an Incoming Signal. The Differential Signal Received (Top) Has a Duty Cycle of 50%, and Is Reflected in the Receiver Output, RO (Bottom)

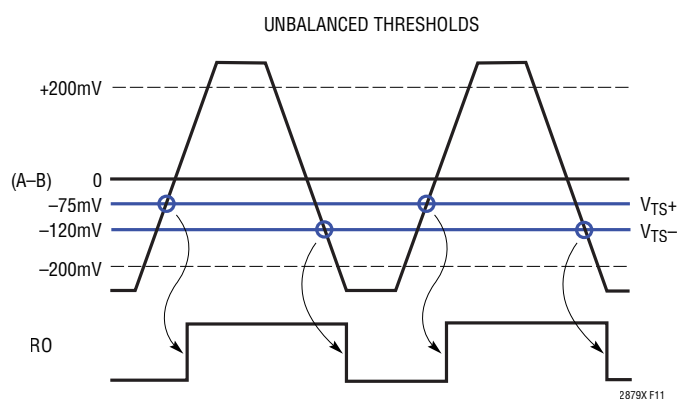

Figure 11. Typical Competitor Unbalanced Signal Threshold Voltages Distort the Duty Cycle of an Incoming Signal. Input Is 50% Duty Cycle (Top) but the Receiver Output Is Not 50% Duty Cycle (Bottom)

In contrast to this, some RS485 receivers have an unbalanced receiver threshold, used to address failsafe conditions (see Failsafe Operation section). That is, the rising and falling differential signal thresholds are both negative. Figure 11 illustrates an example where the rising threshold is -75mV and falling threshold is -120mV . This has two disadvantages. First, the hysteresis is only 45mV in this example, reducing the tolerance to noise, compared to the 240mV of hysteresis in the LTC2879X. Secondly, these unbalanced thresholds cause a duty cycle or pulse width distortion at the receiver output relative to the input signal. Figure 11 illustrates how a competitor part, using the negative thresholds in this example introduces a duty cycle distortion that becomes increasingly worse with low input signal levels and slow input edge rates.

Failsafe Operation

The LTC2879X has a failsafe feature that guarantees the receiver output will be in a logic 1 state (the idle state) when the inputs are shorted, left open, or terminated but not driven for more than about $1.5\mu\text{s}$. This failsafe feature is guaranteed to work for inputs spanning the entire common mode range of -25V to $+25\text{V}$.

Failsafe operation is performed with a window comparator to determine when the differential input voltage falls between the rising and falling signal thresholds (V_{TS+} , and V_{TS-}). If this condition persists for more than about $1.5\mu\text{s}$ then the receiver switches over to using the failsafe thresholds (V_{TFS-} , V_{TFS+}), as illustrated in Figure 12. The delay allows normal data signals to transition through the threshold region without being interpreted as a failsafe condition, and thus maintaining the benefits of a balanced threshold receiver.

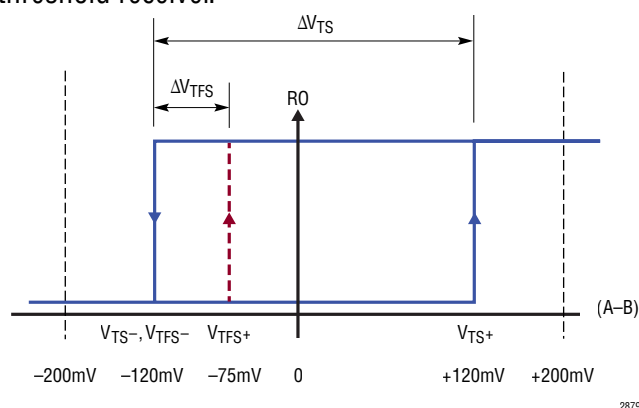

Figure 12. The LTC2879X Signal Thresholds (V_{TS-} , V_{TS+}) and Failsafe Thresholds (V_{TFS-} , V_{TFS+})

SHUTDOWN MODE DELAY

The LTC2879X features a low power shutdown mode that is entered when both the driver and receiver are simultaneously disabled (pin DE low and RE high). A shutdown mode delay of approximately 250ns (not tested in production) is imposed after the state is received before the chip enters shutdown. If either DE goes high or RE goes low during this delay, the delay timer is reset and the chip does not enter shutdown. This reduces the chance of accidentally entering shutdown if DE and RE are driven in parallel by a slowly changing signal or if DE and RE are

APPLICATIONS INFORMATION

driven by two independent signals with a timing skew between them.

This shutdown mode delay does not affect the outputs of the transmitter and receiver, which start to switch to the high impedance state upon the reception of their respective disable signals as defined by the parameters t_{SHDND} and t_{SHDNR} . The shutdown mode delay affects only the time when all the internal circuits that draw DC power from V_{CC} are turned off.

POWER-UP/DOWN GLITCH-FREE OUTPUTS

The LTC2879X employs an undervoltage detection circuit to control the activation of the on-chip circuitry. During power-up, A, B, and RO are undriven, until the V_{CC} supply reaches a voltage sufficient to reliably operate the chip. In this mode, only the internal pull-up resistor on RO and the receiver input resistance to ground on A and B offer weak conduction paths at those pins. As the supply voltage rises above the undervoltage threshold, and if the device is configured for drive mode, the A and B pins become active and are driven to a state that reflects the input condition on DI. Likewise, if the device is configured for receive mode, the RO pin is driven high or low to reflect the state of the differential voltage across A–B.

During power down, the reverse occurs; the supply undervoltage detection circuit senses low supply voltage

and immediately puts the chip into shutdown. The driver and receiver outputs go to the undriven state. RO is pulled up through the internal 250k pull-up resistor and A, B are pulled low through the 125k receiver input resistors.

If the LTC2879X is powered or depowered when configured for shutdown ($\overline{\text{RE}} = 0\text{V}$ and/or $\text{DE} = V_{\text{CC}}$) then RO, A and B will remain in the undriven state, without glitching high or low during the supply transition. This allows the powering and depowering of the LTC2879X when connected onto a live network without disturbing the lines.

±60V FAULT PROTECTION

TIA/EIA-485-A specifies that ground shifts between two devices on a network can be as large as -7V to $+12\text{V}$ during operation. Most RS485 transceivers cannot safely tolerate voltages on their interface pins that are much higher than this range. However, industrial installations may encounter voltages much greater than this.

The LTC2879X A and B pins can be safely shorted to voltages as high as $\pm 60\text{V}$. This extreme level of fault protection is achieved by using a high voltage BiCMOS integrated circuit technology. The naturally high breakdown voltage of this technology provides protection in powered off and high impedance conditions. Figure 13 further illustrates how the driver and receiver inputs tolerate large voltages above the supply and below ground

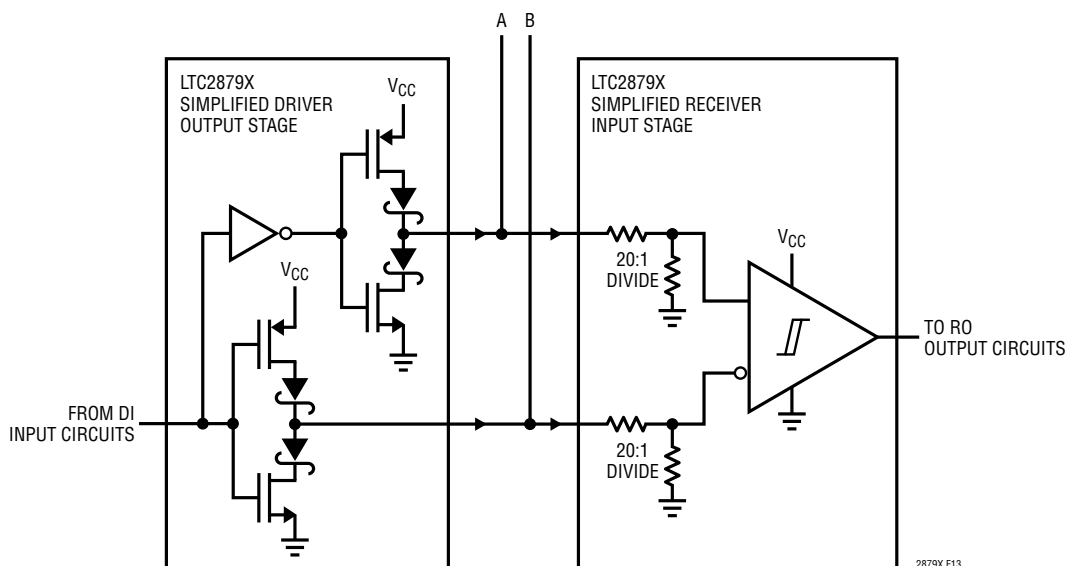

Figure 13. Internal Circuit Structure at A/B Pins that Tolerates Large Positive and Negative Voltages

APPLICATIONS INFORMATION

without excessive device currents. As shown, the driver outputs are reverse-diode protected from voltages back-driven above V_{CC} or below ground. The receiver inputs use resistive dividers that tolerate large positive and negative voltages. The LTC2879X is protected from $\pm 60V$ bus faults even with the loss of GND or V_{CC} .

ELECTRICAL OVERSTRESS PROTECTION

Equipment used in industrial environments is often exposed to extremely high levels of electrical overstress due to phenomena such as electrostatic discharges (ESD) from personnel or equipment, electrical fast transients (EFT) from switching high current inductive loads, and

even lightning surges. The LTC2879X has been designed to thrive in these adverse conditions.

ESD

Perhaps the most common exposure to electrical overstress is ESD, which results from the build-up of electrical charge on one object, and discharged onto another in close proximity. The LTC2879X features exceptionally robust ESD protection. The bus interface pins (A and B) are protected to $\pm 52kV$ human body model (HBM) with respect to GND when unpowered and $\pm 26kV$ with respect to GND or V_{CC} when powered, without latchup or damage, in any mode of operation. Every other pin on the device is protected to $\pm 15kV$ ESD (HBM) for all-around robustness.

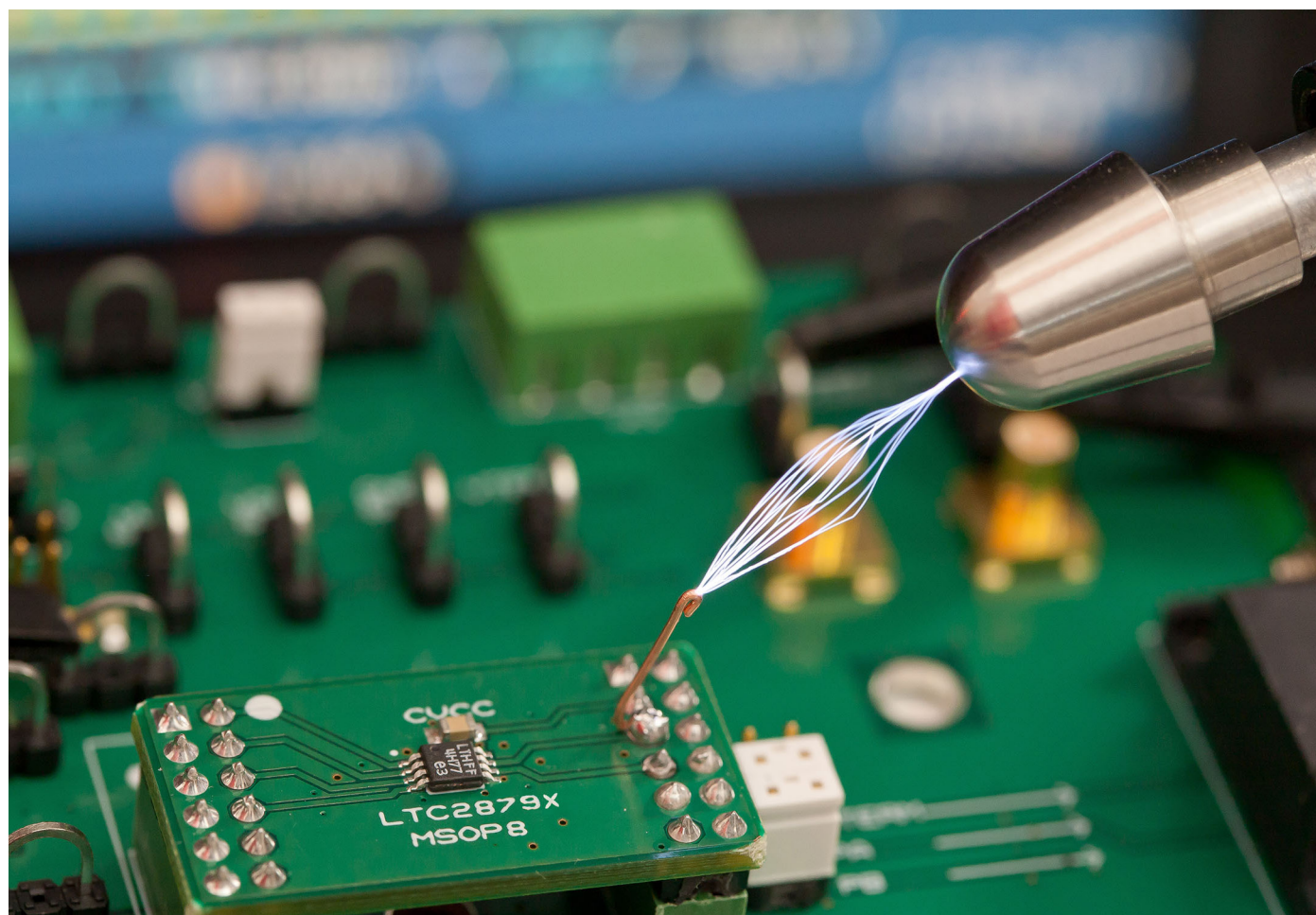

Figure 14. This Single Exposure Image Captures the Striking Robustness of an Unprotected LTC2879X Hit Repeatedly with 26kV ESD Discharges While Operating without Damage or Circuit Latchup

APPLICATIONS INFORMATION

Figure 14 shows an unprotected LTC2879X struck repeatedly with 26kV from an ESD gun using air discharge to illustrate the strike energy. The device continues to function normally after the strikes, without damage or cycling the power.

EFT

Electrical fast transients can result from arcing contacts in switches and relays, common when switching inductive loads. The IEC standard for EFT is IEC61000-4-4 and specifies a repetitive burst pattern lasting 60 seconds. The LTC2879X is robust to EFT events and passes the highest level recognized in the IEC standard: level 4, $\pm 2\text{kV}$ on the A and B pins, without any external protection.

PROFIBUS APPLICATIONS

The LTC2879X meets the requirements for PROFIBUS applications for all data rates up to 12Mbps over the full temperature range. Unlike some RS485 transceivers that claim PROFIBUS compliance but test only to RS485 standards, the LTC2879X is tested to the specifications for PROFIBUS-DP masters and PROFIBUS-DP slaves, fully compatible with IEC 61158-2, Type 3: medium attachment unit: asynchronous transmission, wire medium. These tests are performed using specific PROFIBUS loads to ensure compliance.

When using the LTC2879X in PROFIBUS applications, beware that the naming convention for PROFIBUS wires is opposite to convention commonly used for RS485. In standard installations, connect the LTC2879X A pin to the B wire (red) and the LTC2879X B pin to the A wire (green).

For more information on PROFIBUS applications, refer to the LTC2876/LTC2877 data sheet.

3.3V OPERATION

The LTC2879X can be used with a supply voltage as low as 3.0V in RS485 installations. Reducing the supply voltage reduces the driver output signal swing below what is specified in the RS485 standard but still produces signals much larger than the 200mV minimum signal swing required at the receiver input. A plot in the Typical Performance Characteristics section shows the driver output signal for 3.3V and 5V supply voltages.

3.3V-powered LTC2879X devices can be mixed with other RS485 transceivers running from 5V on the same network. There is no concern for the higher voltage of a 5V node overdriving the 3.3V node due to the overvoltage-tolerant design of the LTC2879X, as illustrated in Figure 13.

One advantage to using a lower supply voltage is reduced V_{CC} current draw. V_{CC} supply currents are roughly proportional to the applied supply voltage when the LTC2879X is driving loads. The Typical Performance Characteristics section shows the typical power supply currents versus transmission rates for 3.3V and 5V supplies.

PROFIBUS installations that use the LTC2879X with supply voltages less than 4.5V, may fall out of compliance to the PROFIBUS specification.

HIGH SPEED CONSIDERATIONS

A ground plane layout with a 0.1 μF bypass capacitor placed less than 7mm away from V_{CC} is recommended. The PC board traces connected to signal A and B should be symmetrical and as short as possible to maintain good differential signal integrity. To minimize capacitive effects, the differential signals should be separated by more than the width of a trace and should not be routed on top of each other if they are on different signal planes.

Care should be taken to route the outputs away from the sensitive inputs to reduce feedback effects that might cause noise, jitter, and even oscillations. For example, DI and RO should not be routed next to each other or next to A and B.

Logic inputs have a typical hysteresis of about 150mV to provide noise immunity. Fast edges on the outputs can cause glitches in the ground and power supplies which are exacerbated by capacitive loading. If a logic input is held near its threshold (typically $V_{CC}/2$), a noise glitch from a driver transition may exceed the hysteresis levels on the logic and data input pins, causing an unintended state change. This can be avoided by maintaining normal logic levels on the pins and by slewing inputs faster than 1V/ μs . Good supply decoupling and proper driver termination also reduces glitches caused by driver transitions.

PACKAGE DESCRIPTION

Please refer to <http://www.linear.com/product/LTC2879X#packaging> for the most recent package drawings.

MS8E Package 8-Lead Plastic MSOP, Exposed Die Pad (Reference LTC DWG # 05-08-1662 Rev K)

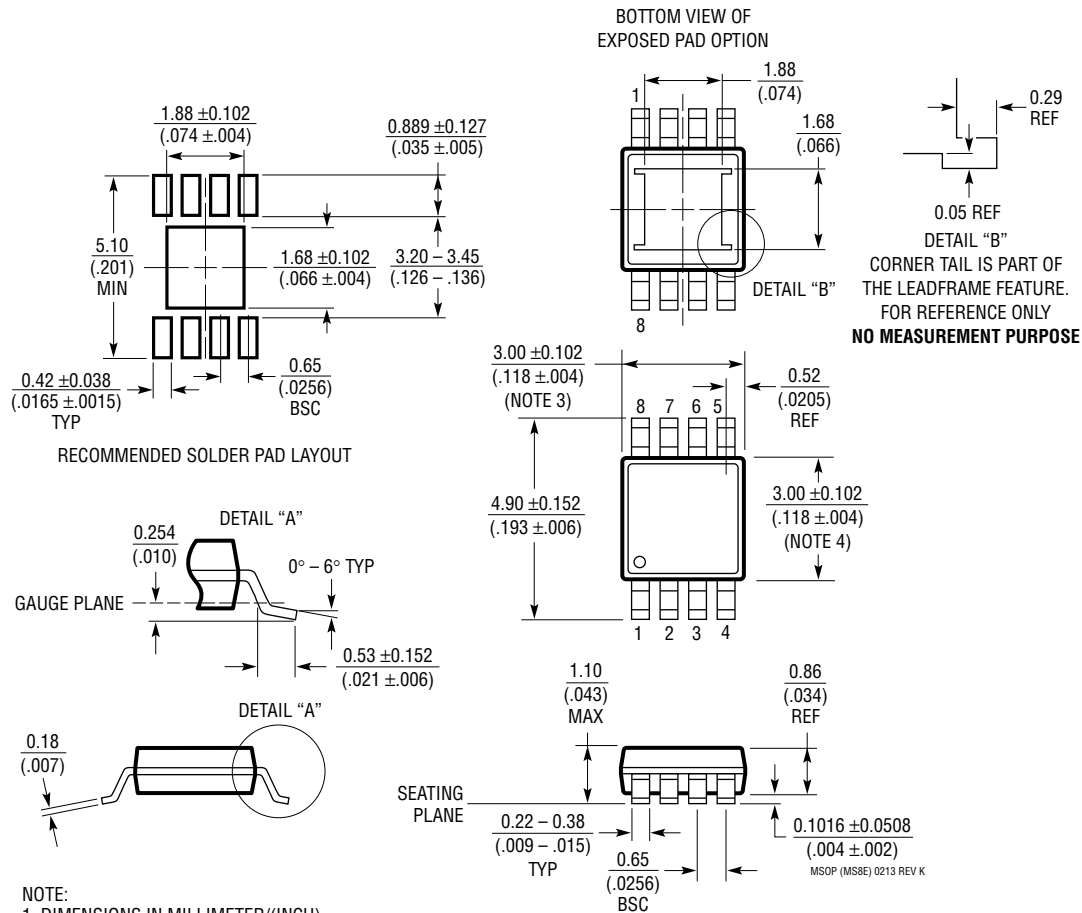

NOTE:

1. DIMENSIONS IN MILLIMETER/(INCH)
2. DRAWING NOT TO SCALE
3. DIMENSION DOES NOT INCLUDE MOLD FLASH, PROTRUSIONS OR GATE BURRS. MOLD FLASH, PROTRUSIONS OR GATE BURRS SHALL NOT EXCEED 0.152mm (.006") PER SIDE
4. DIMENSION DOES NOT INCLUDE INTERLEAD FLASH OR PROTRUSIONS. INTERLEAD FLASH OR PROTRUSIONS SHALL NOT EXCEED 0.152mm (.006") PER SIDE
5. LEAD COPLANARITY (BOTTOM OF LEADS AFTER FORMING) SHALL BE 0.102mm (.004") MAX
6. EXPOSED PAD DIMENSION DOES INCLUDE MOLD FLASH. MOLD FLASH ON E-PAD SHALL NOT EXCEED 0.254mm (.010") PER SIDE.

TYPICAL APPLICATION

Multi-Node Network and End Termination Using the LTC2879X and LTC2859

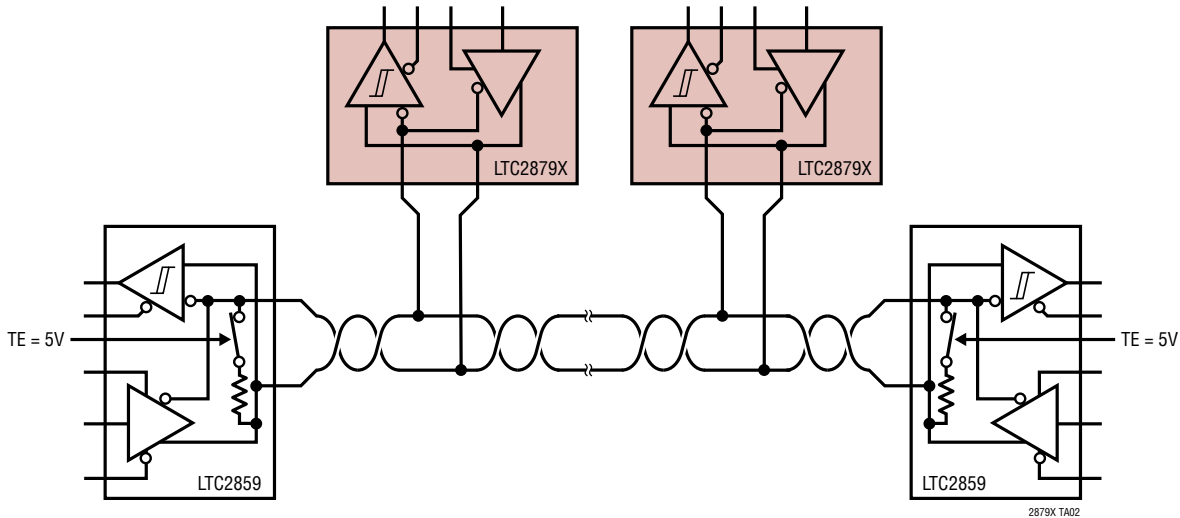

RELATED PARTS

PART NUMBER	DESCRIPTION	COMMENTS
LT8610AX	175°C, 42V, 3.5A Synchronous Step-Down Regulator	VIN: 3.7V to 42V, 16-Lead MSOP Package
LT1007X	200°C Low Noise Op Amp	Low Noise, High Speed Precision Operational Amplifier, 8-Lead TO-5 Metal Can Package
LTC1871X	175°C Wide Input Range Current Mode Boost, Flyback and SEPIC Controller	No Sense Resistor Required, 2.5V to 26V Wide Input Voltage Range
LT6203X	175°C Dual Ultralow Noise, Low Power Op Amp	100MHz, Rail-to-Rail Input and Output
LT1210X	175°C, 1.0A, 35MHz Current Feedback Amplifier	900V/μs Slew Rate, High Input Impedance, Low Power Shutdown Mode
LT580X/LT581X/LT582X	200°C Voltage Reference	Ultralow Drift, Curvature Corrected Reference, 3-Lead TO-52 Metal Can Package
LTC2876/LTC2877	±60V Rugged PROFIBUS RS485 Transceivers	±60V Tolerant, ±52kV ESD, 20Mbps