

## FEATURES

- Supervises 6 Power Supplies
- I<sup>2</sup>C Adjustable UV and OV Trip Points
- Guaranteed Threshold Accuracy: ±1%
- I<sup>2</sup>C/SMBus Interface
- Internal EEPROM
- 256 Programmable Thresholds per Channel
- Up to Three Range Settings per Channel
- Two General Purpose Inputs
- Three General Purpose Inputs/Outputs
- Programmable Output Delays
- Supply Voltage Range, 3.4V to 13.9V
- Supply Voltage Power Sharing from V1 to V4
- 16-Lead 5mm × 4mm DFN and SSOP Packages

## APPLICATIONS

- High Availability Computer Systems
- Network Servers
- Telecom Equipment
- Data Storage

LT, LT, LTC, LTM, Linear Technology and the Linear logo are registered trademarks of Linear Technology Corporation. All other trademarks are the property of their respective owners.

## DESCRIPTION

The **LTC<sup>®</sup>2933** is an EEPROM configurable voltage supervisor which can simultaneously monitor up to six power supply voltage inputs. Each voltage detector offers programmable over/undervoltage thresholds in various ranges and increments.

Two general purpose inputs (GPI) can be configured as programmable manual reset ( $\overline{\text{MR}}$ ), UV disable ( $\overline{\text{UVDIS}}$ ), margin ( $\overline{\text{MARG}}$ ) or auxiliary comparator ( $\overline{\text{AUXC}}$ ) inputs. Three general purpose pins (GPIO) can be configured for input or output operation. When configured as an input, a GPIO pin can be mapped to any other GPIO configured as output. The GPIO pins can also be configured as  $\overline{\text{ALERT}}$  or fault outputs. Faults can be configured with programmable delay-on-release times. Output type and polarity are also configurable.

Status and history registers log faults and can be polled via the I<sup>2</sup>C interface. A fault log snapshot is also backed up in internal EEPROM. All parameters are programmable via the I<sup>2</sup>C interface. Configuration EEPROM supports autonomous operation without additional software.

## TYPICAL APPLICATION

Precision Multiple Power Supply Supervisor

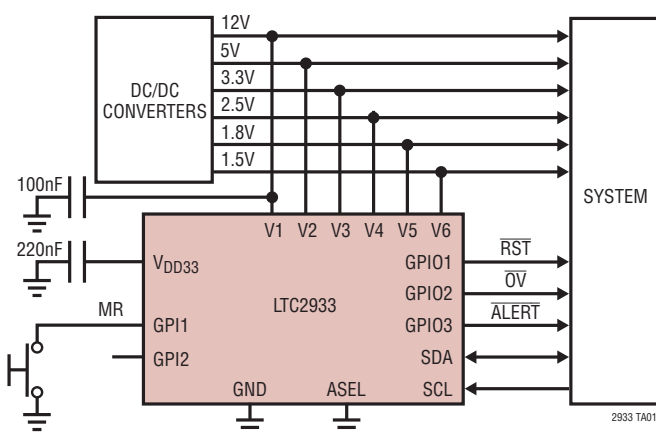

Normalized V1 to V6 Threshold vs Temperature

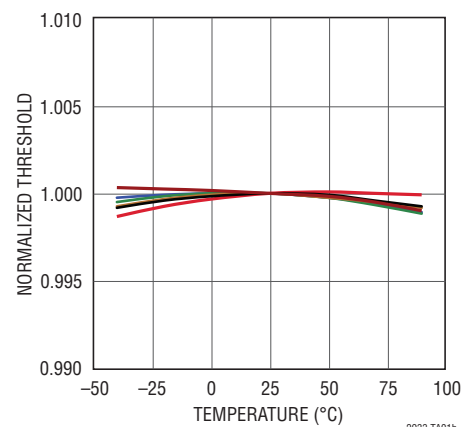

# LTC2933

## ABSOLUTE MAXIMUM RATINGS (Note 1)

### Supply Voltages:

V1 to GND ..... -0.3V to 14V  
 V2, V3, V4 to GND ..... -0.3V to 6V

### Input/Output Voltages:

SDA, SCL, GPI1, GPI2, V5, V6 ..... -0.3V to 6V  
 GPIO1, GPIO2, GPIO3 ..... -0.3V to 14V  
 V<sub>DD33</sub> ..... -0.3V to 3.6V  
 ASEL ..... -0.3V to V<sub>DD33</sub>

### Operating Temperature Range:

LTC2933C ..... 0°C to 70°C  
 LTC2933I ..... -40°C to 85°C

### Storage Temperature Range ..... -65°C to 125°C

### Lead Temperature Range (Soldering, 10 sec):

SSOP Packages ..... 300°C

## PIN CONFIGURATION

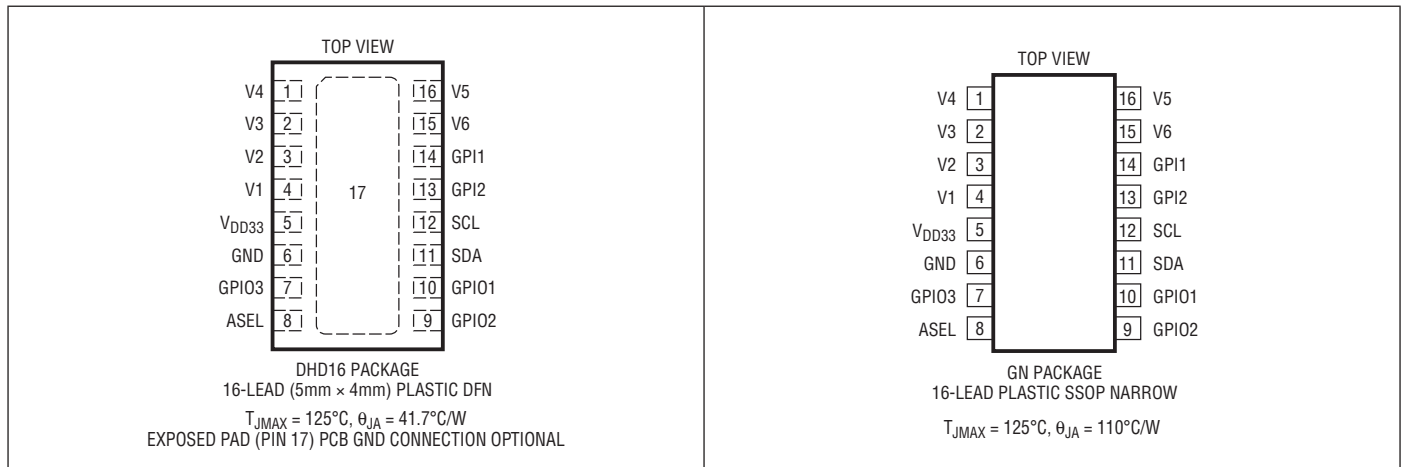

## ORDER INFORMATION

LEAD FREE FINISH	TAPE AND REEL	PART MARKING*	PACKAGE DESCRIPTION	TEMPERATURE RANGE
LTC2933CDHD#PBF	LTC2933CDHD#TRPBF	2933	16-Lead (5mm × 4mm) Plastic DFN	0°C to 70°C
LTC2933IDHD#PBF	LTC2933IDHD#TRPBF	2933	16-Lead (5mm × 4mm) Plastic DFN	-40°C to 85°C
LTC2933CGN#PBF	LTC2933CGN#TRPBF	2933	16-Lead Plastic SSOP	0°C to 70°C
LTC2933IGN#PBF	LTC2933IGN#TRPBF	2933	16-Lead Plastic SSOP	-40°C to 85°C

Consult LTC Marketing for parts specified with wider operating temperature ranges. \*The temperature grade is identified by a label on the shipping container.

For more information on lead free part marking, go to: <http://www.linear.com/leadfree/>

For more information on tape and reel specifications, go to: <http://www.linear.com/tapeandree/>

## ELECTRICAL CHARACTERISTICS

The ● denotes the specifications which apply over the full operating temperature range, otherwise specifications are at  $T_A = 25^\circ\text{C}$  and  $V_1 = 12\text{V}$ . (Notes 1, 2)

SYMBOL	PARAMETER	CONDITIONS	MIN	TYP	MAX	UNITS	
<b>Power Supply Characteristics</b>							
$V_n$	Supply Voltage Range	V1	●	3.4	13.9	V	
		V2 to V4	●	3.4	5.8	V	
$V_{DD33}$	$V_{DD33}$ Regulator Output Voltage	$I_{VDD33} = -1\text{mA}$	●	3.22	3.3	3.37	V
$I_{DD}$	$V_{DD33}$ Regulator Current Limit	$V_{DD33} = 0\text{V}$	●	-5.5		mA	
$I_{n\text{SUP}}$	V1 to V4 Supply Current	Highest Voltage Supplies Current	●		0.7	mA	
		Writing to EEPROM			1.5	mA	
<b>Voltage Supervisor Characteristics</b>							
$V_{1\text{RANGE}}$	V1 Monitoring Range	Medium Range	●	1	5.8	V	
		High Range	●	2.5	13.9	V	
$V_{2\text{RANGE}}$ to $V_{6\text{RANGE}}$	V2 to V6 Monitoring Range	Precision Range	●	0.2	1.2	V	
		Low Range	●	0.5	3	V	
		Medium Range	●	1	5.8	V	
$V_{1\text{STEP}}$	V1 Threshold Programming Step (LSB)	Medium Range		20		mV	
		High Range		50		mV	
$V_{2\text{STEP}}$ to $V_{6\text{STEP}}$	V2 to V6 Threshold Programming Step (LSB)	Precision Range		4		mV	
		Low Range		10		mV	
		Medium Range		20		mV	
$V_{1\text{ERR}}$	V1 Threshold Accuracy	Medium Range, $3\text{V} < V_1 < 5.8\text{V}$	●		$\pm 1.5$	%	
		Medium Range, $1\text{V} < V_1 < 3\text{V}$	●		$\pm 45$	mV	
		High Range, $7.5\text{V} < V_1 < 13.9\text{V}$	●		$\pm 1.5$	%	
		High Range, $2.5\text{V} < V_1 < 7.5\text{V}$	●		$\pm 112.5$	mV	
$V_{2\text{ERR}}$ to $V_{6\text{ERR}}$	V2 to V6 Threshold Accuracy	Precision Range, $0.6\text{V} < V_n < 1.2\text{V}$	●		$\pm 1$	%	
		Precision Range, $0.2\text{V} < V_n < 0.6\text{V}$	●		$\pm 6$	mV	
		Low Range, $1.5\text{V} < V_n < 3\text{V}$	●		$\pm 1$	%	
		Low Range, $0.5\text{V} < V_n < 1.5\text{V}$	●		$\pm 15$	mV	
		Medium Range, $3\text{V} < V_n < 5.8\text{V}$	●		$\pm 1$	%	
		Medium Range, $1\text{V} < V_n < 3\text{V}$	●		$\pm 30$	mV	
$R_{\text{IN}}$	$V_n$ Input Impedance	Low, Medium and High Range	●	200		k $\Omega$	
$I_{\text{IN}}$	$V_n$ Input Current	Precision Range, V2 to V4 = 1.2V	●		$\pm 2$	$\mu\text{A}$	
		Precision Range, V5 to V6 = 1.2V	●		$\pm 10$	nA	
$t_{\text{RT}}$	$V_n$ Comparator Response Time	2LSB of Overdrive	●	100		$\mu\text{s}$	
		20LSB of Overdrive		25	40	$\mu\text{s}$	
<b>Manual Reset Characteristics</b>							
$t_{\text{MRI}}$	Input Pulse Width	Active Low	●	5		$\mu\text{s}$	
$t_{\text{MRR}}$	Glitch Rejection			1		$\mu\text{s}$	
<b>GPIO Characteristics</b>							
$V_{\text{ITH}}$	Input Threshold Voltage		●	0.6	1	1.4	V
$I_{\text{LEAK}}$	Leakage Current	$V_{\text{GPI}} = 6\text{V}$	●		$\pm 2$	$\mu\text{A}$	
$I_{\text{PU}}$	Internal Pull-Up Current	$V_{\text{GPI}} = 2\text{V}$	●	-5	-15	-30	$\mu\text{A}$

## ELECTRICAL CHARACTERISTICS

The ● denotes the specifications which apply over the full operating temperature range, otherwise specifications are at  $T_A = 25^\circ\text{C}$  and  $V_1 = 12\text{V}$ . (Notes 1, 2)

SYMBOL	PARAMETER	CONDITIONS	MIN	TYP	MAX	UNITS
<b>Auxiliary Comparator Characteristics</b>						
$V_{ACIN}$	Input Threshold Voltage		● 0.49	0.5	0.51	V
$I_{ACIN}$	Input Current	Input Voltage = 0.5V	●		±20	nA
$t_{ACRT}$	Response Time	40mV Overdrive		9		μs
<b>GPIO Characteristics</b>						
$V_{OL}$	Output Low Voltage	$I_{SINK} = 3\text{mA}$	●		0.4	V
$V_{ITH}$	Input Threshold Voltage		● 0.6	1	1.4	V
$I_{LEAK}$	Leakage Current	$V_{GPIO} = 13.9\text{V}$	●		±2	μA
$I_{PU}$	Internal Pull-Up Current	$V_{GPIO} = 2\text{V}$	● -5	-15	-30	μA
$t_{DRO}$	Programmable Output Delay-on-Release GPIO1_DELAY_ON_RELEASE, GPIO2_DELAY_ON_RELEASE and GPIO3_DELAY_ON_RELEASE	000b	●	0.001	0.050	ms
		001b	● 1.1	1.6	2.2	ms
		010b	● 4.5	6.4	8.7	ms
		011b	● 17	26	34	ms
		100b	● 35	51	69	ms
		101b	● 143	205	275	ms
		110b	● 286	410	550	ms
		111b	● 1140	1640	2200	ms
<b>EEPROM Characteristics</b>						
Retention	Retention		● 10			Years
Endurance	Endurance		● 10,000			Cycles
$t_{EEFS}$	Fault Storage Time	Backup Fault Storage Operation		10		ms
$t_{EEPR}$	Programming Time	I <sup>2</sup> C NACK's During STORE_USER Operation		100		ms
$t_{EERU}$	Restore Time	RESTORE_USER Command		1		ms
<b>Digital Inputs SCL, SDA</b>						
$V_{IH}$	High Level Input Voltage		● 2			V
$V_{IL}$	Low Level Input Voltage		●		0.8	V
$V_{HYST}$	Input Hysteresis (Note 4)			40		mV
$I_{LEAK}$	Input Leakage Current	SCL, SDA = GND to 5.5V	● -1		1	μA
<b>Digital Output SDA</b>						
$V_{OL}$	Digital Output Low Voltage	$I_{SINK} = 3\text{mA}$	●		0.4	V
<b>Digital Input ASEL</b>						
$V_{IH}$	Input High Threshold Voltage		●		$V_{DD33} - 0.4$	V
$V_{IL}$	Input Low Threshold Voltage		● 0.4			V
$I_{IH,IL}$	High, Low Input Current	ASEL = 0, $V_{DD33}$	● -20		20	μA
$I_{FLOAT}$	Hi-Z Input Current	$0.5\text{V} < \text{ASEL} < V_{DD33} - 0.5\text{V}$	● -10		10	μA
<b>Serial Bus Timing Characteristics (Note 3)</b>						
$f_{SCL}$	Serial Clock Frequency		● 10		400	kHz
$t_{LOW}$	Serial Clock LOW Period		● 1.3			μs
$t_{HIGH}$	Serial Clock HIGH Period		● 0.6			μs
$t_{BUF}$	Bus Free Time Between STOP and START		● 1.3			μs
$t_{HD:STA}$	START Condition Hold Time		● 600			ns

## ELECTRICAL CHARACTERISTICS

The ● denotes the specifications which apply over the full operating temperature range, otherwise specifications are at  $T_A = 25^\circ\text{C}$  and  $V_1 = 12\text{V}$ . (Notes 1, 2)

SYMBOL	PARAMETER	CONDITIONS	MIN	TYP	MAX	UNITS
$t_{\text{SU:STA}}$	START Condition Setup Time	●	600			ns
$t_{\text{SU:STO}}$	STOP Condition Setup Time	●	600			ns
$t_{\text{HD:DAT}}$	Data Hold Time	LTC2933 Receiving Data	●	0		ns
		LTC2933 Transmitting Data	●	300	900	ns
$t_{\text{SU:DAT}}$	Data Setup Time	●	100			ns
$t_{\text{SP}}$	Pulse Width of Spike Suppressed			100		ns
$t_{\text{TIMEOUT\_BUS}}$	Time Allowed to Complete Any Command After Which Time SDA Will Be Released and Command Terminated			32		ms

**Note 1:** Stresses beyond those listed under Absolute Maximum Ratings may cause permanent damage to the device. Exposure to any Absolute Maximum Rating condition for extended periods may affect device reliability and lifetime.

**Note 2:** All currents into device pins are positive; all currents out of device pins are negative. All voltages are referenced to ground unless otherwise specified.

**Note 3:** Maximum capacitive load,  $C_B$ , for SCL and SDA is 400pF. Data and clock rise time ( $t_r$ ) and fall time ( $t_f$ ) are:

$$(20 + 0.1 \cdot C_B)(\text{ns}) < t_r < 300\text{ns}, \text{ and}$$

$$(20 + 0.1 \cdot C_B)(\text{ns}) < t_f < 300\text{ns}$$

$C_B$  = capacitance of one bus line in pF. SCL and SDA external pull-up voltage,  $V_{IO}$ , is  $3\text{V} < V_{IO} < 5.5\text{V}$ .

**Note 4:** Guaranteed by design, not directly tested.

## TIMING DIAGRAMS

### V<sub>n</sub> Supervisor Timing

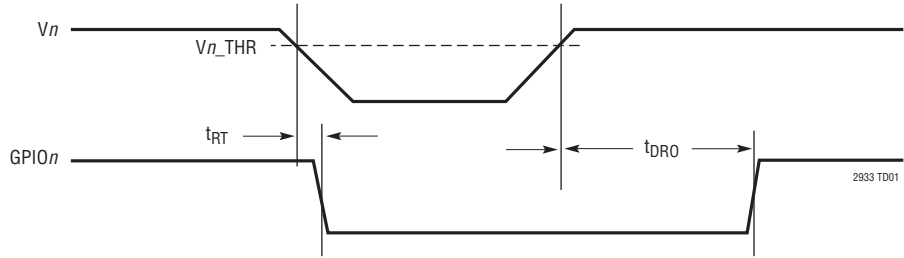

### I<sup>2</sup>C Timing

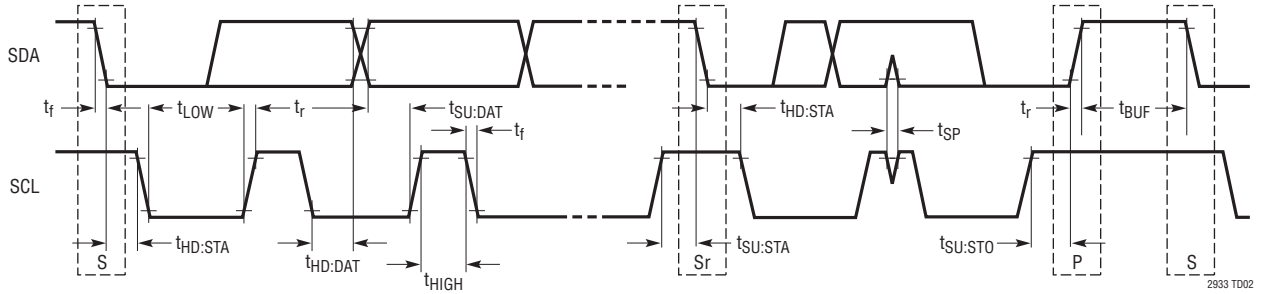

# TYPICAL PERFORMANCE CHARACTERISTICS

**V1 to V4 Supply Current vs Supply Voltage**

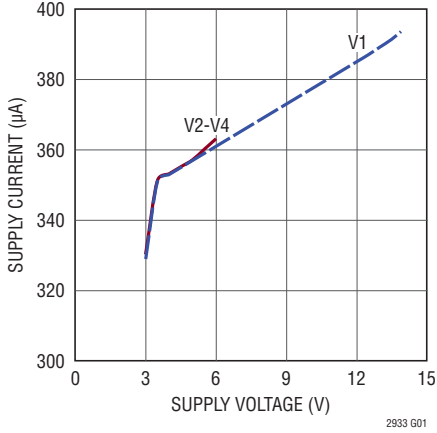

**V<sub>DD33</sub> vs Supply Voltage**

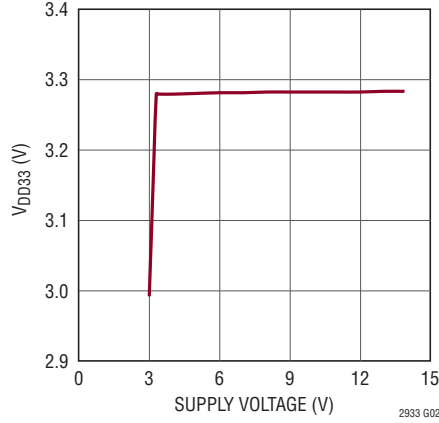

**V<sub>DD33</sub> vs Temperature**

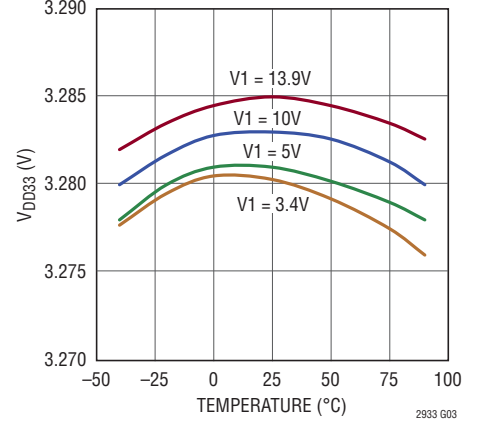

**V1 Comp Response Time vs Overdrive**

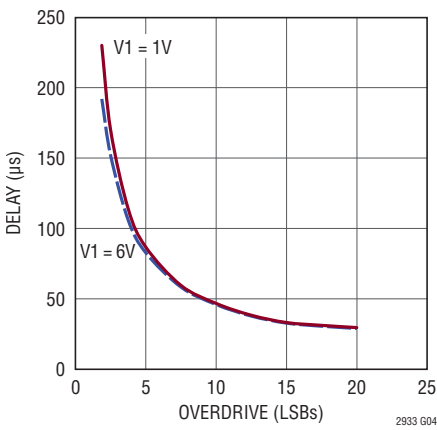

**V2 to V6 Comp Response Time vs Overdrive**

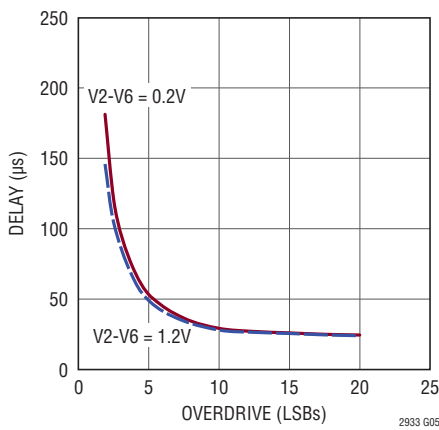

**Aux Comp Response Time vs Overdrive**

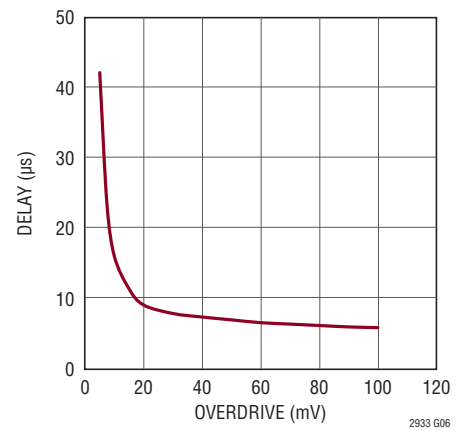

**GPIO Pins During Power-Up**

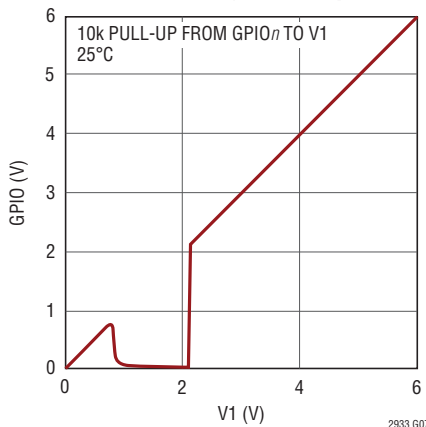

**Normalized GPIO Delay vs Temperature**

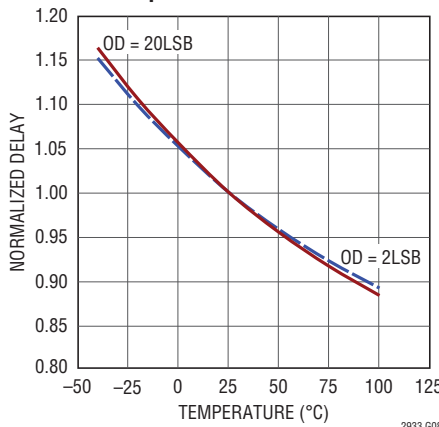

**GPIO Voltage vs Output Sink Current**

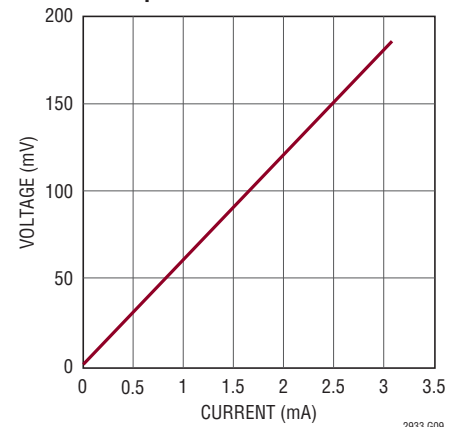

## PIN FUNCTIONS

**ASEL:** Ternary I<sup>2</sup>C Bus Address Select. Can be connected to ground, V<sub>DD33</sub>, or left unconnected to select one of three addresses.

**Exposed Pad (DFN Package Only):** Ground. The exposed pad may be left open or connected to device ground.

**GND:** Ground.

**GPI01, GPI02, GPI03:** General Purpose Input/Output. Each GPIO is configurable as either input, open-drain output, or weak pull-up output. Output polarity is programmable. When configured as outputs, these pins respond to selectable UV conditions, OV conditions,  $\overline{\text{MR}}$ , auxiliary comparator output, or other input-configured GPIO $n$  after programmable delay-on-release. These pins can also be configured as  $\overline{\text{ALERT}}$  per SMBus standard. When configured as inputs, each pin can be mapped to any other output. These pins have an optional 15 $\mu$ A pull-up to V<sub>DD33</sub>. Unused GPIO pins should be tied to V<sub>DD33</sub> or have their pull-up enabled.

**GPI1, GPI2:** General Purpose Inputs. Configurable as one of four possibilities (no duplication):

- Manual reset ( $\overline{\text{MR}}$ ) input, active low, 15 $\mu$ A pull-up to V<sub>DD33</sub>
- UV disable ( $\overline{\text{UVDIS}}$ ), active low, 15 $\mu$ A pull-up to V<sub>DD33</sub>. Outputs ignore UV faults.
- Margin ( $\overline{\text{MARG}}$ ), active low, 15 $\mu$ A pull-up to V<sub>DD33</sub>. Outputs ignore both UV and OV faults.
- Hi-Z Auxiliary Comparator (AUXC) Input. Programmable Polarity.

**SCL:** I<sup>2</sup>C Serial Clock (400kHz maximum). Needs external pull-up resistor.

**SDA:** I<sup>2</sup>C Serial Data. Needs external pull-up resistor.

**V1:** High Voltage Supervisor Input. Programmable thresholds, from 1V to 5.8V in 20mV increments (medium range) or from 2.5V to 13.9V in 50mV increments (high range). Bypass this pin to ground with a 0.1 $\mu$ F (or greater) capacitor and apply 3.4V minimum through a low impedance, if used to power the part. The highest voltage on V1 to V4 is automatically selected as supply voltage. If unused, tie to ground. See the Applications Information section for information on unused channels.

**V2 to V4:** Low Voltage Supervisor Input. Programmable thresholds from 0.2V to 1.2V in 4mV increments (precision range), from 0.5V to 3V in 10mV increments (low range) or from 1V to 5.8V in 20mV increments (medium range). Bypass this pin to ground with a 0.1 $\mu$ F (or greater) capacitor and apply 3.4V minimum through a low impedance, if used to power the part. The highest voltage on V1 to V4 is automatically selected as supply voltage. If unused, tie to ground. See the Applications Information section for information on unused channels.

**V5 to V6:** Low Voltage Supervisor Input. Programmable thresholds from 0.2V to 1.2V in 4mV increments (precision range), from 0.5V to 3V in 10mV increments (low range) or from 1V to 5.8V in 20mV increments (medium range). If unused, tie to ground. See the Applications Information section for information on unused channels.

**V<sub>DD33</sub>:** 3.3V Internal Regulator Output. A 220nF capacitor to ground is required.

PIN NAME	PIN TYPE	PIN (DFN)	PIN (SSOP)
V4	In	1	1
V3	In	2	2
V2	In	3	3
V1	In	4	4
V <sub>DD33</sub>	Out	5	5
GND	Ground	6	6
GPI03	In/Out	7	7
ASEL	In	8	8
GPI02	In/Out	9	9
GPI01	In/Out	10	10
SDA	In/Out	11	11
SCL	In	12	12
GPI2	In	13	13
GPI1	In	14	14
V6	In	15	15
V5	In	16	16
Exposed Pad		17	N/A



# BLOCK DIAGRAM

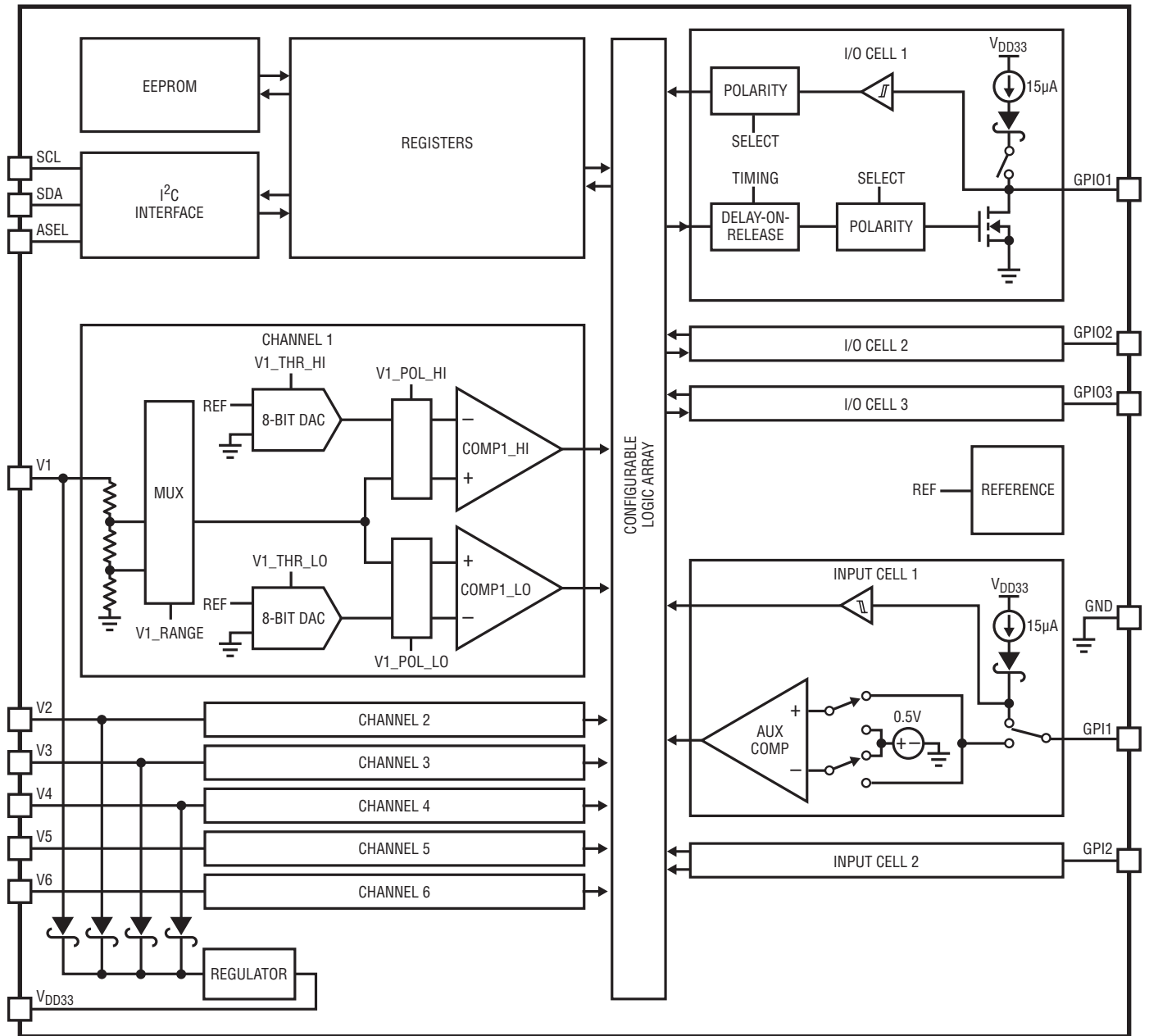

2933 BD

## OPERATION

The LTC2933 can perform the following operations:

- Accept I<sup>2</sup>C bus programming commands.
- Simultaneously monitor up to six inputs with respect to programmed fault limits.
- Configure and monitor for OV/UV faults using two independent comparators per channel.
- Manual reset.
- Configure two general purpose inputs as manual reset ( $\overline{\text{MR}}$ ), undervoltage disable ( $\overline{\text{UVDIS}}$ ), margin ( $\overline{\text{MARG}}$ ) or auxiliary comparator (AUXC) inputs.
- Configure three general purpose inputs/outputs (GPIO $n$ ) to output faults, inputs from GPIO $n$  or from other GPIO $n$ .
- Independently select each general purpose output polarity and type (open-drain or weak pull-up).
- Independently select each general purpose output response delay-on-release (with respect to the moment its condition is internally cleared).
- Generate interrupt ( $\overline{\text{ALERT}}$ ) signals in response to any voltage faults, as well as the logic state of the inputs.
- Store register contents to EEPROM.
- Store voltage and timing fault history to EEPROM.
- Restore EEPROM contents into the operating memory, by I<sup>2</sup>C command and at power-up.
- Report voltage fault status and history.
- Software write-protect the operating memory.

### Threshold Accuracy

The LTC2933  $\pm 1\%$  threshold accuracy specification improves the reliability of the system over supervisors with wider threshold tolerances. A less accurate voltage supervisor increases the required system voltage margin. This in turn increases the probability of system malfunction.

Consider a  $5\text{V} \pm 10\%$  supply: it may vary between 4.5V and 5.5V and the circuitry powered by it must operate reliably within this band. An ideal, perfectly accurate supervisor would generate a reset at exactly 4.5V. The LTC2933 threshold varies  $\pm 1\%$  around the nominal threshold voltage, in the medium range, if the selected value is greater than 3V. The reset threshold band and the power supply tolerance bands should not overlap, in order to prevent false alarms when the power supply actually meets its specified tolerance band (see Figure 1).

A  $\pm 10\%$  threshold is usually set to 11% below the nominal input voltage, or 4.45V in this example. The threshold is guaranteed to be within the 4.4V to 4.5V band over temperature. To prevent malfunction, the powered system must operate reliably down to 4.4V.

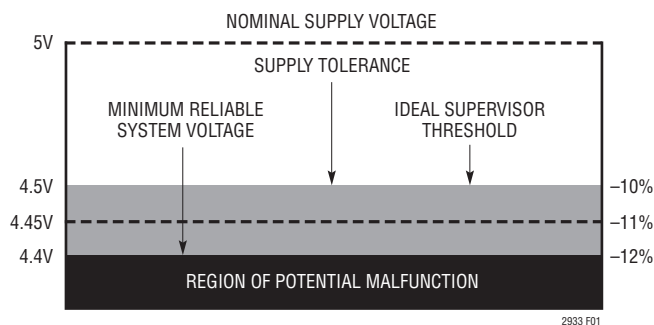

Figure 1. 1% Threshold Accuracy Improves System Reliability

## OPERATION

### I<sup>2</sup>C Serial Digital Interface

The LTC2933 communicates with a host (master) using the I<sup>2</sup>C serial bus interface. The Timing Diagram shows the timing relationship of the signals on the bus. The two bus lines, SDA and SCL, must be HIGH when the bus is not in use. External pull-up resistors or current sources are required on these lines.

The LTC2933 is a transmit/receive slave-only device. The master device must initiate data transfer on the bus by

generating SCL to allow the transfer. In the event of an OV/UV fault, the LTC2933 can be configured to assert the  $\overline{\text{ALERT}}$  output low in order to notify the host.

### Slave Address

The LTC2933 can respond to one of three addresses. By connecting the address ASEL input to V<sub>DD33</sub>, GND, or by floating it, the slave address is determined as shown in the following table. The LTC2933 always responds to special addresses.

LTC2933 Slave Address Table

ASEL	0	HI-Z	1
7-Bit Address	0x1C	0x1D	0x1E
8-Bit Address	0x38	0x3A	0x3C

LTC2933 Special Slave Addresses

7-Bit Address	8-Bit Address	Description
0x0C	0x19	Alert Response Address. Independent of the ASEL pin.
0x1B	0x36	Global address to which all LTC2933's will respond. Independent of the ASEL pin.

### Communication Protocols

- S START CONDITION
- Sr REPEATED START CONDITION
- Rd READ (BIT VALUE OF 1)
- Wr WRITE (BIT VALUE OF 0)
- A ACKNOWLEDGE (THIS BIT POSITION MAY BE 0 FOR AN ACK OR 1 FOR A NACK)
- P STOP CONDITION
- MASTER TO SLAVE
- SLAVE TO MASTER

### Send Byte Format

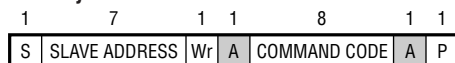

### Write Word Format

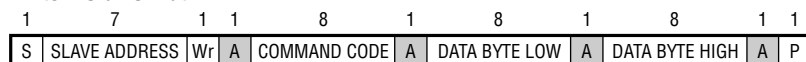

### Read Word Format

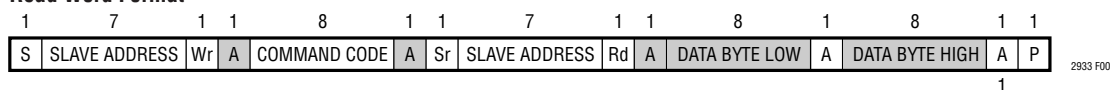

## OPERATION

### Register Command Set

COMMAND FUNCTION	DESCRIPTION	R/W/S (See Note)	DATA LENGTH (BITS)	COMMAND BYTE	DEFAULT VALUE
WRITE_PROTECT	Contains lock key code and write lock.	R/W	16	0x00	0xAAA8
GPI_CONFIG	Configure GPI2 and GPI1 assignment, GPIO $n$ mapping and $\overline{MR}$ internal response.	R/W	16	0x01	0x1000
GPIO1_CONFIG	Configure GPIO1 type, delay-on-release and mapping to GPIO2, GPIO3.	R/W	16	0x02	0x002B
GPIO2_3_CONFIG	Configure GPIO3 type, delay-on-release and mapping to GPIO1 and GPIO2. Configure GPIO2 type, delay-on-release and mapping to GPIO1 and GPIO3.	R/W	16	0x03	0x2B2B
V1_THR	Encode high and low voltage thresholds on channel V1.	R/W	16	0x04	0xDEA8
V2_THR	Encode high and low voltage thresholds on channel V2.	R/W	16	0x05	0xE9B1
V3_THR	Encode high and low voltage thresholds on channel V3.	R/W	16	0x06	0x8B65
V4_THR	Encode high and low voltage thresholds on channel V4.	R/W	16	0x07	0xE9B1
V5_THR	Encode high and low voltage thresholds on channel V5	R/W	16	0x08	0x9B73
V6_THR	Encode high and low voltage thresholds on channel V6.	R/W	16	0x09	0x7A58
V1_CONFIG	Encode comparator range, polarity and GPIO $n$ mapping.	R/W	16	0x0A	0x0089
V2_CONFIG	Encode comparator range, polarity and GPIO $n$ mapping.	R/W	16	0x0B	0x0089
V3_CONFIG	Encode comparator range, polarity and GPIO $n$ mapping.	R/W	16	0x0C	0x0089
V4_CONFIG	Encode comparator range, polarity and GPIO $n$ mapping.	R/W	16	0x0D	0x0189
V5_CONFIG	Encode comparator range, polarity and GPIO $n$ mapping.	R/W	16	0x0E	0x0189
V6_CONFIG	Encode comparator range, polarity and GPIO $n$ mapping.	R/W	16	0x0F	0x0189
HISTORY_WORD	Read the fault history. Read only.	R	16	0x11	NA
CLEAR_HISTORY	Clear volatile memory history register. Write only.	S	0	0x1B	NA
STORE_USER	Store volatile memory to EEPROM. Write only.	S	0	0x1C	NA
RESTORE_USER	Restore volatile memory from EEPROM. Write only.	S	0	0x1D	NA
BACKUP_WORD	Read the EEPROM backup of the first fault history. Read only.	R	16	0x1E	NA
STATUS_WORD	Read the fault status. Read only.	R	16	0x1F	NA

**Note:** R = read, W = write, S = send byte

## OPERATION

### DETAILED COMMAND REGISTER DESCRIPTIONS

#### WRITE\_PROTECT (Command Byte 0x00)

The WRITE\_PROTECT command provides the ability to prevent any write operations into the volatile memory, if WRITE\_LOCK = 1. KEY may be changed when WRITE\_LOCK = 0, or in the same command that sets WRITE\_LOCK = 1.

When locked, WRITE\_LOCK can only be written to 0 if KEY matches the existing value in memory. For effective protection against false writes, KEY should contain at least one bit set to 1.

Writes to supported commands are ignored when WRITE\_LOCK = 1. All commands may be read regardless of the WRITE\_LOCK bit setting.

#### WRITE\_PROTECT Data Contents

BIT(S)	SYMBOL	PURPOSE
b[15:2]	KEY	Must match against programmed combination in order to deactivate write lock. Factory default 10_1010_1010_1010b (0x2AAA).
b[1]	Reserved	Ignore
b[0]	WRITE_LOCK	0: Unlocked. Writes to volatile memory are permitted. 1: Locked. Writing to volatile memory is not permitted. To unlock, set WRITE_LOCK = 0 with the appropriate key. Factory default 0.

## OPERATION

### GPI\_CONFIG (Command Byte 0x01)

The GPI\_CONFIG command configures internal response to a manual reset, sets each GPI function, and optionally maps GPI pins configured as Manual Reset ( $\overline{MR}$ ) or Auxiliary Comparator (AUXC) to one or more GPIO pins.

#### GPI\_CONFIG Data Contents

BIT(S)	SYMBOL	OPERATION
b[15]	Reserved	Ignore
b[14]	GPI2_MR_RESPONSE	Effective only if the input GPI2 is $\overline{MR}$ configured. 0: Disable CLEAR_HISTORY response. 1: Enable CLEAR_HISTORY response on falling edge of GPI2. Factory default 0.
b[13:11]	GPI2_CONFIG	000b: Manual Reset ( $\overline{MR}$ ) active low, 15 $\mu$ A pull-up. 001b: Reserved. 010b: Margin ( $\overline{MARG}$ ) active low, 15 $\mu$ A pull-up. Overvoltage and undervoltage faults are inhibited. 011b: UV Disable ( $\overline{UVDIS}$ ) active low, 15 $\mu$ A pull-up. Undervoltage faults are inhibited. 100b: and 101b: Auxiliary Comparator (AUXC) positive input on GPI2. 110b: and 111b: Auxiliary Comparator (AUXC) negative input on GPI2. Factory default 010b.
b[10]	MAP_GPI2_TO_GPIO3	0: GPI2 input is not mapped to GPIO3. 1: GPI2 input is mapped to GPIO3 if configured as $\overline{MR}$ or AUXC. Factory default 0.
b[9]	MAP_GPI2_TO_GPIO2	0: GPI2 input is not mapped to GPIO2. 1: GPI2 input is mapped to GPIO2 if configured as $\overline{MR}$ or AUXC. Factory default 0.
b[8]	MAP_GPI2_TO_GPIO1	0: GPI2 input is not mapped to GPIO1. 1: GPI2 input is mapped to GPIO1 if configured as $\overline{MR}$ or AUXC. Factory default 0.
b[7]	Reserved	Ignore
b[6]	GPI1_MR_RESPONSE	Effective only if the input GPI1 is $\overline{MR}$ configured. 0: Disable CLEAR_HISTORY response. 1: Enable CLEAR_HISTORY response on falling edge of GPI1. Factory default 0.
b[5:3]	GPI1_CONFIG	000b: Manual Reset ( $\overline{MR}$ ) active low, 15 $\mu$ A pull-up. 001b: Reserved. 010b: Margin ( $\overline{MARG}$ ) active low, 15 $\mu$ A pull-up. Overvoltage and undervoltage faults are inhibited. 011b: UV Disable ( $\overline{UVDIS}$ ) active low, 15 $\mu$ A pull-up. Undervoltage faults are inhibited. 100b: and 101b: Auxiliary Comparator (AUXC) positive input on GPI1. 110b: and 111b: Auxiliary Comparator (AUXC) negative input on GPI1. Factory default 000b.
b[2]	MAP_GPI1_TO_GPIO3	0: GPI1 input is not mapped to GPIO3. 1: GPI1 input is mapped to GPIO3 if configured as $\overline{MR}$ or AUXC. Factory default 0.
b[1]	MAP_GPI1_TO_GPIO2	0: GPI1 input is not mapped to GPIO2. 1: GPI1 input is mapped to GPIO2 if configured as $\overline{MR}$ or AUXC. Factory default 0.
b[0]	MAP_GPI1_TO_GPIO1	0: GPI1 input is not mapped to GPIO1. 1: GPI1 input is mapped to GPIO1 if configured as $\overline{MR}$ or AUXC. Factory default 0.

## OPERATION

### GPIO1\_CONFIG (Command Byte 0x02)

The GPIO1\_CONFIG command configures the GPIO1 mapping, delay-on-release time, output type, and polarity. If GPIO1\_TYPE\_AND\_POLARITY is configured as  $\overline{\text{ALERT}}$  (100b or 111b), the output is latched and cleared after the

LTC2933 acknowledges the alert response address (see SMBus protocol), HISTORY\_WORD is read, or a CLEAR\_HISTORY command is received. Only one GPIO $n$  pin should be configured as  $\overline{\text{ALERT}}$ . GPIO $n$ \_DELAY\_ON\_RELEASE does not apply to a GPIO $n$  pin configured as  $\overline{\text{ALERT}}$ .

#### GPIO1\_CONFIG Data Contents

BIT(S)	SYMBOL	OPERATION
b[15:8]	Reserved	Ignore
b[7]	MAP_GPIO1_TO_GPIO3	0: GPIO1 input is not mapped to GPIO3. 1: GPIO1 input is mapped to GPIO3. Factory default 0.
b[6]	MAP_GPIO1_TO_GPIO2	0: GPIO1 input is not mapped to GPIO2. 1: GPIO1 input is mapped to GPIO2. Factory default 0.
b[5:3]	GPIO1_DELAY_ON_RELEASE	000b: Delay selected is 0. 001b: Delay selected is 1.6ms. 010b: Delay selected is 6.4ms. 011b: Delay selected is 26ms. 100b: Delay selected is 51ms. 101b: Delay selected is 205ms. 110b: Delay selected is 410ms. 111b: Delay selected is 1.64s. Factory default 101b (205ms).
b[2:0]	GPIO1_TYPE_AND_POLARITY	000b: Active H input. 001b: Active L input. 010b: Active H open-drain output. 011b: Active L open-drain output. 100b: Active L open-drain $\overline{\text{ALERT}}$ output. 101b: Active H, weak pull-up output. 110b: Active L, weak pull-up output. 111b: Active L, weak pull-up $\overline{\text{ALERT}}$ output. Factory default 011b (Active L open-drain output).

## OPERATION

### GPIO2\_3\_CONFIG (Command Byte 0x03)

The GPIO2\_3\_CONFIG command configures GPIO2 and GPIO3 mapping, delay-on-release time, output type, and polarity. If GPIO2\_TYPE\_AND\_POLARITY is configured as  $\overline{\text{ALERT}}$  (100b or 111b), or GPIO3\_TYPE\_AND\_POLARITY is configured as  $\overline{\text{ALERT}}$  (100b or 111b), the output is latched,

and is cleared after the LTC2933 acknowledges the alert response address (see SMBus protocol), HISTORY\_WORD is read, or a CLEAR\_HISTORY command is received. Only one GPIO $n$  pin should be configured as  $\overline{\text{ALERT}}$ . GPIO $n$ \_DELAY\_ON\_RELEASE does not apply to a GPIO $n$  pin configured as  $\overline{\text{ALERT}}$ .

#### GPIO2\_3\_CONFIG Data Contents

BIT(S)	SYMBOL	OPERATION
b[15]	MAP_GPIO3_TO_GPIO2	0: GPIO3 is not mapped into GPIO2. 1: GPIO3 is mapped into GPIO2. Factory default 0.
b[14]	MAP_GPIO3_TO_GPIO1	0: GPIO3 is not mapped into GPIO1. 1: GPIO3 is mapped into GPIO1. Factory default 0.
b[13:11]	GPIO3_DELAY_ON_RELEASE	000b: Delay selected is 0. 001b: Delay selected is 1.6ms. 010b: Delay selected is 6.4ms. 011b: Delay selected is 26ms. 100b: Delay selected is 51ms. 101b: Delay selected is 205ms. 110b: Delay selected is 410ms. 111b: Delay selected is 1.64s. Factory default 101b (205ms).
b[10:8]	GPIO3_TYPE_AND_POLARITY	000b: Active H input. 001b: Active L input. 010b: Active H open-drain output. 011b: Active L open-drain output. 100b: Active L open-drain $\overline{\text{ALERT}}$ output. 101b: Active H, weak pull-up output. 110b: Active L, weak pull-up output. 111b: Active L, weak pull-up $\overline{\text{ALERT}}$ output. Factory default 011b (Active L open-drain output).
b[7]	MAP_GPIO2_TO_GPIO3	0: GPIO2 is not mapped into GPIO3. 1: GPIO2 is mapped into GPIO3. Factory default 0.
b[6]	MAP_GPIO2_TO_GPIO1	0: GPIO2 is not mapped into GPIO1. 1: GPIO2 is mapped into GPIO1. Factory default 0.
b[5:3]	GPIO2_DELAY_ON_RELEASE	000b: Delay selected is 0. 001b: Delay selected is 1.6ms. 010b: Delay selected is 6.4ms. 011b: Delay selected is 26ms. 100b: Delay selected is 51ms. 101b: Delay selected is 205ms. 110b: Delay selected is 410ms. 111b: Delay selected is 1.64s. Factory default 101b (205ms).
b[2:0]	GPIO2_TYPE_AND_POLARITY	000b: Active H input. 001b: Active L input. 010b: Active H open-drain output. 011b: Active L open-drain output. 100b: Active L open-drain $\overline{\text{ALERT}}$ output. 101b: Active H, weak pull-up output. 110b: Active L, weak pull-up output. 111b: Active L, weak pull-up $\overline{\text{ALERT}}$ output. Factory default 011b (Active L open-drain output).

2933f



## OPERATION

### V1\_THR (Command Byte 0x04), V2\_THR (0x05), V3\_THR (0x06), V4\_THR (0x07), V5\_THR (0x08), V6\_THR (0x09)

The  $V_n$ \_THR command allows the user to specify the high and low threshold monitoring voltages on each channel.

#### $V_n$ \_THR Data Contents Channels V1 to V6

BIT(S)	SYMBOL	OPERATION
b[15:8]	$V_n$ _THR_HI	The COMP $n$ _HI threshold. See the Applications Information section. Factory default settings of 0xDE, 0xE9, 0x8B, 0xE9, 0x9B, 0x7A correspond to 13.2V, 5.5V, 3.63V, 2.75V, 1.98V and 1.65V for channels V1 to V6, respectively.
b[7:0]	$V_n$ _THR_LO	The COMP $n$ _LO threshold. See the Applications Information section. Factory default settings of 0xA8, 0xB1, 0x65, 0xB1, 0x73, 0x58 correspond to 10.8V, 4.5V, 2.97V, 2.25V, 1.62V and 1.35V for channels V1 to V6, respectively.

### V1\_CONFIG (Command Byte 0x0A), V2\_CONFIG (0x0B), V3\_CONFIG (0x0C), V4\_CONFIG (0x0D), V5\_CONFIG (0x0E), V6\_CONFIG (0x0F)

The  $V_n$ \_CONFIG command programs V1 through V6 comparator range, polarity and mapping to GPIO.

#### $V_n$ \_CONFIG Data Contents Channel V1 to V6

BIT(S)	SYMBOL	OPERATION
b[15:10]	Reserved	Ignore
b[9:8]	$V_n$ _RANGE	Channel V1: 00b: High Range. 01b: Medium Range. 10b and 11b: Reserved. Factory default 00b.  Channels V2, V3, V4, V5 and V6: 00b: Medium Range. 01b: Low Range. 10b and 11b: Precision Range. Factory defaults are 00b on V2 to V3 and 01b on V4, V5 and V6.
b[7]	$V_n$ _POL_HI	Controls polarity of COMP $n$ _HI output reported by STATUS_WORD. See STATUS_WORD description for details. 0: Undervoltage. Indicates a fault when the input voltage is below $V_n$ _THR_HI. 1: Overvoltage. Indicates a fault when the input voltage is above $V_n$ _THR_HI. Factory default 1.
b[6]	$V_n$ _POL_LO	Controls polarity of COMP $n$ _LO output reported by STATUS_WORD. See STATUS_WORD description for details. 0: Undervoltage. Indicates a fault when the input voltage is below $V_n$ _THR_LO. 1: Overvoltage. Indicates a fault when the input voltage is above $V_n$ _THR_LO. Factory default 0.
b[5]	MAP_COMP $n$ _HI_TO_GPIO3	0: High comparator not mapped to GPIO3. 1: High comparator mapped to GPIO3. Factory default 0.
b[4]	MAP_COMP $n$ _HI_TO_GPIO2	0: High comparator not mapped to GPIO2. 1: High comparator mapped to GPIO2. Factory default 0.
b[3]	MAP_COMP $n$ _HI_TO_GPIO1	0: High comparator not mapped to GPIO1. 1: High comparator mapped to GPIO1. Factory default 1.

## OPERATION

### V<sub>n</sub>\_CONFIG Data Contents Channel V1 to V6

BIT(S)	SYMBOL	OPERATION
b[2]	MAP_COMP <sub>n</sub> _LO_TO_GPIO3	0: Low comparator not mapped to GPIO3. 1: Low comparator mapped to GPIO3. Factory default 0.
b[1]	MAP_COMP <sub>n</sub> _LO_TO_GPIO2	0: Low comparator not mapped to GPIO2. 1: Low comparator mapped to GPIO2. Factory default 0.
b[0]	MAP_COMP <sub>n</sub> _LO_TO_GPIO1	0: Low comparator not mapped to GPIO1. 1: Low comparator mapped to GPIO1. Factory default 1.

### HISTORY\_WORD (Command Byte 0x11)

The HISTORY\_WORD command returns two bytes of information with a summary of the faults since power was applied or HISTORY\_WORD was last cleared. HISTORY\_WORD is located in volatile memory and is automatically updated each time a fault occurs. HISTORY\_WORD is cleared using the CLEAR\_HISTORY command.

### CLEAR\_HISTORY (Command Byte 0x1B)

The CLEAR\_HISTORY command clears all the faults logged in the volatile HISTORY\_WORD register. A manual reset performs the same operation if GPI<sub>n</sub>\_MR\_RESPONSE = 1. Clearing HISTORY\_WORD does not affect the STATUS\_WORD content. Processing of the CLEAR\_HISTORY command typically takes less than 10ms, and the part will not acknowledge other I<sup>2</sup>C operations during that time.

### HISTORY\_WORD Data Contents

BIT(S)	SYMBOL	OPERATION
b[15:13]	Reserved	Ignore
b[12]	V6_HI_LATCHED_FAULT	1: Latched V6_HI_FAULT. 0: No fault.
b[11]	V6_LO_LATCHED_FAULT	1: Latched V6_LO_FAULT. 0: No fault.
b[10]	V5_HI_LATCHED_FAULT	1: Latched V5_HI_FAULT. 0: No fault.
b[9]	V5_LO_LATCHED_FAULT	1: Latched V5_LO_FAULT. 0: No fault.
b[8]	V4_HI_LATCHED_FAULT	1: Latched V4_HI_FAULT. 0: No fault.
b[7]	V4_LO_LATCHED_FAULT	1: Latched V4_LO_FAULT. 0: No fault.
b[6]	V3_HI_LATCHED_FAULT	1: Latched V3_HI_FAULT. 0: No fault.
b[5]	V3_LO_LATCHED_FAULT	1: Latched V3_LO_FAULT. 0: No fault.
b[4]	V2_HI_LATCHED_FAULT	1: Latched V2_HI_FAULT. 0: No fault.
b[3]	V2_LO_LATCHED_FAULT	1: Latched V2_LO_FAULT. 0: No fault.
b[2]	V1_HI_LATCHED_FAULT	1: Latched V1_HI_FAULT. 0: No fault.
b[1]	V1_LO_LATCHED_FAULT	1: Latched V1_LO_FAULT. 0: No fault.
b[0]	Reserved	Ignore

2933f

## OPERATION

### STORE\_USER (Command Byte 0x1C)

### RESTORE\_USER (Command Byte 0x1D)

The STORE\_USER and RESTORE\_USER commands access nonvolatile EEPROM memory. Once a command is stored in EEPROM using STORE\_USER, it will be restored to volatile operating memory with the RESTORE\_USER command or when the part powers up.

### BACKUP\_WORD (Command Byte 0x1E)

After the first fault occurs, HISTORY\_WORD is written to EEPROM for backup. Any subsequent BACKUP\_WORD write following a fault is inhibited until the CLEAR\_HISTORY command is issued. BACKUP\_WORD can be retrieved by sending a RESTORE\_USER command followed by a BACKUP\_WORD read. BACKUP\_WORD can be cleared in EEPROM by sending a CLEAR\_HISTORY command followed by a STORE\_USER command.

#### BACKUP\_WORD Data Contents

BIT(S)	SYMBOL	OPERATION
b[15:13]	Reserved	Ignore
b[12]	V6_HI_STORED_FAULT	1: Stored V6_HI_FAULT. 0: No fault.
b[11]	V6_LO_STORED_FAULT	1: Stored V6_LO_FAULT. 0: No fault.
b[10]	V5_HI_STORED_FAULT	1: Stored V5_HI_FAULT. 0: No fault.
b[9]	V5_LO_STORED_FAULT	1: Stored V5_LO_FAULT. 0: No fault.
b[8]	V4_HI_STORED_FAULT	1: Stored V4_HI_FAULT. 0: No fault.
b[7]	V4_LO_STORED_FAULT	1: Stored V4_LO_FAULT. 0: No fault.
b[6]	V3_HI_STORED_FAULT	1: Stored V3_HI_FAULT. 0: No fault.
b[5]	V3_LO_STORED_FAULT	1: Stored V3_LO_FAULT. 0: No fault.
b[4]	V2_HI_STORED_FAULT	1: Stored V2_HI_FAULT. 0: No fault.
b[3]	V2_LO_STORED_FAULT	1: Stored V2_LO_FAULT. 0: No fault.
b[2]	V1_HI_STORED_FAULT	1: Stored V1_HI_FAULT. 0: No fault.
b[1]	V1_LO_STORED_FAULT	1: Stored V1_LO_FAULT. 0: No fault.
b[0]	Reserved	Ignore

## OPERATION

### STATUS\_WORD (Command Byte 0x1F)

The STATUS\_WORD command returns two bytes of information with a summary of the current faults. The STATUS\_WORD content is read directly from the comparators and is a snapshot of the current state.

STATUS\_WORD faults may be disabled by setting GPI1\_CONFIG = 010b (MARG), GPI1\_CONFIG = 011b (UVDIS), GPI2\_CONFIG = 010b (MARG) or GPI2\_CONFIG = 011b (UVDIS) and asserting the appropriate GPI $n$  pin.

#### STATUS\_WORD Data Contents

BIT(S)	SYMBOL	OPERATION
b[15:13]	Reserved	Ignore
b[12]	V6_HI_FAULT	V6_POL_HI = 1 (default). 1: Fault (V6 greater than V6_THR_HI). 0: No fault (V6 less than V6_THR_HI).  V6_POL_HI = 0. 1: Fault (V6 less than V6_THR_HI). 0: No fault (V6 greater than V6_THR_HI).
b[11]	V6_LO_FAULT	V6_POL_LO = 1. 1: Fault (V6 greater than V6_THR_LO). 0: No fault (V6 less than V6_THR_LO).  V6_POL_LO = 0 (default). 1: Fault (V6 less than V6_THR_LO). 0: No fault (V6 greater than V6_THR_LO).
b[10]	V5_HI_FAULT	V5_POL_HI = 1 (default). 1: Fault (V5 greater than V5_THR_HI). 0: No fault (V5 less than V5_THR_HI).  V5_POL_HI = 0. 1: Fault (V5 less than V5_THR_HI). 0: No fault (V5 greater than V5_THR_HI).
b[9]	V5_LO_FAULT	V5_POL_LO = 1. 1: Fault (V5 greater than V5_THR_LO). 0: No fault (V5 less than V5_THR_LO).  V5_POL_LO = 0 (default). 1: Fault (V5 less than V5_THR_LO). 0: No fault (V5 greater than V5_THR_LO).
b[8]	V4_HI_FAULT	V4_POL_HI = 1 (default). 1: Fault (V4 greater than V4_THR_HI). 0: No fault (V4 less than V4_THR_HI).  V4_POL_HI = 0. 1: Fault (V4 less than V4_THR_HI). 0: No fault (V4 greater than V4_THR_HI).
b[7]	V4_LO_FAULT	V4_POL_LO = 1. 1: Fault (V4 greater than V4_THR_LO). 0: No fault (V4 less than V4_THR_LO).  V4_POL_LO = 0 (default). 1: Fault (V4 less than V4_THR_LO). 0: No fault (V4 greater than V4_THR_LO).
b[6]	V3_HI_FAULT	V3_POL_HI = 1 (default). 1: Fault (V3 greater than V3_THR_HI). 0: No fault (V3 less than V3_THR_HI).  V3_POL_HI = 0. 1: Fault (V3 less than V3_THR_HI). 0: No fault (V3 greater than V3_THR_HI).

## OPERATION

### STATUS\_WORD Data Contents

BIT(S)	SYMBOL	OPERATION
b[5]	V3_LO_FAULT	V3_POL_LO = 1. 1: Fault (V3 greater than V3_THR_LO). 0: No fault (V3 less than V3_THR_LO).  V3_POL_LO = 0 (default). 1: Fault (V3 less than V3_THR_LO). 0: No fault (V3 greater than V3_THR_LO).
b[4]	V2_HI_FAULT	V2_POL_HI = 1 (default). 1: Fault (V2 greater than V2_THR_HI). 0: No fault (V2 less than V2_THR_HI).  V2_POL_HI = 0. 1: Fault (V2 less than V2_THR_HI). 0: No fault (V2 greater than V2_THR_HI).
b[3]	V2_LO_FAULT	V2_POL_LO = 1. 1: Fault (V2 greater than V2_THR_LO). 0: No fault (V2 less than V2_THR_LO).  V2_POL_LO = 0 (default). 1: Fault (V2 less than V2_THR_LO). 0: No fault (V2 greater than V2_THR_LO).
b[2]	V1_HI_FAULT	V1_POL_HI = 1 (default). 1: Fault (V1 greater than V1_THR_HI). 0: No fault (V1 less than V1_THR_HI).  V1_POL_HI = 0. 1: Fault (V1 less than V1_THR_HI). 0: No fault (V1 greater than V1_THR_HI).
b[1]	V1_LO_FAULT	V1_POL_LO = 1. 1: Fault (V1 greater than V1_THR_LO). 0: No fault (V1 less than V1_THR_LO).  V1_POL_LO = 0 (default). 1: Fault (V1 less than V1_THR_LO). 0: No fault (V1 greater than V1_THR_LO).
b[0]	Reserved	Ignore

## APPLICATIONS INFORMATION

### Power Supply

The LTC2933 is powered from any one of the voltage monitoring inputs V1 through V4. A virtual diode-OR scheme selects the highest supply voltage. The LTC2933 generates a regulated 3.3V supply on the V<sub>DD33</sub> pin. A 100nF external capacitor from the highest supply voltage pin (V1 to V4) to GND is required in order to decouple any supply noise. A 220nF external capacitor from V<sub>DD33</sub> to GND is required to properly compensate the internal voltage regulator.

### Power-Up Condition

When power is applied such that at least one of the supply inputs V1 to V4 exceeds 3.4V, the part turns on and the EEPROM contents are loaded into the volatile operating memory. This operation typically takes less than 200μs.

### Power-Down Condition

If all of the supply inputs, V1 to V4, drop below 3.4V, the internal regulator will start to fall out of regulation. Once V<sub>DD33</sub> falls below the internal undervoltage lockout voltage, the GPIO outputs will pull low. See the Typical Performance Characteristics section.

### Voltage Threshold Programming

The V1 input has a high range that is based on a full scale of 2.25V to 15V. The 8-bit programming step size is 50mV. Some of these thresholds are outside of the 14V abs max voltage rating of the V1 input. On the high range, threshold accuracy below 2.5V and above 13.9V is not specified, but the thresholds are reachable.

The command byte for the voltage threshold can be calculated for the V1 high range with the following equation:

$$\text{Command Byte} = \text{ROUND} [20 \cdot (V_{\text{TH}} - 2.25)]$$

Inputs from V1 through V6 have a medium range that is based on a full scale of 0.9V to 6V. The 8-bit programming step size is 20mV. On the medium range, threshold accuracy below 1V and above 5.8V is not specified, but the thresholds are reachable.

The command byte for the voltage threshold can be calculated for the V1 to V6 medium range with the following equation:

$$\text{Command Byte} = \text{ROUND} [50 \cdot (V_{\text{TH}} - 0.9)]$$

Inputs from V2 through V6 have a low range that is based on a full scale of 0.45V to 3V. The 8-bit programming step size is 10mV. On the low range, threshold accuracy below 0.5V is not specified, but the thresholds are reachable.

The command byte for the voltage threshold can be calculated for the V2 to V6 low range with the following equation:

$$\text{Command Byte} = \text{ROUND} [100 \cdot (V_{\text{TH}} - 0.45)]$$

Inputs from V2 through V6 have a precision range that is based on a full scale of 0.18V to 1.2V. The 8-bit programming step size is 4mV. On the low range, threshold accuracy below 0.2V is not specified, but the thresholds are reachable.

The command byte for the voltage threshold can be calculated for the V2 to V6 precision range with the following equation:

$$\text{Command Byte} = \text{ROUND} [250 \cdot (V_{\text{TH}} - 0.18)]$$

Although all six channels have built-in glitch immunity, 100nF bypass capacitors on the V1 to V4 inputs are recommended because the largest V1 to V4 voltage is also the power supply for the device.

### Unused Channels

The user must connect all unused channel inputs to ground, program their configuration words (V<sub>n</sub>\_CONFIG) to 0x01C0, and program their thresholds (V<sub>n</sub>\_THR) to 0x0000 in order to avoid false faults.

### Auxiliary Comparators

Two additional auxiliary comparators can be connected to the general purpose inputs with either their inverting or their noninverting input while the other input internally connects to a 0.5V reference voltage. These low offset, low drift comparators can be used for additional monitoring purposes.

## APPLICATIONS INFORMATION

If the tap point on an external resistive divider from an external voltage,  $V_{TRIP}$ , to GND (see Figure 2) connects to the auxiliary comparator input, the trip voltage is:

$$V_{TRIP} = 0.5V \cdot \left(1 + \frac{R1}{R2}\right)$$

In a negative voltage application (also shown in Figure 2) the resistive divider is connected between the negative voltage being sensed and  $V_{DD33}$ , and the trip voltage is:

$$V_{TRIP} = 0.5V - 2.8V \cdot \left(\frac{R3}{R4}\right)$$

The minimum value for R4 is limited by the  $V_{DD33}$  current sourcing capability at:

$$\frac{3.3V - 0.5V}{1mA} = 2.8k\Omega$$

### Manual Reset

The  $\overline{MR}$  input is active low. If  $GPIO_n\_MR\_RESPONSE = 1$ , the  $HISTORY\_WORD$  register is cleared when  $\overline{MR}$  is pulled low. An internal  $15\mu A$  current source pulls  $\overline{MR}$  to  $V_{DD33}$ . The  $\overline{MR}$  input can also be mapped to a GPIO pin and combined with  $COMP_n\_HI$  and  $COMP_n\_LO$  faults to generate a system reset signal.

### UV Disable

When a GPIO pin is configured as  $\overline{UVDIS}$ , the input is active low. When  $\overline{UVDIS}$  is grounded, the LTC2933 does

not respond to UV type faults. This feature is useful when power cycling the monitored supply. An internal  $15\mu A$  current source pulls  $\overline{UVDIS}$  to  $V_{DD33}$ .

### Margin

When a GPIO pin is configured as  $\overline{MARG}$ , the input is active low. When  $\overline{MARG}$  is grounded, the LTC2933 does not respond to any OV or UV faults. This feature is useful when margining the monitored supply. An internal  $15\mu A$  current source pulls  $\overline{MARG}$  to  $V_{DD33}$ .

### Outputs

The GPIO $n$  outputs are open-drain, with an internal  $15\mu A$  current source pulling to  $V_{DD33}$  and can tolerate a pull-up voltage up to 14V.

All faults, GPIO $n$ , or other GPIO $n$  inputs mapped to a GPIO $n$  output are combined with a logical OR function.

The GPIO $n$  pins have programmable delay-on-release timing. The GPIO $n$  pin asserts its active state immediately and de-asserts after the delay-on-release time has elapsed. Any fault causing a GPIO $n$  pin to assert while its delay-on-release timer is active will reset the delay-on-release timer.

When a GPIO $n$  indicates an alert, the alert may be cleared using the standard SMBus Alert Response Address (ARA) protocol. Alerts may also be cleared by reading (or clearing)  $HISTORY\_WORD$  unless the condition causing the alert persists.

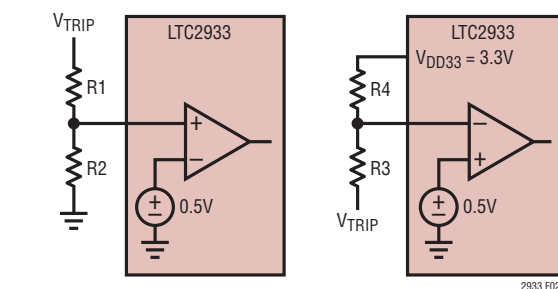

Figure 2. Auxiliary Comparator Usage

## APPLICATIONS INFORMATION

### Write Protect Features

When the WRITE\_PROTECT lock bit is set high, all I<sup>2</sup>C write word commands are ignored. This feature protects against accidental writing. The lock bit may still be written when the device is write protected if the provided value for KEY matches the value in memory.

### EEPROM

The user may save and restore configuration data to the operating memory registers at any time with STORE\_USER and RESTORE\_USER commands. Upon power-up, user-stored data is automatically loaded into the operating memory. The part ignores I<sup>2</sup>C commands while performing EEPROM transactions.

Nondestructive operation above T<sub>A</sub> = 85°C is possible, but may result in a slight degradation of the retention characteristics. The degradation in EEPROM retention for temperatures exceeding 85°C can be approximated by calculating the acceleration factor:

$$AF = e^{\left[ \left( \frac{E_a}{k} \right) \cdot \left( \frac{1}{T_{USE} + 273} - \frac{1}{T_{STRESS} + 273} \right) \right]}$$

Where:

AF = acceleration factor

E<sub>a</sub> = activation energy = 1.5eV

$$k = 8.625 \cdot 10^{-5} \text{ eV/}^\circ\text{K}$$

T<sub>USE</sub> = 85°C maximum specified operating temperature

T<sub>STRESS</sub> = actual temperature °C

Example: Calculate effect on retention when operating at a temperature of 95°C for 10 hours.

$$T_{STRESS} = 95^\circ\text{C}, T_{USE} = 85^\circ\text{C}, AF = 3.74$$

So, the overall retention of the EEPROM was degraded by 37.4 hours as a result of operation at a junction temperature of 95°C for 10 hours. Note that the effect of this overstress is negligible when compared to the overall EEPROM retention rating of 10 years (87,600 hours) at a temperature of 85°C.

### Negative Supply Power Monitor

Figure 3 illustrates how to configure the LTC2933 to monitor a negative supply rail. Assume the need to monitor the following supply rails: 1.5V within a ±5% system specification, 3.3V, 5V and -5V, within a ±10% system specification. In this example V1 and V2 are not used.

Channel V6 is set to medium range, channels V3 and V4 are set to high range, channel V5 is set to precision range, and channels V1 and V2 are not used.

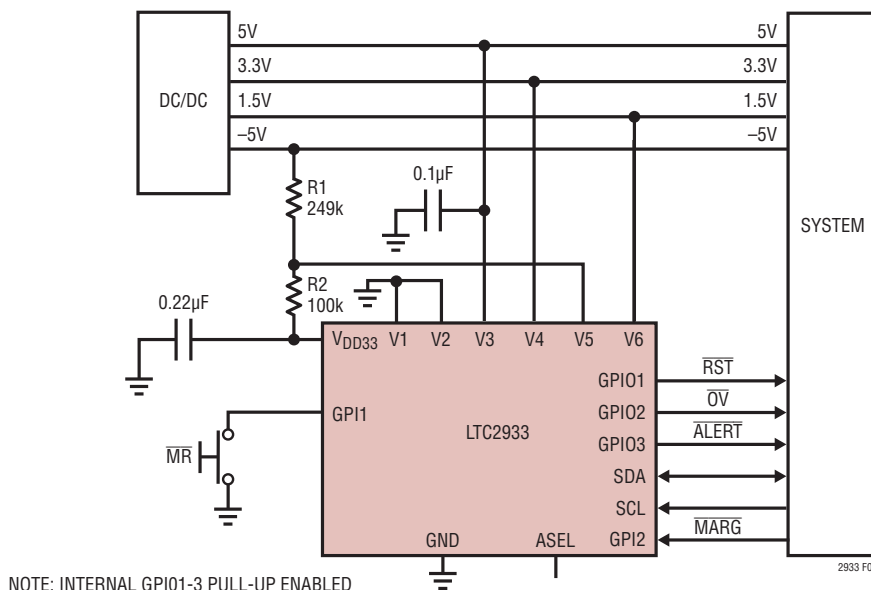

Figure 3. Negative Supply Power Monitor



## APPLICATIONS INFORMATION

Select low range for V6 (0.5V to 3V):

$$V6\_THR\_HI = \text{ROUND} [100 \cdot (1.5 \cdot 1.06 - 0.45)] = 114$$

$$V6\_THR\_LO = \text{ROUND} [100 \cdot (1.5 \cdot 0.94 - 0.45)] = 96$$

Select medium range for V3 and V4 (1V to 6V):

$$V3\_THR\_HI = \text{ROUND} [50 \cdot (3.3 \cdot 1.11 - 0.9)] = 139$$

$$V3\_THR\_LO = \text{ROUND} [50 \cdot (3.3 \cdot 0.89 - 0.9)] = 101$$

$$V4\_THR\_HI = \text{ROUND} [50 \cdot (5 \cdot 1.11 - 0.9)] = 233$$

$$V4\_THR\_LO = \text{ROUND} [50 \cdot (5 \cdot 0.89 - 0.9)] = 177$$

To monitor  $-5V$ , use an external resistive divider connected between  $V_{DD33}$  and the negative rail. The voltage at  $V_{DD33}$  is 3.3V. In order to minimize the error introduced by the leakage current into the V5 input pin, the output of this divider is targeted to lie within the precision voltage range (0.2V to 1.2V). The OV and UV thresholds for the  $-5V$  rail are calculated as follows:

$$V5_{MIN} = \frac{(3.3 \cdot R1) - 1.1 \cdot (5 \cdot R2)}{R1 + R2} > 0.2V$$

$$V5_{MAX} = \frac{(3.3 \cdot R1) - 0.9 \cdot (5 \cdot R2)}{R1 + R2} < 1.2V$$

$R1 = 249k \pm 0.1\%$  and  $R2 = 100k \pm 0.1\%$  satisfy the previous relationships. The programming codes can be calculated as shown in the following equations:

$$V5_{MIN} = \frac{(3.3 \cdot 0.98) \cdot (249 \cdot 0.999) - (1.1 \cdot 5) \cdot (100 \cdot 1.001)}{(249 \cdot 0.999) + (100 \cdot 1.001)} = 0.728V$$

$$V5_{MAX} = \frac{(3.3 \cdot 1.02) \cdot (249 \cdot 1.001) - (0.9 \cdot 5) \cdot (100 \cdot 0.999)}{(249 \cdot 1.001) + (100 \cdot 0.999)} = 1.115V$$

$$V5\_THR\_HI = \text{ROUND} [250 \cdot (0.728 \cdot 0.99 - 0.18)] = 135$$

$$V5\_THR\_LO = \text{ROUND} [250 \cdot (1.115 \cdot 1.01 - 0.18)] = 237$$

The normal polarities of the OV and UV comparators need to be swapped, since a drop of the negative supply below its specified absolute value increases  $V5_{MAX}$  beyond its encoded threshold. An increase of the negative supply above its specified absolute value decreases  $V5_{MIN}$  below its encoded threshold.

The GPIO $n$  outputs are programmed as  $\overline{RST}$  (active low system reset),  $\overline{OV}$  (active low system OV) and  $\overline{ALERT}$  (active low  $\overline{ALERT}$ , see SMBus specification). The UV comparators are mapped to GPIO1 and GPIO3. The OV comparators are mapped to GPIO2 and GPIO3. The GPI1 input is configured as  $\overline{MR}$  (manual reset) and is mapped to GPIO1. The GPI2 input is configured as  $\overline{MARG}$  (margin testing) allowing the system to disable OV and UV faults during margin testing.

## APPLICATIONS INFORMATION

### Eleven-Channel Supply Power Monitor

Figure 4 illustrates how to use multiple LTC2933 supervisors to monitor power rails. The system consists of two cascaded LTC2933 supervisors, both of them being powered from a common 12V dedicated rail connected to V1 to supervise ten supplies, plus the 12V rail.

The first supervisor monitors six rails and generates  $\overline{RST1}$  and  $\overline{OV1}$  signals if a rail faults. The  $\overline{MR}$  signal on GPI1 is also mapped into  $\overline{RST1}$ .

The second supervisor monitors the remaining five channels and generates  $\overline{RST}$  and  $\overline{OV}$  signals in re-

sponse to any faults. The GPI1 input is connected to the first supervisor  $\overline{RST1}$  output and is mapped to the second supervisor GPIO1 pin to generate the system  $\overline{RST}$  signal. The GPI2 input is connected to the first supervisor  $\overline{OV1}$  output and is mapped to the second supervisor GPIO2 pin to generate the system  $\overline{OV}$  signal. Thus, if any of the supervised rails faults or if there is a valid  $\overline{MR}$  signal, an appropriate global  $\overline{RST}$  or  $\overline{OV}$  is generated.

Both GPIO3 outputs of the LTC2933 supervisors are wired together and configured as  $\overline{ALERT}$  signals, per the SMBus protocol.

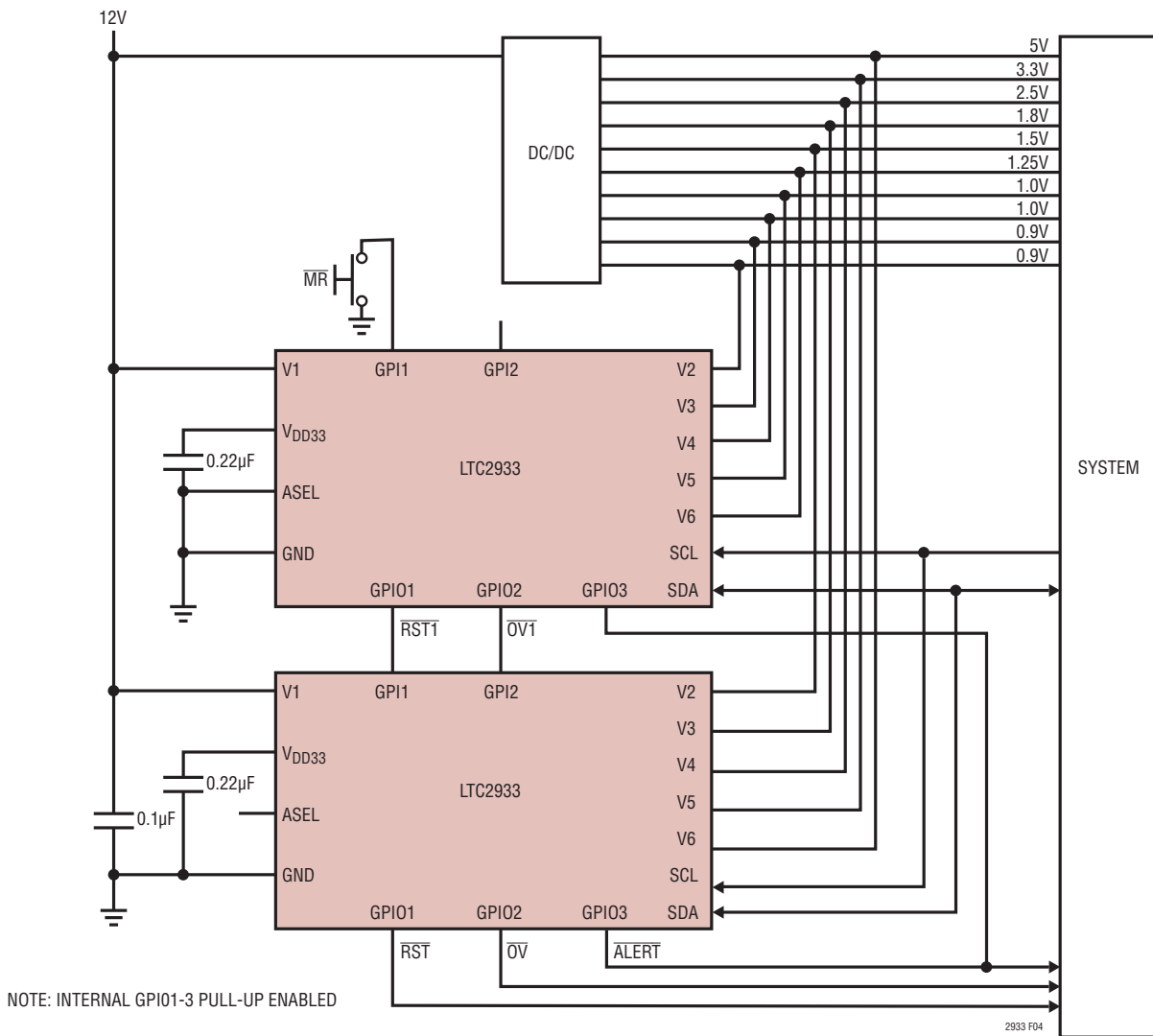

Figure 4. 11-Channel Supply Power Monitor

## TYPICAL APPLICATIONS

### Two-Channel Voltage Monitoring with EEPROM Fault Storage Power Backup

Figure 5 in the Typical Applications section illustrates an EEPROM fault storage power backup circuit. The LTC2933 is supplied by the 12V rail, which is also monitored on V1. The other monitored rail, 1.8V on V3, is too low to provide adequate supply voltage, in case the 12V line collapses to ground. In case such a fault occurs, the LTC2933 still needs adequate power for EEPROM backup fault storage, which takes less than 10ms. This is provided by the 22 $\mu$ F capacitor connected between the V2 pin and ground, which is charged from the 12V rail through R1. Since the V2 voltage may not exceed 6V, a 4.7V voltage-limiting Zener diode connected between V2 and ground is necessary. In this example, V4 through V6 are not used.

The minimum value of the charge-storage capacitor is calculated as:

$$C_{\text{MIN}} = \frac{I_{2\text{SUP(MAX)}} \cdot t_{\text{EEFS}}}{V2 - V2_{\text{MIN}}}$$

$$= \frac{1.5\text{mA} \cdot 10\text{ms}}{4.7\text{V} - 3.4\text{V}} = 11.5\mu\text{F}$$

R1 has to limit the Zener diode reverse current to a value below its maximum rating. This determines R1's minimum value.

$$R_{\text{MIN}} = \frac{V1 - V2}{I_{Z(\text{MAX})}} = \frac{12\text{V} - 4.7\text{V}}{0.1\text{mA}} = 73\text{k}\Omega$$

The maximum value of R1 is determined by the V2 pin input current and the Zener diode reverse leakage current:

$$R_{\text{MAX}} = \frac{V1 - V2}{I_{Z(\text{MIN})} + V2 / R_{\text{IN}(\text{MIN})}}$$

$$= \frac{12\text{V} - 4.7\text{V}}{0.01\text{mA} + 4.7\text{V} / 400\text{k}} = 336\text{k}\Omega$$

### Low Cost Multipoint Temperature Control System

Figure 6 in the Typical Applications section illustrates a low cost, 4-point temperature control system, which is suited for such commercial applications as electric ovens and dryers.

The temperature sensors are four 2N3904 diode-connected BJTs, strategically placed inside the oven/dryer, which are forward-biased at constant current through 10k resistors connected to the regulated 3.3V pin. The diode voltages, which exhibit a negative 2.2mV/°C temperature coefficient, are monitored on the V2 to V5 inputs, set to the precision range.

The OV faults, corresponding to under-the-limit temperatures, are mapped into GPIO1, which controls the electric heater through a power MOSFET switch and a relay.

The UV faults, corresponding to over-the-limit temperatures, are mapped into GPIO2, which controls the cooling fan through a power MOSFET switch.

A microprocessor is used to program the appropriate temperature limits into the LTC2933, via the I<sup>2</sup>C interface.

All faults are also mapped into GPIO3, which alerts the microprocessor on system status.

The diode connected in series with the fan 12V supply protects the LTC2933 against inductive voltage spikes which can propagate on its V1 supply pin through the common 12V line.

Such a low cost system can control oven/dryer temperature within  $\pm 10^\circ\text{C}$  accuracy, over a 50°C to 150°C range, after proper calibration.

## TYPICAL APPLICATIONS

### Seven-Power Supply Monitor

Figure 7 in the Typical Applications section illustrates how to use the LTC2933 auxiliary comparators to expand power supply monitoring to seven channels. The system is powered by a 12V source, which is also monitored. The 9V rail can be monitored, in addition to the six input channels (12V, 5V, 3.3V, 2.5V, 1.8V and 24V), using an external resistive divider which feeds the OV and UV tap voltages to the auxiliary comparators on inputs GPI1 and GPI2.

Since the auxiliary comparators' thresholds are fixed at  $0.5V \pm 10mV$ , to monitor a  $9V \pm 10\%$  power supply, the following equations apply:

$$\frac{R2+R3}{R1+R2+R3} = \frac{0.51V}{0.9 \cdot 9V}$$

$$\frac{R3}{R1+R2+R3} = \frac{0.49V}{1.1 \cdot 9V}$$

For  $R3 = 8.87k$ , the equations yield:  $R2 = 2.4k$  and  $R1 = 168k$ .

The GPI1 comparator monitors the UV limit and is programmed for negative polarity. The GPI2 comparator monitors the OV limit and is programmed for positive polarity.

A second resistive divider is used to divide the 24V rail voltage down to 1.08V, in order to use the low leakage, low range of the V5 channel.

## TYPICAL APPLICATIONS

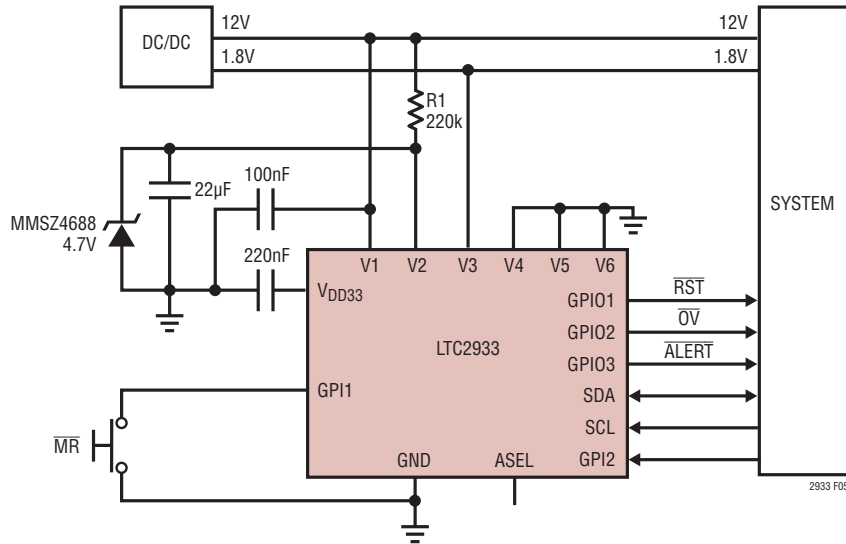

NOTE: INTERNAL GPIO1-3 PULL-UP ENABLED

Figure 5. 2-Channel Voltage Monitoring with EEPROM Fault Storage Power Backup

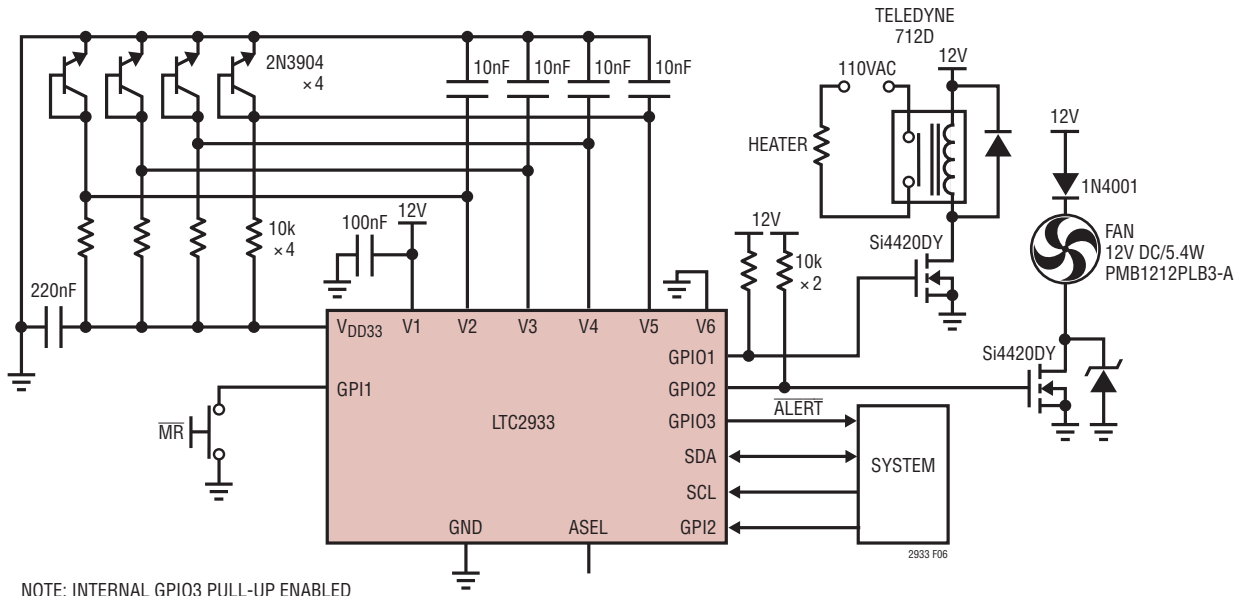

NOTE: INTERNAL GPIO3 PULL-UP ENABLED

Figure 6. Low Cost Multipoint Temperature Control System

## PACKAGE DESCRIPTION

Please refer to <http://www.linear.com/designtools/packaging/> for the most recent package drawings.

**DHD Package**  
**16-Lead Plastic DFN (5mm × 4mm)**  
 (Reference LTC DWG # 05-08-1707 Rev A)

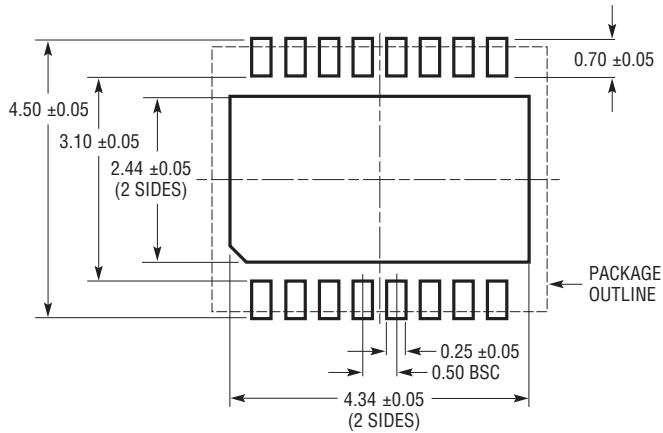

**RECOMMENDED SOLDER PAD PITCH AND DIMENSIONS**

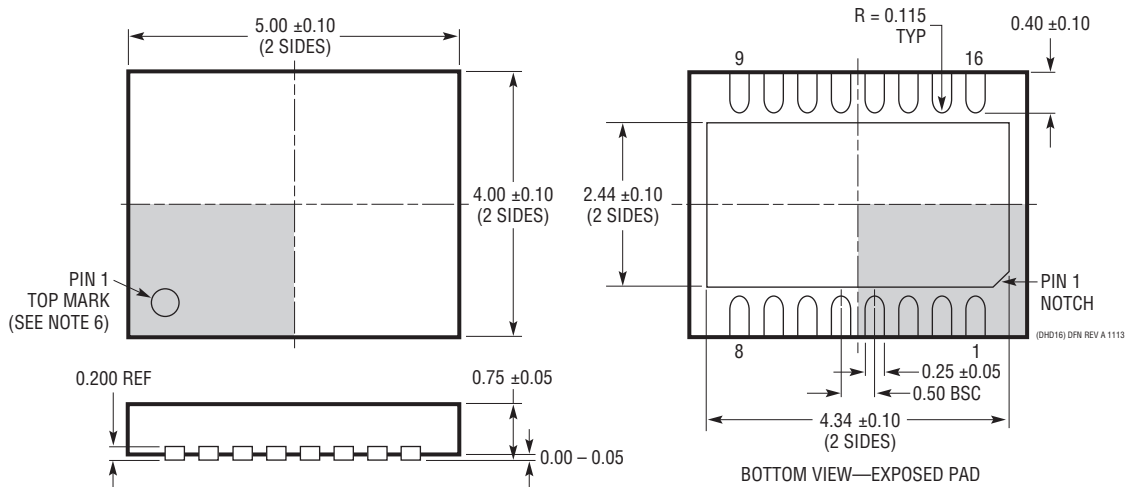

**NOTE:**

1. DRAWING PROPOSED TO BE MADE VARIATION OF VERSION (WJGD-2) IN JEDEC PACKAGE OUTLINE MO-229
2. DRAWING NOT TO SCALE
3. ALL DIMENSIONS ARE IN MILLIMETERS
4. DIMENSIONS OF EXPOSED PAD ON BOTTOM OF PACKAGE DO NOT INCLUDE MOLD FLASH. MOLD FLASH, IF PRESENT, SHALL NOT EXCEED 0.15mm ON ANY SIDE
5. EXPOSED PAD SHALL BE SOLDER PLATED
6. SHADED AREA IS ONLY A REFERENCE FOR PIN 1 LOCATION ON THE TOP AND BOTTOM OF PACKAGE

## PACKAGE DESCRIPTION

Please refer to <http://www.linear.com/designtools/packaging/> for the most recent package drawings.

### GN Package 16-Lead Plastic SSOP (Narrow .150 Inch) (Reference LTC DWG # 05-08-1641 Rev B)

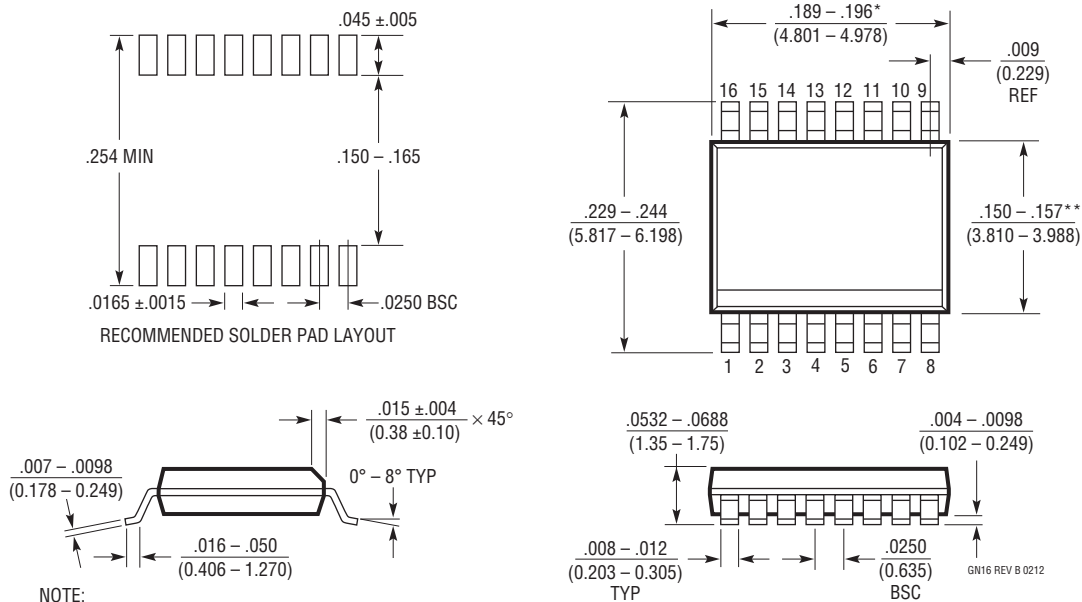

#### NOTE:

1. CONTROLLING DIMENSION: INCHES
2. DIMENSIONS ARE IN  $\frac{\text{INCHES}}{\text{MILLIMETERS}}$
3. DRAWING NOT TO SCALE
4. PIN 1 CAN BE BEVEL EDGE OR A DIMPLE

\*DIMENSION DOES NOT INCLUDE MOLD FLASH. MOLD FLASH SHALL NOT EXCEED 0.006" (0.152mm) PER SIDE

\*\*DIMENSION DOES NOT INCLUDE INTERLEAD FLASH. INTERLEAD FLASH SHALL NOT EXCEED 0.010" (0.254mm) PER SIDE

## TYPICAL APPLICATION

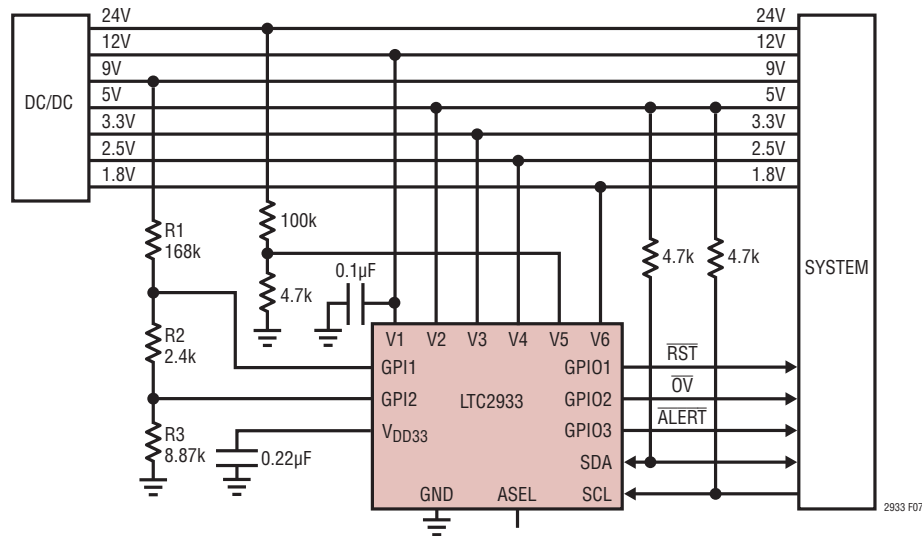

NOTE: INTERNAL GPIO1-3 PULL-UP ENABLED

Figure 7. 7-Power Supply Monitor

## RELATED PARTS

PART NUMBER	DESCRIPTION	COMMENTS
<a href="#">LTC2908</a>	Precision 6-Input Supply Monitor	Reset: $V_{CC} = 0.5V$ , $\pm 1.5\%$ Accuracy Over Temperature, Internal $V_{CC}$ Auto Select
<a href="#">LTC2910</a>	Octal Positive/Negative Voltage Monitor	8 Adjustable Inputs (0.5V), $\pm 1.5\%$ Accuracy, Input Glitch Rejection, Pin-Selectable Input Polarity
<a href="#">LTC2930</a>	Configurable 6-Supply Monitor with Adjustable Reset Timer, Manual Reset	16 Selectable Thresholds
<a href="#">LTC2931</a>	Configurable 6-Supply Monitor with Adjustable Reset and Watchdog Timers	16 Selectable Thresholds, Reset Timer, Separate Voltage Monitor Outputs
<a href="#">LTC2932</a>	Configurable 6-Supply Monitor with Adjustable Reset Timer and Supply Tolerance	16 Selectable Thresholds, Threshold Tolerance, Separate Voltage Monitor Outputs
<a href="#">LTC2938</a>	Configurable 4-Supply Monitor with Processor Supervisory Functions	16 Selectable Thresholds, Adjustable Reset Timer, Watchdog Timeout, Watchdog Status Output
<a href="#">LTC2939</a>	Configurable 6-Supply Monitor with Processor Supervisory Functions	16 Selectable Thresholds, Adjustable Reset Timer, Watchdog Timeout, Watchdog Status Output
<a href="#">LTC2977</a>	8-Channel PMBus Power System Manager	0.25% TUE 16-Bit ADC, Voltage/Temperature Monitoring and Supervision
<a href="#">LTC2974</a>	4-Channel PMBus Power System Manager	0.25% TUE 16-Bit ADC, Voltage/Current/Temperature Monitoring and Supervision
<a href="#">LTC2970</a>	Dual I <sup>2</sup> C Power Supply Monitor and Margining Controller	Monitors Voltage and Current on Two Power Supplies. Margins to 0.5% Accuracy