

Multi-Sensor High Accuracy Digital Temperature Measurement System

FEATURES

- Directly Digitize RTDs, Thermocouples, Thermistors and Diodes
- Single 2.85V to 5.25V Supply
- Results Reported in °C or °F
- 20 Flexible Inputs Allow Interchanging Sensors
- Automatic Thermocouple Cold Junction Compensation
- Built-In Standard and User-Programmable Coefficients for Thermocouples, RTDs and Thermistors
- Configurable 2-, 3- or 4-Wire RTD Configurations
- Measures Negative Thermocouple Voltages
- Automatic Burn Out, Short-Circuit and Fault Detection
- Buffered Inputs Allow External Protection
- Simultaneous 50Hz/60Hz Rejection
- Includes 15ppm/°C (Max) Reference (I-Grade)

APPLICATIONS

- Direct Thermocouple Measurements
- Direct RTD Measurements
- Direct Thermistor Measurements
- Custom Sensor Applications

DESCRIPTION

The **LTC[®]2983** measures a wide variety of temperature sensors and digitally outputs the result, in °C or °F, with 0.1°C accuracy and 0.001°C resolution. The LTC2983 can measure the temperature of virtually all standard (type B, E, J, K, N, S, R, T) or custom thermocouples, automatically compensate for cold junction temperatures and linearize the results. The device can also measure temperature with standard 2-, 3- or 4-wire RTDs, thermistors and diodes. It has 20 reconfigurable analog inputs enabling many sensor connections and configuration options. The LTC2983 includes excitation current sources and fault detection circuitry appropriate for each type of temperature sensor.

The LTC2983 allows direct interfacing to ground referenced sensors without the need for level shifters, negative supply voltages, or external amplifiers. All signals are buffered and simultaneously digitized with three high accuracy, 24-bit $\Delta\Sigma$ ADCs, driven by an internal 15ppm/°C (maximum) reference.

LT, LTC, LTM, Linear Technology and the Linear logo are registered trademarks of Linear Technology Corporation. All other trademarks are the property of their respective owners. Patents Pending

TYPICAL APPLICATION

Thermocouple Measurement with Automatic Cold Junction Compensation

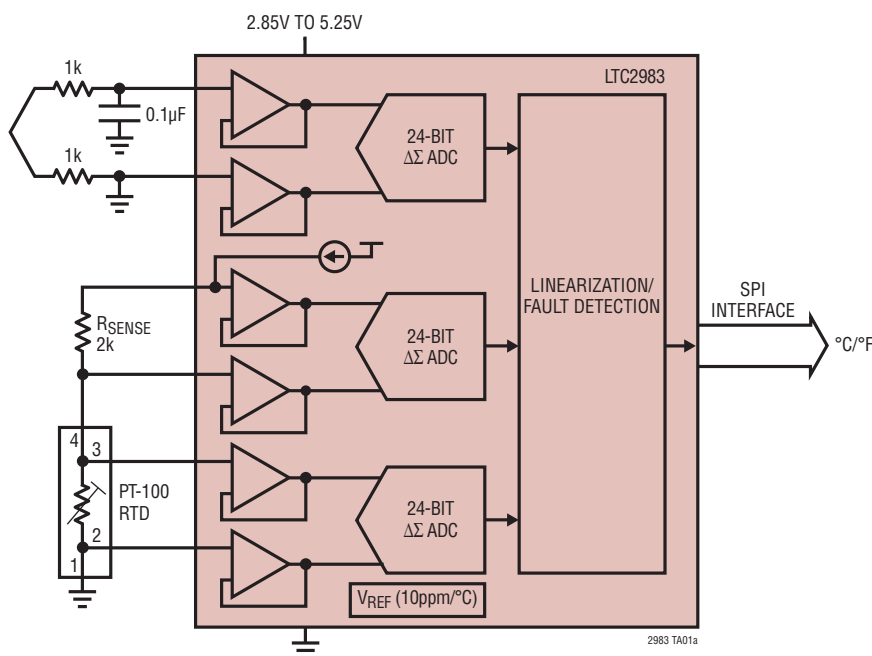

Typical Temperature Error Contribution

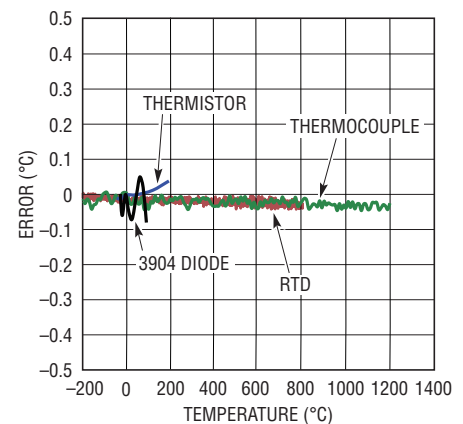

2983 TA01b

TABLE OF CONTENTS

Features	1
Applications	1
Typical Application	1
Description.....	1
Absolute Maximum Ratings.....	3
Order Information	3
Complete System Electrical Characteristics.....	3
Pin Configuration	3
ADC Electrical Characteristics	4
Reference Electrical Characteristics.....	4
Digital Inputs and Digital Outputs	5
Typical Performance Characteristics	6
Pin Functions	9
Block Diagram.....	10
Test Circuits	11
Timing Diagram.....	11
Overview	12
Applications Information	16
Thermocouple Measurements	21
Diode Measurements.....	24
RTD Measurements	28
Thermistor Measurements.....	43
Direct ADC Measurements.....	55
Supplemental Information.....	55
Fault Protection and Anti-Aliasing.....	57
2- and 3-Cycle Conversion Modes.....	57
Running Conversions Consecutively on Multiple Channels.....	58
MUX Configuration Delay.....	58
Global Configuration Register.....	59
Custom Thermocouples	59
Custom RTDs	62
Custom Thermistors	65
Package Description	70
Revision History	71
Typical Application	72
Related Parts	72

ABSOLUTE MAXIMUM RATINGS

(Notes 1, 2)

Supply Voltage (V_{DD})	-0.3V to 6V
Analog Input Pins (CH1 to CH20, COM)	-0.3V to ($V_{DD} + 0.3V$)
Input Current (CH1 to CH20, COM)	$\pm 15mA$
Digital Inputs (\overline{CS} , SDI, SCK, \overline{RESET})	-0.3V to ($V_{DD} + 0.3V$)
Digital Outputs (SDO, INTERRUPT)	-0.3V to ($V_{DD} + 0.3V$)
V_{REFP}	-0.3V to 2.8V
Q_1 , Q_2 , Q_3 , LDO, V_{REFOUT} , V_{REF_BVP} (Note 17)	
Reference Short-Circuit Duration	Indefinite
Operating Temperature Range	
LTC2983C	0°C to 70°C
LTC2983I	-40°C to 85°C
LTC2983H	-40°C to 125°C

PIN CONFIGURATION

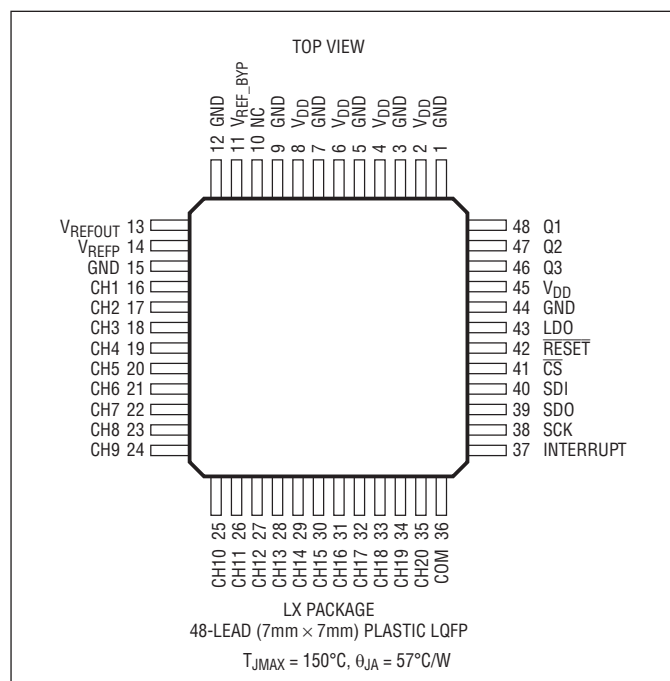

ORDER INFORMATION

LEAD FREE FINISH	TRAY	PART MARKING*	PACKAGE DESCRIPTION	TEMPERATURE RANGE
LTC2983CLX#PBF	LTC2983CLX#PBF	LTC2983LX	48-Lead (7mm × 7mm) LQFP	0°C to 70°C
LTC2983ILX#PBF	LTC2983ILX#PBF	LTC2983LX	48-Lead (7mm × 7mm) LQFP	-40°C to 85°C
LTC2983HLX#PBF	LTC2983HLX#PBF	LTC2983LX	48-Lead (7mm × 7mm) LQFP	-40°C to 125°C

Consult LTC Marketing for parts specified with wider operating temperature ranges. *The temperature grade is identified by a label on the shipping container. For more information on lead free part marking, go to: <http://www.linear.com/leadfree/>

COMPLETE SYSTEM ELECTRICAL CHARACTERISTICS

The ● denotes the specifications which apply over the full operating temperature range, otherwise specifications are at $T_A = 25^{\circ}C$.

PARAMETER	CONDITIONS	MIN	TYP	MAX	UNITS
Supply Voltage		● 2.85		5.25	V
Supply Current			● 15	20	mA
Sleep Current			● 25	60	μA
Input Range	All Analog Input Channels	● -0.05		$V_{DD} - 0.3$	V
Output Rate	Two Conversion Cycle Mode (Notes 6, 9)	● 150	164	170	ms
Output Rate	Three Conversion Cycle Mode (Notes 6, 9)	● 225	246	255	ms
Input Common Mode Rejection	50Hz/60Hz (Note 4)	● 120			dB
Input Normal Mode Rejection	60Hz (Notes 4, 7)	● 120			dB

COMPLETE SYSTEM ELECTRICAL CHARACTERISTICS

The ● denotes the specifications which apply over the full operating temperature range, otherwise specifications are at $T_A = 25^\circ\text{C}$.

PARAMETER	CONDITIONS		MIN	TYP	MAX	UNITS
Input Normal Mode Rejection	50Hz (Notes 4, 8)	●	120			dB
Input Normal Mode Rejection	50Hz/60Hz (Notes 4, 6, 9)	●	75			dB
Power-On Reset Threshold				2.25		V
Analog Power-Up	(Note 11)	●			100	ms
Digital Initialization	(Note 12)	●			100	ms

ADC ELECTRICAL CHARACTERISTICS

The ● denotes the specifications which apply over the full operating temperature range, otherwise specifications are at $T_A = 25^\circ\text{C}$.

PARAMETER	CONDITIONS		MIN	TYP	MAX	UNITS
Resolution (No Missing Codes)	$-F_S \leq V_{IN} \leq +F_S$	●	24			Bits
Integral Nonlinearity	$V_{IN(CM)} = 1.25\text{V}$ (Note 15)	●		2	30	ppm of V_{REF}
Offset Error		●		0.5	2	μV
Offset Error Drift	(Note 4)	●		10	20	$\text{nV}/^\circ\text{C}$
Positive Full-Scale Error	(Notes 3, 15)	●			100	ppm of V_{REF}
Positive Full-Scale Drift	(Notes 3, 15)	●		0.1	0.5	ppm of $V_{REF}/^\circ\text{C}$
Input Leakage	(Note 18)	●			1	nA
	H-Grade	●			10	nA
Negative Full-Scale Error	(Notes 3, 15)	●			100	ppm of V_{REF}
Negative Full-Scale Drift	(Notes 3, 15)	●		0.1	0.5	ppm of $V_{REF}/^\circ\text{C}$
Input Referred Noise	(Note 5)	●		0.8	1.5	μV_{RMS}
	H-Grade	●			2.0	μV_{RMS}
Common Mode Input Range		●	-0.05		$V_{DD} - 0.3$	V
RTD Excitation Current	(Note 16)	●	-25	Table 30	25	%
RTD Excitation Current Matching	Continuously Calibrated	●	Error within Noise Level of ADC			
Thermistor Excitation Current	(Note 16)	●	-37.5	Table 53	37.5	%

REFERENCE ELECTRICAL CHARACTERISTICS

The ● denotes the specifications which apply over the full operating temperature range, otherwise specifications are at $T_A = 25^\circ\text{C}$.

PARAMETER	CONDITIONS		MIN	TYP	MAX	UNITS
Output Voltage	V_{REFOUT} (Note 10)		2.49		2.51	V
Output Voltage Temperature Coefficient	I-Grade, H-Grade	●		3	15	ppm/ $^\circ\text{C}$
Output Voltage Temperature Coefficient	C-Grade	●		3	20	ppm/ $^\circ\text{C}$
Line Regulation		●			10	ppm/V
Load Regulation	$I_{OUT(SOURCE)} = 100\mu\text{A}$	●			5	mV/mA
	$I_{OUT(SINK)} = 100\mu\text{A}$	●			5	mV/mA
Output Voltage Noise	$0.1\text{Hz} \leq f \leq 10\text{Hz}$			4		μV_{P-P}
	$10\text{Hz} \leq f \leq 1\text{kHz}$			4.5		μV_{P-P}
Output Short-Circuit Current	Short V_{REFOUT} to GND			40		mA
	Short V_{REFOUT} to V_{DD}			30		mA
Turn-On Time	0.1% Setting, $C_{LOAD} = 1\mu\text{F}$			115		μs
Long Term Drift of Output Voltage (Note 13)				60		ppm/ $\sqrt{\text{kHz}}$
Hysteresis (Note 14)	$\Delta T = 0^\circ\text{C}$ to 70°C			30		ppm
	$\Delta T = -40^\circ\text{C}$ to 85°C			70		ppm

DIGITAL INPUTS AND DIGITAL OUTPUTS

full operating temperature range, otherwise specifications are at $T_A = 25^\circ\text{C}$.

The ● denotes the specifications which apply over the

SYMBOL	PARAMETER	CONDITIONS		MIN	TYP	MAX	UNITS
	External SCK Frequency Range		●	0		2	MHz
	External SCK LOW Period		●	250			ns
	External SCK HIGH Period		●	250			ns
t_1	$\overline{\text{CS}}\downarrow$ to SDO Valid		●	0		200	ns
t_2	$\overline{\text{CS}}\uparrow$ to SDO Hi-Z		●	0		200	ns
t_3	$\overline{\text{CS}}\downarrow$ to SCK \uparrow		●	100			ns
t_4	SCK \downarrow to SDO Valid		●			225	ns
t_5	SDO Hold After SCK \downarrow		●	10			ns
t_6	SDI Setup Before SCK \uparrow		●	100			ns
t_7	SDI HOLD After SCK \uparrow		●	100			ns
	High Level Input Voltage	$\overline{\text{CS}}$, SDI, SCK, $\overline{\text{RESET}}$	●	$V_{\text{DD}} - 0.5$			V
	Low Level Input Voltage	$\overline{\text{CS}}$, SDI, SCK, $\overline{\text{RESET}}$	●			0.5	V
	Digital Input Current	$\overline{\text{CS}}$, SDI, SCK, $\overline{\text{RESET}}$	●	-10		10	μA
	Digital Input Capacitance	$\overline{\text{CS}}$, SDI, SCK, $\overline{\text{RESET}}$			10		pF
	LOW Level Output Voltage (SDO, INTERRUPT)	$I_0 = -800\mu\text{A}$	●			0.4	V
	High Level Output Voltage (SDO, INTERRUPT)	$I_0 = 1.6\text{mA}$	●	$V_{\text{DD}} - 0.5$			V
	Hi-Z Output Leakage (SDO)		●	-10		10	μA

Note 1: Stresses beyond those listed under Absolute Maximum Ratings may cause permanent damage to the device. Exposure to any Absolute Maximum Rating condition for extended periods may affect device reliability and lifetime.

Note 2: All voltage values are with respect to GND.

Note 3: Full scale ADC error. Measurements do not include reference error.

Note 4: Guaranteed by design, not subject to test.

Note 5: The input referred noise includes the contribution of internal calibration operations.

Note 6: MUX configuration delay = default 1ms

Note 7: Global configuration set to 60Hz rejection.

Note 8: Global configuration set to 50Hz rejection.

Note 9: Global configuration default 50Hz/60Hz rejection.

Note 10: The exact value of V_{REF} is stored in the LTC2983 and used for all measurement calculations. Temperature coefficient is measured by dividing the maximum change in output voltage by the specified temperature range.

Note 11: Analog power-up. Command status register inaccessible during this time.

Note 12: Digital initialization. Begins at the conclusion of Analog Power-Up. Command status register is 0×80 at the beginning of digital initialization and 0×40 at the conclusion.

Note 13: Long-term stability typically has a logarithmic characteristic and therefore, changes after 1000 hours tend to be much smaller than before that time. Total drift in the second thousand hours is normally less

than one third that of the first thousand hours with a continuing trend toward reduced drift with time. Long-term stability will also be affected by differential stresses between the IC and the board material created during board assembly.

Note 14: Hysteresis in output voltage is created by package stress that differs depending on whether the IC was previously at a higher or lower temperature. Output voltage is always measured at 25°C , but the IC is cycled to the hot or cold temperature limit before successive measurements. Hysteresis measures the maximum output change for the averages of three hot or cold temperature cycles. For instruments that are stored at well controlled temperatures (within 20 or 30 degrees of operational temperature), it is usually not a dominant error source. Typical hysteresis is the worst-case of 25°C to cold to 25°C or 25°C to hot to 25°C , preconditioned by one thermal cycle.

Note 15: Differential Input Range is $\pm V_{\text{REF}}/2$.

Note 16: RTD and thermistor measurements are made ratiometrically. As a result current source excitation variation does not affect absolute accuracy. Choose an excitation current such that largest sensor or R_{SENSE} resistance value, when driven by the nominal excitation current, will drop 1V or less. The extended ADC input range will accommodate variation in excitation current and the ratiometric calculation will negate the absolute value of the excitation current.

Note 17: Do not apply voltage or current sources to these pins. They must be connected to capacitive loads only, otherwise permanent damage may occur.

Note 18: Input leakage measured with $V_{\text{IN}} = -10\text{mV}$ and $V_{\text{IN}} = 2.5\text{V}$.

TYPICAL PERFORMANCE CHARACTERISTICS

Type J Thermocouple Error and RMS Noise vs Temperature

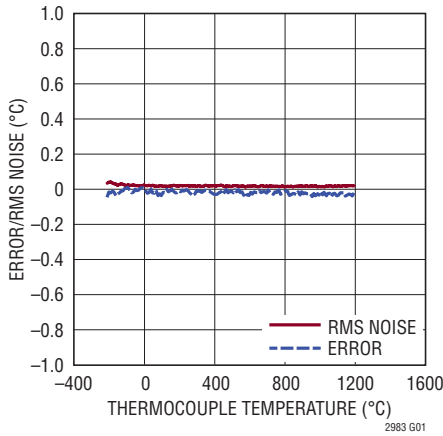

Type K Thermocouple Error and RMS Noise vs Temperature

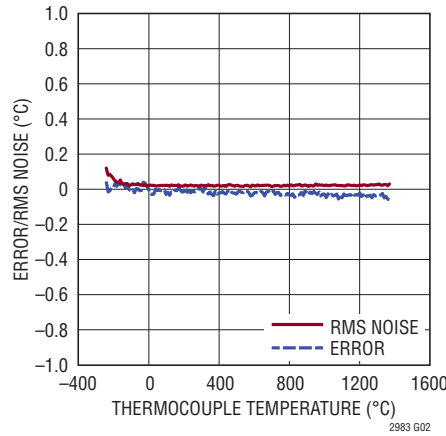

Type N Thermocouple Error and RMS Noise vs Temperature

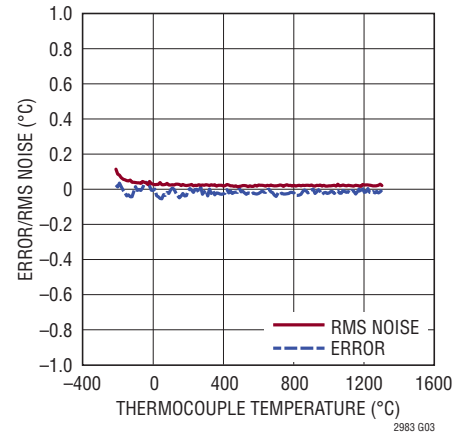

Type R Thermocouple Error and RMS Noise vs Temperature

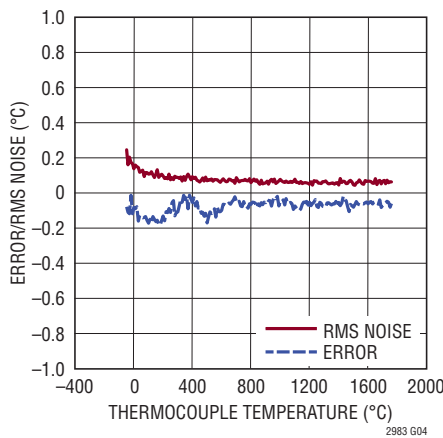

Type S Thermocouple Error and RMS Noise vs Temperature

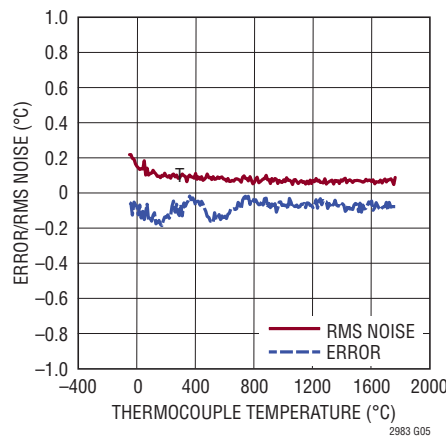

Type T Thermocouple Error and RMS Noise vs Temperature

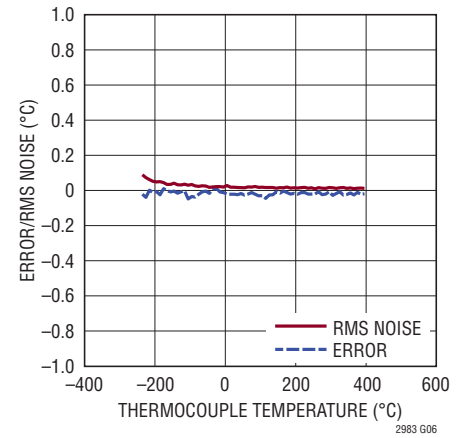

Type E Thermocouple Error and RMS Noise vs Temperature

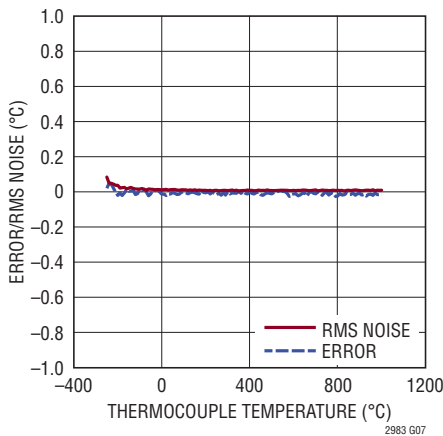

Type B Thermocouple Error and RMS Noise vs Temperature

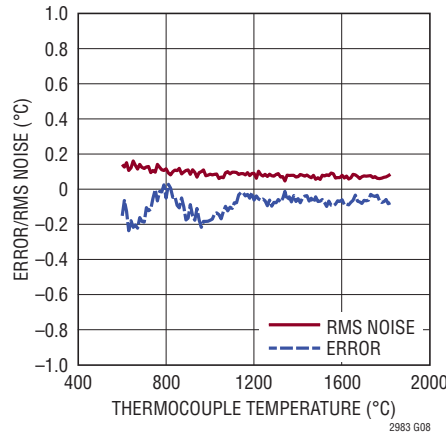

RTD PT-1000 Error and RMS Noise vs Temperature

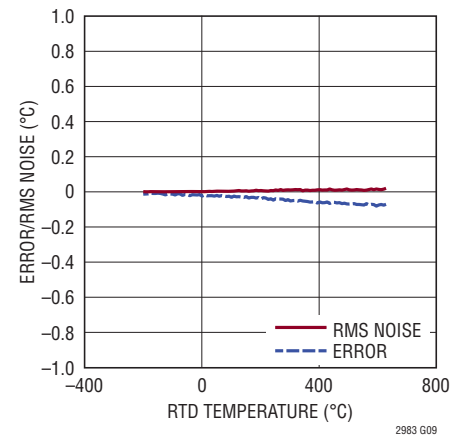

TYPICAL PERFORMANCE CHARACTERISTICS

RTD PT-200 Error and RMS Noise vs Temperature

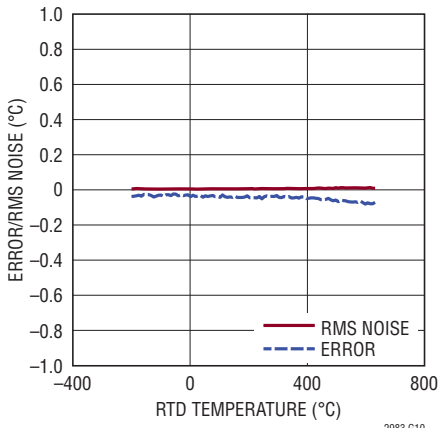

RTD PT-100 Error and RMS Noise vs Temperature

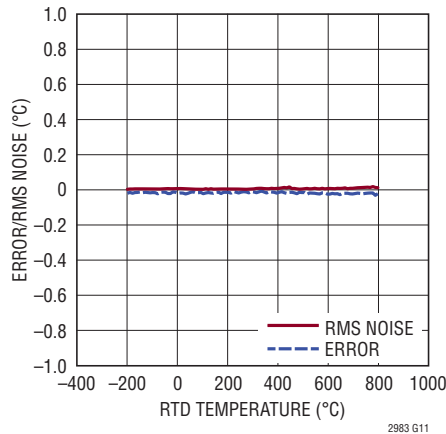

RTD NI-120 RTD Error and RMS Noise vs Temperature

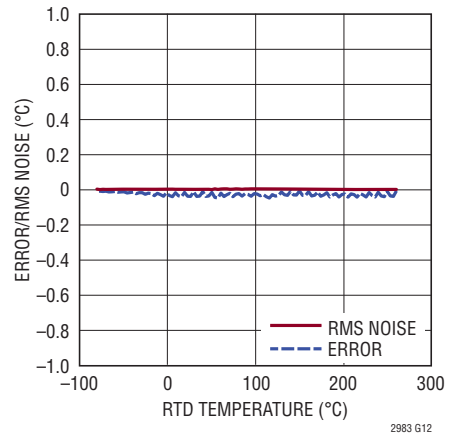

2.252k Thermistor Error vs Temperature

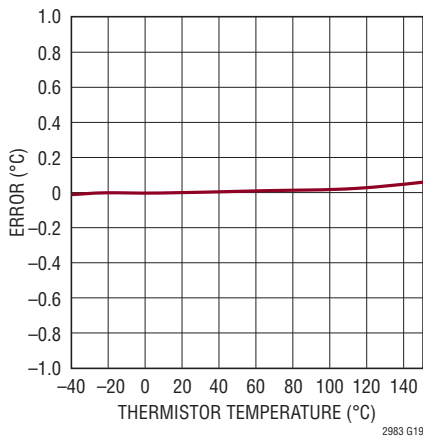

3k Thermistor Error vs Temperature

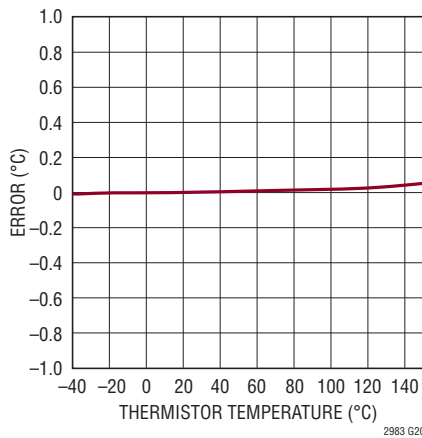

5k Thermistor Error vs Temperature

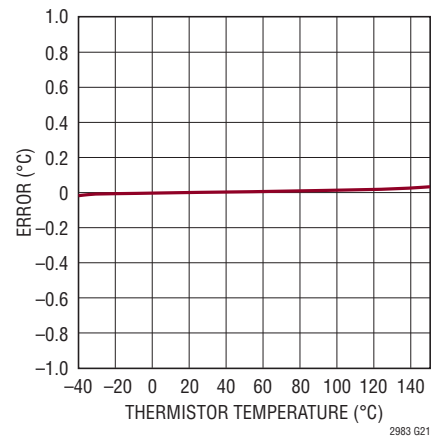

10k Thermistor Error vs Temperature

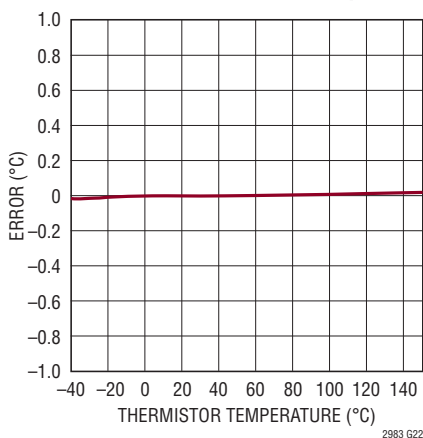

30k Thermistor Error vs Temperature

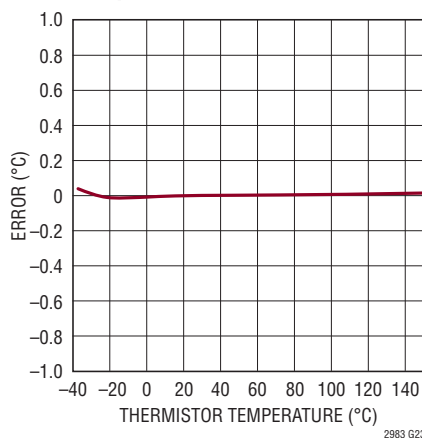

YSI-400 Thermistor Error vs Temperature

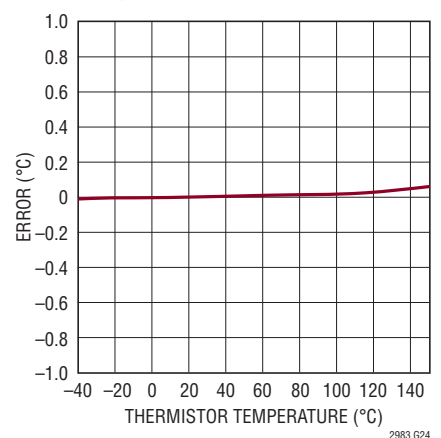

TYPICAL PERFORMANCE CHARACTERISTICS

Diode Error and Repeatability vs Temperature

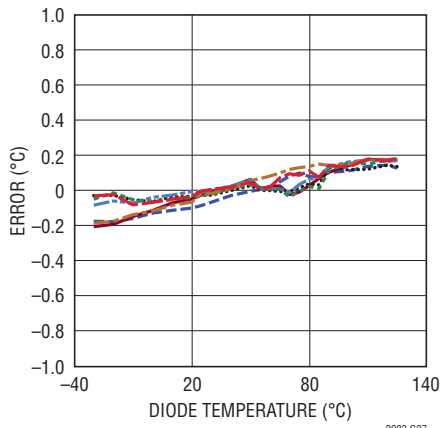

Offset vs Temperature

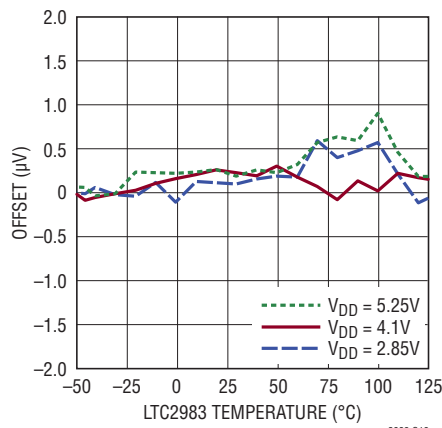

Noise vs Temperature

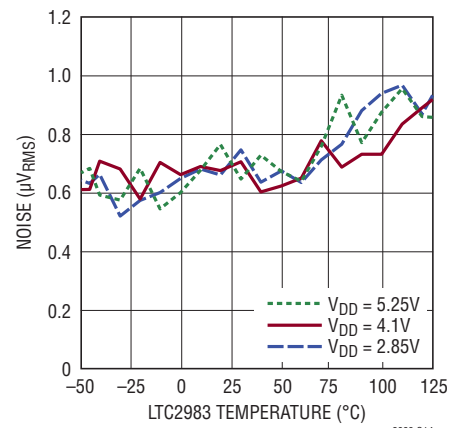

I_{SLEEP} vs Temperature

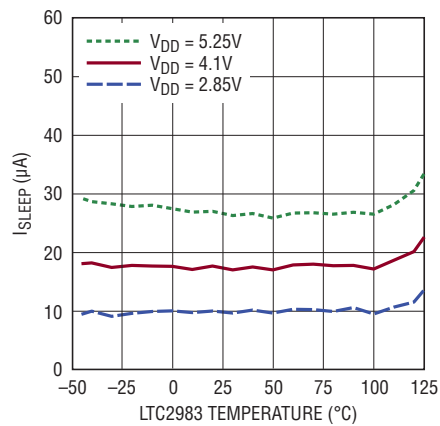

One Shot Conversion Current vs Temperature

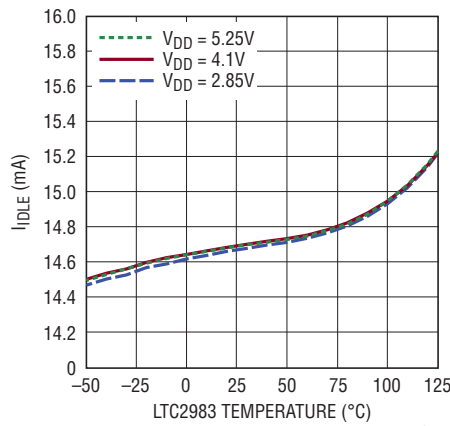

V_{REFOUT} vs Temperature

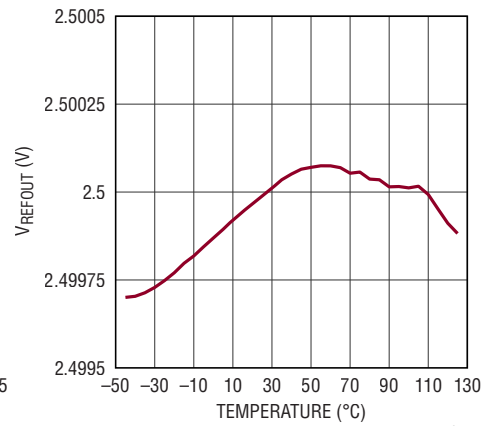

Channel Input Leakage Current vs Temperature

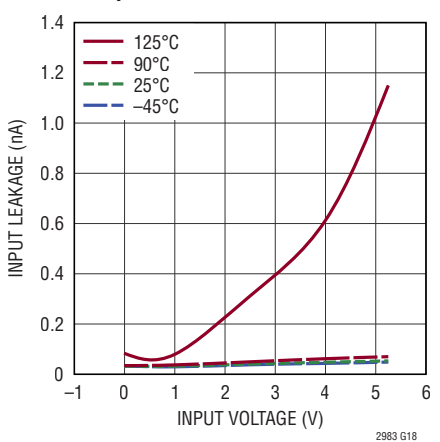

Adjacent Channel Offset Error vs Input Fault Voltage (V_{DD} = 5V)

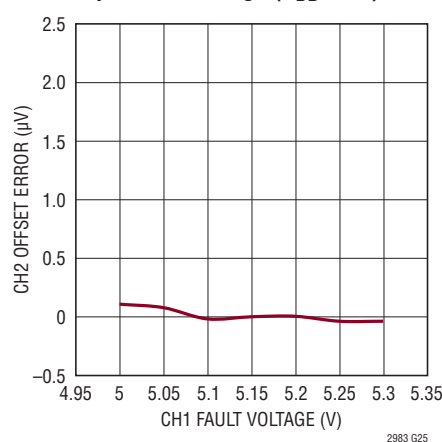

Adjacent Channel Offset Error vs Input Fault Voltage

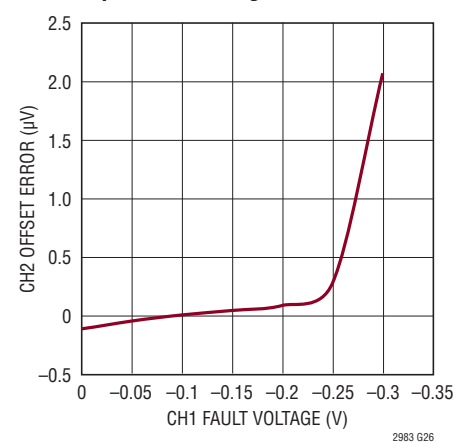

PIN FUNCTIONS

GND (Pins 1, 3, 5, 7, 9, 12, 15, 44): Ground. Connect each of these pins to a common ground plane through a low impedance connection. All eight pins must be grounded for proper operation.

V_{DD} (Pins 2, 4, 6, 8, 45): Analog Power Supply. Tie all five pins together and bypass as close as possible to the device, to ground with a 0.1µF capacitor.

V_{REF_BYP} (Pin 11): Internal Reference Power. This is an internal supply pin, do not load this pin with external circuitry. Decouple with a 0.1µF capacitor to GND.

V_{REFOUT} (Pin 13): Reference Output Voltage. Short to V_{REFP}. A minimum 1µF capacitor to ground is required. Do not load this pin with external circuitry.

V_{REFP} (Pin 14): Positive Reference Input. Tie to V_{REFOUT}.

CH1 to CH20 (Pin 16 to Pin 35): Analog Inputs. May be programmed for single-ended, differential, or ratiometric operation. The voltage on these pins can have any value between GND – 50mV and V_{DD} – 0.3V. Unused pins can be grounded or left floating.

COM (Pin 36): Analog Input. The common negative input for all single-ended configurations. The voltage on this pin can have any value between GND – 50mV and V_{DD} – 0.3V. This pin is typically tied to ground for temperature measurements.

INTERRUPT (Pin 37): This pin outputs a LOW when the device is busy either during start-up or while a conversion

cycle is in progress. This pin goes HIGH at the conclusion of the start-up state or conversion cycle.

SCK (Pin 38): Serial Clock Pin. Data is shifted out of the device on the falling edge of SCK and latched by the device on the rising edge.

SDO (Pin 39): Serial Data Out. During the data output state, this pin is used as the serial data output. When the chip select pin is HIGH, the SDO pin is in a high impedance state.

SDI (Pin 40): Serial Data Input. Used to program the device. Data is latched on the rising edge of SCK.

$\overline{\text{CS}}$ (Pin 41): Active Low Chip Select. A low on this pin enables the digital input/output. A HIGH on this pin places SDO in a high impedance state. A falling edge on $\overline{\text{CS}}$ marks the beginning of a SPI transaction and a rising edge marks the end.

RESET (Pin 42): Active Low Reset. While this pin is LOW, the device is forced into the reset state. Once this pin is returned HIGH, the device initiates its start-up sequence.

LDO (Pin 43): 2.5V LDO Output. Bypass with a 10µF capacitor to GND. This is an internal supply pin, do not load this pin with external circuitry.

Q3, Q2, Q1 (Pins 46, 47, 48): External Bypass Pins for –200mV integrated Charge Pump. Tie a 10µF X7R capacitor between Q1 and Q2 close to each pin. Tie a 10µF X5R capacitor from Q3 to Ground. These are internal supply pins, do not make additional connections.

BLOCK DIAGRAM

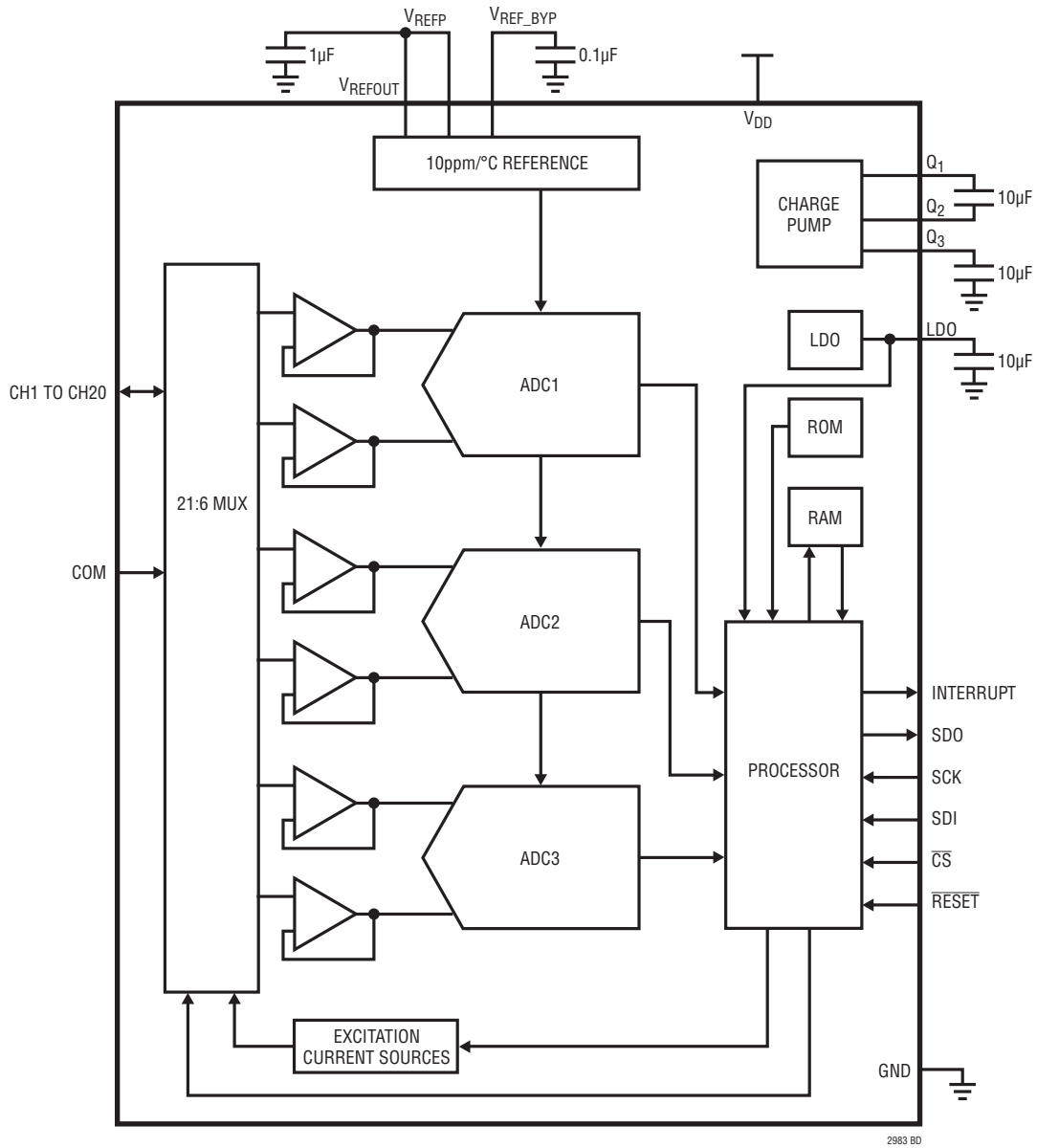

2983 BD

TEST CIRCUITS

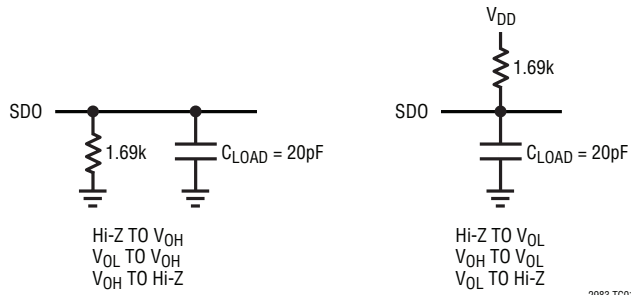

TIMING DIAGRAM

SPI Timing Diagram

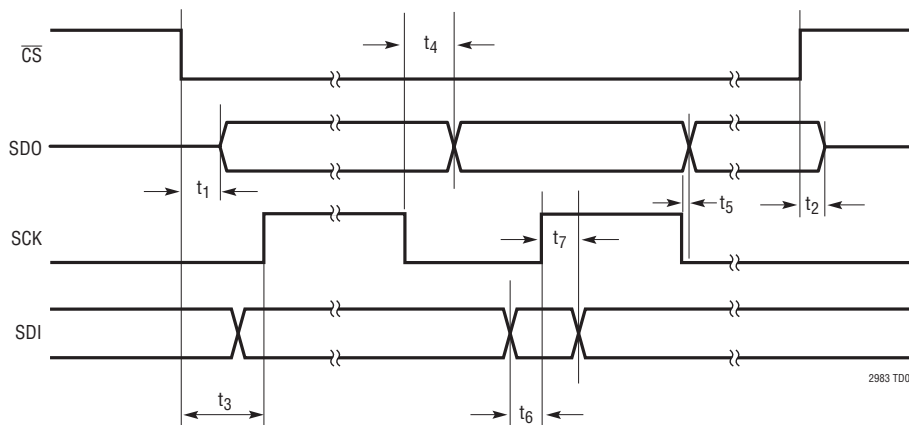

OVERVIEW

The LTC2983 measures temperature using the most common sensors (thermocouples, RTDs, thermistors, and diodes). It includes all necessary active circuitry, switches, measurement algorithms, and mathematical conversions to determine the temperature for each sensor type.

Thermocouples can measure temperatures from as low as -265°C to over 1800°C . Thermocouples generate a voltage as a function of the temperature difference between the tip (thermocouple temperature) and the electrical connection on the circuit board (cold junction temperature). In order to determine the thermocouple temperature, an accurate measurement of the cold junction temperature is required; this is known as cold junction compensation. The cold junction temperature is usually determined by placing a separate (non-thermocouple) temperature sensor at the cold junction. The LTC2983 allows diodes, RTDs, and thermistors to be used as cold junction sensors. In order to convert the voltage output from the thermocouple into a temperature result, a high order polynomial equation (up to 14th order) must be solved. The LTC2983 has these polynomials built in for virtually all standard thermocouples (J, K, N, E, R, S, T, and B). Additionally, inverse polynomials must be solved for the cold junction temperature. The LTC2983 simultaneously measures the thermocouple output and the cold junction temperature and performs all required calculations to report the thermocouple temperature in $^{\circ}\text{C}$ or $^{\circ}\text{F}$. It directly digitizes both positive and negative voltages (down to 50mV below ground) from a single ground referenced supply, includes sensor burn-out detection, and allows external protection/anti-aliasing circuits without the need of buffer circuits.

Diodes are convenient low cost sensor elements and are often used to measure cold junction temperatures in thermocouple applications. Diodes are typically used to measure temperatures from -60°C to 130°C , which is

suitable for most cold junction applications. Diodes generate an output voltage that is a function of temperature and excitation current. When the difference of two diode output voltages are taken at two different excitation current levels, the result (ΔV_{BE}) is proportional to temperature. The LTC2983 accurately generates excitation currents, measures the diode voltages, and calculates the temperature in $^{\circ}\text{C}$ or $^{\circ}\text{F}$.

RTDs and thermistors are resistors that change value as a function of temperature. RTDs can measure temperatures over a wide temperature range, from as low as -200°C to 850°C while thermistors typically operate from -40°C to 150°C . In order to measure one of these devices a precision sense resistor is tied in series with the sensor. An excitation current is applied to the network and a ratiometric measurement is made. The value, in Ω , of the RTD/thermistor can be determined from this ratio. This resistance is used to determine the temperature of the sensor element using a table lookup (RTDs) or solving Steinhart-Hart equations (thermistors). The LTC2983 automatically generates the excitation current, simultaneously measures the sense resistor and thermistor/RTD voltage, calculates the sensor resistance and reports the result in $^{\circ}\text{C}$. The LTC2983 can digitize most RTD types (PT-10, PT-50, PT-100, PT-200, PT-500, PT-1000, and NI-120), has built in coefficients for many curves (American, European, Japanese, and ITS-90), and accommodates 2-wire, 3-wire, and 4-wire configurations. It also includes coefficients for calculating the temperature of standard 2.252k, 3k, 5k, 10k, and 30k thermistors. It can be configured to share one sense resistor among multiple RTDs/thermistors and to rotate excitation current sources to remove parasitic thermal effects.

In addition to built-in linearization coefficients, the LTC2983 provides the means of inserting custom coefficients for both RTDs and thermistors.

OVERVIEW

Table 1. LTC2983 Error Contribution and Peak Noise Errors

SENSOR TYPE	TEMPERATURE RANGE	ERROR CONTRIBUTION	PEAK-TO-PEAK NOISE
Type K Thermocouple	–200°C to 0°C 0°C to 1372°C	$\pm(\text{Temperature} \cdot 0.23\% + 0.05)^\circ\text{C}$ $\pm(\text{Temperature} \cdot 0.12\% + 0.05)^\circ\text{C}$	$\pm 0.08^\circ\text{C}$
Type J Thermocouple	–210°C to 0°C 0°C to 1200°C	$\pm(\text{Temperature} \cdot 0.23\% + 0.05)^\circ\text{C}$ $\pm(\text{Temperature} \cdot 0.10\% + 0.05)^\circ\text{C}$	$\pm 0.07^\circ\text{C}$
Type E Thermocouple	–200°C to 0°C 0°C to 1000°C	$\pm(\text{Temperature} \cdot 0.18\% + 0.05)^\circ\text{C}$ $\pm(\text{Temperature} \cdot 0.10\% + 0.05)^\circ\text{C}$	$\pm 0.06^\circ\text{C}$
Type N Thermocouple	–200°C to 0°C 0°C to 1300°C	$\pm(\text{Temperature} \cdot 0.27\% + 0.08)^\circ\text{C}$ $\pm(\text{Temperature} \cdot 0.10\% + 0.08)^\circ\text{C}$	$\pm 0.13^\circ\text{C}$
Type R Thermocouple	0°C to 1768°C	$\pm(\text{Temperature} \cdot 0.10\% + 0.4)^\circ\text{C}$	$\pm 0.62^\circ\text{C}$
Type S Thermocouple	0°C to 1768°C	$\pm(\text{Temperature} \cdot 0.10\% + 0.4)^\circ\text{C}$	$\pm 0.62^\circ\text{C}$
Type B Thermocouple	400°C to 1820°C	$\pm(\text{Temperature} \cdot 0.10\%)^\circ\text{C}$	$\pm 0.83^\circ\text{C}$
Type T Thermocouple	–250°C to 0°C 0°C to 400°C	$\pm(\text{Temperature} \cdot 0.15\% + 0.05)^\circ\text{C}$ $\pm(\text{Temperature} \cdot 0.10\% + 0.05)^\circ\text{C}$	$\pm 0.09^\circ\text{C}$
External Diode (2 Reading)	–40°C to 85°C	$\pm 0.25^\circ\text{C}$	$\pm 0.05^\circ\text{C}$
External Diode (3 Reading)	–40°C to 85°C	$\pm 0.25^\circ\text{C}$	$\pm 0.2^\circ\text{C}$
Platinum RTD - PT-10, $R_{\text{SENSE}} = 1\text{k}\Omega$	–200°C to 800°C	$\pm 0.1^\circ\text{C}$	$\pm 0.05^\circ\text{C}$
Platinum RTD - PT-100, $R_{\text{SENSE}} = 2\text{k}\Omega$	–200°C to 800°C	$\pm 0.1^\circ\text{C}$	$\pm 0.05^\circ\text{C}$
Platinum RTD - PT-500, $R_{\text{SENSE}} = 2\text{k}\Omega$	–200°C to 800°C	$\pm 0.1^\circ\text{C}$	$\pm 0.02^\circ\text{C}$
Platinum RTD - PT-1000, $R_{\text{SENSE}} = 2\text{k}\Omega$	–200°C to 800°C	$\pm 0.1^\circ\text{C}$	$\pm 0.01^\circ\text{C}$
Thermistor, $R_{\text{SENSE}} = 10\text{k}\Omega$	–40°C to 85°C	$\pm 0.1^\circ\text{C}$	$\pm 0.01^\circ\text{C}$

Table 1 shows the estimated system accuracy and noise associated with specific temperature sensing devices. System accuracy and peak-to-peak noise include the effects of the ADC, internal amplifiers, excitation current sources, and integrated reference for I-grade parts. Accuracy and noise are the worst-case errors calculated from the guaranteed maximum ADC and reference specifications. Peak-to-peak noise values are calculated at 0°C (except type B was calculated at 400°C) and diode measurements use AVG = ON mode.

Thermocouple errors do not include the errors associated with the cold junction measurement. Errors associated with a specific cold junction sensor within the operating temperature range can be combined with the errors for a given thermocouple for total temperature measurement accuracy.

OVERVIEW

Memory Map

The LTC2983 channel assignment, configuration, conversion start, and results are all accessible via the RAM (see Table 2A). Table 2B details the valid SPI instruction bytes for accessing memory. The channel conversion results are mapped into memory locations 0x010 to 0x05F and can be read using the SPI interface as shown in Figure 1. A read is initiated by sending the read instruction byte = 0x03

followed by the address and then data. Channel assignment data resides in memory locations 0x200 to 0x24F and can be programmed via the SPI interface as shown in Figure 2. A write is initiated by sending the write instruction byte = 0x02 followed by the address and then data. Conversions are initiated by writing the conversion control byte (see Table 6) into memory location 0x000 (command status register).

Table 2A. Memory Map

LTC2983 MEMORY MAP				
SEGMENT	START ADDRESS	END ADDRESS	SIZE (BYTES)	DESCRIPTION
Command Status Register	0x000	0x000	1	See Table 6, Initiate Conversion, Sleep Command
Reserved	0x001	0x00F	15	
Temperature Result Memory 20 Words - 80 Bytes	0x010	0x05F	80	See Tables 8 to 10, Read Result
Reserved	0x060	0x0EF	144	
Global Configuration Register	0x0F0	0x0F0	1	
Reserved	0x0F1	0x0F3	3	
Measure Multiple Channels Bit Mask	0x0F4	0x0F7	4	See Tables 65, 66, Run Multiple Conversions
Reserved	0x0F8	0x0F8	1	
Reserved	0x0F9	0x0FE	6	
Mux Configuration Delay	0x0FF	0x0FF	1	See MUX Configuration Delay Section of Data Sheet
Reserved	0x100	0x1FF	256	
Channel Assignment Data	0x200	0x24F	80	See Tables 3, 4, Channel Assignment
Custom Sensor Table Data	0x250	0x3CF	384	
Reserved	0x3D0	0x3FF	48	

Table 2B. SPI Instruction Byte

INSTRUCTION	SPI INSTRUCTION BYTE	DESCRIPTION
Read	0b00000011	See Figure 1
Write	0b00000010	See Figure 2
No Opp	0bXXXXXX0X	

OVERVIEW

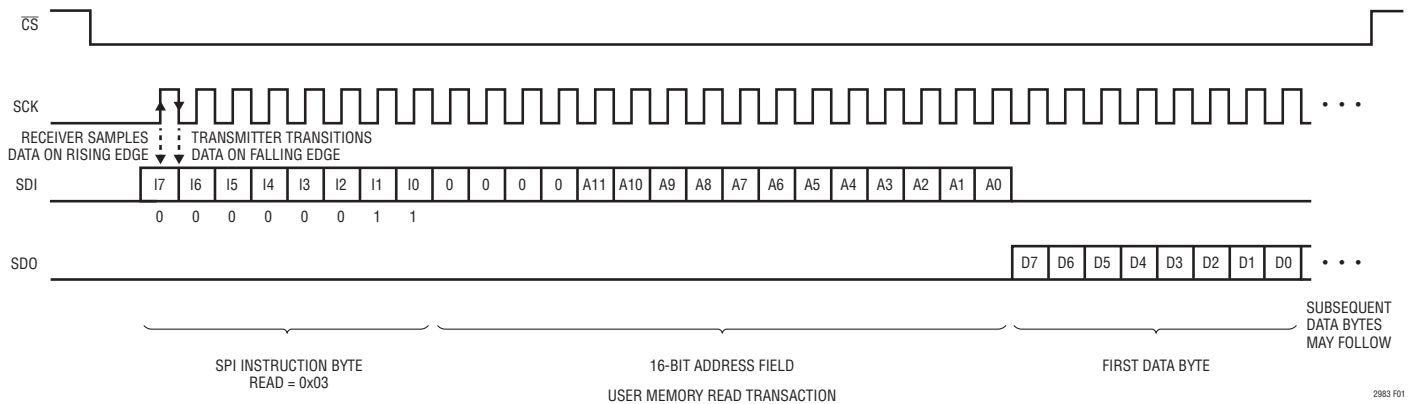

Figure 1. Memory Read Operation

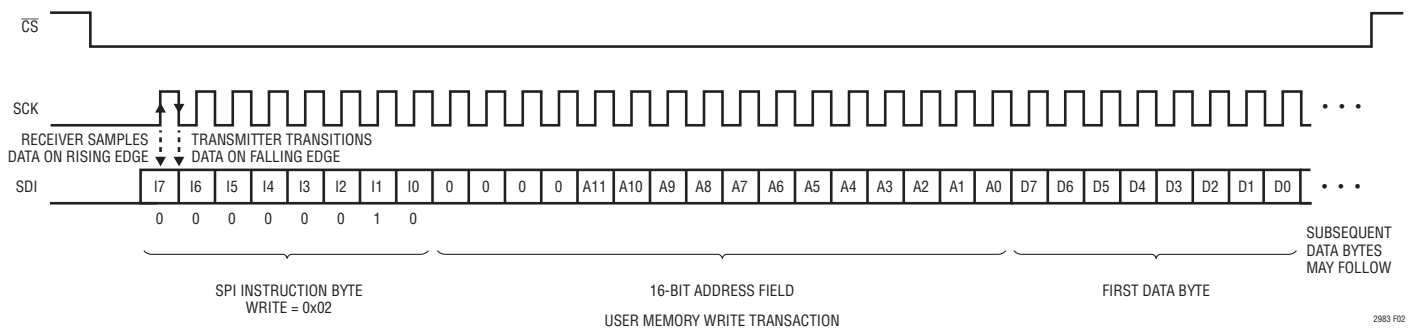

Figure 2. Memory Write Operation

APPLICATIONS INFORMATION

The LTC2983 combines high accuracy with ease of use. The basic operation is simple and is composed of five states (see Figure 3).

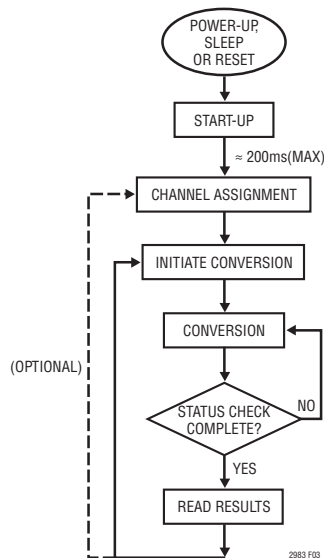

Figure 3. Basic Operation

Conversion States Overview

- 1. Start-Up.** After power is applied to the LTC2983 ($V_{DD} > 2.6V$), there is a 200ms wake up period. During this time, the LDO, charge pump, ADCs, and reference are powered up and the internal RAM is initialized. Once start-up is complete, the INTERRUPT pin goes HIGH and the command status register will return a value of 0x40 (Start bit = 0, Done bit = 1) when read.
- 2. Channel Assignment.** The device automatically enters the channel assignment state after start-up is complete. While in this state, the user writes sensor specific data for each input channel into RAM. The assignment data contains information about the sensor type, pointers to cold junction sensors or sense resistors, and sensor specific parameters.
- 3. Initiate Conversion.** A conversion is initiated by writing a measurement command into RAM memory location 0x000. This command is a pointer to the channel in which the conversion will be performed.
- 4. Conversion.** A new conversion begins automatically following an Initiate Conversion command. In this state, the ADC is running a conversion on the specified channel and associated cold junction or R_{SENSE} channel (if

applicable). The user is locked out of RAM access while in the state (except for reading status location 0x000). The end of conversion is indicated by both the INTERRUPT pin going HIGH and a status register START bit going LOW and DONE bit going HIGH.

- 5. Read Results.** In this state, the user has access to RAM and can read the completed conversion results and fault status bits. It is also possible for the user to modify/append the channel assignment data during the read results state.

Conversion State Details

State 1: Start-Up

The start-up state automatically occurs when power is applied to the LTC2983. If the power drops below a threshold of $\approx 2.6V$ and then returns to the normal operating voltage (2.85V to 5.25V), the LTC2983 resets and enters the power-up state. Note that the LTC2983 also enters the start-up state at the conclusion of the sleep state. The start-up state can also be entered at any time during normal operation by pulsing the RESET pin low.

In the first phase of the start-up state all critical analog circuits are powered up. This includes the LDO, reference, charge pump and ADCs. During this first phase, the command status register will be inaccessible to the user. This phase takes a maximum of 100mS to complete. Once this phase completes, the command status register will be accessible and return a value of 0x80 until the LTC2983 is completely initialized. Once the LTC2983 is initialized and ready to use, the interrupt pin will go high and the command status register will return a read value of 0x40 (Start bit = 0, Done bit = 1). At this point the LTC2983 is fully initialized and is ready to perform a conversion.

State 2: Channel Assignment

The LTC2983 RAM can be programmed with up to 20 sets of 32-bit (4-byte) channel assignment data. These reside sequentially in RAM with a one-to-one correspondence to each of the 20 analog input channels (see Table 3). Channels that are not used should have their channel assignment data set to all zeros (default at START-UP).

The channel assignment data contains all the necessary information associated with the specific sensor tied to that channel (see Table 4). The first five bits determine the sensor type (see Table 5). Associated with each sensor are sensor

2983fc

APPLICATIONS INFORMATION

Table 3. Channel Assignment Memory Map

CHANNEL ASSIGNMENT NUMBER	CONFIGURATION DATA START ADDRESS	CONFIGURATION DATA ADDRESS + 1	CONFIGURATION DATA ADDRESS + 2	CONFIGURATION DATA END ADDRESS + 3	SIZE (BYTES)
CH1	0x200	0x201	0x202	0x203	4
CH2	0x204	0x205	0x206	0x207	4
CH3	0x208	0x209	0x20A	0x20B	4
CH4	0x20C	0x20D	0x20E	0x20F	4
CH5	0x210	0x211	0x212	0x213	4
CH6	0x214	0x215	0x216	0x217	4
CH7	0x218	0x219	0x21A	0x21B	4
CH8	0x21C	0x21D	0x21E	0x21F	4
CH9	0x220	0x221	0x222	0x223	4
CH10	0x224	0x225	0x226	0x227	4
CH11	0x228	0x229	0x22A	0x22B	4
CH12	0x22C	0x22D	0x22E	0x22F	4
CH13	0x230	0x231	0x232	0x233	4
CH14	0x234	0x235	0x236	0x237	4
CH15	0x238	0x239	0x23A	0x23B	4
CH16	0x23C	0x23D	0x23E	0x23F	4
CH17	0x240	0x241	0x242	0x243	4
CH18	0x244	0x245	0x246	0x247	4
CH19	0x248	0x249	0x24A	0x24B	4
CH20	0x24C	0x24D	0x24E	0x24F	4

Table 4. Channel Assignment Data

Channel Assignment Memory Location	SENSOR TYPE		SENSOR SPECIFIC CONFIGURATION																																							
	Configuration Data Start Address					Configuration Data Start Address + 1										Configuration Data Start Address + 2						Configuration Data Start Address + 3																				
	31	30	29	28	27	26	25	24	23	22	21	20	19	18	17	16	15	14	13	12	11	10	9	8	7	6	5	4	3	2	1	0										
Unassigned (Default)	Type = 0					Channel Disabled																																				
Thermocouple	Type = 1 to 9					Cold Junction Channel Assignment [4:0]					SGL=1 DIFF=0	OC Check	OC Current [1:0]			0	0	0	0	0	0	Custom Address [5:0]					Custom Length - 1 [5:0]															
RTD	Type = 10 to 18					R _{SENSE} Channel Assignment [4:0]					2, 3, 4 Wire		Excitation Mode		Excitation Current [3:0]			Curve [1:0]		Custom Address [5:0]					Custom Length - 1 [5:0]																	
Thermistor	Type = 19 to 27					R _{SENSE} Channel Assignment [4:0]					SGL=1 DIFF=0	Excitation Mode		Excitation Current [3:0]			0	0	0	Custom Address [5:0]					Custom Length - 1 [5:0]																	
Diode	Type = 28					SGL=1 DIFF=0					2 to 3 Reading	Avg on	Current [1:0]		Ideality Factor (2, 20) Value from 0 to 4 with 1/1048576 Resolution All Zeros Use Factory Set Default in ROM																											
Sense Resistor	Type = 29					Sense Resistor Value (17, 10) Up to 131,072Ω with 1/1024Ω Resolution																																				
Direct ADC	Type = 30					SGL=1 DIFF=0					Not Used																															
Reserved	Type = 31					Not Used																																				

APPLICATIONS INFORMATION

Table 5. Sensor Type Selection

31	30	29	28	27	SENSOR TYPE
0	0	0	0	0	Unassigned
0	0	0	0	1	Type J Thermocouple
0	0	0	1	0	Type K Thermocouple
0	0	0	1	1	Type E Thermocouple
0	0	1	0	0	Type N Thermocouple
0	0	1	0	1	Type R Thermocouple
0	0	1	1	0	Type S Thermocouple
0	0	1	1	1	Type T Thermocouple
0	1	0	0	0	Type B Thermocouple
0	1	0	0	1	Custom Thermocouple
0	1	0	1	0	RTD PT-10
0	1	0	1	1	RTD PT-50
0	1	1	0	0	RTD PT-100
0	1	1	0	1	RTD PT-200
0	1	1	1	0	RTD PT-500
0	1	1	1	1	RTD PT-1000
1	0	0	0	0	RTD 1000 (0.00375)
1	0	0	0	1	RTD NI-120
1	0	0	1	0	RTD Custom
1	0	0	1	1	Thermistor 44004/44033 2.252k Ω at 25 $^{\circ}$ C
1	0	1	0	0	Thermistor 44005/44030 3k Ω at 25 $^{\circ}$ C
1	0	1	0	1	Thermistor 44007/44034 5k Ω at 25 $^{\circ}$ C
1	0	1	1	0	Thermistor 44006/44031 10k Ω at 25 $^{\circ}$ C
1	0	1	1	1	Thermistor 44008/44032 30k Ω at 25 $^{\circ}$ C
1	1	0	0	0	Thermistor YSI 400 2.252k Ω at 25 $^{\circ}$ C
1	1	0	0	1	Thermistor Spectrum 1003k 1k Ω
1	1	0	1	0	Thermistor Custom Steinhart-Hart
1	1	0	1	1	Thermistor Custom Table
1	1	1	0	0	Diode
1	1	1	0	1	Sense Resistor
1	1	1	1	0	Direct ADC
1	1	1	1	1	Reserved

specific configurations. These include pointers to cold junction or sense resistor channels, pointers to memory locations of custom linearization data, sense resistor values and diode ideality factors. Also included in this data are, if applicable, the excitation current level, single-ended/differential input mode, as well as sensor specific controls. Separate detailed operation sections for thermocouples, RTDs, diodes, thermistors, and sense resistors describe the assignment data associated with each sensor type in more detail. The LTC2983 demonstration

software includes a utility for checking configuration data and generating annotated C-code for programming the channel assignment data.

State 3: Initiate Conversion

Once the channel assignment is complete, the device is ready to begin a conversion. A conversion is initiated by writing Start (B7 = 1) and Done (B6 = 0) followed by the desired input channel (B4 – B0) into RAM memory location 0x000 (see Tables 6 and 7). It is possible to initiate a measurement cycle on multiple channels by setting the channel selection bits (B4 to B0) to 00000; see the Running Conversions Consecutively on Multiple Channels section of the data sheet.

Table 6. Command Status Register

B7	B6	B5	B4	B3	B2	B1	B0	
Start=1	Done=0	0	Channel Selection 1 to 20				Start Conversion	
1	0	0	1	0	1	1	1	Initiate Sleep

Table 7. Input Channel Mapping

B7	B6	B5	B4	B3	B2	B1	B0	CHANNEL SELECTED
1	0	0	0	0	0	0	0	Multiple Channels
1	0	0	0	0	0	0	1	CH1
1	0	0	0	0	0	1	0	CH2
1	0	0	0	0	0	1	1	CH3
1	0	0	0	0	1	0	0	CH4
1	0	0	0	0	1	0	1	CH5
1	0	0	0	0	1	1	0	CH6
1	0	0	0	0	1	1	1	CH7
1	0	0	0	1	0	0	0	CH8
1	0	0	0	1	0	0	1	CH9
1	0	0	0	1	0	1	0	CH10
1	0	0	0	1	0	1	1	CH11
1	0	0	0	1	1	0	0	CH12
1	0	0	0	1	1	0	1	CH13
1	0	0	0	1	1	1	0	CH14
1	0	0	0	1	1	1	1	CH15
1	0	0	1	0	0	0	0	CH16
1	0	0	1	0	0	0	1	CH17
1	0	0	1	0	0	1	0	CH18
1	0	0	1	0	0	1	1	CH19
1	0	0	1	0	1	0	0	CH20
1	0	0	1	0	1	1	1	Sleep
All Other Combinations								Reserved

APPLICATIONS INFORMATION

Bits B4 to B0 determine which input channel the conversion is performed upon and are simply the binary equivalent of the channel number (see Table 7).

Bit B5 should be set to 0.

Bits B7 and B6 serve as start/done bits. In order to start a conversion, these bits must be set to “10” (B7=1 and B6=0). When the conversion begins, the INTERRUPT pin goes LOW. Once the conversion is complete, bits B7 and B6 will toggle to “01” (B7=0 and B6=1) (Address = 0x000) and the INTERRUPT pin will go HIGH, indicating the conversion is complete and the result is available.

State 4: Conversion

The measurement cycle starts after the initiate conversion command is written into RAM location 0x000 (Table 6). The LTC2983 simultaneously measures the selected input sensor, sense resistors (RTDs and thermistors), and cold junction temperatures if applicable (thermocouples).

Once the conversion is started, the user is locked out of the RAM, with the exception of reading status data stored in RAM memory location 0x000.

Once the conversion is started the INTERRUPT pin goes low. Depending on the sensor configuration, two or three 82ms cycles are required per temperature result. These correspond to conversion rates of 167ms and 251ms, respectively. Details describing these modes are described in the 2- and 3-cycle Conversion Modes section of the data sheet.

The end of conversion can be monitored either through the interrupt pin (LOW to HIGH transition), or by reading the command status register in RAM memory location 0x000 (start bit, B7, toggles from 1 to 0 and DONE bit, B6, toggles from 0 to 1).

State 5: Read Results

Once the conversion is complete, the conversion results can be read from RAM memory locations corresponding to the input channel (see Table 8).

The conversion result is 32 bits long and contains both the sensor temperature (D23 to D0) and sensor fault data (D31 to D24) (see Tables 9A and 9B).

Table 8. Conversion Result Memory Map

CONVERSION CHANNEL	START ADDRESS	END ADDRESS	SIZE (BYTES)
CH1	0x010	0x013	4
CH2	0x014	0x017	4
CH3	0x018	0x01B	4
CH4	0x01C	0x01F	4
CH5	0x020	0x023	4
CH6	0x024	0x027	4
CH7	0x028	0x02B	4
CH8	0x02C	0x02F	4
CH9	0x030	0x033	4
CH10	0x034	0x037	4
CH11	0x038	0x03B	4
CH12	0x03C	0x03F	4
CH13	0x040	0x043	4
CH14	0x044	0x047	4
CH15	0x048	0x04B	4
CH16	0x04C	0x04F	4
CH17	0x050	0x053	4
CH18	0x054	0x057	4
CH19	0x058	0x05B	4
CH20	0x05C	0x05F	4

The result is reported in °C for all temperature sensors with a range of –273.16°C to 8192°C and 1/1024°C resolution or in °F with a range of –459.67°F to 8192°F with 1/1024°F resolution. Included with the conversion result are seven sensor fault bits and a valid bit. These bits are set to a 1 if there was a problem associated with the corresponding conversion result (see Table 10). Two types of errors are reported: hard errors and soft errors. Hard errors indicate the reading is invalid and the resulting temperature reported is –999°C or °F. Soft errors indicate operation beyond the normal temperature range of the sensor or the input range of the ADC. In this case, the calculated temperature is reported but the accuracy may be compromised. Details relating to each fault type are sensor specific and are described in detail in the sensor specific sections of this data sheet. Bit D24 is the valid bit and will be set to a 1 for valid data.

Once the data read is complete, the device is ready for a new initiate conversion command. In cases where new channel configuration data is required, the user has access to the RAM in order to modify existing channel assignment data.

APPLICATIONS INFORMATION

Table 9A. Example Data Output Words (°C)

	START ADDRESS								START ADDRESS + 1								START ADDRESS + 2								START ADDRESS + 3 (END ADDRESS)														
	D31	D30	D29	D28	D27	D26	D25	D24	D23	D22	D21	D20	D19	D18	D17	D16	D15	D14	D13	D12	D11	D10	D9	D8	D7	D6	D5	D4	D3	D2	D1	D0							
	Fault Data								SIGN MSB																								LSB						
Temperature	Sensor Hard Fault	ADC Hard Fault	CJ Hard Fault	CJ Soft Fault	Sensor Over Range Fault	Sensor Under Range Fault	ADC Out of Range Fault	Valid If 1	4096°C								1°C								1/1024°C														
8191.999°C								1	0	1	1	1	1	1	1	1	1	1	1	1	1	1	1	1	1	1	1	1	1	1	1								
1024°C								1	0	0	0	0	1	0	0	0	0	0	0	0	0	0	0	0	0	0	0	0	0	0	0	0							
1°C								1	0	0	0	0	0	0	0	0	0	0	0	0	0	0	1	0	0	0	0	0	0	0	0	0							
1/1024°C								1	0	0	0	0	0	0	0	0	0	0	0	0	0	0	0	0	0	0	0	0	0	0	0	1							
0°C								1	0	0	0	0	0	0	0	0	0	0	0	0	0	0	0	0	0	0	0	0	0	0	0	0							
-1/1024°C								1	1	1	1	1	1	1	1	1	1	1	1	1	1	1	1	1	1	1	1	1	1	1	1	1							
-1°C								1	1	1	1	1	1	1	1	1	1	1	1	1	1	1	0	0	0	0	0	0	0	0	0	0							
-273.15°C								1	1	1	1	1	1	0	1	1	1	0	1	1	1	0	1	1	0	1	1	0	0	1	1	1							

Table 9B. Example Data Output Words (°F)

	START ADDRESS								START ADDRESS + 1								START ADDRESS + 2								START ADDRESS + 3 (END ADDRESS)														
	D31	D30	D29	D28	D27	D26	D25	D24	D23	D22	D21	D20	D19	D18	D17	D16	D15	D14	D13	D12	D11	D10	D9	D8	D7	D6	D5	D4	D3	D2	D1	D0							
	Fault Data								SIGN MSB																								LSB						
Temperature	Sensor Hard Fault	ADC Hard Fault	CJ Hard Fault	CJ Soft Fault	Sensor Over Range Fault	Sensor Under Range Fault	ADC Out of Range Fault	Valid If 1	4096°F								1°F								1/1024°F														
8191.999°F								1	0	1	1	1	1	1	1	1	1	1	1	1	1	1	1	1	1	1	1	1	1	1	1								
1024°F								1	0	0	0	0	1	0	0	0	0	0	0	0	0	0	0	0	0	0	0	0	0	0	0	0							
1°F								1	0	0	0	0	0	0	0	0	0	0	0	0	0	0	1	0	0	0	0	0	0	0	0	0							
1/1024°F								1	0	0	0	0	0	0	0	0	0	0	0	0	0	0	0	0	0	0	0	0	0	0	0	1							
0°F								1	0	0	0	0	0	0	0	0	0	0	0	0	0	0	0	0	0	0	0	0	0	0	0	0							
-1/1024°F								1	1	1	1	1	1	1	1	1	1	1	1	1	1	1	1	1	1	1	1	1	1	1	1	1							
-1°F								1	1	1	1	1	1	1	1	1	1	1	1	1	1	1	0	0	0	0	0	0	0	0	0	0							
-459.67°F								1	1	1	1	1	1	0	0	0	1	1	0	1	0	0	0	1	0	1	0	0	1	0	1	0							

Table 10. Sensor Fault Reporting

BIT	FAULT	ERROR TYPE	DESCRIPTION	OUTPUT RESULT
D31	Sensor Hard Fault	Hard	Bad Sensor Reading	-999°C or °F
D30	Hard ADC-Out-of-Range	Hard	Bad ADC Reading (Could Be Large External Noise Event)	-999°C or °F
D29	CJ Hard Fault	Hard	Cold Junction Sensor Has a Hard Fault Error	-999°C or °F
D28	CJ Soft Fault	Soft	Cold Junction Sensor Result Is Beyond Normal Range	Suspect Reading
D27	Sensor Over Range	Soft	Sensor Reading Is Above Normal Range	Suspect Reading
D26	Sensor Under Range	Soft	Sensor Reading Is Below Normal Range	Suspect Reading
D25	ADC Out-of-Range	Soft	ADC Absolute Input Voltage Is Beyond $\pm 1.125 \cdot V_{REF}/2$	Suspect Reading
D24	Valid	NA	Result Valid (Should Be 1) Discard Results if 0	Suspect Reading

2983fc

APPLICATIONS INFORMATION

THERMOCOUPLE MEASUREMENTS

Table 11. Thermocouple Channel Assignment Word

	(1) THERMOCOUPLE TYPE					(2) COLD JUNCTION CHANNEL POINTER					(3) SENSOR CONFIGURATION				(4) CUSTOM THERMOCOUPLE DATA POINTER																	
	TABLES 4, 12					TABLE 13					TABLE 14				TABLES 67 TO 69																	
Measurement Type	31	30	29	28	27	26	25	24	23	22	21	20	19	18	17	16	15	14	13	12	11	10	9	8	7	6	5	4	3	2	1	0
Thermocouple	Types 1 to 9					Cold Junction Channel Assignment [4:0]					SGL=1 DIFF=0	OC Check	OC Current [1:0]		0	0	0	0	0	0	Custom Address [5:0]					Custom Length –1 [5:0]						

Channel Assignment – Thermocouples

For each thermocouple tied to the LTC2983, a 32-bit channel assignment word is programmed into a memory location corresponding to the channel the sensor is tied to (see Table 11). This word includes (1) thermocouple type, (2) cold junction channel pointer, (3) sensor configuration, and (4) custom thermocouple data pointer.

(1) Thermocouple Type

The thermocouple type is determined by the first five input bits B31 to B27 as shown in Table 12. Standard NIST coefficients for types J,K,E,N,R,S,T and B thermocouples are stored in the device ROM. If custom thermocouples are used, the custom thermocouple sensor type can be selected. In this case, user-specific data can be stored in the on-chip RAM starting at the address defined in the custom thermocouple data pointer.

(2) Cold Junction Channel Pointer

The cold junction compensation can be a diode, RTD, or thermistor. The cold junction channel pointer tells the LTC2983 which channel (1 to 20) the cold junction

sensor is assigned to (see Table 13). When a conversion is performed on a channel tied to a thermocouple, the cold junction sensor is simultaneously and automatically measured. The final output data uses the embedded coefficients stored in ROM to automatically compensate the cold junction temperature and output the thermocouple sensor temperature.

Table 13. Cold Junction Channel Pointer

(2) COLD JUNCTION CHANNEL POINTER					COLD JUNCTION CHANNEL
B26	B25	B24	B23	B22	
0	0	0	0	0	No Cold Junction Compensation, 0°C Used for Calculations
0	0	0	0	1	CH1
0	0	0	1	0	CH2
0	0	0	1	1	CH3
0	0	1	0	0	CH4
0	0	1	0	1	CH5
0	0	1	1	0	CH6
0	0	1	1	1	CH7
0	1	0	0	0	CH8
0	1	0	0	1	CH9
0	1	0	1	0	CH10
0	1	0	1	1	CH11
0	1	1	0	0	CH12
0	1	1	0	1	CH13
0	1	1	1	0	CH14
0	1	1	1	1	CH15
1	0	0	0	0	CH16
1	0	0	0	1	CH17
1	0	0	1	0	CH18
1	0	0	1	1	CH19
1	0	1	0	0	CH20
All Other Combinations					Invalid

Table 12. Thermocouple Type

(1) THERMOCOUPLE TYPE					THERMOCOUPLE TYPES
B31	B30	B29	B28	B27	
0	0	0	0	1	Type J Thermocouple
0	0	0	1	0	Type K Thermocouple
0	0	0	1	1	Type E Thermocouple
0	0	1	0	0	Type N Thermocouple
0	0	1	0	1	Type R Thermocouple
0	0	1	1	0	Type S Thermocouple
0	0	1	1	1	Type T Thermocouple
0	1	0	0	0	Type B Thermocouple
0	1	0	0	1	Custom Thermocouple

APPLICATIONS INFORMATION

(3) Sensor Configuration

The sensor configuration field (see Table 14) is used to select single-ended (B21=1) or differential (B21=0) input and allows selection of open circuit current if internal open-circuit detect is enabled (bit B20). Single-ended readings are measured relative to the COM pin and differential are measured between the selected CH_{TC} and adjacent CH_{TC-1} (see Figure 4). If open-circuit detection is enabled, B20=1, then the user can select the pulsed current value applied during open-circuit detect using bits B18 and B19. The user determines the value of the open circuit current based on the size of the external protection resistor and filter capacitor (typically $10\mu A$). This network needs to settle within 50ms to $1\mu V$ or less. The duration of the current pulse is approximately 8ms and occurs 50ms before the normal conversion cycle.

Thermocouple channel assignments follow the general convention shown in Figure 4. The thermocouple positive terminal ties to CH_{TC} (where TC is the selected channel number) for both the single-ended and differential modes of operation. For single-ended measurements the thermocouple negative terminal and the COM pin are grounded. The thermocouple negative terminal is tied to CH_{TC-1} for differential measurements. This node can either be grounded or tied to a bias voltage.

(4) Custom Thermocouple Data Pointer

See Custom Thermocouples section near the end of this data sheet for more information.

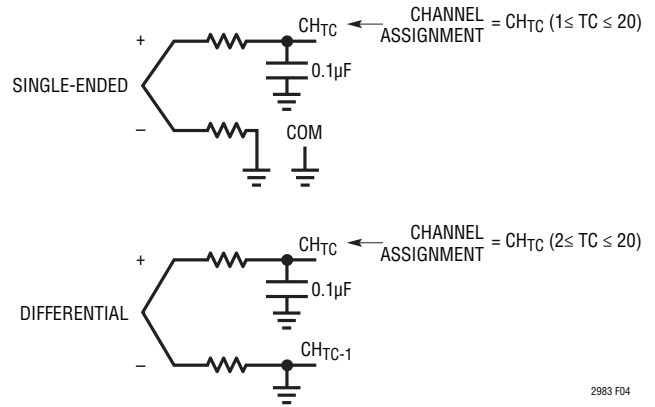

Figure 4. Thermocouple Channel Assignment Convention

Table 14. Sensor Configuration

(3) SENSOR CONFIGURATION				SINGLE-ENDED/ DIFFERENTIAL	OPEN-CIRCUIT CURRENT
SGL	OC CHECK	OC CURRENT			
B21	B20	B19	B18		
0	0	X	X	Differential	External
0	1	0	0	Differential	$10\mu A$
0	1	0	1	Differential	$100\mu A$
0	1	1	0	Differential	$500\mu A$
0	1	1	1	Differential	1mA
1	0	X	X	Single-Ended	External
1	1	0	0	Single-Ended	$10\mu A$
1	1	0	1	Single-Ended	$100\mu A$
1	1	1	0	Single-Ended	$500\mu A$
1	1	1	1	Single-Ended	1mA

APPLICATIONS INFORMATION

Fault Reporting – Thermocouple

Each sensor type has a unique fault reporting mechanism indicated in the upper byte of the data output word. Table 15 shows faults reported in the measurement of thermocouples.

Bit D31 indicates the thermocouple sensor is open (broken or not plugged in), the cold junction sensor has a hard fault, or the ADC is out of range. This is indicated by a reading well beyond the normal operating range. Bit D30 indicates a bad ADC reading. This can be a result of either a broken (open) sensor or an excessive noise event (ESD or static discharge into the sensor path). Either of these are a hard error and -999°C or $^{\circ}\text{F}$ is reported. In the case of an excessive noise event, the device should recover and the following conversions will be valid if the noise event was a random, infrequent event. Bit D29 indicates a hard fault occurred at the cold junction sensor and -999°C or $^{\circ}\text{F}$ is reported. Refer to the specific sensor (diode, thermistor, or RTD) used for cold junction compensation. Bit D28 indicates a soft fault occurred at the cold junction

sensor. A valid temperature is reported, but the accuracy may be compromised since the cold junction sensor is operating outside its normal temperature range. Bits D27 and D26 indicate over or under temperature limits have been exceeded for specific thermocouple types, as defined in Table 16. Bit D25 indicates the absolute voltage measured by the ADC is beyond its normal operating range. This fault reflects a reading that is well beyond the normal range of a thermocouple.

Table 16. Thermocouple Temperature Limits

THERMOCOUPLE TYPE	LOW TEMP LIMIT $^{\circ}\text{C}$	HIGH TEMP LIMIT $^{\circ}\text{C}$
J-Type	-210	1200
K-Type	-265	1372
E-Type	-265	1000
N-Type	-265	1300
R-type	-50	1768
S-Type	-50	1768
T-Type	-265	400
B-Type	40	1820
Custom	Lowest Table Entry	Highest Table Entry

Table 15. Thermocouple Fault Reporting

BIT	FAULT	ERROR TYPE	DESCRIPTION	OUTPUT RESULT
D31	Sensor Hard Fault	Hard	Open Circuit or Hard ADC or Hard CJ	-999°C or $^{\circ}\text{F}$
D30	Hard ADC-Out-of-Range	Hard	Bad ADC Reading (Could Be Large External Noise Event)	-999°C or $^{\circ}\text{F}$
D29	CJ Hard Fault	Hard	Cold Junction Sensor Has a Hard Fault Error	-999°C or $^{\circ}\text{F}$
D28	CJ Soft Fault	Soft	Cold Junction Sensor Result Is Beyond Normal Range	Suspect Reading
D27	Sensor Over Range	Soft	Thermocouple Reading Greater Than High Limit	Suspect Reading
D26	Sensor Under Range	Soft	Thermocouple Reading Less Than Low Limit	Suspect Reading
D25	ADC Out-of-Range	Soft	ADC Absolute Input Voltage Is Beyond $\pm 1.125 \cdot V_{\text{REF}}/2$	Suspect Reading
D24	Valid	NA	Result Valid (Should Be 1) Discard Results if 0	Valid Reading

APPLICATIONS INFORMATION

DIODE MEASUREMENTS

Table 17. Diode Channel Assignment Word

	(1) SENSOR TYPE					(2) SENSOR CONFIGURATION			(3) EXCITATION CURRENT		(4) DIODE IDEALITY FACTOR VALUE																					
	TABLE 18								TABLE 19		TABLE 20																					
Measurement Class	31	30	29	28	27	26	25	24	23	22	21	20	19	18	17	16	15	14	13	12	11	10	9	8	7	6	5	4	3	2	1	0
Diode	Type = 28					SGL=1 DIFF=0	2 or 3 Readings	Avg on	Current [1:0]		Non-Ideality Factor (2, 20) Value from 0 to 4 with 1/1048576 Resolution All Zeros Uses a Factory Set Default of 1.003																					

Channel Assignment – Diode

For each diode tied to the LTC2983, a 32-bit channel assignment word is programmed into a memory location corresponding to the channel the sensor is tied to (see Table 17). This word includes (1) diode sensor selection, (2) sensor configuration, (3) excitation current, and (4) diode ideality factor.

1) Sensor Type

The diode is selected by the first five input bits B31 to B27 (see Table 18).

Table 18. Diode Sensor Selection

(1) SENSOR TYPE					SENSOR TYPE
B31	B30	B29	B28	B27	
1	1	1	0	0	Diode

(2) Sensor Configuration

The sensor configuration field (bits B26 to B24) is used to define various diode measurement properties. Configuration bit B26 is set high for single-ended (measurement relative to COM) and low for differential.

Bit B25 sets the measurement algorithm. If B25 is low, two conversion cycles (one at **1I** and one at **8I** current excitation) are used to measure the diode. This is used in applications where parasitic resistance between the LTC2983 and the diode is small. Parasitic resistance effects can be removed by setting bit B25 high, enabling three conversion cycles (one at **1I**, one at **4I** and one at **8I**).

Table 20. Programming Diode Ideality Factor

	(4) DIODE IDEALITY FACTOR VALUE																					
	B21	B20	B19	B18	B17	B16	B15	B14	B13	B12	B11	B10	B9	B8	B7	B6	B5	B4	B3	B2	B1	B0
Example η	2 ¹	2 ⁰	2 ⁻¹	2 ⁻²	2 ⁻³	2 ⁻⁴	2 ⁻⁵	2 ⁻⁶	2 ⁻⁷	2 ⁻⁸	2 ⁻⁹	2 ⁻¹⁰	2 ⁻¹¹	2 ⁻¹²	2 ⁻¹³	2 ⁻¹⁴	2 ⁻¹⁵	2 ⁻¹⁶	2 ⁻¹⁷	2 ⁻¹⁸	2 ⁻¹⁹	2 ⁻²⁰
1.25	0	1	0	1	0	0	0	0	0	0	0	0	0	0	0	0	0	0	0	0	0	0
1.003 (Default)	0	0	0	0	0	0	0	0	0	0	0	0	0	0	0	0	0	0	0	0	0	0
1.006	0	1	0	0	0	0	0	0	0	1	1	0	0	0	1	0	0	1	0	0	1	1

Bit B24 enables a running average of the diode temperature reading. This reduces the noise when the diode is used as a cold junction temperature element on an isothermal block where temperatures change slowly.

The algorithm used for diode averaging is a simple recursive running average. The new value is equal to the average of the current reading plus the previous value.

$$NEW\ VALUE = \frac{CURRENT\ READING}{2} + \frac{PREVIOUS\ VALUE}{2}$$

If the current reading is 2°C above or below the previous value, the new value is reset to the current reading.

(3) Excitation Current

The next field in the channel assignment word (B23 to B22) controls the magnitude of the excitation current applied to the diode (see Table 19). In the two conversion cycle mode, the device performs the first conversion at a current equal to 8x the excitation current **1I**. The second conversion occurs at **1I**. Alternatively, in the three conversion cycle mode the first conversion excitation current is **8I**, the second is **4I** and the 3rd is **1I**.

Table 19. Diode Excitation Current Selection

(3) EXCITATION CURRENT		1I	4I	8I
B23	B22			
0	0	10µA	40µA	80µA
0	1	20µA	80µA	160µA
1	0	40µA	160µA	320µA
1	1	80µA	320µA	640µA

APPLICATIONS INFORMATION

(4) Diode Ideality Factor

The last field in the channel assignment word (B21 to B0) sets the diode ideality factor within the range 0 to 4 with $1/1048576$ (2^{-20}) resolution. The top two bits (B21 to B20) are the integer part and bits B19 to B0 are the fractional part of the ideality factor (see Table 20).

Diode channel assignments follow the general convention shown in Figure 5. The anode ties to CH_D (where D is the selected channel number) for both the single-ended and differential modes of operation, and the cathode is grounded. For differential diode measurements, the cathode is also tied to CH_{D-1} .

Fault Reporting - Diode

Each sensor type has unique fault reporting mechanism indicated in the upper byte of the data output word. Table 21 shows faults reported in the measurement of diodes.

Bit D31 indicates the diode is open, shorted, not plugged in, wired backwards, or the ADC reading is bad. Any of these are hard faults and -999°C or $^{\circ}\text{F}$ is reported. Bit D30 indicates a bad ADC reading. This can be a result of either a broken (open) sensor or an excessive noise event (ESD or static discharge into the sensor path). This is a

hard error and -999°C or $^{\circ}\text{F}$ is reported. In the case of an excessive noise event, the device should recover and the following conversions will be valid if the noise event was a random, infrequent event. Bits D29 and D28 are not used for diodes. Bits D27 and D26 indicate over or under temperature limits (defined as $T > 130^{\circ}\text{C}$ or $T < -60^{\circ}\text{C}$). The calculated temperature is reported, but the accuracy may be compromised. Bit D25 indicates the absolute voltage measured by the ADC is beyond its normal operating range. If a diode is used as the cold junction element, any hard or soft error is flagged in the corresponding thermocouple result (bits D28 and D29 in Table 15).

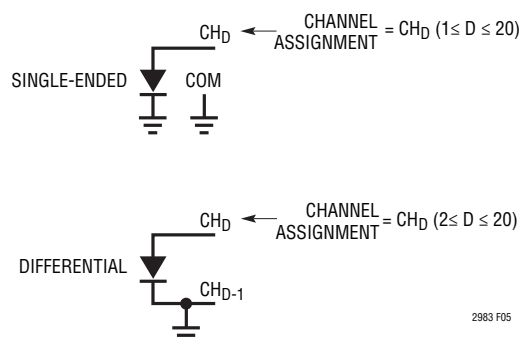

Figure 5. Diode Channel Assignment Convention

Table 21. Diode Fault Reporting

BIT	FAULT	ERROR TYPE	DESCRIPTION	OUTPUT RESULT
D31	Sensor Hard Fault	Hard	Open, Short, Reversed, or Hard ADC	-999°C or $^{\circ}\text{F}$
D30	Hard ADC-Out-of-Range	Hard	Bad ADC Reading (Could Be Large External Noise Event)	-999°C or $^{\circ}\text{F}$
D29	Not Used for Diodes	N/A	Always 0	
D28	Not Used for Diodes	N/A	Always 0	
D27	Sensor Over Range	Soft	$T > 130^{\circ}\text{C}$	Suspect Reading
D26	Sensor Under Range	Soft	$T < -60^{\circ}\text{C}$	Suspect Reading
D25	ADC Out-of-Range	Soft	ADC Absolute Input Voltage Is Beyond $\pm 1.125 \cdot V_{\text{REF}}/2$	Suspect Reading
D24	Valid	NA	Result Valid (Should Be 1) Discard Results if 0	Valid Reading

APPLICATIONS INFORMATION

Example: Single-Ended Type K and Differential Type T Thermocouples with Shared Diode Cold Junction Compensation

Figure 6 shows a typical temperature measurement system where two thermocouples share a single cold junction diode. In this example, a Type K thermocouple is tied to CH1 and a Type T thermocouple is tied to CH3 and CH4. They both share a single cold junction diode with ideality factor of $\eta=1.003$ tied to CH2. Channel assignment data for both thermocouples and the diode are

shown in Tables 22 to 24. Thermocouple #1 (Type K) sensor type and configuration data are assigned to CH1. 32-bits of binary configuration data are mapped directly into memory locations 0x200 to 0x203 (see Table 22). The cold junction diode sensor type and configuration data are assigned to CH2. 32-bits of binary configuration data are mapped directly into memory locations 0x204 to 0x207 (see Table 23). Thermocouple #2 (Type T) sensor type and configuration data are assigned to CH4. 32-bits of binary configuration data are mapped directly

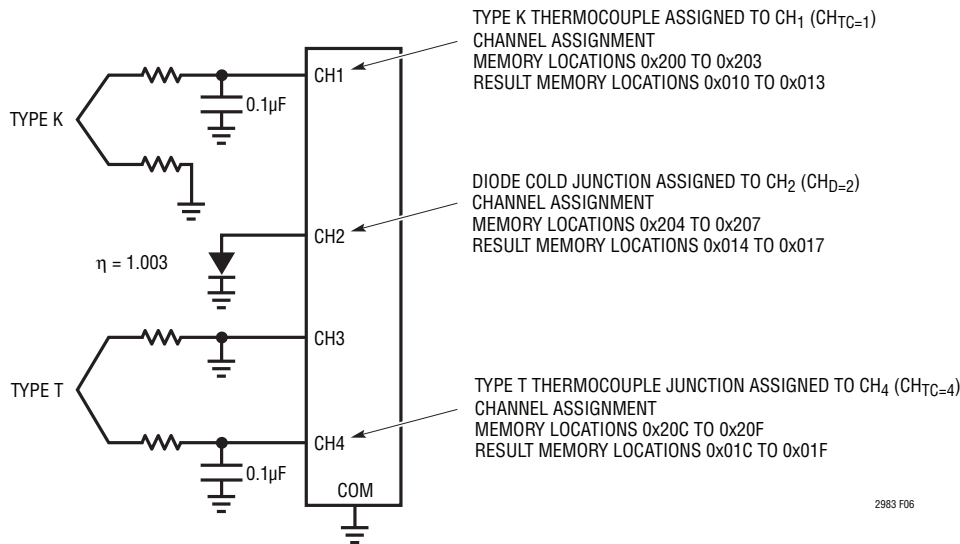

Figure 6. Dual Thermocouple with Diode Cold Junction Example

APPLICATIONS INFORMATION

into memory locations 0x20C to 0x20F (see Table 24). A conversion is initiated on CH1 by writing 10000001 into memory location 0x000. Both the Type K thermocouple and the diode are measured simultaneously. The LTC2983 calculates the cold junction compensation and determines the temperature of the Type K thermocouple. Once the

conversion is complete, the INTERRUPT pin goes HIGH and memory location 0x000 becomes 01000001. Similarly, a conversion can be initiated on CH4 by writing 10000100 into memory location 0x000. The results (in °C) can be read from memory locations 0x010 to 0x013 for CH1 and 0x01C to 0x01F for CH4.

Table 22. Thermocouple #1 Channel Assignment (Type K, Cold Junction CH₂, Single-Ended, 10μA Open-Circuit Detect)

CONFIGURATION FIELD	DESCRIPTION	# BITS	BINARY DATA	MEMORY ADDRESS 0x200	MEMORY ADDRESS 0x201	MEMORY ADDRESS 0x202	MEMORY ADDRESS 0x203
(1) Thermocouple Type	Type K	5	00010	0 0 0 1 0			
(2) Cold Junction Channel Pointer	CH ₂	5	00010		0 0 0 1 0		
(3) Sensor Configuration	Single-Ended, 10μA Open-Circuit	4	1100		1 1 0 0		
Not Used	Set These Bits to 0	6	000000			0 0 0 0 0 0	
(4) Custom Thermocouple Data Pointer	Not Custom	12	000000000000				0 0 0 0 0 0 0 0 0 0 0 0

Table 23. Diode Channel Assignment (Single-Ended 3-Reading, Averaging On, 20μA/80μA Excitation, Ideality Factor = 1.003)

CONFIGURATION FIELD	DESCRIPTION	# BITS	BINARY DATA	MEMORY ADDRESS 0x204	MEMORY ADDRESS 0x205	MEMORY ADDRESS 0x206	MEMORY ADDRESS 0x207
(1) Sensor Type	Diode	5	11100	1 1 1 0 0			
(2) Sensor Configuration	Single-Ended, 3-Reading, Average On	3	111		1 1 1		
(3) Excitation Current	20μA, 80μA, 160μA	2	01		0 1		
(4) Ideality Factor	1.003	22	010000000110001001001			0 1 0 0 0 0 0 0 0 0 0 1 1 0 0 0 1 0 0 1 0 0 1	

Table 24. Thermocouple #2 Channel Assignment (Type T, Cold Junction CH₂, Differential, 100μA Open-Circuit Detect)

CONFIGURATION FIELD	DESCRIPTION	# BITS	BINARY DATA	MEMORY ADDRESS 0x20C	MEMORY ADDRESS 0x20D	MEMORY ADDRESS 0x20E	MEMORY ADDRESS 0x20F
(1) Thermocouple Type	Type T	5	00111	0 0 1 1 1			
(2) Cold Junction Channel Pointer	CH ₂	5	00010		0 0 0 1 0		
(3) Sensor Configuration	Differential, 100μA Open-Circuit Current	4	0101		0 1 0 1		
Not Used	Set These Bits to 0	6	000000			0 0 0 0 0 0	
(4) Custom Thermocouple Data Pointer	Not Custom	12	000000000000				0 0 0 0 0 0 0 0 0 0 0 0

APPLICATIONS INFORMATION

RTD MEASUREMENTS

Table 25. RTD Channel Assignment Word

	(1) RTD TYPE					(2) SENSE RESISTOR CHANNEL POINTER					(3) SENSOR CONFIGURATION				(4) EXCITATION CURRENT				(5) RTD CURVE		(6) CUSTOM RTD DATA POINTER											
	TABLE 26					TABLE 27					TABLE 28				TABLE 29				TABLE 30		TABLES 72 TO 74											
Measurement Class	31	30	29	28	27	26	25	24	23	22	21	20	19	18	17	16	15	14	13	12	11	10	9	8	7	6	5	4	3	2	1	0
RTD	Type = 10 to 18					R _{SENSE} Channel Assignment [4:0]					2, 3, 4 Wire				Excitation Mode				Excitation Current [3:0]		Curve [1:0]		Custom Address [5:0]					Custom Length – 1 [5:0]				

Channel Assignment – RTD

For each RTD tied to the LTC2983, a 32-bit channel assignment word is programmed into a memory location corresponding to the channel the sensor is tied to (see Table 25). This word includes (1) RTD type, (2) sense resistor channel pointer, (3) sensor configuration, (4) excitation current, (5) RTD curve, and (6) custom RTD data pointer.

(1) RTD Type

The RTD type is determined by the first five input bits B31 to B27 as shown in Table 26. Linearization coefficients for RTD types PT-10, PT-50, PT-100, PT-200, PT-500, PT-1000, and NI-120 with selectable common curves ($\alpha = 0.003850$, $\alpha = 0.003911$, $\alpha = 0.003916$, and $\alpha = 0.003926$) are built into the device. If custom RTDs are used, RTD Custom can be selected. In this case, user specific data can be stored in the on-chip RAM starting at the address defined by the custom RTD data pointers.

Table 26. RTD Type

(1) RTD TYPE					RTD TYPE
B31	B30	B29	B28	B27	
0	1	0	1	0	RTD PT-10
0	1	0	1	1	RTD PT-50
0	1	1	0	0	RTD PT-100
0	1	1	0	1	RTD PT-200
0	1	1	1	0	RTD PT-500
0	1	1	1	1	RTD PT-1000
1	0	0	0	0	RTD 1000 ($\alpha=0.00375$)
1	0	0	0	1	RTD NI-120
1	0	0	1	0	RTD Custom

(2) Sense Resistor Channel Pointer

RTD measurements are performed ratiometrically relative to a known R_{SENSE} resistor. The sense resistor channel pointer field indicates the differential channel the sense resistor is tied to for the RTD (see Table 27). Sense resistors are always measured differentially.

Table 27. Sense Resistor Channel Pointer

(2) SENSE RESISTOR CHANNEL POINTER					SENSE RESISTOR CHANNEL
B26	B25	B24	B23	B22	
0	0	0	0	0	Invalid
0	0	0	0	1	Invalid
0	0	0	1	0	CH2-CH1
0	0	0	1	1	CH3-CH2
0	0	1	0	0	CH4-CH3
0	0	1	0	1	CH5-CH4
0	0	1	1	0	CH6-CH5
0	0	1	1	1	CH7-CH6
0	1	0	0	0	CH8-CH7
0	1	0	0	1	CH9-CH8
0	1	0	1	0	CH10-CH9
0	1	0	1	1	CH11-CH10
0	1	1	0	0	CH12-CH11
0	1	1	0	1	CH13-CH12
0	1	1	1	0	CH14-CH13
0	1	1	1	1	CH15-CH14
1	0	0	0	0	CH16-CH15
1	0	0	0	1	CH17-CH16
1	0	0	1	0	CH18-CH17
1	0	0	1	1	CH19-CH18
1	0	1	0	0	CH20-CH19
All Other Combinations					Invalid

APPLICATIONS INFORMATION

(3) Sensor Configuration

The sensor configuration field is used to define various RTD properties. Configuration bits B20 and B21 determine if the RTD is a 2, 3, or 4 wire type (see Table 28).

The simplest configuration is the 2-wire configuration. While this setup is simple, parasitic errors due to IR drops in the leads result in systematic temperature errors. The 3-wire configuration cancels RTD lead resistance errors (if the lines are equal resistance) by applying two matched current sources to the RTD, one per lead. Mismatches in the two current sources are removed through transparent background calibration. 4-wire RTDs remove unbalanced RTD lead resistance by measuring directly across the

sensor using a high impedance Kelvin sensing. 4-wire measurements with Kelvin R_{SENSE} are useful in applications where sense resistor wiring parasitics can lead to errors; this is especially useful for low resistance PT-10 type RTDs. In this case, both the RTD and sense resistor have Kelvin sensing connections.

The next sensor configuration bits (B18 and B19) determine the excitation current mode. These bits are used to enable R_{SENSE} sharing, where one sense resistor is used for multiple 2-, 3-, and/or 4-wire RTDs. In this case, the RTD ground connection is internal and each RTD points to the same R_{SENSE} channel.

Table 28. RTD Sensor Configuration Selection

(3) SENSE CONFIGURATION				MEASUREMENT MODE					BENEFITS			
NUMBER OF WIRES		EXCITATION MODE		NUMBER OF WIRES	GROUND CONNECTION	CURRENT SOURCE ROTATION	SENSE RESISTOR SHARING	RTDs POSSIBLE PER DEVICE	CANCELS RTD MATCHED LEAD RESISTANCE	CANCELS RTD MISMATCH LEAD RESISTANCE	CANCELS PARASITIC THERMOCOUPLE EFFECTS	CANCELS R_{SENSE} LEAD RESISTANCE
B21	B20	B19	B18									
0	0	0	0	2-Wire	External	No	No	5				
0	0	0	1	2-Wire	Internal	No	Yes	9				
0	1	0	0	3-Wire	External	No	No	5	•			
0	1	0	1	3-Wire	Internal	No	Yes	9	•			
0	1	1	X	Reserved								
1	0	0	0	4-Wire	External	No	No	4	•	•		
1	0	0	1	4-Wire	Internal	No	Yes	6	•	•		
1	0	1	0	4-Wire	Internal	Yes	Yes	6	•	•	•	
1	0	1	1	Reserved								
1	1	0	0	4-Wire, Kelvin R_{SENSE}	External	No	No	4	•	•		•
1	1	0	1	4-Wire, Kelvin R_{SENSE}	Internal	No	Yes	5	•	•		•
1	1	1	0	4-Wire, Kelvin R_{SENSE}	Internal	Yes	Yes	5	•	•	•	•
1	1	1	1	Reserved								

APPLICATIONS INFORMATION

Bits B18 and B19 are also used to enable excitation current rotation to automatically remove parasitic thermocouple effects. Parasitic thermocouple effects may arise from the physical connected between the RTD and the measurement instrument. This mode is available for all 4-wire configurations using internal current source excitation.

(4) Excitation Current

The next field in the channel assignment word (B17 to B14) controls the magnitude of the excitation current applied to the RTD (see Table 29). The current selected is the total current flowing through the RTD independent of the wiring configuration. The R_{SENSE} current is 2x the sensor excitation current for 3-wire RTDs.

In order to prevent soft or hard faults, select a current such that the maximum voltage drop across the sensor or sense resistor is nominally 1.0V. For example, if R_{SENSE} is 10k Ω and the RTD is a PT-100, select an excitation current of 100 μ A for 2-wire and 4-wire RTDs and select 50 μ A for a 3-wire RTD. Alternatively, using a 1k Ω sense resistor with a PT-100 RTD allows 500 μ A excitation for any wiring configuration.

Table 29. Total Excitation Current for All RTD Wire Types

(4) EXCITATION CURRENT				
B17	B16	B15	B14	CURRENT
0	0	0	0	Reserved
0	0	0	1	5 μ A
0	0	1	0	10 μ A
0	0	1	1	25 μ A
0	1	0	0	50 μ A
0	1	0	1	100 μ A
0	1	1	0	250 μ A
0	1	1	1	500 μ A
1	0	0	0	1mA

(5) RTD Curve

Bits B13 and B12 set the RTD curve used and the corresponding Callendar-Van Dusen constants (shown in Table 30).

(6) Custom RTD Data Pointer

In the case where an RTD not listed in Table 30 is used, a custom RTD table may be entered into the LTC2983.

See Custom RTD section near the end of this data sheet for more information.

Table 30. RTD Curves: $RT = R0 \cdot (1 + a \cdot T + b \cdot T^2 + (T - 100^\circ\text{C}) \cdot c \cdot T^3)$ for $T < 0^\circ\text{C}$, $RT = R0 \cdot (1 + a \cdot T + b \cdot T^2)$ for $T > 0^\circ\text{C}$

(5) CURVE		CURVE	ALPHA	a	b	c
B13	B12					
0	0	European Standard	0.00385	3.908300E-03	-5.775000E-07	-4.183000E-12
0	1	American	0.003911	3.969200E-03	-5.849500E-07	-4.232500E-12
1	0	Japanese	0.003916	3.973900E-03	-5.870000E-07	-4.400000E-12
1	1	ITS-90	0.003926	3.984800E-03	-5.870000E-07	-4.000000E-12
X	X	RTD1000-375	0.00375	3.810200E-03	-6.018880E-07	-6.000000E-12
X	X	*NI-120	N/A	N/A	N/A	N/A

*NI-120 uses table based data.

APPLICATIONS INFORMATION

Fault Reporting – RTD

Each sensor type has unique fault reporting mechanism indicated in the most significant byte of the data output word. Table 31 shows faults reported in the measurement of RTDs.

Bit D31 indicates the RTD or R_{SENSE} is open, shorted, or not plugged in. This is a hard fault and -999°C or $^{\circ}\text{F}$ is reported. Bit D30 indicates a bad ADC reading. This can be a result of either a broken (open) sensor or an excessive noise event (ESD or static discharge into the sensor path). This

is a hard error and -999°C or $^{\circ}\text{F}$ is reported. In the case of an excessive noise event, the device should recover and the following conversions will be valid if the noise was a random infrequent event. Bits D29 and D28 are not used for RTDs. Bits D27 and D26 indicate over or under temperature limits (see Table 32). The calculated temperature is reported, but the accuracy may be compromised. Bit D25 indicates the absolute voltage measured by the ADC is beyond its normal operating range. If an RTD is used as the cold junction element, any hard or soft error is also flagged in the thermocouple result.

Table 31. RTD Fault Reporting

BIT	FAULT	ERROR TYPE	DESCRIPTION	OUTPUT RESULT
D31	Sensor Hard Fault	Hard	Open or Short RTD or R_{SENSE}	-999°C or $^{\circ}\text{F}$
D30	Hard ADC-Out-of-Range	Hard	Bad ADC Reading (Could Be Large External Noise Event)	-999°C or $^{\circ}\text{F}$
D29	Not Used for RTDs	N/A	Always 0	Valid Reading
D28	Not Used for RTDs	N/A	Always 0	Valid Reading
D27	Sensor Over Range	Soft	$T >$ High Temp Limit (See Table 32)	Suspect Reading
D26	Sensor Under Range	Soft	$T <$ Low Temp Limit (See Table 32)	Suspect Reading
D25	ADC Out-of-Range	Soft	ADC Absolute Input Voltage Is Beyond $\pm 1.125 \cdot V_{REF}/2$	Suspect Reading
D24	Valid	N/A	Result Valid (Should Be 1) Discard Results if 0	Valid Reading

Table 32. Voltage and Resistance Ranges

RTD TYPE	MIN Ω	MAX Ω	LOW TEMP LIMIT $^{\circ}\text{C}$	HIGH TEMP LIMIT $^{\circ}\text{C}$
PT-10	1.95	34.5	-200	850
PT-50	9.75	172.5	-200	850
PT-100	19.5	345	-200	850
PT-200	39	690	-200	850
PT-500	97.5	1725	-200	850
PT-1000	195	3450	-200	850
NI-120	66.6	380.3	-80	260
Custom Table	Lowest Table Entry	Highest Table Entry	Lowest Table Entry	Highest Table Entry

APPLICATIONS INFORMATION

Sense Resistor

Table 33. Sense Resistor Channel Assignment Word

	(1) SENSOR TYPE					(2) SENSE RESISTOR VALUE (Ω)																										
	FIGURE 36					FIGURE 40																										
Measurement Class	31	30	29	28	27	26	25	24	23	22	21	20	19	18	17	16	15	14	13	12	11	10	9	8	7	6	5	4	3	2	1	0
Sense Resistor	Type = 29					Sense Resistor Value (17, 10) Up to $\approx 131,072\Omega$ with $1/1024\Omega$ Resolution																										

Channel Assignment

For each sense resistor tied to the LTC2983, a 32-bit channel assignment word is programmed into a memory location corresponding to the channel the sensor is tied to (see Table 33). This word includes (1) sense resistor selection and (2) sense resistor value.

(1) Sensor Type

The sense resistor is selected by setting the first 5 input bits, B31 to B27, to 11101 (see Table 34).

Table 34. Sense Resistor Selection

(1) SENSOR TYPE					SENSOR TYPE
B31	B30	B29	B28	B27	
1	1	1	0	1	Sense Resistor

(2) Sense Resistor Value

The last field in the channel assignment word (B26 to B0) sets the value of the sense resistor within the range 0 to $131,072\Omega$ with $1/1024\Omega$ precision (see Table 35). The top 17 bits (B26 to B10) create the integer and bits B9 to B0 create the fraction of the sense resistor value.

Example: 2-Wire RTD

The simplest RTD configuration is the 2-wire configuration, 2-wire RTDs follow the general convention shown in Figure 7. They require only two connections per RTD and

Table 35. Example Sense Resistor Values

	(2) SENSE RESISTOR VALUE (Ω)																															
	B26	B25	B24	B23	B22	B21	B20	B19	B18	B17	B16	B15	B14	B13	B12	B11	B10	B9	B8	B7	B6	B5	B4	B3	B2	B1	B0					
Example R	2^{16}	2^{15}	2^{14}	2^{13}	2^{12}	2^{11}	2^{10}	2^9	2^8	2^7	2^6	2^5	2^4	2^3	2^2	2^1	2^0	2^{-1}	2^{-2}	2^{-3}	2^{-4}	2^{-5}	2^{-6}	2^{-7}	2^{-8}	2^{-9}	2^{-10}					
10,000.2 Ω	0	0	0	1	0	0	1	1	1	0	0	0	1	0	0	0	0	0	0	1	1	0	0	1	1	0	1					
99.99521k Ω	1	1	0	0	0	0	1	1	0	1	0	0	1	1	0	1	1	0	0	1	1	0	1	0	1	1	1					
1.0023k Ω	0	0	0	0	0	0	0	1	1	1	1	1	0	1	0	1	0	0	1	0	0	1	1	0	0	1	1					

can be tied directly to 2-lead RTD elements. The disadvantages of this topology are errors due to parasitic lead resistance. If sharing is not selected (1 R_{SENSE} per RTD), then CH_{RTD} should be grounded. The ground connection should be removed if sharing is enabled (1 R_{SENSE} for multiple RTDs).

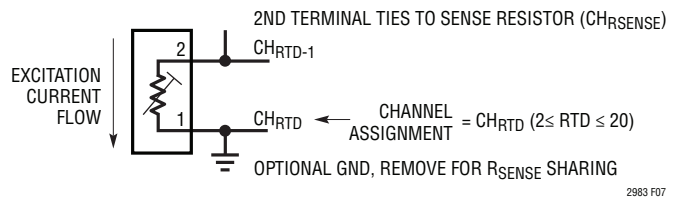

Figure 7. 2-Wire RTD Channel Assignment Convention

Sense resistor channel assignments follow the general convention shown in Figure 8. The sense resistor is tied between CH_{RSNSE} and $CH_{RSNSE-1}$, where CH_{RSNSE} is tied to the 2nd terminal of the RTD. Channel assignment data (see Table 33) is mapped into a memory location corresponding to CH_{RSNSE} .

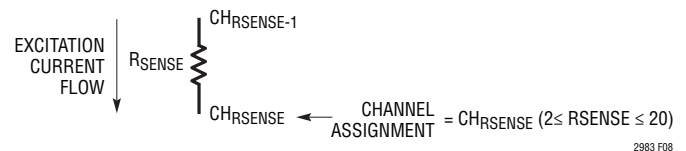

Figure 8. Sense Resistor Channel Assignment Convention for 2-Wire RTDs

APPLICATIONS INFORMATION

Example: 2-Wire RTDs with Shared R_{SENSE}

Figure 9 shows a typical temperature measurement system using multiple 2-wire RTDs. In this example, a PT-1000 RTD ties to CH17 and CH18 and an NI-120 RTD ties to CH19 and CH20. Using this configuration, the LTC2983 can digitize up to nine 2-wire RTDs with a single sense resistor.

RTD #1 sensor type and configuration data are assigned to CH₁₈. 32 bits of binary configuration data are mapped directly into memory locations 0x244 to 0x247 (see Table 36). RTD #2 sensor type and configuration data are assigned to CH₂₀. 32-bits of binary configuration data are mapped directly into memory locations 0x24C to 0x24F

(see Table 37). The sense resistor is assigned to CH₁₆. The user-programmable value of this resistor is 5001.5Ω. 32 bits of binary configuration data are mapped directly into memory locations 0x23C to 0x23F (see Table 38).

A conversion is initiated on CH₁₈ by writing 10010010 into memory location 0x000. Once the conversion is complete, the INTERRUPT pin goes HIGH and memory location 0x000 becomes 01010010. The resulting temperature in °C can be read from memory locations 0x054 to 0x057 (corresponding to CH₁₈). A conversion can be initiated and read from CH₂₀ in a similar fashion.

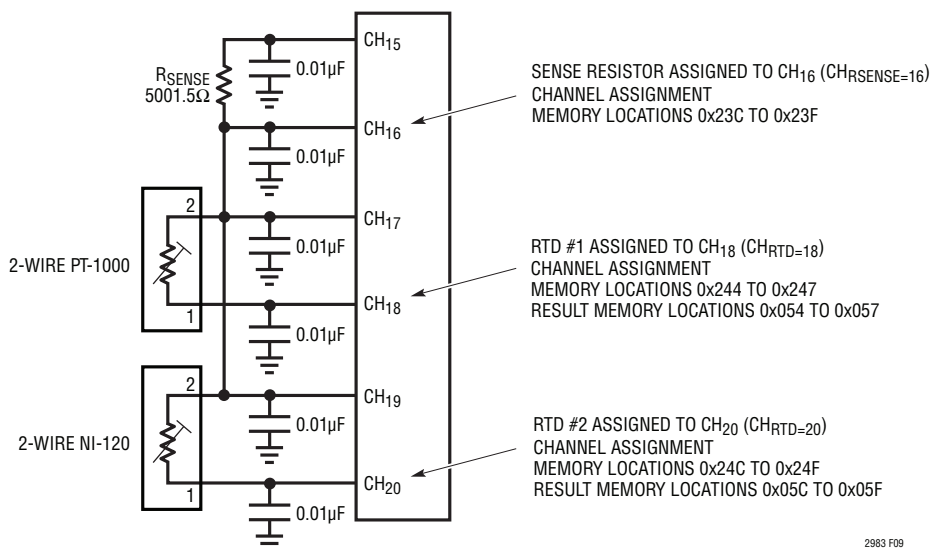

Figure 9. Shared 2-Wire RTD Example

Table 36. Channel Assignment Data for 2-Wire RTD #1 (PT-1000, R_{SENSE} on CH₁₆, 2-Wire, Shared R_{SENSE}, 10μA Excitation Current, α = 0.003916 Curve)

CONFIGURATION FIELD	DESCRIPTION	# BITS	BINARY DATA	MEMORY ADDRESS 0x244	MEMORY ADDRESS 0x245	MEMORY ADDRESS 0x246	MEMORY ADDRESS 0x247
(1) RTD TYPE	PT-1000	5	01111	0 1 1 1 1			
(2) Sense Resistor Channel Pointer	CH ₁₆	5	10000		1 0 0 0 0		
(3) Sensor Configuration	2-Wire with Shared R _{SENSE}	4	0001			0 0 0 1	
(4) Excitation Current	10μA	4	0010			0 0 1 0	
(5) Curve	Japanese, α = 0.003916	2	10				1 0
(6) Custom RTD Data Pointer	Not Custom	12	000000000000				0 0 0 0 0 0 0 0 0 0 0 0

2983fc

APPLICATIONS INFORMATION

Table 37. Channel Assignment Data for 2-Wire RTD #2 (NI-120, R_{SENSE} on CH₁₆, 2-Wire, Shared R_{SENSE}, 100µA Excitation Current)

CONFIGURATION FIELD	DESCRIPTION	# BITS	BINARY DATA	MEMORY ADDRESS 0x24C	MEMORY ADDRESS 0x24D	MEMORY ADDRESS 0x24E	MEMORY ADDRESS 0x24F
(1) RTD TYPE	NI-120	5	10001	1 0 0 0 1			
(2) Sense Resistor Channel Pointer	CH ₁₆	5	10000		1 0 0 0 0		
(3) Sensor Configuration	2-Wire with Shared R _{SENSE}	4	0001			0 0 0 1	
(4) Excitation Current	100µA	4	0101			0 1 0 1	
(5) Curve	European α = 0.00385	2	00			0 0	
(6) Custom RTD Data Pointer	Not Custom	12	000000000000				0 0 0 0 0 0 0 0 0 0 0 0

Table 38. Channel Assignment Data for Sense Resistor (Value = 5001.5Ω)

CONFIGURATION FIELD	DESCRIPTION	# BITS	BINARY DATA	MEMORY ADDRESS 0x23C	MEMORY ADDRESS 0x23D	MEMORY ADDRESS 0x23E	MEMORY ADDRESS 0x23F
(1) Sensor Type	Sense Resistor	5	11101	1 1 1 0 1			
(2) Sense Resistor Value	5001.5Ω	27	000010011100010011000000000		0 0 0 0 1 0 0 1 1 1 0 0 0 1 0 0 1 1 0 0 0 0 0 0 0 0 0 0		

Example: 3-Wire RTD

3-wire RTD channel assignments follow the general convention shown in Figure 10. Terminals 1 and 2 tie to the input/excitation current sources and terminal 3 connects to the sense resistor. Channel assignment data is mapped to memory locations corresponding to CH_{RTD}.

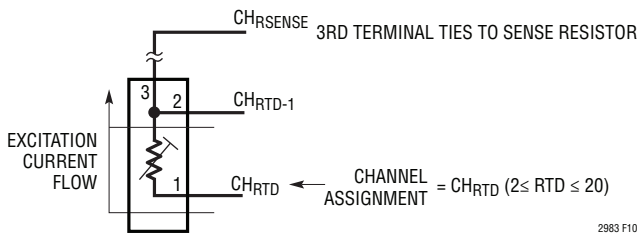

Figure 10. 3-Wire RTD Channel Assignment Convention

Sense resistor channel assignments follow the general convention shown in Figure 11. The sense resistor is tied between CH_{RSENSE} and CH_{RSENSE-1}, where CH_{RSENSE} is tied to the 3rd terminal of the RTD and CH_{RSENSE-1} is tied to ground (or left floating for R_{SENSE} sharing). Channel assignment data (see Table 33) is mapped into the memory location corresponding to CH_{RSENSE}.

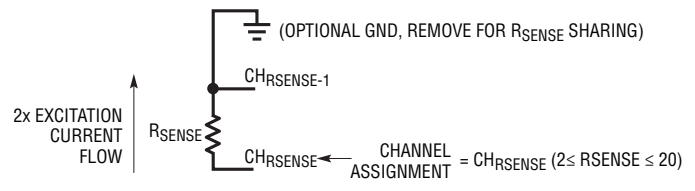

Figure 11. 3-Wire Sense Resistor Channel Assignment Convention for 3-Wire RTDs

APPLICATIONS INFORMATION

Figure 12 shows a typical temperature measurement system using a 3-wire RTD. In this example, a 3-wire RTD's terminals tie to CH₉, CH₈, and CH₇. The sense resistor ties to CH₇ and CH₆. The sense resistor and RTD connect together at CH₇.

The 3-wire RTD reduces the errors associated with parasitic lead resistance by applying excitation current to each RTD input. This first order cancellation removes matched lead resistance errors. This cancellation does not remove

errors due to thermocouple effects or mismatched lead resistances. The RTD sensor type and configuration data are assigned to CH₉. 32 bits of binary configuration data are mapped directly into memory locations 0x220 to 0x223 (see Table 39). The sense resistor is assigned to CH₇. The user-programmable value of this resistor is 12150.39Ω. 32 bits of binary configuration data are mapped directly into memory locations 0x218 to 0x21B (see Table 40).

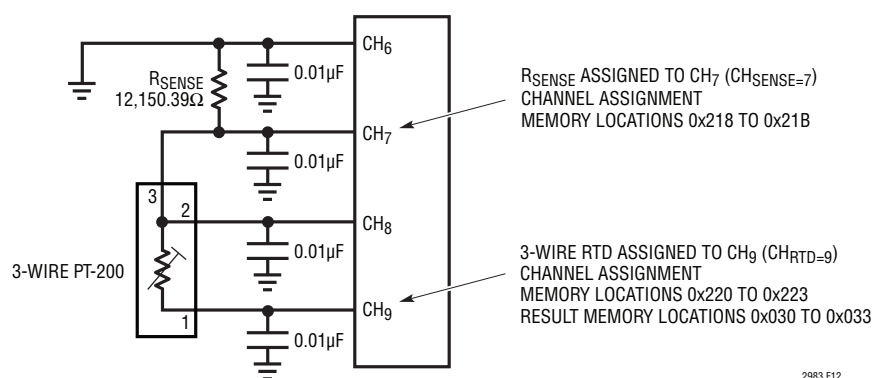

Figure 12. 3-Wire RTD Example

Table 39. Channel Assignment Data for 3-Wire RTD (PT-200, R_{SENSE} on CH₇, 3-Wire, 50μA Excitation Current, α = 0.003911 Curve)

CONFIGURATION FIELD	DESCRIPTION	# BITS	BINARY DATA	MEMORY ADDRESS 0x220	MEMORY ADDRESS 0x221	MEMORY ADDRESS 0x222	MEMORY ADDRESS 0x223
(1) RTD TYPE	PT-200	5	01101	0 1 1 0 1			
(2) Sense Resistor Channel Pointer	CH ₇	5	00111		0 0 1 1 1		
(3) Sensor Configuration	3-Wire	4	0100		0 1 0 0		
(4) Excitation Current	50μA	4	0100		0 1 0 0		
(5) Curve	American, α = 0.003911	2	01			0 1	
(6) Custom RTD Data Pointer	Not Custom	12	000000000000				0 0 0 0 0 0 0 0 0 0 0 0

Table 40. Channel Assignment Data for Sense Resistor (Value = 12150.39Ω)

CONFIGURATION FIELD	DESCRIPTION	# BITS	BINARY DATA	MEMORY ADDRESS 0x218	MEMORY ADDRESS 0x219	MEMORY ADDRESS 0x21A	MEMORY ADDRESS 0x21B
(1) Sensor Type	Sense Resistor	5	11101	1 1 1 0 1			
(2) Sense Resistor Value	12150.39Ω	27	000101111011101100110001111		0 0 0 1 0 1 1 1 1 0 1	1 1 0 1 1 0 0 1 1 0 0 0 1 1 1 0	

APPLICATIONS INFORMATION

A conversion is initiated on CH₉ by writing 10001001 into memory location 0x000. Once the conversion is complete, the INTERRUPT pin goes HIGH and memory location 0x000 becomes 01001001. The resulting temperature in °C can be read from memory locations 0x030 to 0x033 (corresponding to CH₉).

Example: Standard 4-Wire RTD (No Rotation or R_{SENSE} Sharing)

Standard 4-wire RTD channel assignments follow the general convention shown in Figure 13. Terminal 1 is tied to ground, terminals 2 and 3 (Kelvin sensed signal) tie to CH_{RTD} and CH_{RTD-1}, and the 4th terminal ties to the sense resistor. Channel assignment data (see Table 25) is mapped to memory locations corresponding to CH_{RTD}.

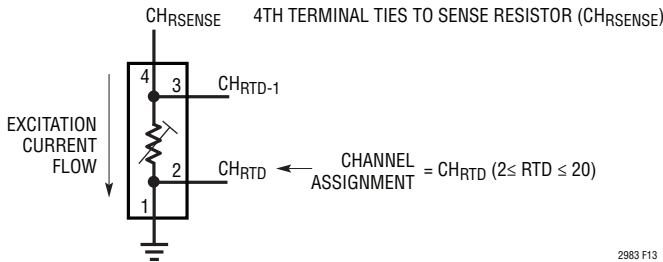

Figure 13. 4-Wire RTD Channel Assignment Convention

Sense resistor channel assignments follow the general convention shown in Figure 14. The sense resistor is tied between CH_{RSENSE} and CH_{SENSE-1}, where CH_{RSENSE} is tied to the 4th terminal of the RTD. Channel assignment data (see Table 33) is mapped into a memory location corresponding to CH_{RSENSE}.

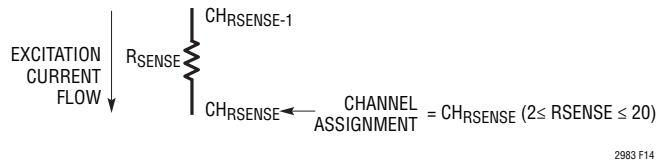

Figure 14. Sense Resistor Channel Assignment Convention for 4-Wire RTDs

APPLICATIONS INFORMATION

Figure 15 shows a typical temperature measurement system using a 4-wire RTD. In this example, a 4-wire RTD's terminals tie to GND, CH₁₃, CH₁₂, and CH₁₁. The sense resistor ties to CH₁₁ and CH₁₀. The sense resistor and RTD share a common connection at CH₁₁. The RTD sensor type and configuration data are assigned to CH₁₃. 32 bits of binary configuration data are mapped directly into memory locations 0x230 to 0x233 (see Table 41). The sense resistor is assigned to CH₁₁. The user programmable value of this resistor is 5000.2Ω.

32 bits of binary configuration data are mapped directly into memory locations 0x228 to 0x22B (see Table 42).

A conversion is initiated on CH₁₃ by writing 10001101 into the data byte at memory location 0x000. Once the conversion is complete, the INTERRUPT pin goes HIGH and memory location 0x000 becomes 01001101. The resulting temperature in °C can be read from memory locations 0x040 to 0x043 (corresponding to CH₁₃).

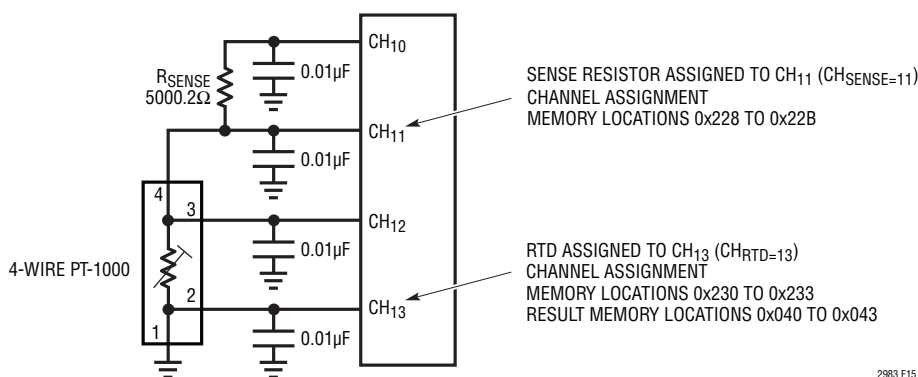

Figure 15. Standard 4-Wire RTD Example

Table 41. Channel Assignment Data for 4-Wire RTD (PT-1000, R_{SENSE} on CH₁₁, Standard 4-Wire, 25μA Excitation Current, α = 0.00385 Curve)

CONFIGURATION FIELD	DESCRIPTION	# BITS	BINARY DATA	MEMORY ADDRESS 0x230	MEMORY ADDRESS 0x231	MEMORY ADDRESS 0x232	MEMORY ADDRESS 0x233
(1) RTD TYPE	PT-1000	5	01111	0 1 1 1 1			
(2) Sense Resistor Channel Pointer	CH ₁₁	5	01011		0 1 0 1 1		
(3) Sensor Configuration	4-Wire, No Rotate, No Share	4	1000		1 0 0 0		
(4) Excitation Current	25μA	4	0011		0 0 1 1		
(5) Curve	European, α=0.00385	2	00			0 0	
(6) Custom RTD Data Pointer	Not Custom	12	000000000000			0 0 0 0 0 0 0 0 0 0 0 0	

Table 42. Channel Assignment Data for Sense Resistor (Value = 5000.2Ω)

CONFIGURATION FIELD	DESCRIPTION	# BITS	BINARY DATA	MEMORY ADDRESS 0x228	MEMORY ADDRESS 0x229	MEMORY ADDRESS 0x22A	MEMORY ADDRESS 0x22B
(1) Sensor Type	Sense Resistor	5	11101	1 1 1 0 1			
(2) Sense Resistor Value	5000.2Ω	27	000010011100010000011001100	0 0 0 0 1 0 0 1 1 1 0 0 0 1 0 0 0 0 0 0 1 1 0 0 1 1 0 0			

2983fc

APPLICATIONS INFORMATION

Example: 4-Wire RTD with Rotation

One method to improve the accuracy of an RTD over the standard 4-wire implementation is by rotating the excitation current source. Parasitic thermocouple effects are automatically removed through autorotation. In order to perform autorotation, the 1st terminal of the RTD ties to CH_{RTD+1} instead of GND, as in the standard case. This allows the LTC2983 to automatically change the direction of the current source without the need for additional external components.

4-wire RTD with rotation channel assignments follow the general convention shown in Figure 16. Terminal 1 is tied to CH_{RTD+1} , terminals 2 and 3 (Kelvin sensed signal) tie to CH_{RTD} and CH_{RTD-1} , and the 4th terminal ties to the

sense resistor. Channel assignment data (see Table 25) is mapped to memory locations corresponding to CH_{RTD} .

Sense resistor channel assignments follow the general convention shown in Figure 17. The sense resistor is tied between CH_{RSENSE} and $CH_{RSENSE-1}$, where CH_{RSENSE} is tied to the 4th terminal of the RTD. Channel assignment data is mapped into a memory location corresponding to CH_{RSENSE} .

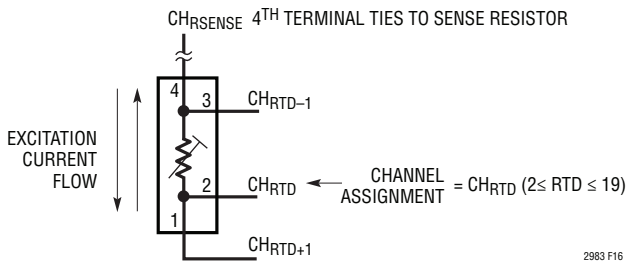

Figure 16. 4-Wire RTD Channel Assignment Convention

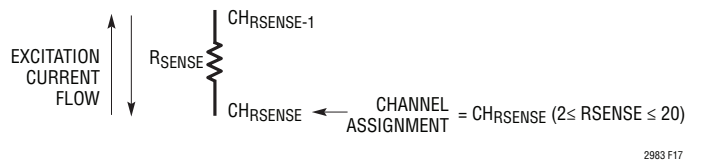

Figure 17. Sense Resistor Channel Assignment Convention for 4-Wire RTDs with Rotation

APPLICATIONS INFORMATION

Figure 18 shows a typical temperature measurement system using a rotating 4-wire RTD. In this example a 4-wire RTD's terminals tie to CH₁₇, CH₁₆, CH₁₅, and CH₆. The sense resistor is tied to CH₆ and CH₅. The sense resistor and RTD connect together at CH₆. The RTD sensor type and configuration data are assigned to CH₁₆. 32 bits of binary configuration data are mapped directly into memory locations 0x23C to 0x23F (see Table 43). The sense resistor is assigned to CH₆.

The user programmable value of this resistor is 10.0102kΩ. 32 bits of binary configuration data are mapped directly into memory locations 0x214 to 0x217 (see Table 44).

A conversion is initiated on CH₁₆ by writing 10010000 into memory location 0x000. Once the conversion is complete, the INTERRUPT pin goes HIGH and memory location 0x000 becomes 01010000. The resulting temperature in °C can be read from memory locations 0x04C to 0x04F (corresponding to CH₁₆).

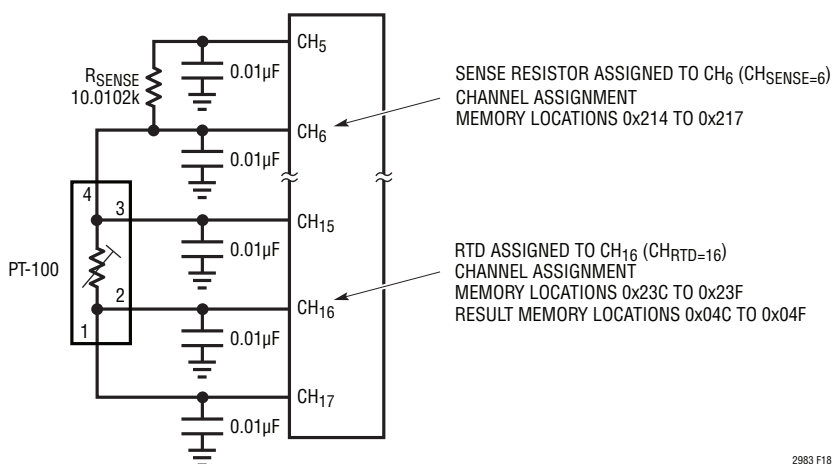

Figure 18. Rotating 4-Wire RTD Example

Table 43. Channel Assignment Data for Rotating 4-Wire RTD (PT-100, R_{SENSE} on CH₆, Rotating 4-Wire, 100µA Excitation Current, α = 0.003911 Curve)

CONFIGURATION FIELD	DESCRIPTION	# BITS	BINARY DATA	MEMORY ADDRESS 0x23C	MEMORY ADDRESS 0x23D	MEMORY ADDRESS 0x23E	MEMORY ADDRESS 0x23F
(1) RTD TYPE	PT-100	5	01100	0 1 1 0 0			
(2) Sense Resistor Channel Pointer	CH ₆	5	00110		0 0 1 1 0		
(3) Sensor Configuration	4-Wire with Rotation	4	1010		1 0 1 0		
(4) Excitation Current	100µA	4	0101			0 1 0 1	
(5) Curve	American, α=0.003911	2	01			0 1	
(6) Custom RTD Data Pointer	Not Custom	12	000000000000				0 0 0 0 0 0 0 0 0 0 0 0

Table 44. Channel Assignment Data for Sense Resistor (Value = 10.0102kΩ)

CONFIGURATION FIELD	DESCRIPTION	# BITS	BINARY DATA	MEMORY ADDRESS 0x214	MEMORY ADDRESS 0x215	MEMORY ADDRESS 0x216	MEMORY ADDRESS 0x217
(1) Sensor Type	Sense Resistor	5	11101	1 1 1 0 1			
(2) Sense Resistor Value	10.0102kΩ	27	000100111000110100011001100		0 0 0 1 0 0 1 1 1 0 0 0 1 1 0 1 0 0 0 1 1 0 0 1 1 0 0		

2983fc

APPLICATIONS INFORMATION

Example: Multiple 4-Wire RTDs with Shared R_{SENSE}

Figure 19 shows a typical temperature measurement system using two 4-wire RTDs with a shared R_{SENSE}. The LTC2983 can support up to six 4-wire RTDs with a single sense resistor. In this example, the first 4-wire RTD's terminals tie to CH₁₇, CH₁₆, CH₁₅, and CH₆ and the 2nd ties to CH₂₀, CH₁₉, CH₁₈, and CH₆. The sense resistor ties to CH₅ and CH₆. The sense resistor and both RTDs connect together at CH₆. This channel assignment convention is identical to that of the rotating RTD. This

topology supports both rotated and non-rotated RTD excitations. Channel assignment data for each sensor is shown in Tables 45 to 47.

A conversion is initiated on CH₁₆ by writing 10010000 into memory location 0x000. Once the conversion is complete, the INTERRUPT pin goes HIGH and memory location 0x000 becomes 01010000. The resulting temperature in °C can be read from memory locations 0x04C to 0x04F (corresponding to CH₁₆). A conversion can be initiated and read from CH₁₉ in a similar fashion.

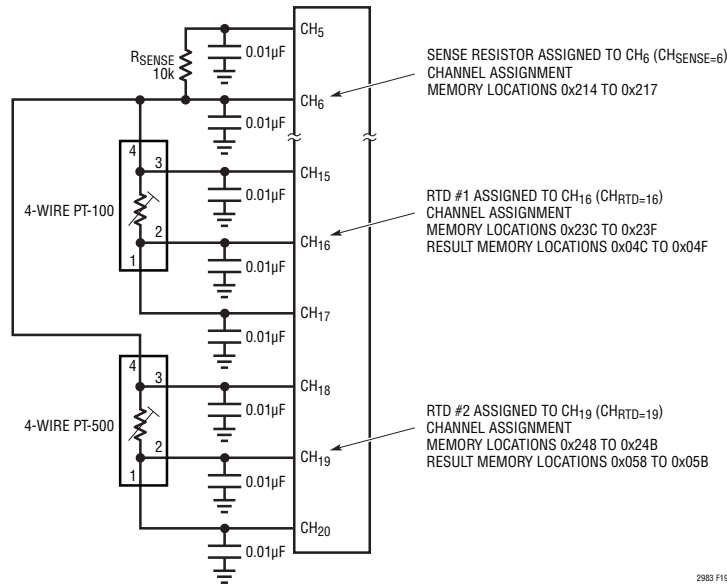

Figure 19. Shared R_{SENSE} 4-Wire RTD Example

Table 45. Channel Assignment Data for 4-Wire RTD #1 (PT-100, R_{SENSE} on CH₆, 4-Wire, Shared R_{SENSE}, Rotated 100µA Excitation Current, α = 0.003926 Curve)

CONFIGURATION FIELD	DESCRIPTION	# BITS	BINARY DATA	MEMORY ADDRESS 0x23C	MEMORY ADDRESS 0x23D	MEMORY ADDRESS 0x23E	MEMORY ADDRESS 0x23F
(1) RTD TYPE	PT-100	5	01100	0 1 1 0 0			
(2) Sense Resistor Channel Pointer	CH ₆	5	00110		0 0 1 1 0		
(3) Sensor Configuration	4-Wire Rotated	4	1010		1 0 1 0		
(4) Excitation Current	100µA	4	0101			0 1 0 1	
(5) Curve	ITS-90, α=0.003926	2	11			1 1	
(6) Custom RTD Data Pointer	Not Custom	12	000000000000				0 0 0 0 0 0 0 0 0 0 0 0

APPLICATIONS INFORMATION

Table 46. Channel Assignment Data for 4-Wire RTD #2 (PT-500, R_{SENSE} on CH_6 , 4-Wire, Rotated $50\mu A$ Excitation Current, $\alpha = 0.003911$ Curve)

CONFIGURATION FIELD	DESCRIPTION	# BITS	BINARY DATA	MEMORY ADDRESS 0x248	MEMORY ADDRESS 0x249	MEMORY ADDRESS 0x24A	MEMORY ADDRESS 0x24B
(1) RTD TYPE	PT-500	5	01110	0 1 1 1 0			
(2) Sense Resistor Channel Pointer	CH_6	5	00110		0 0 1 1 0		
(3) Sensor Configuration	4-Wire Shared, No Rotation	4	1001			1 0 0 1	
(4) Excitation Current	$50\mu A$	4	0100			0 1 0 0	
(5) Curve	American, $\alpha=0.003911$	2	01				0 1
(6) Custom RTD Data Pointer	Not Custom	12	000000000000				0 0 0 0 0 0 0 0 0 0 0 0

Table 47. Channel Assignment Data for Sense Resistor (Value = $10.000k\Omega$)

CONFIGURATION FIELD	DESCRIPTION	# BITS	BINARY DATA	MEMORY ADDRESS 0x214	MEMORY ADDRESS 0x215	MEMORY ADDRESS 0x216	MEMORY ADDRESS 0x217
(1) Sensor Type	Sense Resistor	5	11101	1 1 1 0 1			
(2) Sense Resistor Value	$10.000k\Omega$	27	0001001110001000000000000000		0 0 0 1 0 0 1 1 1 0 0 0 1 0 0 0 0 0 0 0 0 0 0 0 0 0 0		

Example: 4-Wire RTD with Kelvin R_{SENSE}

It is possible to cancel the parasitic lead resistance in the sense resistors by configuring the 4-wire RTD with a 4-wire (Kelvin connected) sense resistor. This is useful when using a PT-10 or PT-50 with a small valued R_{SENSE} or when the sense resistor is remotely located or in applications requiring extreme precision.

The 4-wire RTD channel assignments follow the general conventions previously defined (Figures 14 and 16) for a standard 4-wire RTD. The sense resistor follows the convention shown in Figure 20.

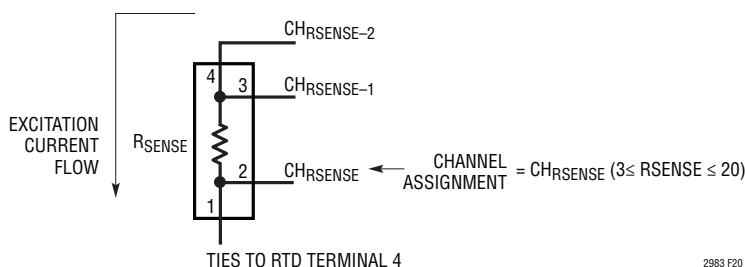

Figure 20. Sense Resistor with Kelvin Connections Channel Assignment Convention

APPLICATIONS INFORMATION

Figure 21 shows a typical temperature measurement system using a 4-wire RTD with a Kelvin connected R_{SENSE} . In this example, the 4-wire RTD's terminals tie to CH₁₇, CH₁₆, CH₁₅, and CH₆. The sense resistor ties to CH₆, CH₅, and CH₄ and excitation current is applied to CH₄ and CH₁₇. The sense resistor's nominal value is 1k Ω in order to accommodate a 1mA excitation current. The sense resistor and RTD connect together at CH₆. This topology supports both rotated, shared and standard 4-wire RTD topologies. If rotated or shared

configuration are not used then terminal 1 of the RTD is tied to ground instead of CH₁₇, freeing up one input channel. Channel assignment data is shown in Tables 48 and 49.

A conversion is initiated on CH₁₆ by writing 10010000 into memory location 0x000. Once the conversion is complete, the INTERRUPT pin goes HIGH and memory location 0x000 becomes 01010000 (see Table 6). The resulting temperature in $^{\circ}\text{C}$ can be read from memory locations 0x04C to 0x04F (corresponding to CH₁₆).

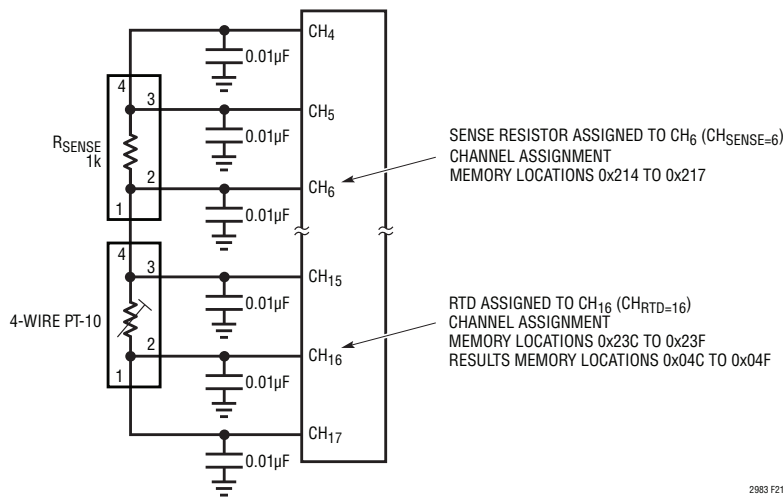

Figure 21. Sense Resistor with Kelvin Connections Example

Table 48. Channel Assignment Data for 4-Wire RTD with Kelvin Connected R_{SENSE} (PT-10, R_{SENSE} on CH₆, 4-Wire, Kelvin R_{SENSE} with Rotated 1mA Excitation Current, $\alpha = 0.003916$ Curve)

CONFIGURATION FIELD	DESCRIPTION	# BITS	BINARY DATA	MEMORY ADDRESS 0x23C	MEMORY ADDRESS 0x23D	MEMORY ADDRESS 0x23E	MEMORY ADDRESS 0x23F
(1) RTD TYPE	PT-10	5	01010	0 1 0 1 0			
(2) Sense Resistor Channel Pointer	CH ₆	5	00110	0 0 1 1 0			
(3) Sensor Configuration	4-Wire Kelvin R_{SENSE} and Rotation	4	1110		1 1 1 0		
(4) Excitation Current	1mA	4	1000			1 0 0 0	
(5) Curve	Japanese, $\alpha=0.003916$	2	10			1 0	
(6) Custom RTD Data Pointer	Not Custom	12	000000000000				0 0 0 0 0 0 0 0 0 0 0 0

Table 49. Channel Assignment Data for Sense Resistor (Value = 1000 Ω)

CONFIGURATION FIELD	DESCRIPTION	# BITS	BINARY DATA	MEMORY ADDRESS 0x214	MEMORY ADDRESS 0x215	MEMORY ADDRESS 0x216	MEMORY ADDRESS 0x217
(1) Sensor Type	Sense Resistor	5	11101	1 1 1 0 1			
(2) Sense Resistor Value	1000 Ω	27	0000000111110100000000000000	0 0 0 0 0 0 0 0 1 1 1 1 1 0 1 0 0 0 0 0 0 0 0 0 0 0 0			

APPLICATIONS INFORMATION

THERMISTOR MEASUREMENTS

Channel Assignment – Thermistor

For each thermistor tied to the LTC2983, a 32-bit channel assignment word is programmed into a memory location corresponding to the channel the sensor is tied to (see Table 50). This data includes (1) thermistor type, (2) sense resistor channel pointer, (3) sensor configuration, (4) excitation current, (5) Steinhart-Hart address pointer or custom table address pointer.

(1) Thermistor Type

The thermistor type is determined by the first five input bits (B31 to B27) as shown in Table 51. Linearization coefficients based on Steinhart-Hart equation for commonly used Thermistor types 44004/44033, 44005/44030, 44006/44031, 44007/44034, 44008/44032 and YSI-400 are built into the device. If other custom thermistors are used, Thermistor Custom Steinhart-Hart or Thermistor Custom Table (temperature vs resistance) can be selected. In this case, user specific data can be stored in the on-chip RAM starting at the address defined in Thermistor Custom Steinhart-Hart or Thermistor Custom Table address pointers.

Table 50. Thermistor Channel Assignment Word

	(1) THERMISTOR TYPE					(2) SENSE RESISTOR CHANNEL POINTER					(3) SENSOR CONFIGURATION			(4) EXCITATION CURRENT				(5) CUSTOM THERMISTOR DATA POINTER														
	TABLE 51					TABLE 27					TABLE 52			TABLE 53				TABLES 76, 77, 78, 80, 81														
Measurement Class	31	30	29	28	27	26	25	24	23	22	21	20	19	18	17	16	15	14	13	12	11	10	9	8	7	6	5	4	3	2	1	0
Thermistor	Type = 19 to 27					R _{SENSE} Channel Pointer [4:0]					SGL = 1 DIFF = 0			Excitation Mode Excitation Current [3:0]				Not Used 0 0 0			Custom Address [5:0]					Custom Length – 1 [5:0]						

Table 51. Thermistor Type: $1/T = A + B \cdot \ln(R) + C \cdot \ln(R)^2 + D \cdot \ln(R)^3 + E \cdot \ln(R)^4 + F \cdot \ln(R)^5$

B31	B30	B29	B28	B27	THERMISTOR TYPE	A	B	C	D	E	F
1	0	0	1	1	Thermistor 44004/44033 2.252kΩ at 25°C	1.46800E-03	2.38300E-04	0	1.00700E-07	0	0
1	0	1	0	0	Thermistor 44005/44030 3kΩ at 25°C	1.40300E-03	2.37300E-04	0	9.82700E-08	0	0
1	0	1	0	1	Thermistor 44007/44034 5kΩ at 25°C	1.28500E-03	2.36200E-04	0	9.28500E-08	0	0
1	0	1	1	0	Thermistor 44006/44031 10kΩ at 25°C	1.03200E-03	2.38700E-04	0	1.58000E-07	0	0
1	0	1	1	1	Thermistor 44008/44032 30kΩ at 25°C	9.37600E-04	2.20800E-04	0	1.27600E-07	0	0
1	1	0	0	0	Thermistor YSI-400 2.252kΩ at 25°C	1.47134E-03	2.37624E-04	0	1.05034E-07	0	0
1	1	0	0	1	Spectrum 1003k 1kΩ at 25°C	1.445904E-3	2.68399E-04	0	1.64066E-07	0	0
1	1	0	1	0	Thermistor Custom Steinhart-Hart	user input	user input	user input	user input	user input	user input
1	1	0	1	1	Thermistor Custom Table	not used	not used	not used	not used	not used	not used

APPLICATIONS INFORMATION

(2) Sense Resistor Channel Pointer

Thermistor measurements are performed ratiometrically relative to a known R_{SENSE} resistor. The sense resistor channel pointer field indicates the differential channel the sense resistor is tied to for the current thermistor (see Table 27).

(3) Sensor Configuration

The sensor configuration field is used to define various thermistor properties. Configuration bit B21 is set high for single-ended (measurement relative to COM) and low for differential (see Table 52).

The next sensor configuration bits (B19 and B20) determine the excitation current mode. These bits are used to enable R_{SENSE} sharing, where one sense resistor is used for multiple thermistors. In this case, the thermistor ground connection is internal and each thermistor points to the same R_{SENSE} channel.

Bits B19 and B20 are also used to enable excitation current rotation to automatically remove parasitic thermocouple effects. Parasitic thermocouple effects may arise from the physical connection between the thermistor and the measurement instrument. This mode is available for differential thermistor configurations using internal current source excitation.

Table 52. Sensor Configuration Data

(3) SENSOR CONFIGURATION			SINGLE-ENDED/ DIFFERENTIAL	SHARE R_{SENSE}	ROTATE
SGL	EXCITATION MODE				
B21	B20	B19			
0	0	0	Differential	No	No
0	0	1	Differential	Yes	Yes
0	1	0	Differential	Yes	No
0	1	1		Reserved	
1	0	0	Single-Ended	No	No
1	0	1		Reserved	
1	1	0		Reserved	
1	1	1		Reserved	

(4) Excitation Current

The next field in the channel assignment word (B18 to B15) controls the magnitude of the excitation current applied to the thermistor (see Table 53). In order to prevent hard or soft faults, select a current such that the maximum voltage drop across the sensor or sense resistor is nominally 1.0V. The LTC2983 has no special requirements related to the ratio between the voltage drop across the sense resistor and the sensor. Consequently, it is possible to have a sense resistor several orders of magnitude smaller than the maximum sensor value. For optimal performance over the full thermistor temperature range, auto ranged current can be selected. In this case, the LTC2983 conversion is performed in three cycles (instead of the standard two cycles) (see Table 64). The first cycle determines the optimal excitation current for the sensor resistance value and R_{SENSE} value. The following two cycles use that current to measure the thermistor temperature.

Table 53. Excitation Current for Thermistors

(4) EXCITATION CURRENT				CURRENT
B18	B17	B16	B15	
0	0	0	0	Reserved
0	0	0	1	250nA
0	0	1	0	500nA
0	0	1	1	1 μ A
0	1	0	0	5 μ A
0	1	0	1	10 μ A
0	1	1	0	25 μ A
0	1	1	1	50 μ A
1	0	0	0	100 μ A
1	0	0	1	250 μ A
1	0	1	0	500 μ A
1	0	1	1	1mA
1	1	0	0	Auto Range*
1	1	0	1	Invalid
1	1	1	0	Invalid
1	1	1	1	Reserved

*Auto Range not allowed for custom sensors

(5) Steinhart-Hart Address/Custom Table Address

See Custom Thermistors section near the end of this data sheet for more information.

APPLICATIONS INFORMATION

Fault Reporting – Thermistor

Each sensor type has unique fault reporting mechanism indicated in the upper byte of the data output word. Table 54 shows faults reported during the measurement of thermistors.

Bit D31 indicates the thermistor or R_{SENSE} is open, shorted, or not plugged in. This is a hard fault and -999°C is reported. Bit D30 indicates a bad ADC reading. This could be a result of either a broken (open) sensor or an excessive noise event (ESD or static discharge into the sensor path).

This is a hard error and -999°C is output. In the case of an excessive noise event, the device should recover and the following conversions will be valid if the noise event was a random infrequent event. Bits D29 and D28 are not used for thermistors. Bits D27 and D26 indicate the reading is over or under temperature limits (see Table 55). The calculated temperature is reported, but the accuracy may be compromised. Bit D25 indicates the absolute voltage measured by the ADC is beyond its normal operating range. If a thermistor is used as the cold junction element, any hard or soft error is flagged in the thermocouple result.

Table 54. Thermistor Fault Reporting

BIT	FAULT	ERROR TYPE	DESCRIPTION	OUTPUT RESULT
D31	Sensor Hard Fault	Hard	Open or Short Thermistor or R_{SENSE}	-999°C
D30	Hard ADC-Out-of-Range	Hard	Bad ADC Reading (Could Be Large External Noise Event)	-999°C
D29	Not Used for Thermistors	N/A	Always 0	Valid Reading
D28	Not Used for Thermistors	N/A	Always 0	Valid Reading
D27	Sensor Over Range*	Soft	$T > \text{High Temp Limit}$	Suspect Reading
D26	Sensor Under Range*	Soft	$T < \text{Low Temp Limit}$	Suspect Reading
D25	ADC Out-of-Range	Soft	ADC Absolute Input Voltage Is Beyond $\pm 1.125 \cdot V_{REF}/2$	Suspect Reading
D24	Valid	N/A	Result Valid (Should Be 1) Discard Results if 0	Valid Reading

*Do not apply to custom Steinhart-Hart sensor type. Custom table thermistor over/under range is determined by the resistor table values, see custom thermistor table example for details.

APPLICATIONS INFORMATION

Table 55. Thermistor Temperature/Resistance Range

THERMISTOR TYPE	MIN (Ω)	MAX (Ω)	LOW Temp Limit ($^{\circ}\text{C}$)	HIGH Temp Limit ($^{\circ}\text{C}$)
Thermistor 44004/44033 2.252k Ω at 25 $^{\circ}\text{C}$	41.9	75.79k	-40	150
Thermistor 44005/44030 3k Ω at 25 $^{\circ}\text{C}$	55.6	101.0k	-40	150
Thermistor 44007/44034 5k Ω at 25 $^{\circ}\text{C}$	92.7	168.3k	-40	150
Thermistor 44006/44031 10k Ω at 25 $^{\circ}\text{C}$	237.0	239.8k	-40	150
Thermistor 44008/44032 30k Ω at 25 $^{\circ}\text{C}$	550.2	884.6k	-40	150
Thermistor YSI 400 2.252k Ω at 25 $^{\circ}\text{C}$	6.4	1.66M	-80	250
Spectrum 1003K 1k Ω at 25 $^{\circ}\text{C}$	51.1	39.51k	-50	125
Thermistor Custom Steinhart-Hart	N/A	N/A	N/A	N/A
Thermistor Custom Table	Second Table Entry	Last Table Entry		

Example: Single-Ended Thermistor

The simplest thermistor configuration is the single-ended configuration. Thermistors using this configuration share a common ground (COM) between all sensors and are each tied to a unique sense resistor (R_{SENSE} sharing is not allowed for single-ended thermistors). Single-ended thermistors follow the convention shown in Figure 22. Terminal 1 ties to ground (COM) and terminal 2 ties to CH_{THERM} and the sense resistor. Channel assignment data (see Table 50) is mapped to memory locations corresponding to CH_{THERM} .

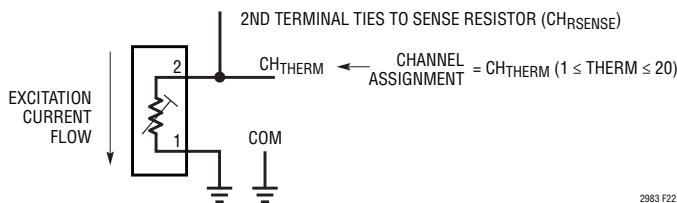

Figure 22. Single-Ended Thermistor Channel Assignment Convention

Sense resistor channel assignments follow the general convention shown in Figure 23. The sense resistor is tied between $\text{CH}_{\text{RSENSE}}$ and $\text{CH}_{\text{RSENSE}-1}$, where $\text{CH}_{\text{RSENSE}}$ is tied to the 2nd terminal of the thermistor. Channel assignment data (see Table 33) is mapped into the memory location corresponding to $\text{CH}_{\text{RSENSE}}$.

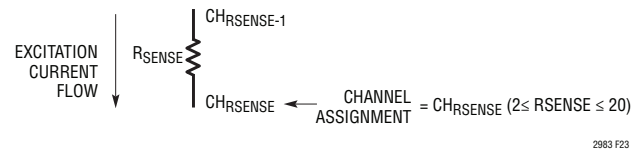

Figure 23. Sense Resistor Channel Assignment Convention

APPLICATIONS INFORMATION

Figure 24 shows a typical temperature measurement system using a single-ended thermistor. In this example a 10kΩ (44031 type) thermistor is tied to a 10.1kΩ sense resistor. The thermistor is assigned channel CH5 (memory locations 0x210 to 0x213) and the sense resistor to CH4 (memory locations 0x20C to 0x20F). Channel assignment data are shown in Tables 56 and 57.

A conversion is initiated on CH5 by writing 10000101 into memory location 0x000. Once the conversion is complete, the INTERRUPT pin goes HIGH and memory location 0x000 becomes 01000101. The resulting temperature in °C can be read from memory locations 0x020 to 0x023 (corresponding to CH5).

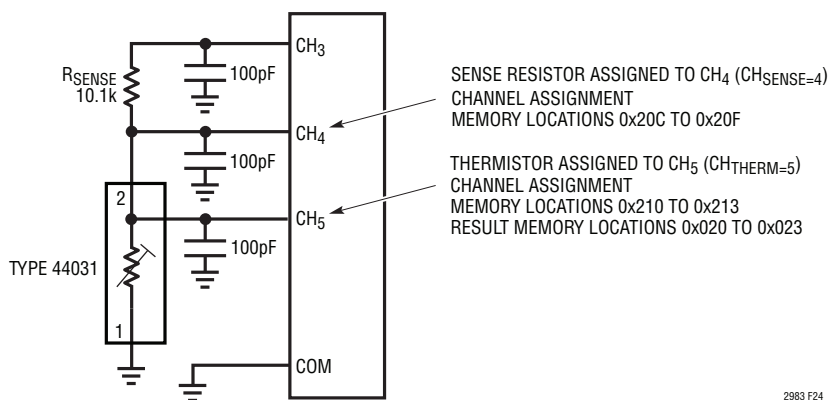

Figure 24. Single-Ended Thermistor Example

Table 56. Channel Assignment Data for Single-Ended Thermistor (44006/44031 10kΩ at 25°C Type Thermistor, Single-Ended Configuration, RSENSE on CH4, 1μA Excitation Current)

CONFIGURATION FIELD	DESCRIPTION	# BITS	BINARY DATA	MEMORY ADDRESS 0x210	MEMORY ADDRESS 0x211	MEMORY ADDRESS 0x212	MEMORY ADDRESS 0x213
(1) Thermistor Type	44006/44031 10kΩ at 25°C	5	10110	1 0 1 1 0			
(2) Sense Resistor Channel Pointer	CH4	5	00100		0 0 1 0 0		
(3) Sensor Configuration	Single-Ended	3	100		1 0 0		
(4) Excitation Current	1μA	4	0011		0 0 1 1		
Not Used	Set These Bits to 0	3	000			0 0 0	
(5) Custom RTD Data Pointer	Not Custom	12	000000000000				0 0 0 0 0 0 0 0 0 0 0 0

Table 57. Channel Assignment Data for Sense Resistor (Value = 10.1kΩ)

CONFIGURATION FIELD	DESCRIPTION	# BITS	BINARY DATA	MEMORY ADDRESS 0x20C	MEMORY ADDRESS 0x20D	MEMORY ADDRESS 0x20E	MEMORY ADDRESS 0x20F
(1) Sensor Type	Sense Resistor	5	11101	1 1 1 0 1			
(2) Sense Resistor Value	10.1kΩ	27	00010011101110100000000000		0 0 0 1 0 0 1 1 1 0 1 1 1 0 1 0 0 0 0 0 0 0 0 0 0 0		

APPLICATIONS INFORMATION

Example: Differential Thermistor

The differential thermistor configuration allows separate ground sensing for each sensor. In this standard differential configuration, one sense resistor is used for each thermistor. Differential thermistors follow the convention shown in Figure 25. Terminal 1 ties to CH_{THERM} and is shorted to ground and terminal 2 ties $CH_{THERM-1}$ to and the sense resistor. Channel assignment data (see Table 50) is mapped to memory locations corresponding to CH_{THERM} .

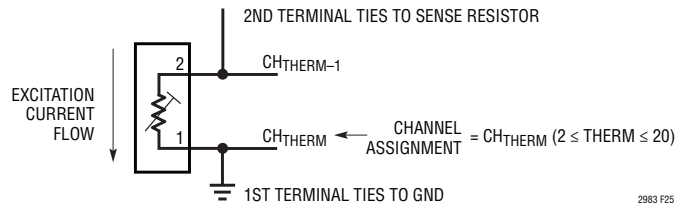

Figure 25. Differential Thermistor Channel Assignment Convention

Sense resistor channel assignments follow the general convention shown in Figure 26. The sense resistor is tied between CH_{RSENSE} and $CH_{RSENSE-1}$, where CH_{RSENSE} is tied to the 2nd terminal of the thermistor. Channel assignment data (see Table 33) is mapped into a memory location corresponding to CH_{RSENSE} .

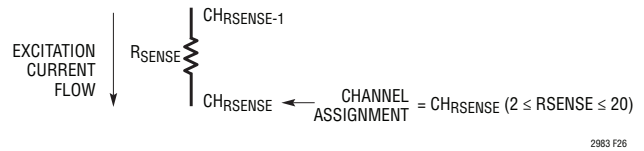

Figure 26. Sense Resistor Channel Assignment Convention

APPLICATIONS INFORMATION

Figure 27 shows a typical temperature measurement system using a differential thermistor. In this example a 30kΩ (44032 type) thermistor is tied to a 9.99kΩ sense resistor. The thermistor is assigned channel CH13 (memory locations 0x230 to 0x233) and the sense resistor to CH11 (memory locations 0x228 to 0x22B). Channel assignment data is shown in Tables 58 and 59).

A conversion is initiated on CH₁₃ by writing 10001101 into memory location 0x000. Once the conversion is complete, the INTERRUPT pin goes HIGH and memory location 0x000 becomes 01001101. The resulting temperature in °C can be read from memory locations 0x040 to 0x043 (Corresponding to CH₁₃).

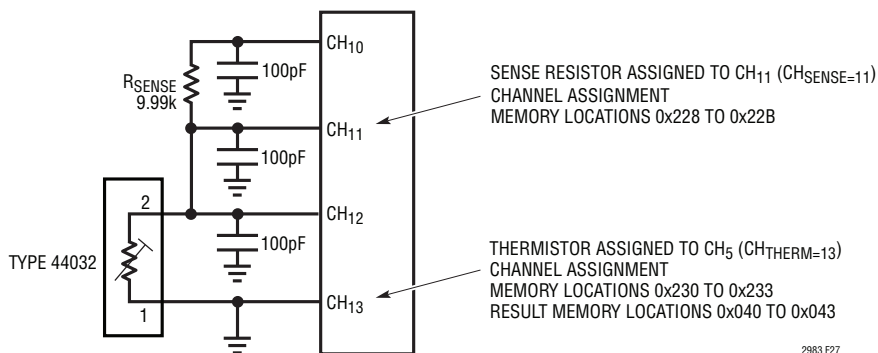

Figure 27. Differential Thermistor Example

Table 58. Channel Assignment Data for Differential Thermistor (44008/44032 30kΩ at 25°C Type Thermistor, Differential Configuration, R_{SENSE} on CH₁₁, Auto Range Excitation)

CONFIGURATION FIELD	DESCRIPTION	# BITS	BINARY DATA	MEMORY ADDRESS 0x230	MEMORY ADDRESS 0x231	MEMORY ADDRESS 0x232	MEMORY ADDRESS 0x233
(1) Thermistor Type	44008/44032 30kΩ at 25°C	5	10111	1 0 1 1 1			
(2) Sense Resistor Channel Pointer	CH ₁₁	5	01011		0 1 0 1 1		
(3) Sensor Configuration	Differential, No Share, No Rotate	3	000		0 0 0		
(4) Excitation Current	Auto Range	4	1100		1 1 0 0		
Not Used	Set These Bits to 0	2	000			0 0 0	
(5) Custom RTD Data Pointer	Not Custom	12	000000000000				0 0 0 0 0 0 0 0 0 0 0 0

Table 59. Channel Assignment Data for Sense Resistor (Value = 9.99kΩ)

CONFIGURATION FIELD	DESCRIPTION	# BITS	BINARY DATA	MEMORY ADDRESS 0x228	MEMORY ADDRESS 0x229	MEMORY ADDRESS 0x22A	MEMORY ADDRESS 0x22B
(1) Sensor Type	Sense Resistor	5	11101	1 1 1 0 1			
(2) Sense Resistor Value	9.99kΩ	27	000100111000001100000000000		0 0 0 1 0 0 1 1 1 0 0 0 0 0 0 1 1 0 0 0 0 0 0 0 0 0 0		

2983fc

APPLICATIONS INFORMATION

Example: Shared/Rotated Differential Thermistor

The differential thermistor configuration allows separate internal ground sensing for each sensor. In this configuration, one sense resistor can be used for multiple thermistors. Differential thermistors follow the convention shown in Figure 28. Terminal 1 ties to CH_{THERM} and terminal 2 ties to $CH_{THERM-1}$ and the sense resistor. Channel assignment data (see Table 50) is mapped to memory locations corresponding to CH_{THERM} .

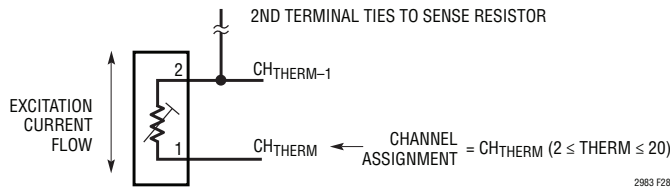

Figure 28. Thermistor with Shared R_{SENSE} Channel Assignment Convention

Sense resistor channel assignments follow the general convention shown in Figure 29. The sense resistor is tied between CH_{RSENSE} and $CH_{RSENSE-1}$, where CH_{SENSE} is tied to the 2nd terminal of the thermistor. Channel assignment data (see Table 33) is mapped into a memory location corresponding to CH_{THERM} .

Figure 30 shows a typical temperature measurement system using a shared sense resistor and one rotated/one non-rotated differential thermistors. In this example

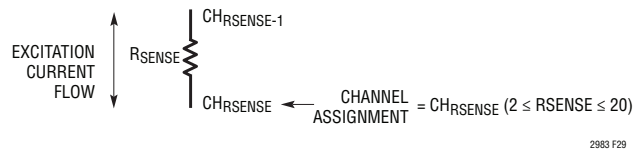

Figure 29. Sense Resistor Channel Assignment Convention for Thermistors

APPLICATIONS INFORMATION

a 30kΩ (44032 Type) thermistor is tied to a 10.0kΩ sense resistor and configured as rotated/shared. The second thermistor a 2.25kΩ (44004 Type) is configured as a non-rotated/shared. Channel assignment data are shown in Tables 60 to 62.

A conversion is initiated on CH₁₈ by writing 10010010 into memory location 0x000. Once the conversion is complete, the INTERRUPT pin goes HIGH and memory location 0x000 becomes 01010010. The resulting temperature in °C can be read from memory locations 0x054 to 0x057 (corresponding to CH₁₆). A conversion can be initiated and read from CH₂₀ in a similar fashion.

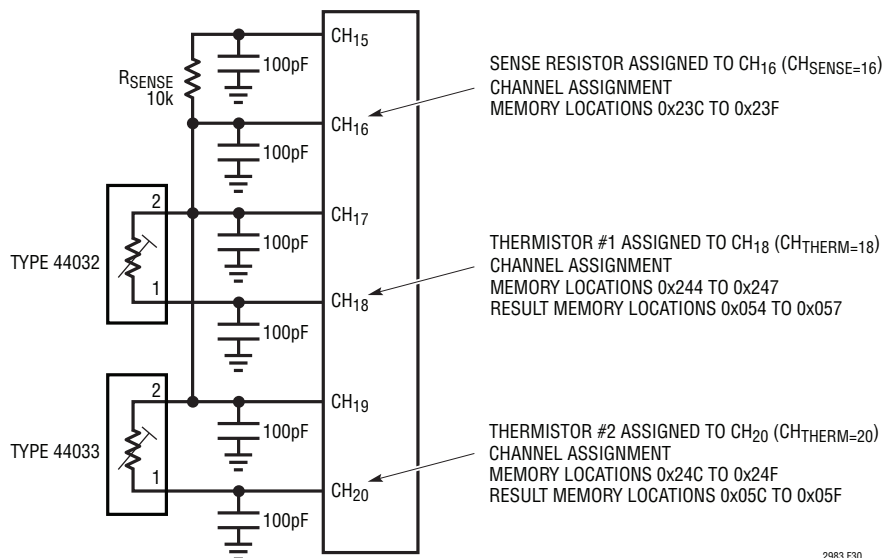

Figure 30. Rotated and Shared Thermistor Example

Table 60. Channel Assignment Data Differential Thermistor (44008/44032 30kΩ at 25°C Type Thermistor, Differential Configuration with Sharing and Rotation, R_{SENSE} on CH₁₆, 250nA Excitation Current)

CONFIGURATION FIELD	DESCRIPTION	# BITS	BINARY DATA	MEMORY ADDRESS 0x244	MEMORY ADDRESS 0x245	MEMORY ADDRESS 0x246	MEMORY ADDRESS 0x247
(1) Thermistor Type	44008/44032 30kΩ at 25°C	5	10111	1 0 1 1 1			
(2) Sense Resistor Channel Pointer	CH ₁₆	5	10000		1 0 0 0 0		
(3) Sensor Configuration	Differential, Rotate and Shared	3	001		0 0 1		
(4) Excitation Current	250nA Excitation Current	4	0001		0 0 0 1		
Not Used	Set These Bits to 0	3	000			0 0 0	
(5) Custom RTD Data Pointer	Not Custom	12	000000000000				0 0 0 0 0 0 0 0 0 0 0 0

APPLICATIONS INFORMATION

Table 61. Channel Assignment Data Differential Thermistor (44004/44033 2.252kΩ at 25°C Type Thermistor, Differential Configuration with Sharing and No Rotation, R_{SENSE} on CH₁₆, 10μA Excitation Current)

Configuration Field	Description	# Bits	Binary Data	MEMORY ADDRESS 0x24C	MEMORY ADDRESS 0x24D	MEMORY ADDRESS 0x24E	MEMORY ADDRESS 0x24F
(1) Thermistor Type	44004/44033 2.252kΩ at 25°C	5	10011	1 0 0 1 1			
(2) Sense Resistor Channel Pointer	CH ₁₆	5	10000		1 0 0 0 0		
(3) Sensor Configuration	Differential, No Rotate and Shared	3	010			0 1 0	
(4) Excitation Current	10μA Excitation Current	4	0101			0 1 0 1	
Not Used	Set These Bits to 0	3	000			0 0 0	
(5) Custom RTD Data Pointer	Not Custom	12	000000000000				0 0 0 0 0 0 0 0 0 0 0 0

Table 62. Channel Assignment Data for Sense Resistor (Value = 10.0kΩ)

Configuration Field	Description	# Bits	Binary Data	MEMORY ADDRESS 0x23C	MEMORY ADDRESS 0x23D	MEMORY ADDRESS 0x23E	MEMORY ADDRESS 0x23F
(1) Sensor Type	Sense Resistor	5	11101	1 1 1 0 1			
(2) Sense Resistor Value	10.0kΩ	27	0001001110001000000000000000		0 0 0 1 0 0 1 1 1 0 0 0 1 0 0 0 0 0 0 0 0 0 0 0 0 0 0		

APPLICATIONS INFORMATION

Typical Application Thermocouple Measurements

The LTC2983 includes 20 fully configurable analog input channels. Each input channel can be configured to accept any sensor type. Figure 31 shows a typical application digitizing multiple thermocouples. Each thermocouple requires a cold junction sensor and each cold junction sensor can be shared amongst multiple thermocouples.

For example, the thermocouple tied to CH1 can use the diode tied to CH2 as a cold junction sensor. However, any thermocouple (CH1, CH3, CH5, CH6, CH9, CH10, or CH16) can use any diode (CH2, CH4, or CH7), RTD (CH13, CH14), or Thermistor (CH19, CH20) as its cold junction compensation. The LTC2983 simultaneously measures both the thermocouple and cold junction sensor and outputs the results in °C or °F.

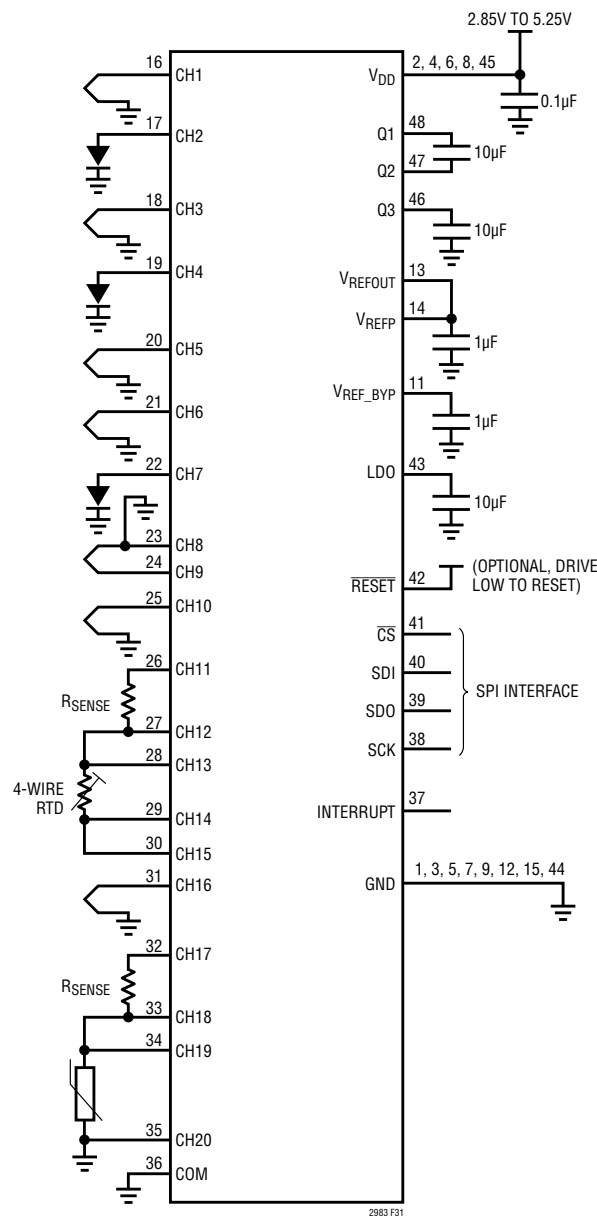

Figure 31. Typical Thermocouple Application

APPLICATIONS INFORMATION

Typical Application RTD and Thermistor Measurements

The LTC2983 includes 20 fully configurable analog input channels. Each input channel can be configured to accept any sensor type. Figure 32 shows a typical application digitizing multiple RTDs and thermistors. Each RTD/thermistor requires a sense resistor which can be shared with multiple sensors. RTDs can be configured as 2, 3, or 4-wire topologies. For example, a single sense resistor

(CH1, CH2) is shared between a 4-wire RTD (CH4, CH3), a 2-wire RTD (CH7, CH6), two 3-wire RTDs (CH9, CH8 and CH11, CH10) and a thermistor (CH13, CH12). This can be mixed with diode sensors (CH15) and thermocouples (CH14). Sense resistors (CH17, CH16) can also be dedicated to specific sensors, in this case a 4-wire RTD (CH19, CH18). Current is applied through both the sense resistor and RTD/Thermistor, the resulting voltages are simultaneously measured and the results are output in °C or °F.

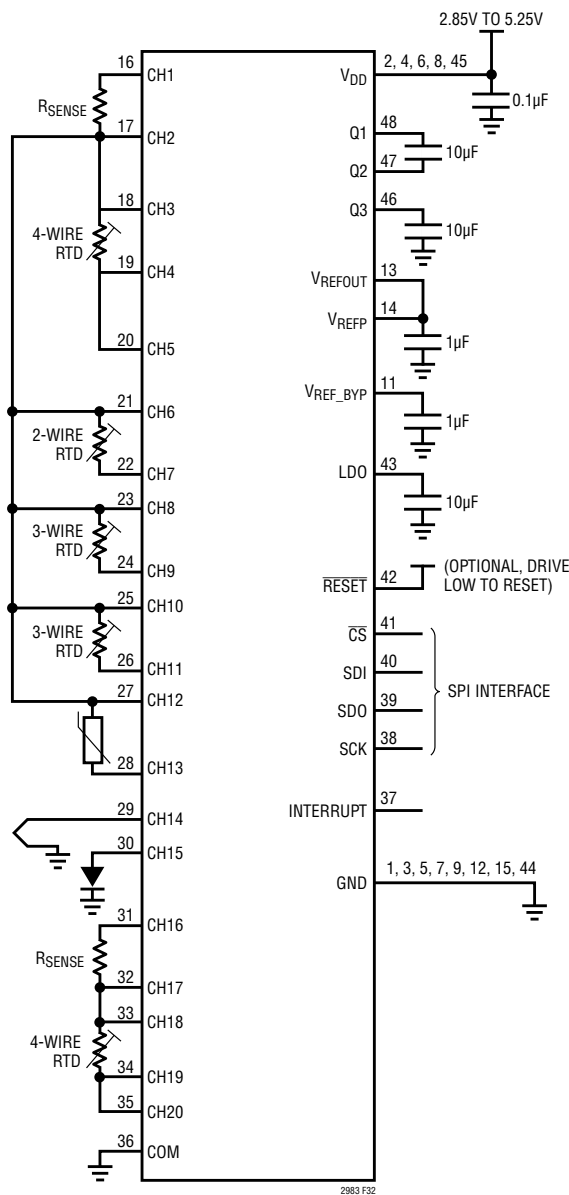

Figure 32. Typical RTD/Thermistor Application

SUPPLEMENTAL INFORMATION

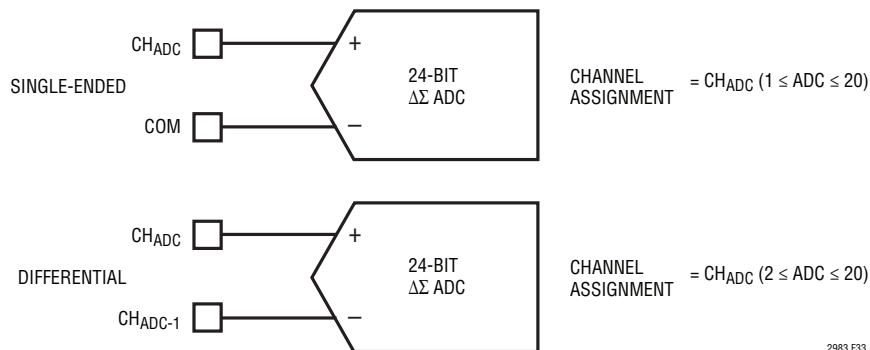

Figure 33. Direct ADC Channel Assignment Conventions

Direct ADC Measurements

In addition to measuring temperature sensors, the LTC2983 can perform direct voltage measurements. Any channel can be configured to perform direct single-ended or differential measurements. Direct ADC channel assignments follow the general convention shown in Figure 33. The 32-bit channel assignment word is programmed into a memory location corresponding to the input channel. The channel assignment word is 0xF000 0000 for differ-

ential readings and 0xF400 0000 for single-ended. The positive input channel ties to CH_{ADC} for both single-ended and differential modes. For single-ended measurements the ADC negative input is COM while for differential measurements it is CH_{ADC-1}. For single ended measurements, COM can be driven with any voltage above GND – 50mV and below V_{DD} – 0.3V.

The direct ADC results are available in memory at a location corresponding to the conversion channel.

Table 63. Direct ADC Output Format

	START ADDRESS								START ADDRESS + 1								START ADDRESS + 2								START ADDRESS + 3 (END ADDRESS)							
	D31	D30	D29	D28	D27	D26	D25	D24	D23	D22	D21	D20	D19	D18	D17	D16	D15	D14	D13	D12	D11	D10	D9	D8	D7	D6	D5	D4	D3	D2	D1	D0
	Fault Data								SIGN MSB								LSB															
Volts	Sensor Hard Fault	Range Hard Fault	NA	NA	Soft Above	Soft Below	Soft Range	Valid Always 1	± 2V 1V 0.5V 0.25V ...																							
									Integer				Fraction																			
>V _{REF}	1	1	0	0	1	0	1		CLAMPED to Factory Programmed Value of V _{REF}																							
1.75 • V _{REF} /2	1	1	0	0	1	0	1	1	0	1	0	0	0	1	1	0	0	0	0	0	0	0	0	0	0	0	0	0	0	0	0	0
1.125 • V _{REF} /2	0	0	0	0	1	0	1	1	0	0	1	0	1	1	0	1	0	0	0	0	0	0	0	0	0	0	0	0	0	0	0	0
V _{REF} /2	0	0	0	0	0	0	0	1	0	0	1	0	1	0	0	0	0	0	0	0	0	0	0	0	0	0	0	0	0	0	0	0
V _{REF} /2 ²²	0	0	0	0	0	0	0	1	0	0	0	0	0	0	0	0	0	0	0	0	0	0	0	0	0	0	0	0	0	0	0	1
0	0	0	0	0	0	0	0	1	0	0	0	0	0	0	0	0	0	0	0	0	0	0	0	0	0	0	0	0	0	0	0	0
-V _{REF} /2 ²²	0	0	0	0	0	0	0	1	1	1	1	1	1	1	1	1	1	1	1	1	1	1	1	1	1	1	1	1	1	1	1	1
-V _{REF} /2	0	0	0	0	0	0	0	1	1	1	0	1	1	0	0	0	0	0	0	0	0	0	0	0	0	0	0	0	0	0	0	0
-1.125 • V _{REF}	0	0	0	0	0	1	1	1	1	1	0	1	0	0	1	1	0	0	0	0	0	0	0	0	0	0	0	0	0	0	0	0
-1.75 • V _{REF}	1	1	0	0	0	1	1	1	1	0	1	1	1	0	1	0	0	0	0	0	0	0	0	0	0	0	0	0	0	0	0	0
<-V _{REF}	1	1	0	0	0	1	1	1	CLAMPED to Factory Programmed Value of -V _{REF}																							

2983fc

SUPPLEMENTAL INFORMATION

The data is represented as a 32-bit word (see Table 63) where the eight most significant bits are fault bits and the bottom 24 are the ADC reading in volts. For direct ADC readings hard fault errors do not clamp the digital output. Readings beyond $\pm 1.125 \cdot V_{REF}/2$ exceed the normal accuracy range of the LTC2983 and flag a soft error; these results should be discarded. Readings beyond $\pm 1.75 \cdot$

$V_{REF}/2$ exceed the usable range of the LTC2983; these result in a hard fault and should be discarded.

Figures 34 to 36 show typical integral nonlinearity variation at various supply voltages and temperatures for a differential input voltage ($\pm V_{REF}/2$) and $V_{REF}/2$ common mode input voltage.

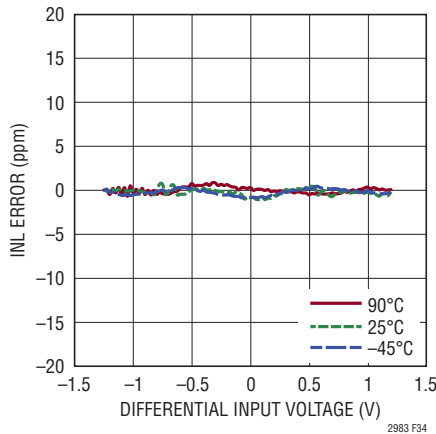

Figure 34. Integral Nonlinearity as a Function of Temperature at $V_{DD} = 5.25V$

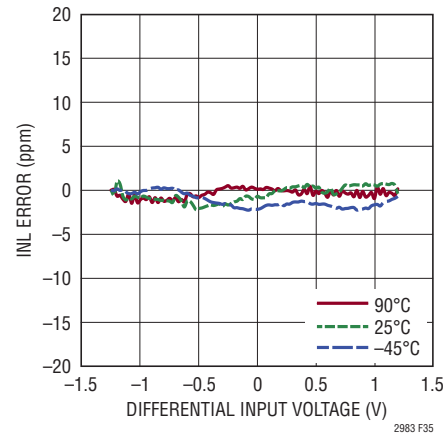

Figure 35. Integral Nonlinearity as a Function of Temperature at $V_{DD} = 3.3V$

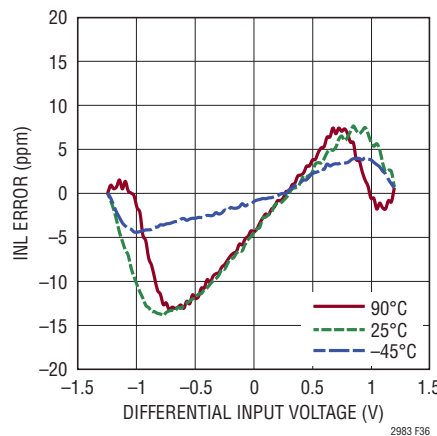

Figure 36. Integral Nonlinearity as a Function of Temperature at $V_{DD} = 2.85V$

SUPPLEMENTAL INFORMATION

Fault Protection and Anti-Aliasing

The LTC2983 analog input channels draw a maximum of 1nA DC. As a result, it is possible to add anti-aliasing and fault protection circuitry directly to the input of the LTC2983. The most common input circuitry is a low pass filter with 1k to 10k resistance (limited by excitation current for RTDs and thermistors) and a capacitor with 100pF-0.1 μ F capacitance. This circuit can be placed directly between the thermocouples and 4-wire RTDs and the LTC2983. In the case of 3-wire RTDs, mismatch errors between the protection resistors can degrade the performance. Thermistors requiring input protection should be tied to the LTC2983 through a Kelvin type connection in order to avoid errors due to the fault protection resistors.

2- and 3-Cycle Conversion Modes

The LTC2983 performs multiple internal conversions in order to determine the sensor temperature. Normally, two internal conversion cycles are required for each temperature result providing a maximum output time of 167.2ms. The LTC2983 uses these two cycles to automatically remove offset/offset drift errors, reduce 1/f noise, auto-calibrate matched internal current sources, and provide simultaneous 50/60Hz noise rejection.

In addition to performing two conversion cycles per result, the LTC2983 also offers several unique features by utilizing a 3rd conversion cycle. In this case, the maximum output time is 251ms and all the benefits of the 2-cycle modes are present (see Table 64).

One feature utilizing the three conversion cycle mode is the internal open circuit detect mode. Typically, thermocouple open circuit detection is performed by adding a high resistance pull-up between the thermocouple and V_{DD} . This method can be used with the LTC2983 while operating in the two conversion cycle mode (OC=0). This external pull-up can interact with the input protection circuitry and lead to temperature measurement errors and increased noise. These problems are eliminated by selecting the internal open circuit detection mode (OC=1). In this case, a current is pulsed for 8ms and allowed to settle during one conversion cycle. This is followed by the normal two

conversion cycle measurement of the thermocouple. If the thermocouple is broken, the current pulse will result in an open circuit fault.

A second feature taking advantage of the 3rd conversion cycle is thermistor excitation current auto ranging. Since a thermistor's resistance varies many orders of magnitude, the performance in the low resistance regions are compromised by the small currents required by the high resistance regions of operation. The auto ranging mode applies a test current during the first conversion cycle in order to determine the optimum current for the resistance state of the thermistor. It then uses that current to perform the thermistor measurement using the normal 2-cycle measurement. If a 3-cycle thermistor measurement is used as the cold junction sensor for a 2-cycle thermocouple measurement, the thermocouple conversion result is ready after three cycles.

A third feature requiring a 3rd conversion cycle is the three current diode measurement. In this mode, three ratioed currents are applied to the external diode in order to cancel parasitic lead resistance effects. This is useful in applications where the diode is remotely located and significant, unknown parasitic lead resistance requires cancellation. If a 3-cycle diode or thermistor measurement is used as the cold junction sensor for a 2-cycle thermocouple measurement, the thermocouple conversion result is ready after three cycles.

Table 64. 2- and 3-Cycles Conversion Modes

TYPE OF SENSOR	CONFIGURATION	NUMBER OF CONVERSION CYCLES	MAXIMUM OUTPUT TIME
Thermocouple	OC = 0	2	167.2ms
RTD	All	2	167.2ms
Thermistor	Non-Autorange Current	2	167.2ms
Diode	Two Readings	2	167.2ms
Thermocouple	OC = 1	3	251ms
Thermocouple	OC = 0, 3-Cycle Cold Junction	3	251ms
Thermistor	Autorange Current	3	251ms
Diode	Three Readings	3	251ms

SUPPLEMENTAL INFORMATION

Running Conversions Consecutively on Multiple Channels

Generally, during the Initiate Conversion state, a conversion measurement is started on a single input channel determined by the channel number (bits B[4:0] = 00001 to 10100) written into memory location 0x000. Multiple consecutive conversions can be initiated by writing bits B[4:0]=00000 into memory location 0. Conversions will be initiated on each channel selected in the mask register (see Table 65).

For example, using the mask data shown in Table 66, after 1000000 is written into memory location 0, conversions are initiated consecutively on CH20, CH19, CH16, and CH1. Once the conversions begin, the INTERRUPT pin goes LOW and remains LOW until all conversions are complete. If the mask register is set for a channel that has no assignment data, that conversion step is skipped. All the results are stored in the conversion result memory locations and can be read at the conclusion of the measurement cycle.

Entering/Exiting Sleep Mode

The LTC2983 can be placed into sleep mode by writing 0x97 to memory location 0x000. On the rising edge of \overline{CS} following the memory write (see Figure 2) the device enters the low power sleep state. It remains in this state until \overline{CS} is brought low or \overline{RESET} is asserted. Once one of these two signals is asserted, the LTC2983 begins its start-up cycle as described in State 1: Start-Up section of this data sheet.

MUX Configuration Delay

The LTC2983 performs 2 or 3 internal conversion cycles per temperature result. Each conversion cycle is performed with different excitation and input multiplexer configurations. Prior to each conversion, these excitation circuits and input switch configurations are changed and an internal 1ms (typical) delay ensures settling prior to the conversion cycle in most cases.

Table 65. Multiple Conversion Mask Register

MEMORY LOCATION	B7	B6	B5	B4	B3	B2	B1	B0
0x0F4		Reserved						
0x0F5					CH20	CH19	CH18	CH17
0x0F6	CH16	CH15	CH14	CH13	CH12	CH11	CH10	CH9
0x0F7	CH8	CH7	CH6	CH5	CH4	CH3	CH2	CH1

Table 66. Example Mask Register Select CH20, CH19, CH16, and CH1

MEMORY LOCATION	B7	B6	B5	B4	B3	B2	B1	B0
0x0F4		Reserved						
0x0F5					1	1	0	0
0x0F6	1	0	0	0	0	0	0	0
0x0F7	0	0	0	0	0	0	0	1

SUPPLEMENTAL INFORMATION

If excessive RC time constants are present in external sensor circuits (large bypass capacitors used for thermistors or RTDs) it is possible to increase the settling time between current source excitation and MUX switching. The extra delay is determined by the value written into the MUX configuration delay register (memory location 0x0FF). The value written into this memory location is multiplied by 100µs; therefore the maximum extra MUX delay is 25.5ms (i.e. 0x0FF = 255 • 100µs).

Global Configuration Register

The LTC2983 includes a global configuration register (memory location 0x0F0, see Figure 37). This register is used to set the notch frequency of the digital filter and temperature results format (°C or °F). The default setting is simultaneous 50/60Hz rejection (75dB rejection with 1ms MUX delay). If higher 60Hz rejection is required (120dB rejection), write 0x01 into memory location 0x0F0; if higher 50Hz rejection is required (120dB rejection) write 0x02 into memory location 0x0F0.

The default temperature units reported by the LTC2983 are °C. The reported temperature can also be output in °F by setting bit 3 of memory location 0x0F0 to 1. All other global configuration bits should be set to 0.

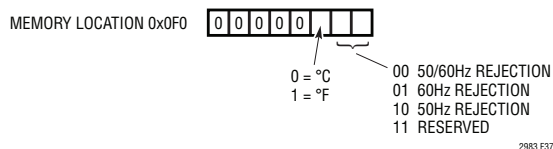

Figure 37. Global Configuration Register

Reference Considerations

The mechanical stress of soldering the LTC2983 to a PC board can cause the output voltage reference to shift and temperature coefficient to change. These two changes are not correlated. For example, the voltage may shift but the temperature coefficient may not. To reduce the effects of stress-related shifts, mount the reference near the short edge of the PC board or in a corner.

CUSTOM THERMOCOUPLES

In addition to digitizing standard thermocouples, the LTC2983 can also digitize user-programmable, custom thermocouples (thermocouple type=0b01001, see Table 12). Custom sensor data (minimum of three, maximum of 64 pairs) reside sequentially in memory and are arranged in blocks of six bytes of monotonically increasing tabular data as mV vs temperature (see Table 67).

Table 67. Custom Thermocouple Tabular Data Format

ADDRESS	BYTE 0	BYTE 1	BYTE 2	BYTE 3	BYTE 4	BYTE 5
0x250 + 6* Start Address	Table Entry #1 (mV)		Table Entry #1 (Kelvin)			
0x250 + 6* Start Address + 6	Table Entry #2 (mV)		Table Entry #2 (Kelvin)			
0x250 + 6* Start Address + 12	Table Entry #3 (mV)		Table Entry #3 (Kelvin)			
Max Address = 0x3CA	Table Entry #64 (mV)		Table Entry #64 (Kelvin)			

Custom Thermocouple Example

In this example, a simplified thermocouple curve is implemented (see Figure 38). Points P1 to P9 represent the normal operating range of the custom thermocouple. Voltage readings above point P9 result in a soft fault and the reported temperature is a linear extrapolation using

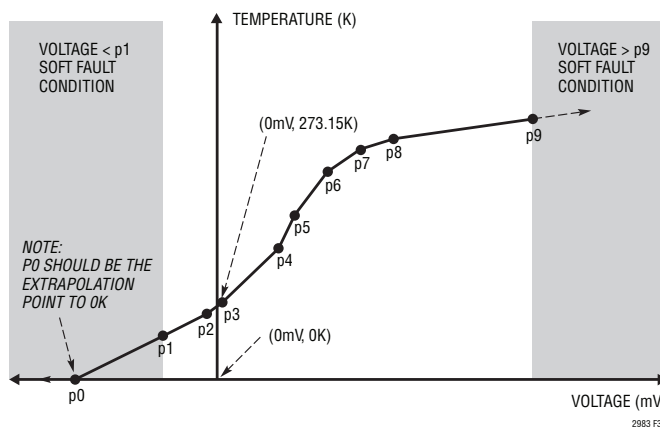

Figure 38. Custom Thermocouple Example (mV vs Kelvin)

CUSTOM THERMOCOUPLES

a slope determined by points P8 and P9 (the final two table entries). Voltage readings below point P1 are also reported as soft faults. The temperature reported is the extrapolation between point P1 and P0, where P0 is typically the sensor output voltage at 0 Kelvin. If P0 is above 0 Kelvin, then all sensor output voltages below P0 (in mV) will report 0 Kelvin.

In order to program the LTC2983 with the custom thermocouple table, both the mV data and the Kelvin data are converted to 24-bit binary values (represented as two 3-byte table entries). Since most thermocouples generate negative output voltages, the mV values input to the LTC2983 are 2's complement. The sensor output voltage (units=mV), follows the convention shown in Table 69, where the first bit is the sign, the next nine are the integer part and the remaining 14 bits are the fractional part.

Table 68. Thermocouple Example mV vs Kelvin (K) Data Memory Map

POINT	SENSOR OUTPUT VOLTAGE (mV)	TEMPERATURE KELVIN	START ADDRESS	STOP ADDRESS	BYTE 0	BYTE 1	BYTE 2	BYTE 3	BYTE 4	BYTE 5
P0	-50.22	0	0x250	0x255						
P1	-30.2	99.1	0x256	0x25B						
P2	-5.3	135.4	0x25C	0x261						
P3	0	273.15	0x262	0x267						
P4	40.2	361.2	0x268	0x26D	mV Data			Temperature Data		
P5	55.3	522.1	0x26E	0x273	(see Table 69)			(see Table 70)		
P6	88.3	720.3	0x274	0x279						
P7	132.2	811.2	0x27A	0x27F						
P8	188.7	922.5	0x280	0x285						
P9	460.4	1000	0x286	0x28B						

Table 69. Example Thermocouple Output Voltage Values (mV)

	BYTE 0								BYTE 1								BYTE 2							
	B23	B22	B21	B20	B19	B18	B17	B16	B15	B14	B13	B12	B11	B10	B9	B8	B7	B6	B5	B4	B3	B2	B1	B0
mV	Sign	2 ⁸	2 ⁷	2 ⁶	2 ⁵	2 ⁴	2 ³	2 ²	2 ¹	2 ⁰	2 ⁻¹	2 ⁻²	2 ⁻³	2 ⁻⁴	2 ⁻⁵	2 ⁻⁶	2 ⁻⁷	2 ⁻⁸	2 ⁻⁹	2 ⁻¹⁰	2 ⁻¹¹	2 ⁻¹²	2 ⁻¹³	2 ⁻¹⁴
-50.22	1	1	1	1	0	0	1	1	0	1	1	1	0	0	0	1	1	1	1	0	1	1	0	0
-30.2	1	1	1	1	1	0	0	0	0	1	1	1	0	0	1	1	0	0	1	1	0	1	0	0
-5.3	1	1	1	1	1	1	1	0	1	0	1	0	1	1	0	0	1	1	0	0	1	1	0	1
0	0	0	0	0	0	0	0	0	0	0	0	0	0	0	0	0	0	0	0	0	0	0	0	0
40.2	0	0	0	0	1	0	1	0	0	0	0	0	1	1	0	0	1	1	0	0	1	1	0	0
55.3	0	0	0	0	1	1	0	1	1	1	0	1	0	0	1	1	0	0	1	1	0	0	1	1
88.3	0	0	0	1	0	1	1	0	0	0	0	1	0	0	1	1	0	0	1	1	0	0	1	1
132.2	0	0	1	0	0	0	0	1	0	0	0	0	1	1	0	0	1	1	0	0	1	1	0	0
188.7	0	0	1	0	1	1	1	1	0	0	1	0	1	1	0	0	1	1	0	0	1	1	0	0
460.4	0	1	1	1	0	0	1	1	0	0	0	1	1	0	0	1	1	0	0	1	1	0	0	1

CUSTOM THERMOCOUPLES

In order to simplify the temperature field, temperature values are input in Kelvin as an unsigned value, but the final temperatures reported by the LTC2983 are reported in °C or °F. The sensor temperature (Kelvin), follows the convention shown in Table 70, where the first 14 bits are the integer part and the remaining 10 bits are the fractional part.

In this example, a custom thermocouple tied to CH1, with a cold junction sensor on CH2, is programmed with the

channel assignment data shown in Table 71 (refer to Figure 6 for similar format). In this case the custom data begins at memory location 0x250 (starting address is 0). The starting address (offset from 0x250) is entered in the custom thermocouple data pointer field of the channel assignment data. The table data length-1 (9 in this example) is entered into the custom thermocouple data length field of the thermocouple channel assignment word. Refer to Table 68 where the number of six byte entries is 10.

Table 70. Example Thermocouple Temperature Values

	BYTE 3							BYTE 4							BYTE 5									
	B23	B22	B21	B20	B19	B18	B17	B16	B15	B14	B13	B12	B11	B10	B9	B8	B7	B6	B5	B4	B3	B2	B1	B0
Temperature	2 ¹³	2 ¹²	2 ¹¹	2 ¹⁰	2 ⁹	2 ⁸	2 ⁷	2 ⁶	2 ⁵	2 ⁴	2 ³	2 ²	2 ¹	2 ⁰	2 ⁻¹	2 ⁻²	2 ⁻³	2 ⁻⁴	2 ⁻⁵	2 ⁻⁶	2 ⁻⁷	2 ⁻⁸	2 ⁻⁹	2 ⁻¹⁰
0	0	0	0	0	0	0	0	0	0	0	0	0	0	0	0	0	0	0	0	0	0	0	0	0
99.1	0	0	0	0	0	0	0	1	1	0	0	0	1	1	0	0	0	1	1	0	0	1	1	0
135.4	0	0	0	0	0	0	1	0	0	0	0	1	1	1	0	1	1	0	0	1	1	0	0	1
273.15	0	0	0	0	0	1	0	0	0	1	0	0	1	0	0	1	0	0	1	1	0	0	1	1
361.2	0	0	0	0	0	1	0	1	1	0	1	0	0	1	0	0	1	1	0	0	1	1	0	0
522.1	0	0	0	0	1	0	0	0	0	0	1	0	1	0	0	0	0	1	1	0	0	1	1	0
720.3	0	0	0	0	1	0	1	1	0	1	0	0	0	0	1	0	0	1	1	0	0	1	1	1
811.2	0	0	0	0	1	1	0	0	1	0	1	0	1	1	0	0	1	1	0	0	1	1	0	0
922.5	0	0	0	0	1	1	1	0	0	1	1	0	1	0	1	0	0	0	0	0	0	0	0	0
1000	0	0	0	0	1	1	1	1	1	0	1	0	0	0	0	0	0	0	0	0	0	0	0	0

Table 71. Custom Thermocouple Channel Assignment Data

CONFIGURATION FIELD	DESCRIPTION	# BITS	BINARY DATA	MEMORY ADDRESS 200	MEMORY ADDRESS 201	MEMORY ADDRESS 202	MEMORY ADDRESS 203																				
(1) Thermocouple Type	Type Custom	5	01001	0	1	0	0	1																			
(2) Cold Junction Channel Pointer	CH ₂	5	00010						0	0	0	1	0														
(3) Sensor Configuration	Single-Ended, 10µA Open Circuit	4	1100									1	1	0	0												
Not Used	Set These Bits to 0	6	000000													0	0	0	0	0	0						
(4) Custom Thermocouple Data Pointer	Start Address = 0 (Start at 0x250)	6	000000														0	0	0	0	0	0					
Custom Thermocouple Data Length-1	Data Length -1 = 9 (10 Paired Entries)	6	001010																			0	0	1	0	0	1

CUSTOM RTDS

In addition to digitizing standard RTDs, the LTC2983 can also digitize custom RTDs (RTD type=0b10010, see Table 26). Custom sensor data (minimum of three, maximum of 64 pairs) reside sequentially in memory and are arranged in blocks of six bytes of monotonically increasing tabular data Ω vs temperature (see Table 72).

Table 72. Custom RTD/Thermistor Tabular Data Format

ADDRESS	BYTE 0	BYTE 1	BYTE 2	BYTE 3	BYTE 4	BYTE 5
0x250 + 6* Start Address	Table Entry #1 (Ω)		Table Entry #1 (Kelvin)			
0x250 + 6* Start Address + 6	Table Entry #2 (Ω)		Table Entry #2 (Kelvin)			
0x250 + 6* Start Address + 12	Table Entry #3 (Ω)		Table Entry #3 (Kelvin)			
•	•		•			
•	•		•			
•	•		•			
•	•		•			
Max Address = 0x3CA	Table Entry #64 (Ω)		Table Entry #64 (Kelvin)			

Custom RTD Example

In this example, a simplified RTD curve is implemented (see Figure 39). Points P1 to P9 represent the normal operating range of the custom RTD. Resistance readings above point P9 result in a soft fault and the reported temperature is a linear extrapolation using a slope determined by points P8 and P9 (the final two table entries). Resistance readings below point P1 are also reported as soft faults. The temperature reported is the extrapolation between point P1 and P0, where P0 is the sensor output temperature at 0 Ω (This point should be 0 Ω for proper interpolation below point p1).

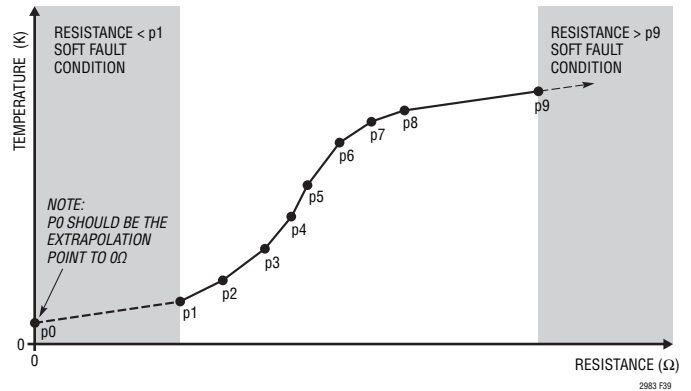

Figure 39. Custom RTD Example (Ω vs Kelvin)

CUSTOM RTDS

Custom RTD table data is formatted in Ω (sensor output resistance) vs Kelvin (see Table 73). Each table entry pair spans six bytes. The first set of data can begin at any memory location greater than or equal to 0x250 and end at or below 0x3CF.

In order to program the LTC2983 with the custom RTD table, both the resistance data and the Kelvin data are converted to 24-bit binary values. The sensor output

resistance (units= Ω) follows the convention shown in Table 74, where the first 13 bits are the integer part and the remaining 11 bits are the fractional part.

In order to simplify the temperature field, temperature values are input in Kelvin as an unsigned value, but the final temperatures reported by the LTC2983 are reported in $^{\circ}\text{C}$ or $^{\circ}\text{F}$. The sensor temperature (Kelvin) follows the

Table 73. RTD Example Resistance vs Kelvin Data Memory Map

POINT	SENSOR OUTPUT RESISTANCE (Ω)	TEMPERATURE (K)	START ADDRESS	STOP ADDRESS	BYTE 1	BYTE 2	BYTE 3	BYTE 1	BYTE 2	BYTE 3
P0	0	112.3	0x28C	0x291						
P1	80	200.56	0x292	0x297						
P2	150	273.16	0x298	0x29D						
P3	257.36	377.25	0x29E	0x2A3						
P4	339.22	489.66	0x2A4	0x2A9	Resistance Data			Temperature Data		
P5	388.26	595.22	0x2AA	0x2AF						
P6	512.99	697.87	0x2B0	0x2B5						
P7	662.3	765.14	0x2B6	0x2BB						
P8	743.5	801.22	0x2BC	0x2C1						
P9	2001.89	900.5	0x2C2	0x2C7						

Table 74. Example RTD Resistance Values

	BYTE 1								BYTE 2								BYTE 3							
	B23	B22	B21	B20	B19	B18	B17	B16	B15	B14	B13	B12	B11	B10	B9	B8	B7	B6	B5	B4	B3	B2	B1	B0
Resistance	2 ¹²	2 ¹¹	2 ¹⁰	2 ⁹	2 ⁸	2 ⁷	2 ⁶	2 ⁵	2 ⁴	2 ³	2 ²	2 ¹	2 ⁰	2 ⁻¹	2 ⁻²	2 ⁻³	2 ⁻⁴	2 ⁻⁵	2 ⁻⁶	2 ⁻⁷	2 ⁻⁸	2 ⁻⁹	2 ⁻¹⁰	2 ⁻¹¹
0	0	0	0	0	0	0	0	0	0	0	0	0	0	0	0	0	0	0	0	0	0	0	0	0
80	0	0	0	0	0	0	1	0	1	0	0	0	0	0	0	0	0	0	0	0	0	0	0	0
150	0	0	0	0	0	1	0	0	1	0	1	1	0	0	0	0	0	0	0	0	0	0	0	0
257.36	0	0	0	0	1	0	0	0	0	0	0	0	1	0	1	0	1	1	1	0	0	0	0	1
339.22	0	0	0	0	1	0	1	0	1	0	0	1	1	0	0	1	1	1	0	0	0	0	1	0
388.26	0	0	0	0	1	1	0	0	0	0	1	0	0	0	1	0	0	0	0	1	0	1	0	0
512.99	0	0	0	1	0	0	0	0	0	0	0	0	0	1	1	1	1	1	1	0	1	0	1	1
662.3	0	0	0	1	0	1	0	0	1	0	1	1	0	0	1	0	0	1	1	0	0	1	1	0
743.5	0	0	0	1	0	1	1	1	0	0	1	1	1	1	0	0	0	0	0	0	0	0	0	0
2001.89	0	0	1	1	1	1	1	0	1	0	0	0	1	1	1	1	0	0	0	1	1	1	1	0

CUSTOM RTDS

convention shown in Table 75, where the first 14 bits are the integer part and the remaining 10 bits are the fractional part.

In this example, a custom RTD tied to CH12/13, with a sense resistor on CH10/11, is programmed with the channel assignment data shown in Table 76 (refer to Figure 15 for a similar format). In this case, the custom data begins

at memory location 0x28C (starting address is 10). The starting address (offset from 0x250) is entered in the custom RTD data pointer field of the channel assignment data. The table data length -1 (9 in this case) is entered into the custom RTD data length field of the channel assignment word. Refer to Table 72 where the total number of paired entries is 10.

Table 75. Example RTD Temperature Values

	BYTE 1							BYTE 2							BYTE 3									
	B23	B22	B21	B20	B19	B18	B17	B16	B15	B14	B13	B12	B11	B10	B9	B8	B7	B6	B5	B4	B3	B2	B1	B0
Temperature	2 ¹³	2 ¹²	2 ¹¹	2 ¹⁰	2 ⁹	2 ⁸	2 ⁷	2 ⁶	2 ⁵	2 ⁴	2 ³	2 ²	2 ¹	2 ⁰	2 ⁻¹	2 ⁻²	2 ⁻³	2 ⁻⁴	2 ⁻⁵	2 ⁻⁶	2 ⁻⁷	2 ⁻⁸	2 ⁻⁹	2 ⁻¹⁰
112.3	0	0	0	0	0	0	0	1	1	1	0	0	0	0	1	0	0	1	1	0	0	1	1	
200.56	0	0	0	0	0	0	1	1	0	0	1	0	0	0	1	0	0	0	1	1	1	1	0	1
273.16	0	0	0	0	0	0	1	0	0	1	0	0	0	1	0	0	1	0	1	0	0	0	1	1
377.25	0	0	0	0	0	0	1	1	1	1	1	0	0	1	0	1	0	0	0	0	0	0	0	0
489.66	0	0	0	0	0	0	0	1	1	0	1	0	0	1	1	0	1	0	1	0	0	0	1	1
595.22	0	0	0	0	1	0	0	1	0	1	0	0	1	1	0	0	1	1	1	0	0	0	0	1
697.87	0	0	0	0	1	0	1	0	1	1	1	0	0	1	1	1	0	1	1	1	1	0	1	0
765.14	0	0	0	0	1	1	0	1	1	1	1	1	0	1	0	0	1	0	0	0	1	1	1	1
801.22	0	0	0	0	1	0	1	0	1	0	0	0	0	1	0	0	1	1	1	0	0	0	0	1
900.5	0	0	0	0	1	1	1	0	0	0	0	1	0	0	1	0	0	0	0	0	0	0	0	0

Table 76. Custom RTD Channel Assignment Data

CONFIGURATION FIELD	DESCRIPTION	# BITS	BINARY DATA	MEMORY ADDRESS 230	MEMORY ADDRESS 231	MEMORY ADDRESS 232	MEMORY ADDRESS 233																	
(1) RTD Type	Custom	5	10010	1	0	0	1	0																
(2) Sense Resistor Channel Pointer	CH ₁₁	5	01011						0	1	0	1	1											
(3) Sensor Configuration	4-Wire, No Rotate, No Share	4	1000											1	0	0	0							
(4) Excitation Current	25µA	4	0011																					
(5) Curve	Not Used for Custom	2	00																					
(6) Custom RTD Data Pointer	Start Address = 10	6	001010																					
(6) Custom RTD Data Length-1	Data Length -1 = 9 10 Paired Entries	6	001001																					

CUSTOM THERMISTORS

In addition to digitizing standard thermistors, the LTC2983 can also digitize custom thermistors (thermistor type=0b11011, see Table 51). Custom sensor data (minimum of three, maximum of 64 pairs) reside sequentially in memory and are arranged in blocks of six bytes of monotonically increasing tabular data Ω vs temperature (see Table 72).

Custom Thermistor Table Example

In this example, a simplified thermistor NTC (negative temperature coefficient) curve is implemented (see Figure 40). Points P1 to P9 represent the normal operating range of the custom thermistor. Resistance readings above point P9 result in a soft fault and the reported temperature is a linear extrapolation using a slope determined by points P8 and P9 (the final two table entries). Resistance readings below point P1 are also reported as soft faults. The temperature reported is the extrapolation between point P1 and P0, where P0 is the sensor output temperature at 0Ω (This point must be 0Ω for proper interpolation below point p1).

P9 result in a soft fault and the reported temperature is a linear extrapolation using a slope determined by points P8 and P9 (the final two table entries). Resistance readings below point P1 are also reported as soft faults. The temperature reported is the extrapolation between point P1 and P0, where P0 is the sensor output temperature at 0Ω (This point must be 0Ω for proper interpolation below point p1).

In addition to NTC type thermistors, it is also possible to implement PTC (positive temperature coefficient) type thermistors (see Figure 41). In both cases, table entries start at the minimum resistance and end at the maximum resistance value.

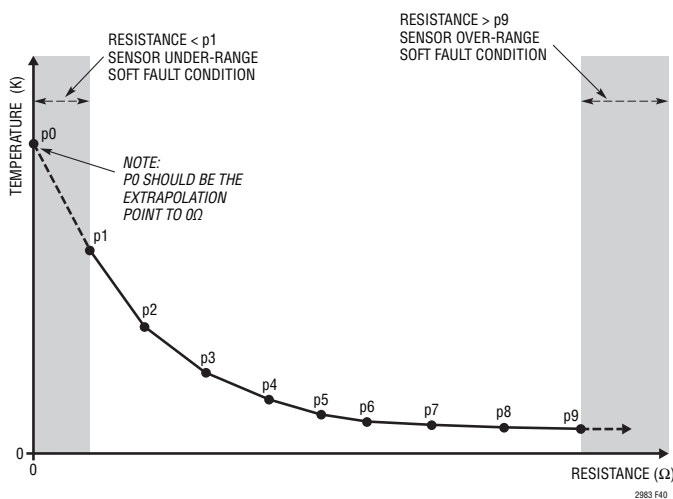

Figure 40. Custom NTC Thermistor Example (Ω vs Kelvin)

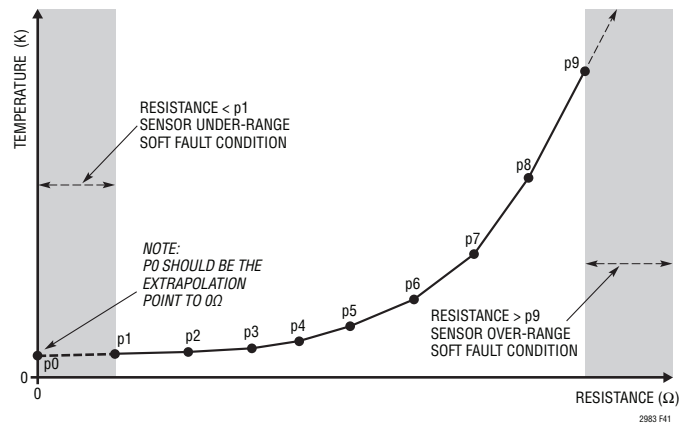

Figure 41. Custom PTC Thermistor Example (Ω vs Kelvin)

CUSTOM THERMISTORS

Custom thermistor table data is formatted in Ω (sensor output resistance) vs Kelvin (see Table 77). Each table entry pair spans six bytes. The first set of data can begin at any memory location greater than or equal to 0x250 and end below 0x3CF.

In order to program the LTC2983 with the custom thermistor table, both the resistance data and the Kelvin data are converted to 24-bit binary values. The sensor output resistance (units= Ω) follows the convention shown in

Table 78, where the first 20 bits are the integer part and the remaining four bits are the fractional part.

In order to simplify the temperature field, temperature values are input in Kelvin as an unsigned value, but the final temperatures reported by the LTC2983 are reported in $^{\circ}\text{C}$ or $^{\circ}\text{F}$. The sensor temperature (Kelvin) follows the convention shown in Table 79, where the first 14 bits are the integer part and the remaining 10 bits are the fractional part.

Table 77. NTC Thermistor Example Resistance vs Kelvin Data Memory Map

POINT	SENSOR OUTPUT RESISTANCE(Ω)	TEMPERATURE (K)	START ADDRESS	STOP ADDRESS	BYTE 1	BYTE 2	BYTE 3	BYTE 1	BYTE 2	BYTE 3
P0	0	457.5	0x2C8	0x2CD						
P1	80	400.2	0x2CE	0x2D3						
P2	184	372.3	0x2D4	0x2D9						
P3	423.2	320.1	0x2DA	0x2DF						
P4	973.36	290.55	0x2E0	0x2E5	Resistance Data			Temperature Data		
P5	2238.728	249.32	0x2E6	0x2EB						
P6	5149.0744	240.3	0x2EC	0x2F1						
P7	26775.18688	230	0x2F2	0x2F7						
P8	139230.9718	215.3	0x2F8	0x2FD						
P9	724001.0532	200	0x2FE	0x303						

Table 78. Example Thermistor Resistance Values

Resistance	BYTE 1								BYTE 2								BYTE 3							
	B23	B22	B21	B20	B19	B18	B17	B16	B15	B14	B13	B12	B11	B10	B9	B8	B7	B6	B5	B4	B3	B2	B1	B0
0	0	0	0	0	0	0	0	0	0	0	0	0	0	0	0	0	0	0	0	0	0	0	0	0
80	0	0	0	0	0	0	0	0	0	0	0	0	0	1	0	1	0	0	0	0	0	0	0	0
184	0	0	0	0	0	0	0	0	0	0	0	0	1	0	1	1	1	0	0	0	0	0	0	0
423.2	0	0	0	0	0	0	0	0	0	0	0	1	1	0	1	0	0	1	1	1	0	0	1	1
973.36	0	0	0	0	0	0	0	0	0	0	1	1	1	1	0	0	1	1	0	1	0	1	0	1
2238.728	0	0	0	0	0	0	0	0	1	0	0	0	1	0	1	1	1	1	1	0	1	0	1	1
5149.074	0	0	0	0	0	0	0	1	0	1	0	0	0	0	1	1	1	1	0	1	0	0	0	1
26775.19	0	0	0	0	0	1	1	0	1	0	0	0	1	0	0	1	0	1	1	1	0	0	1	1
139231	0	0	1	0	0	0	0	1	1	1	1	1	1	1	0	1	1	1	1	1	0	0	0	0
724001.1	1	0	1	1	0	0	0	0	1	1	0	0	0	0	1	0	0	0	0	1	0	0	0	1

CUSTOM THERMISTORS

In this example, a custom thermistor tied to CH5, with a sense resistor on CH3/4, is programmed with the channel assignment data shown in Table 80 (refer to Figure 24 for similar format). In this case the custom data begins at memory location 0x2C8 (starting address is 20). The

starting address (offset from 0x250) is entered in the custom thermistor data pointer field of the channel assignment data. The table data length -1 (9 in this case) is entered into the custom thermistor data length field of the thermistor channel assignment word.

Table 79. Example Thermistor Temperature Values

	BYTE 1								BYTE 2								BYTE 3							
	B23	B22	B21	B20	B19	B18	B17	B16	B15	B14	B13	B12	B11	B10	B9	B8	B7	B6	B5	B4	B3	B2	B1	B0
Temperature	2 ¹³	2 ¹²	2 ¹¹	2 ¹⁰	2 ⁹	2 ⁸	2 ⁷	2 ⁶	2 ⁵	2 ⁴	2 ³	2 ²	2 ¹	2 ⁰	2 ⁻¹	2 ⁻²	2 ⁻³	2 ⁻⁴	2 ⁻⁵	2 ⁻⁶	2 ⁻⁷	2 ⁻⁸	2 ⁻⁹	2 ⁻¹⁰
457.5	0	0	0	0	0	1	1	1	0	0	1	0	0	1	1	0	0	0	0	0	0	0	0	0
400.2	0	0	0	0	0	1	1	0	0	1	0	0	0	0	0	0	1	1	0	0	1	1	0	0
372.3	0	0	0	0	0	1	0	1	1	1	0	1	0	0	0	1	0	0	1	1	0	0	1	1
320.1	0	0	0	0	0	1	0	1	0	0	0	0	0	0	0	0	0	1	1	0	0	1	1	0
290.55	0	0	0	0	0	1	0	0	1	0	0	0	1	0	1	0	0	0	1	1	0	0	1	1
249.32	0	0	0	0	0	0	1	1	1	1	1	0	0	1	0	1	0	1	0	0	0	1	1	1
240.3	0	0	0	0	0	0	1	1	1	1	0	0	0	0	1	0	0	1	1	0	0	1	1	1
230	0	0	0	0	0	0	1	1	1	0	0	1	1	0	0	0	0	0	0	0	0	0	0	0
215.3	0	0	0	0	0	0	1	1	0	1	0	1	1	1	0	1	0	0	1	1	0	0	1	1
200	0	0	0	0	0	0	1	1	0	0	1	0	0	0	0	0	0	0	0	0	0	0	0	0

Table 80. Custom Thermistor Channel Assignment Data

CONFIGURATION FIELD	DESCRIPTION	# BITS	BINARY DATA	MEMORY ADDRESS 210	MEMORY ADDRESS 211	MEMORY ADDRESS 212	MEMORY ADDRESS 213																					
(1) Thermistor Type	Custom Table	5	11011	1	1	0	1	1																				
(2) Sense Resistor Channel Pointer	CH ₄	5	00100					0	0	1	0	0																
(3) Sensor Configuration	Single-Ended	3	100									1	0	0														
(4) Excitation Current	1μA	4	0011												0	0	1	1										
Not Used	Set These Bits to 0	3	00															0	0	0								
(5) Custom Thermistor Data Pointer	Start Address = 20	6	010100																	0	1	0	1	0	0			
(5) Custom Thermistor Length-1	Length -1 = 9	6	001001																				0	0	1	0	0	1

CUSTOM THERMISTORS

In addition to custom table driven thermistors, it is also possible to directly input Steinhart-Hart coefficients into the LTC2983 (thermistor type 11010, see Table 51). Steinhart-Hart coefficients are commonly specified parameters provided by thermistor manufacturers. The Steinhart-Hart equation is:

$$\frac{1}{T} = A + B \cdot \ln(R) + C \cdot \ln(R)^2 + D \cdot \ln(R)^3 + E \cdot \ln(R)^4 + F \cdot \ln(R)^5$$

Steinhart-Hart data is stored sequentially in any memory location greater than or equal to 0x250 and below 0x3CF. Each coefficient is represented by a standard, single-precision, IEEE754 32-bit value (see Table 81).

Example Custom Steinhart-Hart Thermistor

In this example a Steinhart-Hart equation is entered into memory starting at location 0x300 (see Table 82).

Table 81. Steinhart-Hart Custom Thermistor Data Format

ADDRESS	COEFFICIENT	VALUE
0x250 + 4 * Start Address	A	32-Bit Single-Precision Floating Point Format
0x250 + 4 * Start Address + 4	B	32-Bit Single-Precision Floating Point Format
0x250 + 4 * Start Address + 8	C	32-Bit Single-Precision Floating Point Format
0x250 + 4 * Start Address + 12	D	32-Bit Single-Precision Floating Point Format
0x250 + 4 * Start Address + 16	E	32-Bit Single-Precision Floating Point Format
0x250 + 4 * Start Address + 20	F	32-Bit Single-Precision Floating Point Format

Table 82. Custom Steinhart-Hart Data Example

COEFFICIENT	VALUE	START ADDRESS	SIGN	EXPONENT								MANTISSA																							
				MSB				LSB				MSB												LSB											
A	1.45E-03	0x300	0	0	1	1	1	0	1	0	1	0	1	1	1	1	1	0	0	0	0	0	1	1	0	1	1	1	1	0	1	1	0	1	
B	2.68E-04	0x304	0	0	1	1	1	0	0	1	1	0	0	0	1	1	0	0	1	0	0	0	0	0	1	0	0	1	0	1	1	0	1	0	
C	0	0x308	0	0	0	0	0	0	0	0	0	0	0	0	0	0	0	0	0	0	0	0	0	0	0	0	0	0	0	0	0	0	0		
D	1.64E-07	0x30C	0	0	1	1	0	1	0	0	0	0	1	1	0	0	0	0	0	0	1	0	1	1	1	1	1	1	1	1	1	0	1	0	
E	0	0x310	0	0	0	0	0	0	0	0	0	0	0	0	0	0	0	0	0	0	0	0	0	0	0	0	0	0	0	0	0	0	0		
F	0	0x314	0	0	0	0	0	0	0	0	0	0	0	0	0	0	0	0	0	0	0	0	0	0	0	0	0	0	0	0	0	0	0		

CUSTOM THERMISTORS

Table 83. Custom Steinhart-Hart Channel Assignment Data

CONFIGURATION FIELD	DESCRIPTION	# BITS	BINARY DATA	MEMORY ADDRESS 210	MEMORY ADDRESS 211	MEMORY ADDRESS 212	MEMORY ADDRESS 213
(1) Thermistor Type	Custom Steinhart-Hart	5	11010	1 1 0 1 0			
(2) Sense Resistor Channel Pointer	CH ₄	5	00100		0 0 1 0 0		
(3) Sensor Configuration	Single-Ended	3	100		1 0 0		
(4) Excitation Current	1 μ A	4	0011			0 0 1 1	
Not Used	Set These Bits to 0	3	00			0 0 0	
(5) Custom Thermistor Data Pointer	Start Address = 30	6	011110				0 1 1 1 1 0
(5) Custom Steinhart-Hart Length Always Set to 0	Fixed at Six 32-Bit Words	6	000000				0 0 0 0 0 0

A custom thermistor tied to CH5, with a sense resistor on CH3/4, is programmed with the channel assignment data shown in Table 83 (refer to Figure 24 for a similar format). In this case the custom data begins at memory location 0x26E (starting address is 30). The starting address (offset from 0x250) is entered in the custom thermistor data pointer field of the channel assignment data. The data length (set to 0) is always six 32-bit floating point words.

Universal Sensor Hardware

The LTC2983 can be configured as a universal temperature measurement device. Up to four sets of universal inputs can be applied to a single LTC2983. Each of these sets can directly digitize a 3-wire RTD, 4-Wire RTD, Thermistor, or thermocouple without changing any on board hardware (see Figure 42). Each sensor can share the same four ADC inputs and protection/filtering circuitry are configured using software changes (new channel assignment data) only. One sense resistor and cold junction sensor are shared among all four banks of sensors.

The LTC2983 includes many flexible, software configurable input modes. In order to share four common inputs among all four sensor types each sensor requires specific configuration bits (see Table 84). 3-Wire RTDs are configured with shared R_{SENSE}, 4-Wire RTDs and thermistors are configured as shared and/or rotated, thermocouples are configured differential with internal ground, and diodes are configured as single-ended.

Table 84. Sensor Configuration for Universal Hookup

SENSOR TYPE	CONFIGURATION OPTIONS	CONFIGURATION BITS	SEE TABLE
3-WIRE RTD	Share	B18 = 1, B19 = 0	Table 28
4-WIRE RTD	Share	B18 = 1, B19 = 0	Table 28
4-WIRE RTD	Rotate	B18 = 0, B19 = 1	Table 28
Thermistor	Share	B19 = 0, B20 = 1	Table 52
Thermistor	Rotate	B19 = 1, B20 = 0	Table 52
Thermocouple	Single-Ended	B21 = 1	Table 14
Diode	Single-Ended	B26 = 1	Table 17

PACKAGE DESCRIPTION

Please refer to <http://www.linear.com/product/LTC2938#packaging> for the most recent package drawings.

LX Package
48-Lead Plastic LQFP (7mm × 7mm)
 (Reference LTC DWG # 05-08-1760 Rev A)

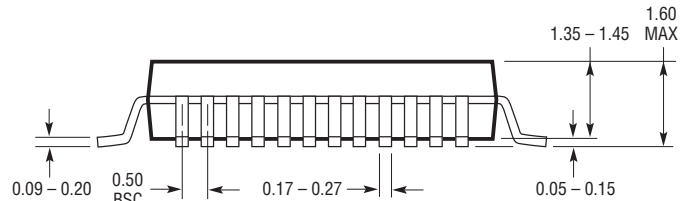
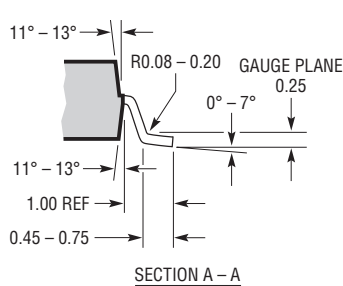
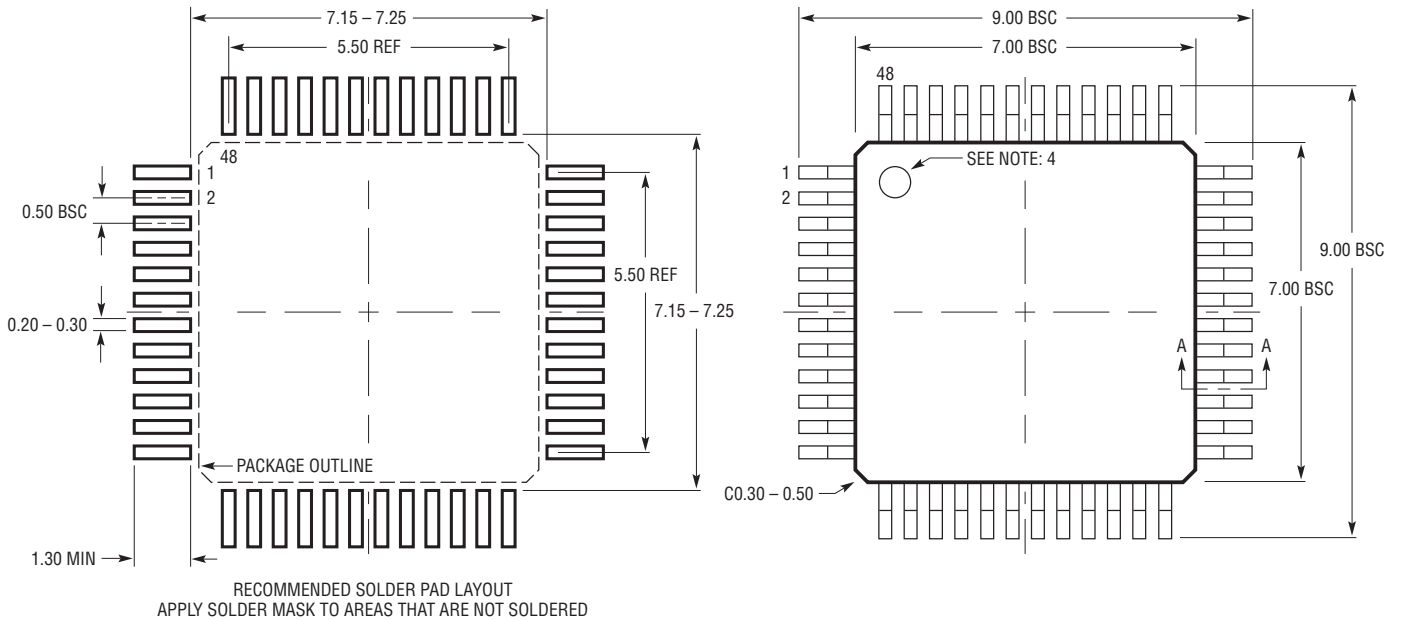

- NOTE:
1. PACKAGE DIMENSIONS CONFORM TO JEDEC #MS-026 PACKAGE OUTLINE
 2. DIMENSIONS ARE IN MILLIMETERS
 3. DIMENSIONS OF PACKAGE DO NOT INCLUDE MOLD FLASH. MOLD FLASH SHALL NOT EXCEED 0.25mm ON ANY SIDE, IF PRESENT
 4. PIN-1 IDENTIFIER IS A MOLDED INDENTATION, 0.50mm DIAMETER
 5. DRAWING IS NOT TO SCALE

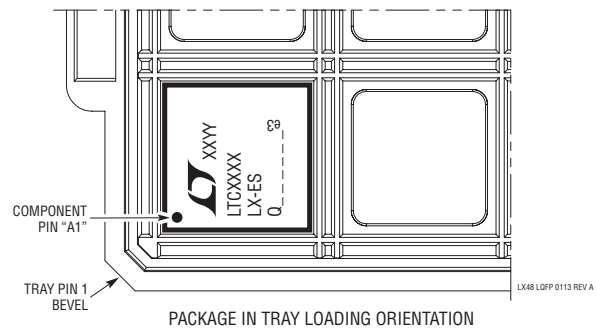

REVISION HISTORY

REV	DATE	DESCRIPTION	PAGE NUMBER
A	07/15	Removed Tape and Reel options	3
		Added Absolute Maximum Ratings for Q ₁ , Q ₂ , Q ₃ , LDO, V _{REFOUT} , V _{REF_BYP}	3
		Changed reference Output Voltage Temperature Coefficient	4
		Changed Error Contribution for thermocouples	13
		Changed filter capacitor values in Figures 9, 12, 15, 18, 19, 21	33, 35, 37, 39, 40, 42
B	09/15	Revised Table 2A. Memory Map	14
		Revised the following tables so that all bytes contain eight bits: Table 69, 70, 74, 75, 78, 79	60, 61, 63, 64, 66, 67
C	01/16	Added H-Grade option	3, 4

TYPICAL APPLICATION

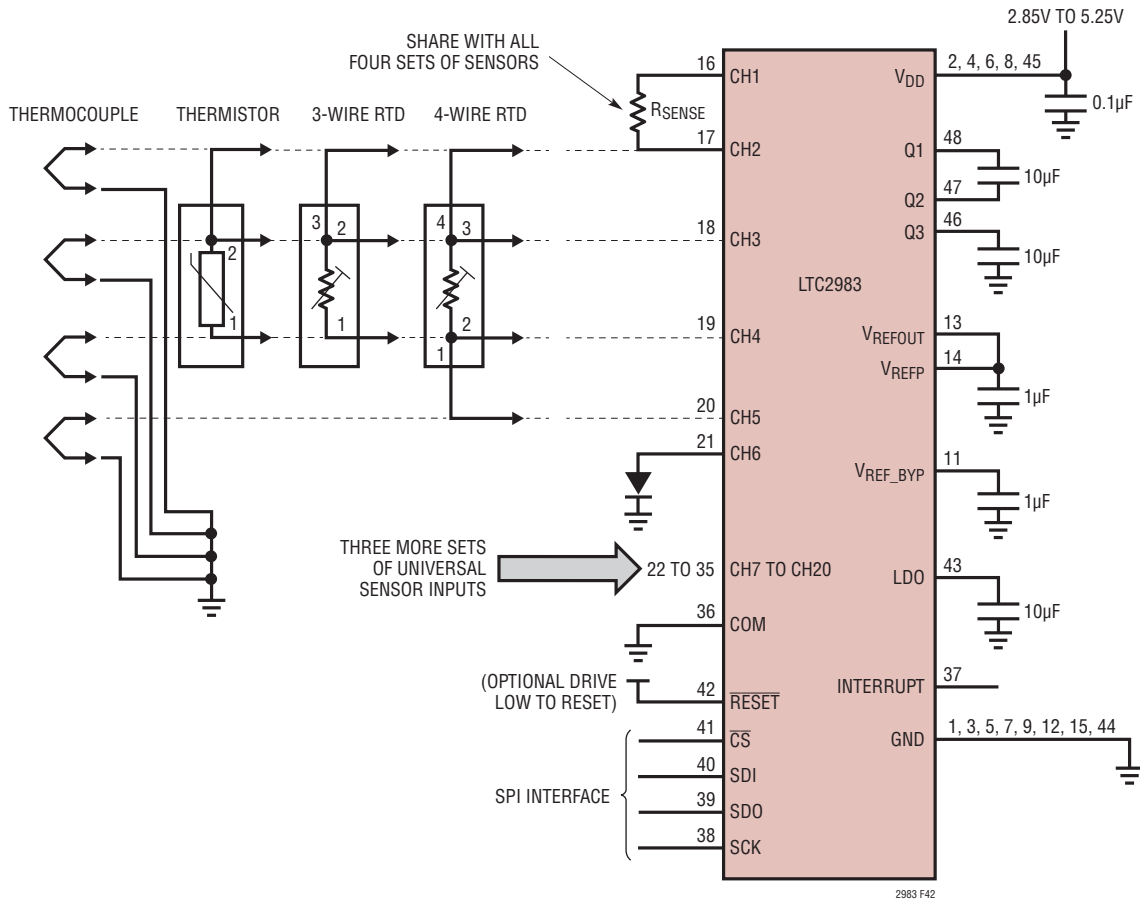

Figure 42. Universal Inputs Allow Common Hardware Sharing for Thermocouples, Diodes, Thermistors, 3-Wire RTDs, and 4-Wire RTDs

RELATED PARTS

PART NUMBER	DESCRIPTION	COMMENTS
LTC2984	Multi-Sensor High Accuracy Digital Temperature Measurement System with EEPROM	Pin/Software Compatible Version of LTC2983 with Integrated EEPROM
LTC2990	Quad I ² C Temperature, Voltage and Current Monitor	Remote and Internal Temperatures, 14-Bit Voltages and Current, Internal 10ppm/°C Reference
LTC2991	Octal I ² C Voltage, Current, Temperature Monitor	Remote and Internal Temperatures, 14-Bit Voltages and Current, Internal 10ppm/°C Reference
LTC2995	Temperature Sensor and Voltage Monitor with Alert Outputs	Monitors Temperature and Two Voltages, Adjustable Thresholds, Open Drain Alert Outputs, Temperature to Voltage Output with Integrated 1.8V Reference, ±1°C (Max) Accuracy
LTC2996	Temperature Sensor with Alert Outputs	Monitors Temperature, Adjustable Thresholds, Open Drain Alert Outputs, Temperature to Voltage Output with Integrated 1.8V Reference, ±1°C (Max) Accuracy
LTC2997	Remote/Internal Temperature Sensor	Temperature to Voltage Output with Integrated 1.8V Reference, ±1°C (Max) Accuracy
LTC2943	20V I ² C Coulomb Counter	Monitors Charge, Current, Voltage and Temperature with 1% Accuracy. Works with Any Battery Chemistry and Capacity