

FEATURES

POWER MANAGER

- High Efficiency Switching PowerPath™ Controller with Bat-Track™ Adaptive Output Control
- Programmable USB or Wall Input Current Limit (100mA/500mA/1A)
- Full Featured Li-Ion/Polymer Battery Charger
- Instant-On Operation with Discharged Battery
- 1.5A Maximum Charge Current
- Internal 180mΩ Ideal Diode Plus External Ideal Diode Controller Powers Load in Battery Mode
- Low No-Load I_Q when Powered from BAT (<30μA)

1A BUCK-BOOST DC/DC

- High Efficiency (1A I_{OUT})
- 2.25MHz Constant Frequency Operation
- Low No-Load Quiescent Current (~13μA)
- Zero Shutdown Current
- Pin Control of All Functions

APPLICATIONS

- HDD Based MP3 Players, PDA, GPS, PMP Products
- Other USB Based Handheld Products

DESCRIPTION

The LTC®3566 family are highly integrated power management and battery charger ICs for Li-Ion/Polymer battery applications. They include a high efficiency current limited switching PowerPath manager with automatic load prioritization, a battery charger, an ideal diode, and a high efficiency synchronous buck-boost switching regulator. Designed specifically for USB applications, the LTC3566 family's switching power manager automatically limits input current to a maximum of either 100mA or 500mA for USB applications or 1A for adapter-powered applications.

The LTC3566 family's switching input stage transmits nearly all of the 2.5W available from the USB port to the system load with minimal power wasted as heat. This feature allows the LTC3566 family to provide more power to the application and eases the constraint of thermal budgeting in small spaces. The LTC3566-2 automatically reduces charge current to maintain a regulated 3.6V V_{OUT} during low battery conditions; the LTC3566 does not. The synchronous buck-boost DC/DC can provide up to 1A.

The LTC3566 family is available in a low profile 24-lead 4mm × 4mm QFN surface mount package.

LT, LT, LTC and LTM are registered trademarks of Linear Technology Corporation. PowerPath and Bat-Track are trademarks of Linear Technology Corporation. All other trademarks are the property of their respective owners. Protected by U.S. Patents including 6522118, 6404251.

TYPICAL APPLICATION

LTC3566/LTC3566-2 USB Power Manager with 3.3V/1A Buck-Boost

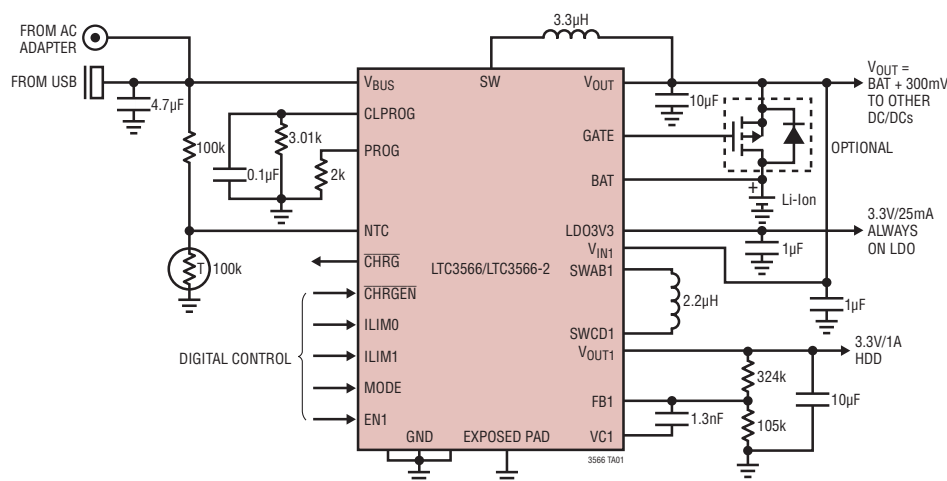

Switching Regulator Efficiency to System Load (P_{OUT}/P_{BUS})

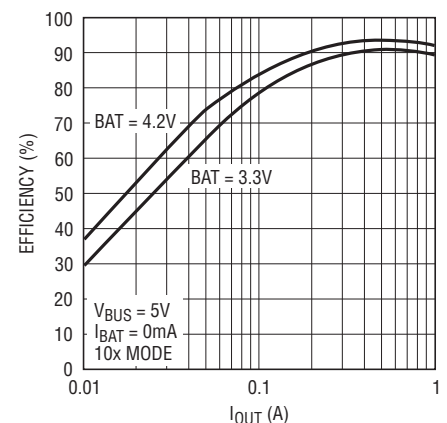

3566 TA01b
 3566fb

ABSOLUTE MAXIMUM RATINGS

(Note 1)

| | |
|---|--|
| V_{BUS} (Transient) $t < 1\text{ms}$, Duty Cycle $< 1\%$ | -0.3V to 7V |
| V_{BUS} (Static), V_{IN1} , BAT, NTC, $\overline{\text{CHRG}}$, MODE, I_{LIM0} , I_{LIM1} , EN1, $\overline{\text{CHRGEN}}$ | -0.3V to 6V |
| FB1, V_{C1} | -0.3V to Lesser of 6V or ($V_{IN1} + 0.3\text{V}$) |
| I_{CLPROG} | 3mA |
| $I_{\overline{\text{CHRG}}}$ | 50mA |
| I_{PROG} | 2mA |
| I_{LDO3V3} | 30mA |
| I_{SW} , I_{BAT} , I_{VOUT} | 2A |
| I_{VOUT1} , I_{SWAB1} , I_{SWCD1} | 2.5A |
| Operating Temperature Range (Note 2).... | -40°C to 85°C |
| Junction Temperature (Note 3) | 125°C |
| Storage Temperature Range..... | -65°C to 125°C |

PIN CONFIGURATION

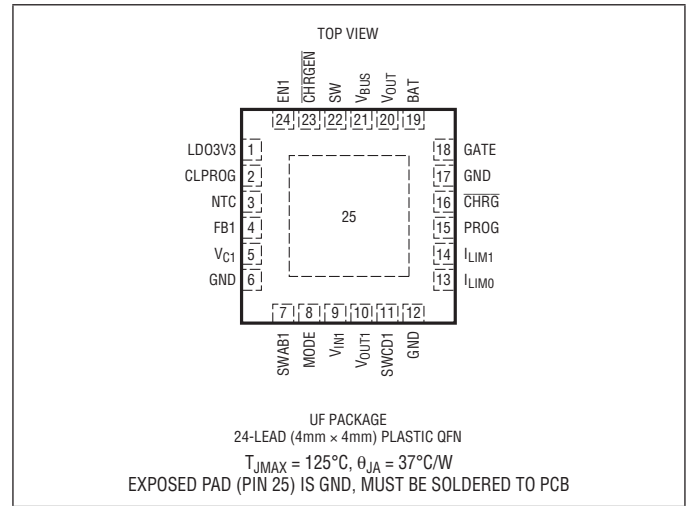

ORDER INFORMATION

| LEAD FREE FINISH | TAPE AND REEL | PART MARKING | PACKAGE DESCRIPTION | TEMPERATURE RANGE |
|------------------|--------------------|--------------|---------------------------------|-------------------|
| LTC3566EUF#PBF | LTC3566EUF#TRPBF | 3566 | 24-Lead (4mm x 4mm) Plastic QFN | -40°C to 85°C |
| LTC3566EUF-2#PBF | LTC3566EUF-2#TRPBF | 35662 | 24-Lead (4mm x 4mm) Plastic QFN | -40°C to 85°C |

Consult LTC Marketing for parts specified with wider operating temperature ranges.

Consult LTC Marketing for information on non-standard lead based finish parts.

For more information on lead free part marking, go to: <http://www.linear.com/leadfree/>

For more information on tape and reel specifications, go to: <http://www.linear.com/tapeandreeel/>

ELECTRICAL CHARACTERISTICS The ● denotes the specifications which apply over the full operating temperature range, otherwise specifications are at $T_A = 25^{\circ}\text{C}$. $V_{BUS} = 5\text{V}$, $V_{BAT} = 3.8\text{V}$, $DV_{CC} = 3.3\text{V}$, $R_{CLPROG} = 3.01\text{k}$, $R_{PROG} = 1\text{k}$, $V_{IN1} = V_{OUT1} = 3.8\text{V}$ unless otherwise noted.

| SYMBOL | PARAMETER | CONDITIONS | MIN | TYP | MAX | UNITS | |
|---------------------------------------|---|--|------------------|--------------------------|-----------------------------|----------------------------|----------------------------------|
| Power Path Switching Regulator | | | | | | | |
| V_{BUS} | Input Supply Voltage | | 4.35 | | 5.5 | V | |
| I_{BUSLIM} | Total Input Current | 1x Mode, $V_{OUT} = \text{BAT}$ 5x Mode, $V_{OUT} = \text{BAT}$ 10x Mode, $V_{OUT} = \text{BAT}$ Suspend Mode, $V_{OUT} = \text{BAT}$ | ● ● ● ● | 87 436 800 0.31 | 95 460 860 0.38 | 100 500 1000 0.50 | mA mA mA mA |
| I_{BUSQ} | V_{BUS} Quiescent Current | 1x Mode, $I_{OUT} = 0\text{mA}$ 5x Mode, $I_{OUT} = 0\text{mA}$ 10x Mode, $I_{OUT} = 0\text{mA}$ Suspend Mode, $I_{OUT} = 0\text{mA}$ | | | 7 15 15 0.044 | | mA mA mA mA |
| h_{CLPROG} (Note 4) | Ratio of Measured V_{BUS} Current to CLPROG Program Current | 1x Mode 5x Mode 10x Mode Suspend Mode | | | 224 1133 2140 11.3 | | mA/mA mA/mA mA/mA mA/mA |

ELECTRICAL CHARACTERISTICS The ● denotes the specifications which apply over the full operating temperature range, otherwise specifications are at $T_A = 25^\circ\text{C}$. $V_{\text{BUS}} = 5\text{V}$, $V_{\text{BAT}} = 3.8\text{V}$, $DV_{\text{CC}} = 3.3\text{V}$, $R_{\text{CLPROG}} = 3.01\text{k}$, $R_{\text{PROG}} = 1\text{k}$, $V_{\text{IN1}} = V_{\text{OUT1}} = 3.8\text{V}$ unless otherwise noted.

| SYMBOL | PARAMETER | CONDITIONS | MIN | TYP | MAX | UNITS |
|--|---|---|------------------|----------------------------|----------------|---|
| I_{OUT} (PowerPath) | V_{OUT} Current Available Before Loading BAT | 1x Mode, BAT = 3.3V 5x Mode, BAT = 3.3V 10x Mode, BAT = 3.3V Suspend Mode | | 135 672 1251 0.32 | | mA mA mA mA |
| V_{CLPROG} | CLPROG Servo Voltage in Current Limit | 1x, 5x, 10x Modes Suspend Mode | | 1.188 100 | | V mV |
| $V_{\text{UVLO_VBUS}}$ | V_{BUS} Undervoltage Lockout | Rising Threshold Falling Threshold | 3.95 | 4.30 4.00 | 4.35 | V V |
| $V_{\text{UVLO_VBUS}} - V_{\text{BAT}}$ | V_{BUS} to BAT Differential Undervoltage Lockout | Rising Threshold Falling Threshold | | 200 50 | | mV mV |
| V_{OUT} | V_{OUT} Voltage | 1x, 5x, 10x Modes, $0\text{V} < \text{BAT} < 4.2\text{V}$, $I_{\text{OUT}} = 0\text{mA}$, Battery Charger Off USB Suspend Mode, $I_{\text{OUT}} = 250\mu\text{A}$ | 3.4 4.5 | BAT + 0.3 4.6 | 4.7 4.7 | V V |
| f_{OSC} | Switching Frequency | | ● 1.8 | 2.25 | 2.7 | MHz |
| $R_{\text{PMOS_PowerPath}}$ | PMOS On-Resistance | | | 0.18 | | Ω |
| $R_{\text{NMOS_PowerPath}}$ | NMOS On-Resistance | | | 0.30 | | Ω |
| $I_{\text{PEAK_PowerPath}}$ | Peak Switch Current Limit | 1x, 5x Modes 10x Mode | | 2 3 | | A A |
| Battery Charger | | | | | | |
| V_{FLOAT} | BAT Regulated Output Voltage | | ● 4.179 4.165 | 4.200 4.200 | 4.221 4.235 | V V |
| I_{CHG} | Constant Current Mode Charge Current | $R_{\text{PROG}} = 5\text{k}$ | 980 185 | 1022 204 | 1065 223 | mA mA |
| I_{BAT} | Battery Drain Current | $V_{\text{BUS}} > V_{\text{UVLO}}$, Battery Charger Off, $I_{\text{OUT}} = 0\mu\text{A}$ $V_{\text{BUS}} = 0\text{V}$, $I_{\text{OUT}} = 0\mu\text{A}$ (Ideal Diode Mode) LTC3566 LTC3566-2 | 2 | 3.5 27 32 | 5 38 44 | μA μA μA |
| V_{PROG} | PROG Pin Servo Voltage | | | 1.000 | | V |
| $V_{\text{PROG_TRIKL}}$ | PROG Pin Servo Voltage in Trickle Charge | $V_{\text{BAT}} < V_{\text{TRIKL}}$ | | 0.100 | | V |
| $V_{\text{C/10}}$ | C/10 Threshold Voltage at PROG | | | 100 | | mV |
| h_{PROG} | Ratio of I_{BAT} to PROG Pin Current | | | 1022 | | mA/mA |
| I_{TRKL} | Trickle Charge Current | $\text{BAT} < V_{\text{TRKL}}$ | | 100 | | mA |
| V_{TRIKL} | Trickle Charge Threshold Voltage | BAT Rising | 2.7 | 2.85 | 3.0 | V |
| ΔV_{TRKL} | Trickle Charge Hysteresis Voltage | | | 135 | | mV |
| V_{RECHRG} | Recharge Battery Threshold Voltage | Threshold Voltage Relative to V_{FLOAT} | -75 | -100 | -125 | mV |
| t_{TERM} | Safety Timer Termination | Timer Starts When $\text{BAT} = V_{\text{FLOAT}}$ | 3.3 | 4 | 5 | Hour |
| t_{BADBAT} | Bad Battery Termination Time | $\text{BAT} < V_{\text{TRKL}}$ | 0.42 | 0.5 | 0.63 | Hour |
| $h_{\text{C/10}}$ | End of Charge Indication Current Ratio | (Note 5) | 0.088 | 0.1 | 0.112 | mA/mA |
| V_{CHRG} | $\overline{\text{CHRG}}$ Pin Output Low Voltage | $I_{\text{CHRG}} = 5\text{mA}$ | | 65 | 100 | mV |
| I_{CHRG} | $\overline{\text{CHRG}}$ Pin Leakage Current | $V_{\text{CHRG}} = 5\text{V}$ | | | 1 | μA |

ELECTRICAL CHARACTERISTICS

The ● denotes the specifications which apply over the full operating temperature range, otherwise specifications are at $T_A = 25^\circ\text{C}$. $V_{\text{BUS}} = 5\text{V}$, $V_{\text{BAT}} = 3.8\text{V}$, $DV_{\text{CC}} = 3.3\text{V}$, $R_{\text{CLPROG}} = 3.01\text{k}$, $R_{\text{PROG}} = 1\text{k}$, $V_{\text{IN1}} = V_{\text{OUT1}} = 3.8\text{V}$ unless otherwise noted.

| SYMBOL | PARAMETER | CONDITIONS | MIN | TYP | MAX | UNITS |
|--|---|---|------|----------------|----------------|---|
| $R_{\text{ON_CHG}}$ | Battery Charger Power FET On Resistance (Between V_{OUT} and BAT) | | | 0.18 | | Ω |
| T_{LIM} | Junction Temperature in Constant Temperature Mode | | | 110 | | $^\circ\text{C}$ |
| NTC | | | | | | |
| V_{COLD} | Cold Temperature Fault Threshold Voltage | Rising Threshold Hysteresis | 75.0 | 76.5 1.5 | 78.0 | $\%V_{\text{BUS}}$ $\%V_{\text{BUS}}$ |
| V_{HOT} | Hot Temperature Fault Threshold Voltage | Falling Threshold Hysteresis | 33.4 | 34.9 1.5 | 36.4 | $\%V_{\text{BUS}}$ $\%V_{\text{BUS}}$ |
| V_{DIS} | NTC Disable Threshold Voltage | Falling Threshold Hysteresis | 0.7 | 1.7 50 | 2.7 | $\%V_{\text{BUS}}$ mV |
| I_{NTC} | NTC Leakage Current | $V_{\text{NTC}} = V_{\text{BUS}} = 5\text{V}$ | -50 | | 50 | nA |
| Ideal Diode | | | | | | |
| V_{FWD} | Forward Voltage | $V_{\text{BUS}} = 0\text{V}$, $I_{\text{OUT}} = 10\text{mA}$ $I_{\text{OUT}} = 10\text{mA}$ | | 2 15 | | mV mV |
| R_{DROPOUT} | Internal Diode On-Resistance, Dropout | $V_{\text{BUS}} = 0\text{V}$ | | 0.18 | | Ω |
| $I_{\text{MAX_DIODE}}$ | Internal Diode Current Limit | | 1.6 | | | A |
| Always On 3.3V Supply | | | | | | |
| V_{LD03V3} | Regulated Output Voltage | $0\text{mA} < I_{\text{LD03V3}} < 25\text{mA}$ | 3.1 | 3.3 | 3.5 | V |
| $R_{\text{CL_LD03V3}}$ | Closed-Loop Output Resistance | | | 4 | | Ω |
| $R_{\text{OL_LD03V}}$ | Dropout Output Resistance | | | 23 | | Ω |
| Logic (I_{LIM0}, I_{LIM1}, EN1, CHRGEN, MODE) | | | | | | |
| V_{IL} | Logic Low Input Voltage | | | | 0.4 | V |
| V_{IH} | Logic High Input Voltage | | 1.2 | | | V |
| I_{PD1} | I_{LIM0} , I_{LIM1} , EN1, MODE Pull-Down Currents | | | 1.6 | | μA |
| $I_{\text{PD1_CHRGEN}}$ | CHRGEN Pull-Down Current | | | 1.6 | 10 | μA |
| Buck-Boost Regulator | | | | | | |
| V_{IN1} | Input Supply Voltage | | 2.7 | | 5.5 | V |
| V_{OUTUVLO} | V_{OUT} UVLO - V_{OUT} Falling V_{OUT} UVLO - V_{OUT} Rising | V_{IN1} Connected to V_{OUT} Through Low Impedance. Switching Regulator Disabled in UVLO | 2.5 | 2.6 2.8 | 2.9 | V V |
| f_{OSC} | Oscillator Frequency | PWM Mode ● | 1.8 | 2.25 | 2.7 | MHz |
| I_{VIN1} | Input Current | PWM Mode, $I_{\text{OUT1}} = 0\mu\text{A}$ Burst Mode® Operation, $I_{\text{OUT1}} = 0\mu\text{A}$ Shutdown | | 220 13 0 | 400 20 1 | μA μA μA |

Burst Mode is a registered trademark of Linear Technology Corporation.

ELECTRICAL CHARACTERISTICS The ● denotes the specifications which apply over the full operating temperature range, otherwise specifications are at $T_A = 25^\circ\text{C}$. $V_{\text{BUS}} = 5\text{V}$, $V_{\text{BAT}} = 3.8\text{V}$, $DV_{\text{CC}} = 3.3\text{V}$, $R_{\text{CLPROG}} = 3.01\text{k}$, $R_{\text{PROG}} = 1\text{k}$, $V_{\text{IN1}} = V_{\text{OUT1}} = 3.8\text{V}$ unless otherwise noted.

| SYMBOL | PARAMETER | CONDITIONS | MIN | TYP | MAX | UNITS | |
|---------------------------|--|---|------|-------|-------|-------|---------------|
| $V_{\text{OUT1(LOW)}}$ | Minimum Regulated Output Voltage | For Burst Mode Operation or Synchronous PWM Operation | | 2.65 | 2.75 | V | |
| $V_{\text{OUT1(HIGH)}}$ | Maximum Regulated Output Voltage | | 5.50 | 5.60 | | V | |
| I_{LIMF1} | Forward Current Limit (Switch A) | PWM Mode | ● | 2 | 2.5 | 3 | A |
| $I_{\text{PEAK1(BURST)}}$ | Forward Burst Current Limit (Switch A) | Burst Mode Operation | ● | 200 | 275 | 350 | mA |
| $I_{\text{ZERO1(BURST)}}$ | Reverse Burst Current Limit (Switch D) | Burst Mode Operation | ● | -30 | 0 | 30 | mA |
| $I_{\text{MAX1(BURST)}}$ | Maximum Deliverable Output Current in Burst Mode Operation | $2.7\text{V} \leq V_{\text{IN1}} \leq 5.5\text{V}$, $2.75\text{V} \leq V_{\text{OUT}} \leq 5.5\text{V}$ (Note 6) | | 50 | | | mA |
| V_{FB1} | Feedback Servo Voltage | | ● | 0.780 | 0.800 | 0.820 | V |
| I_{FB1} | FB1 Input Current | $V_{\text{FB1}} = 0.8\text{V}$ | | -50 | | 50 | nA |
| $R_{\text{DS(ON)P}}$ | PMOS $R_{\text{DS(ON)}}$ | Switches A, D | | 0.22 | | | Ω |
| $R_{\text{DS(ON)N}}$ | NMOS $R_{\text{DS(ON)}}$ | Switches B, C | | 0.17 | | | Ω |
| $I_{\text{LEAK(P)}}$ | PMOS Switch Leakage | Switches A, D | | -1 | | 1 | μA |
| $I_{\text{LEAK(N)}}$ | NMOS Switch Leakage | Switches B, C | | -1 | | 1 | μA |
| R_{VOUT1} | V_{OUT1} Pull-Down in Shutdown | | | 10 | | | k Ω |
| $D_{\text{BUCK(MAX)}}$ | Maximum Buck Duty Cycle | PWM Mode | ● | 100 | | | % |
| $D_{\text{BOOST(MAX)}}$ | Maximum Boost Duty Cycle | PWM Mode | | 75 | | | % |
| t_{SS1} | Soft-Start Time | | | 0.5 | | | ms |

Note 1: Stresses beyond those listed under Absolute Maximum Ratings may cause permanent damage to the device. Exposure to any Absolute Maximum Rating condition for extended periods may affect device reliability and lifetime.

Note 2: The LTC3566 family is guaranteed to meet performance specifications from 0°C to 85°C . Specifications over the -40°C to 85°C operating temperature range are assured by design, characterization and correlation with statistical process controls.

Note 3: The LTC3566 family includes overtemperature protection that is intended to protect the device during momentary overload conditions.

Junction temperatures will exceed 125°C when overtemperature protection is active. Continuous operation above the specified maximum operating junction temperature may impair device reliability.

Note 4: Total input current is the sum of quiescent current, I_{VBUSQ} , and measured current given by:

$$V_{\text{CLPROG}}/R_{\text{CLPROG}} * (h_{\text{CLPROG}} + 1)$$

Note 5: $h_{\text{C}/10}$ is expressed as a fraction of measured full charge current with indicated PROG resistor.

Note 6: Guaranteed by design.

TYPICAL PERFORMANCE CHARACTERISTICS $T_A = 25^\circ\text{C}$ unless otherwise noted.

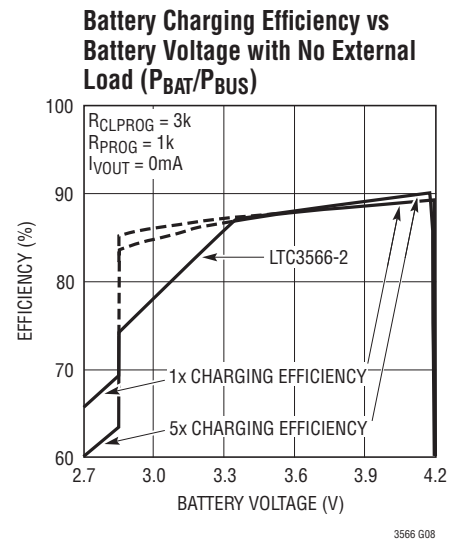
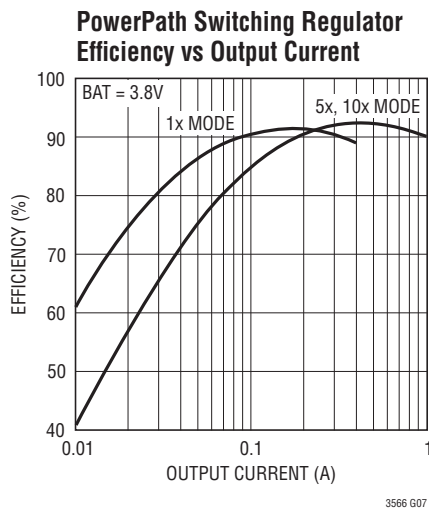
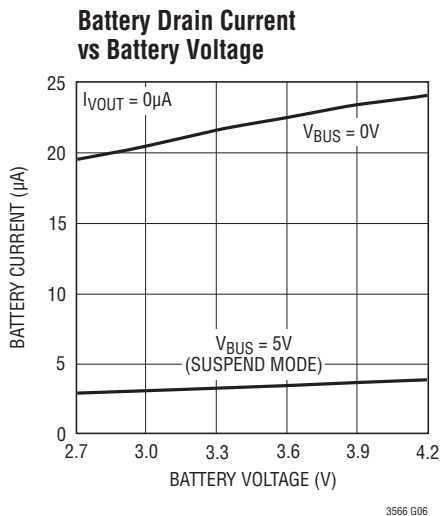
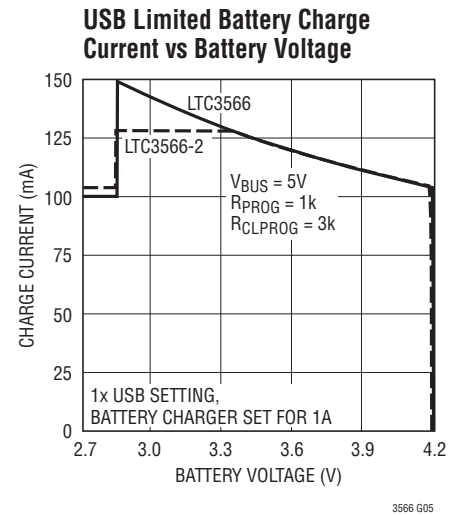
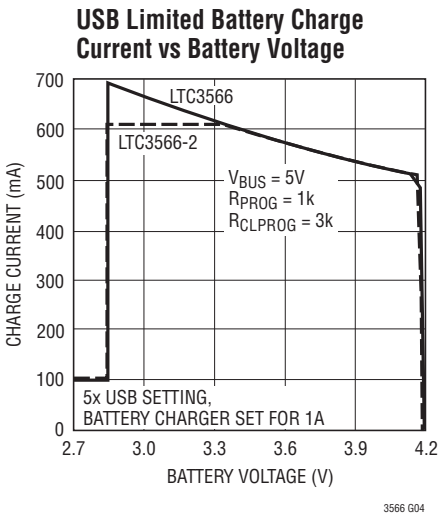
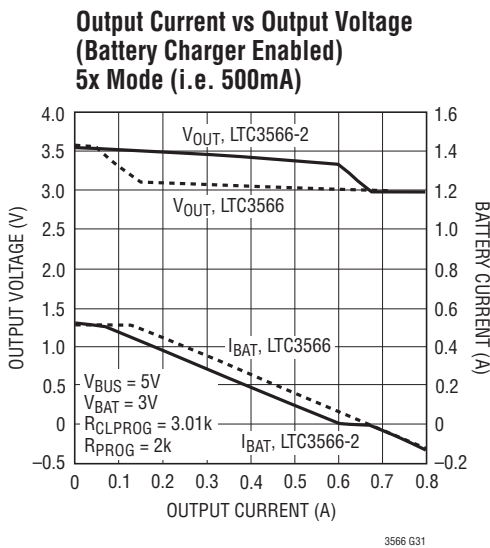
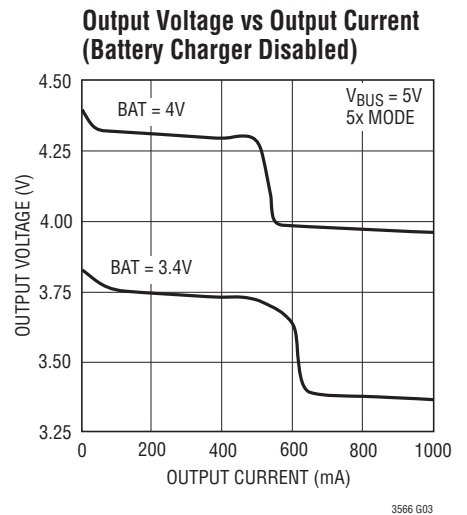
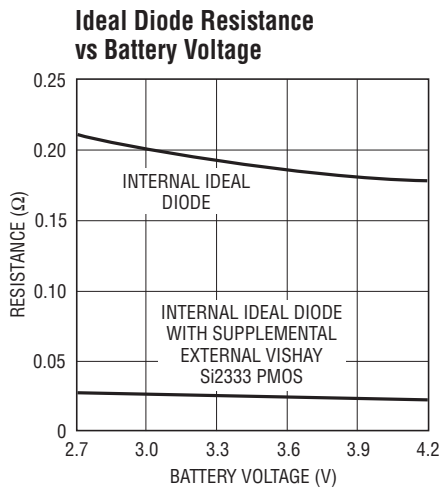
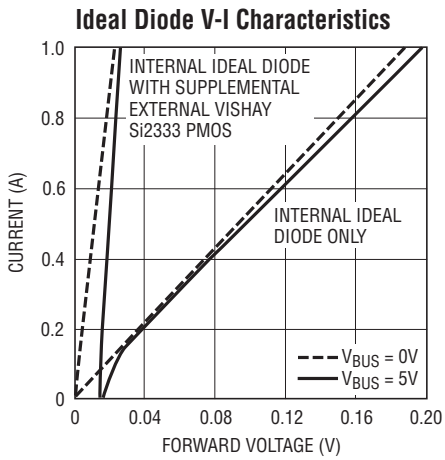

TYPICAL PERFORMANCE CHARACTERISTICS $T_A = 25^\circ\text{C}$ unless otherwise noted.

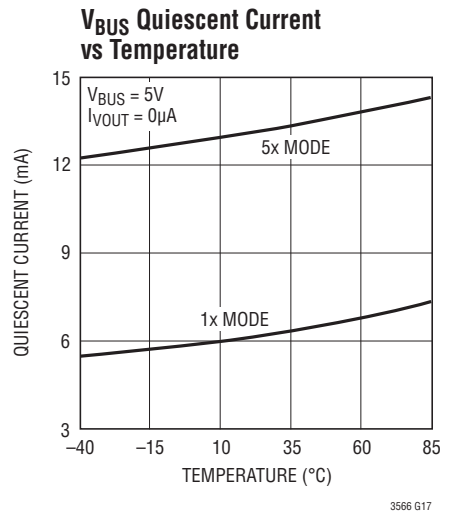
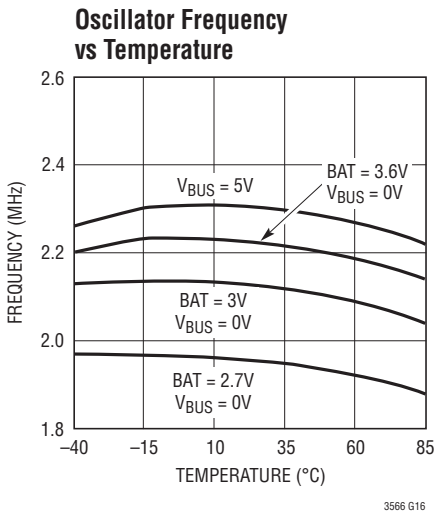
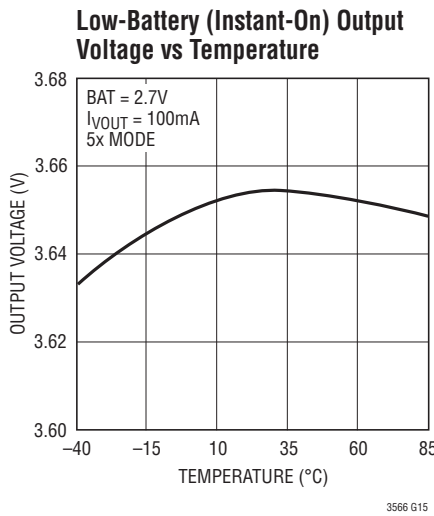
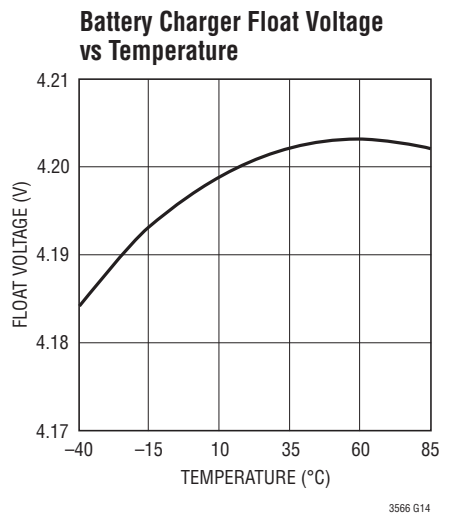
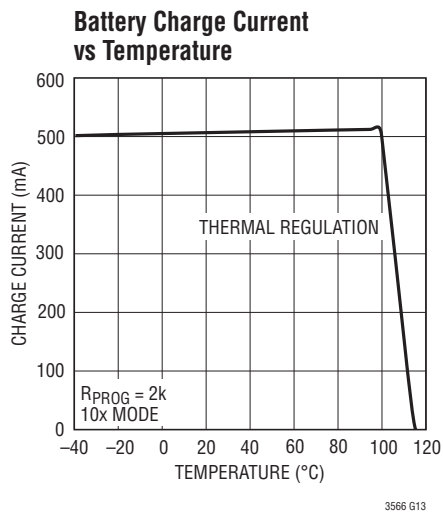
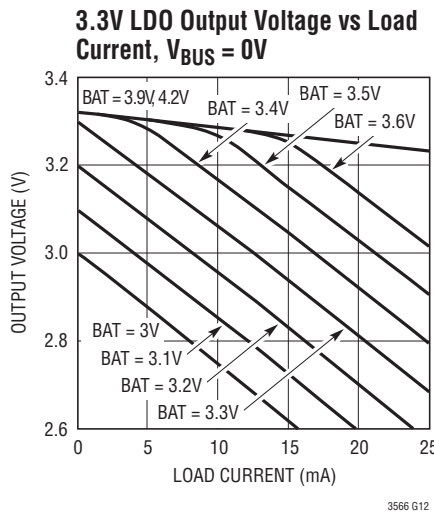
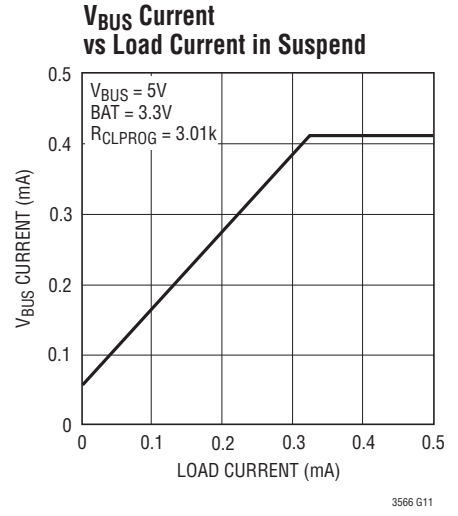
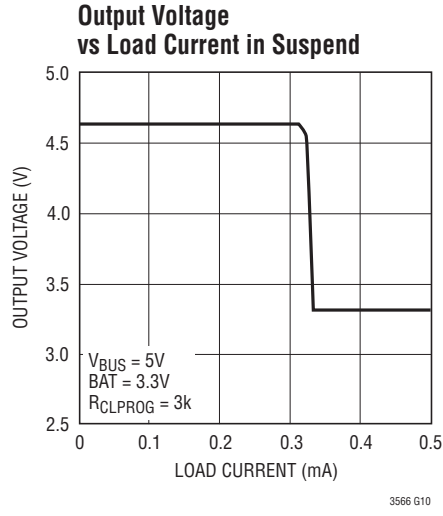
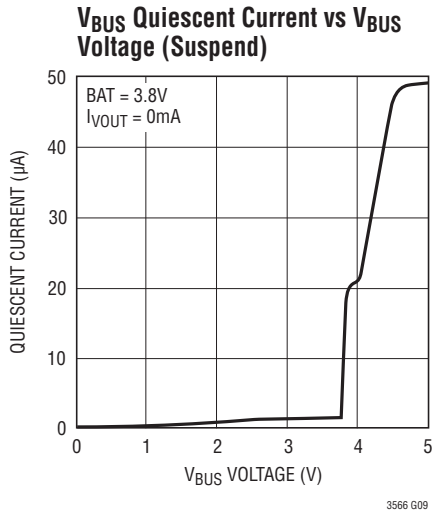

TYPICAL PERFORMANCE CHARACTERISTICS $T_A = 25^\circ\text{C}$ unless otherwise noted.

V_{BUS} Quiescent Current in Suspend vs Temperature

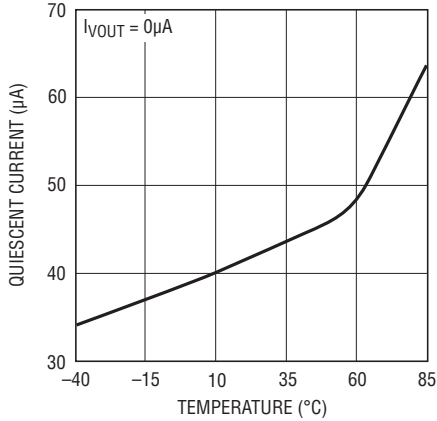

CHRG Pin Current vs Voltage (Pull-Down State)

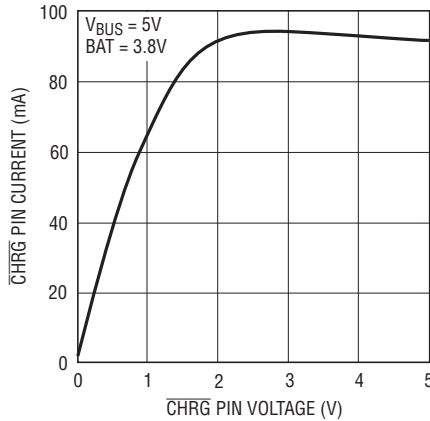

Battery Drain Current vs Temperature

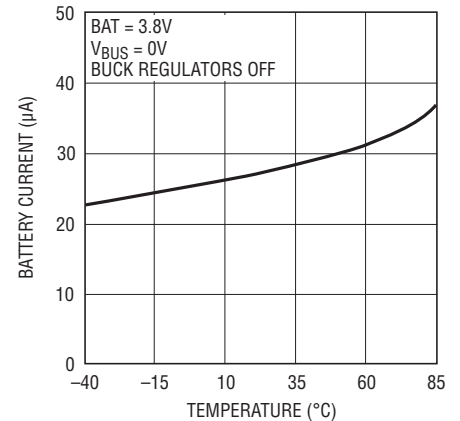

$R_{\text{DS(ON)}}$ for Buck-Boost Regulator Power Switches vs Temperature

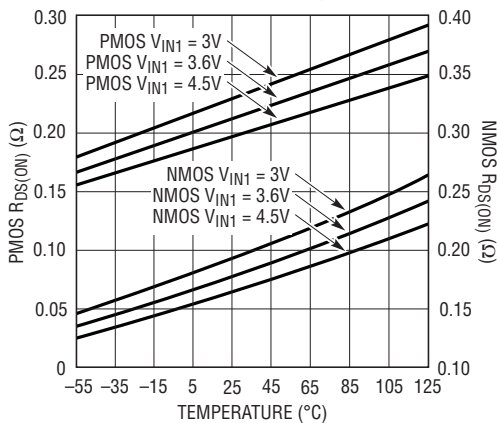

Buck-Boost Regulator Current Limit vs Temperature

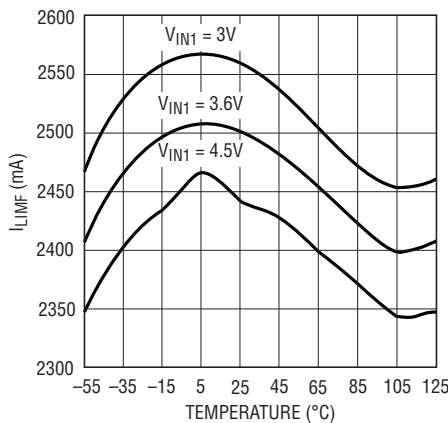

Buck-Boost Regulator Burst Mode Operation Quiescent Current

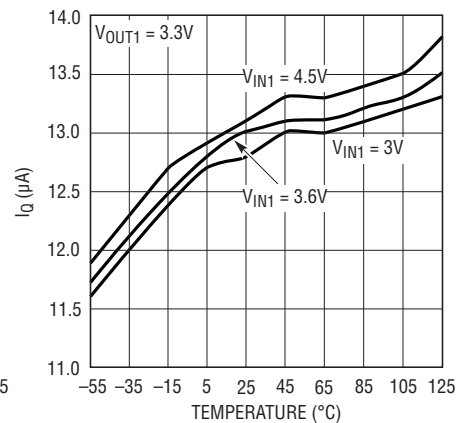

Buck-Boost Regulator PWM Mode Efficiency

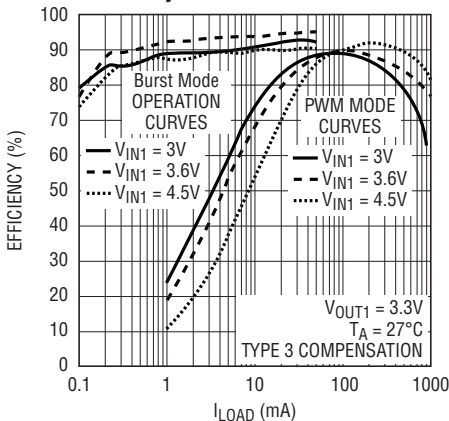

Buck-Boost Regulator PWM Efficiency vs V_{IN1}

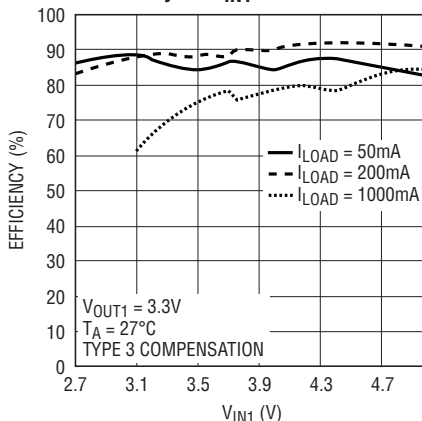

Buck-Boost Regulator vs I_{LOAD}

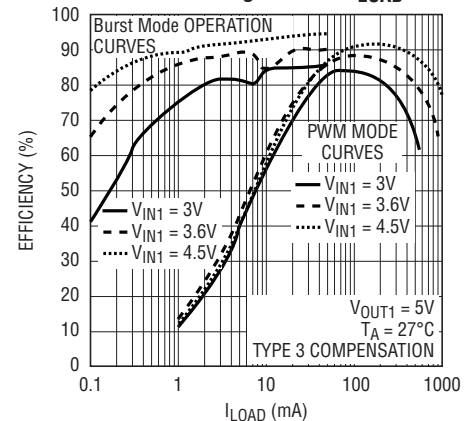

TYPICAL PERFORMANCE CHARACTERISTICS $T_A = 25^\circ\text{C}$ unless otherwise noted.

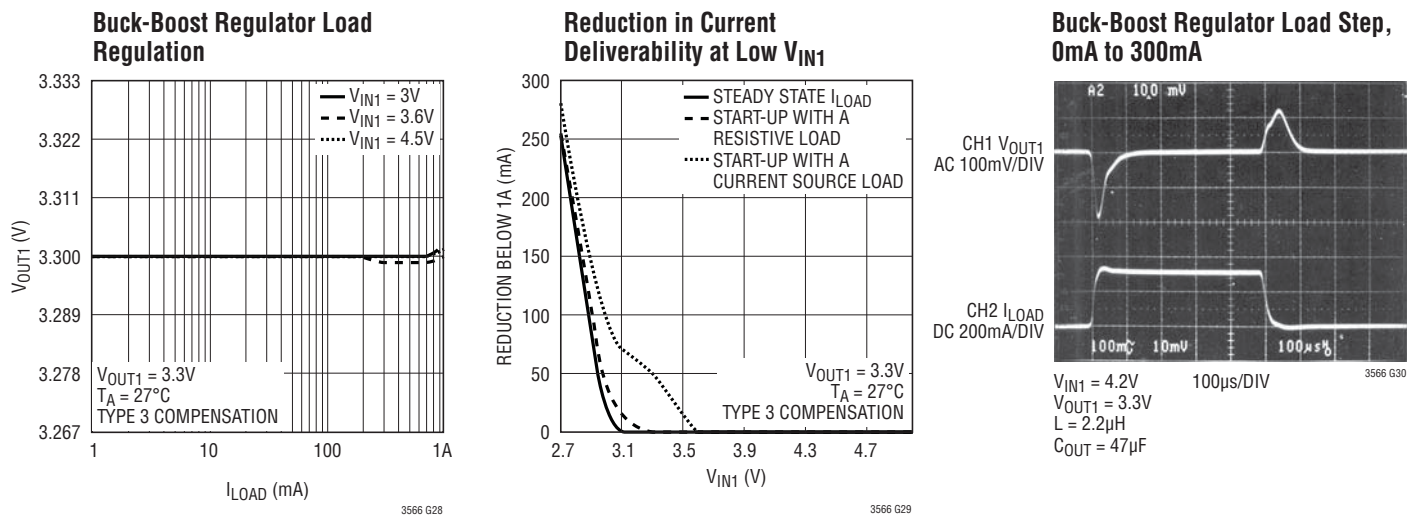

PIN FUNCTIONS

LD03V3 (Pin 1): 3.3V LDO Output Pin. This pin provides a regulated, always-on, 3.3V supply voltage. LD03V3 gets its power from V_{OUT} . It may be used for light loads such as a watchdog microprocessor or real time clock. A $1\mu\text{F}$ capacitor is required from LD03V3 to ground. If the LD03V3 output is not used it should be disabled by connecting it to V_{OUT} .

CLPROG (Pin 2): USB Current Limit Program and Monitor Pin. A resistor from CLPROG to ground determines the upper limit of the current drawn from the V_{BUS} pin. A fraction of the V_{BUS} current is sent to the CLPROG pin when the synchronous switch of the PowerPath switching regulator is on. The switching regulator delivers power until the CLPROG pin reaches 1.188V. Several V_{BUS} current limit settings are available via user input which will typically correspond to the 500mA and the 100mA USB specifications. A multilayer ceramic averaging capacitor or R-C network is required at CLPROG for filtering.

NTC (Pin 3): Input to the Thermistor Monitoring Circuits. The NTC pin connects to a battery's thermistor to determine if the battery is too hot or too cold to charge. If the battery's temperature is out of range, charging is paused until it re-enters the valid range. A low drift bias resistor is required from V_{BUS} to NTC and a thermistor is required from NTC to ground. If the NTC function is not desired, the NTC pin should be grounded.

FB1 (Pin 4): Feedback Input for the (Buck-Boost) Switching Regulator. When the regulator's control loop is complete, this pin serves to a fixed voltage of 0.8V.

V_{C1} (Pin 5): Output of the Error Amplifier and Voltage Compensation Node for the (Buck-Boost) Switching Regulator. External Type I or Type III compensation (to FB1) connects to this pin. See Applications Information section for selecting buck-boost loop compensation components.

GND (Pins 6, 12): Power GND pins for the buck-boost.

SWAB1 (Pin 7): Switch Node for the (Buck-Boost) Switching Regulator. Connected to internal power switches A and B. External inductor connects between this node and SWCD1.

MODE (Pin 8): Logic Input. Mode enables Burst Mode functionality for the buck-boost switching regulator when pin is set high. Has a $1.6\mu\text{A}$ internal pull-down current source.

V_{IN1} (Pin 9): Power Input for the (Buck-Boost) Switching Regulator. This pin will generally be connected to V_{OUT} (Pin 20). A $1\mu\text{F}$ (min) MLCC capacitor is recommended on this pin.

V_{OUT1} (Pin 10): Regulated Output Voltage for the (Buck-Boost) Switching Regulator.

PIN FUNCTIONS

SWCD1 (Pin 11): Switch Node for the (Buck-Boost) Switching Regulator. Connected to internal power switches C and D. External inductor connects between this node and SWAB1.

ILIM0 (Pin 13): Logic Input. Control pin for ILIM0 bit of the current limit of the PowerPath switching regulator. See Table 2. Active high. Has a 1.6 μ A internal pull-down current source.

ILIM1 (Pin 14): Logic Input. Control pin for ILIM1 bit of the current limit of the PowerPath switching regulator. See Table 2. Active high. Has a 1.6 μ A internal pull-down current source.

PROG (Pin 15): Charge Current Program and Charge Current Monitor Pin. Connecting a resistor from PROG to ground programs the charge current. If sufficient input power is available in constant-current mode, this pin serves to 1V. The voltage on this pin always represents the actual charge current.

CHRG (Pin 16): Open-Drain Charge Status Output. The $\overline{\text{CHRG}}$ pin indicates the status of the battery charger. Four possible states are represented by $\overline{\text{CHRG}}$: charging, not charging, unresponsive battery and battery temperature out of range. $\overline{\text{CHRG}}$ is modulated at 35kHz and switches between a low and high duty cycle for easy recognition by either humans or microprocessors. See Table 1. $\overline{\text{CHRG}}$ requires a pull-up resistor and/or LED to provide indication.

GND (Pin 17): GND pin for USB Power Manager.

GATE (Pin 18): Analog Output. This pin controls the gate of an optional external P-channel MOSFET transistor used to supplement the ideal diode between V_{OUT} and BAT. The external ideal diode operates in parallel with the internal ideal diode. The source of the P-channel MOSFET should be connected to V_{OUT} and the drain should be connected to BAT. If the external ideal diode FET is not used, GATE should be left floating.

BAT (Pin 19): Single-Cell Li-Ion Battery Pin. Depending on available V_{BUS} power, a Li-Ion battery on BAT will either deliver power to V_{OUT} through the ideal diode or be charged from V_{OUT} via the battery charger.

V_{OUT} (Pin 20): Output Voltage of the Switching PowerPath Controller and Input Voltage of the Battery Charger. The majority of the portable product should be powered from V_{OUT} . The LTC3566 family will partition the available power between the external load on V_{OUT} and the internal battery charger. Priority is given to the external load and any extra power is used to charge the battery. An ideal diode from BAT to V_{OUT} ensures that V_{OUT} is powered even if the load exceeds the allotted power from V_{BUS} or if the V_{BUS} power source is removed. V_{OUT} should be bypassed with a low impedance ceramic capacitor.

V_{BUS} (Pin 21): Primary Input Power Pin. This pin delivers power to V_{OUT} via the SW pin by drawing controlled current from a DC source such as a USB port or wall adapter.

SW (Pin 22): Power Transmission Pin for the USB PowerPath. The SW pin delivers power from V_{BUS} to V_{OUT} via the step-down switching regulator. A 3.3 μ H inductor should be connected from SW to V_{OUT} .

$\overline{\text{CHRGEN}}$ (Pin 23): Logic Input. This logic input pin independently enables the battery charger. Active low. Has a 1.6 μ A internal pull-down current source.

EN1 (Pin 24): Logic Input. This logic input pin independently enables the buck-boost switching regulator. Active high. Has a 1.6 μ A internal pull-down current source.

Exposed Pad (Pin 25): Ground. Buck-boost logic and USB Power Manager ground connections. The Exposed Pad should be connected to a continuous ground plane on the printed circuit board directly under the LTC3566.

BLOCK DIAGRAM

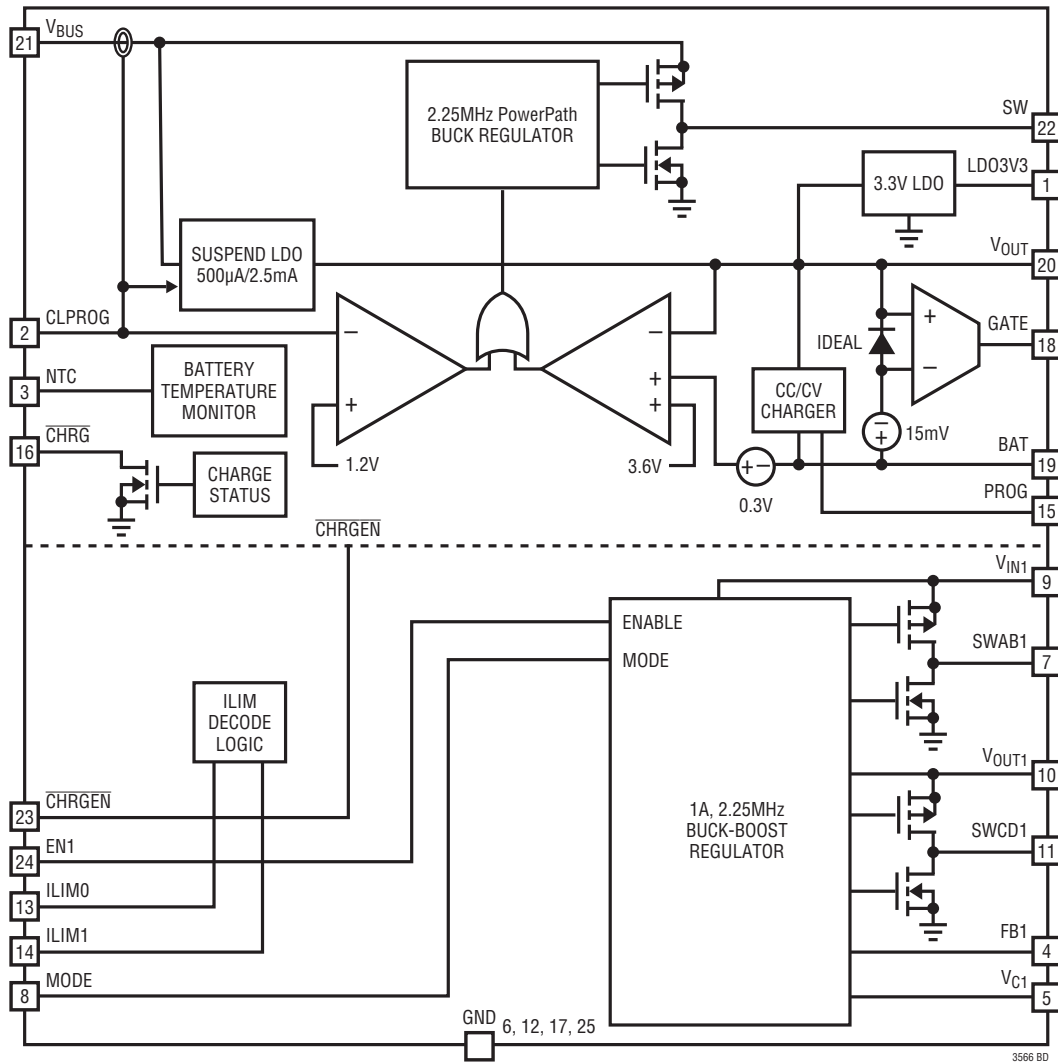

3566 BD

OPERATION

Introduction

The LTC3566 family are highly integrated power management ICs which includes a high efficiency switch mode PowerPath controller, a battery charger, an ideal diode, an always-on LDO, and a 1A buck-boost switching regulator. The entire chip is controlled via direct digital inputs.

Designed specifically for USB applications, the PowerPath controller incorporates a precision average input current step-down switching regulator to make maximum use of the allowable USB power. Because power is conserved, the LTC3566 family allows the load current on V_{OUT} to exceed the current drawn by the USB port, making maximum use of the allowable USB power for battery charging. For USB compatibility, the switching regulator includes a precision average input current limit. The PowerPath switching regulator and battery charger communicate to ensure that the average input current never exceeds the USB specifications.

The PowerPath switching regulator and battery charger communicate to ensure that the input current never violates the USB specifications.

The ideal diode from BAT to V_{OUT} guarantees that ample power is always available to V_{OUT} even if there is insufficient or absent power at V_{BUS} .

An always-on LDO provides a regulated 3.3V from available power at V_{OUT} . Drawing very little quiescent current, this LDO will be on at all times and can be used to supply up to 25mA.

The LTC3566 family also has a general purpose buck-boost switching regulator, which can be independently enabled via direct digital control. Along with constant frequency PWM mode, the buck-boost regulator has a low power burst-only mode setting for significantly reduced quiescent current under light load conditions.

High Efficiency Switching PowerPath Controller

Whenever V_{BUS} is available and the PowerPath switching regulator is enabled, power is delivered from V_{BUS} to V_{OUT} via SW. V_{OUT} drives both the external load (including the buck-boost regulator) and the battery charger.

If the combined load does not exceed the PowerPath switching regulator's programmed input current limit, V_{OUT} will track 0.3V above the battery (Bat-Track). By keeping the voltage across the battery charger low, efficiency is optimized because power lost to the linear battery charger is minimized. Power available to the external load is therefore optimized.

If the combined load at V_{OUT} is large enough to cause the switching power supply to reach the programmed input current limit, the battery charger will reduce its charge current by the amount necessary to enable the external load to be satisfied. Even if the battery charge current is programmed to exceed the allowable USB current, the USB specification for average input current will not be violated. The battery charger will reduce its current as needed. Furthermore, load current at V_{OUT} will always be prioritized and only remaining available power will be used to charge the battery.

If the voltage at BAT is below 3.3V, and the load requirement does not cause the switching regulator to exceed its input current limit set point, V_{OUT} will regulate at a fixed 3.6V as shown in Figure 1 thereby providing Instant-On operation. If the load exceeds the available power, V_{OUT} will drop to a voltage between 3.6V and the battery voltage. In the case where the battery is not present, and again, the load requirement does not cause the switching regulator to exceed the USB specification, V_{OUT} will regulate at a fixed 4.5V or 300mV above the 4.2V battery float voltage also providing Instant-On operation. In this case when the load exceeds the available USB power, V_{OUT} will drop toward ground.

The power delivered from V_{BUS} to V_{OUT} is controlled by a 2.25MHz constant-frequency step-down switching regulator. To meet the USB maximum load specification, the switching regulator includes a control loop which ensures that the average input current is below the level programmed at CLPROG.

The current at CLPROG is a fraction (h_{CLPROG}^{-1}) of the V_{BUS} current. When a programming resistor and an averaging capacitor are connected from CLPROG to GND, the voltage on CLPROG represents the average input current of the switching regulator. When the input current approaches

OPERATION

the programmed limit, CLPROG reaches V_{CLPROG} , 1.188V and power out is held constant.

The input current is programmed by the ILIM0 and ILIM1 pins. It can be configured to limit average input current to one of several possible settings as well as be deactivated (USB Suspend). The input current limit will be set by the V_{CLPROG} servo voltage and the resistor on CLPROG according to the following expression:

$$I_{VBUS} = I_{BUSQ} + \frac{V_{CLPROG}}{R_{CLPROG}} \cdot (h_{CLPROG} + 1)$$

Figure 1 shows the range of possible voltages at V_{OUT} as a function of battery voltage.

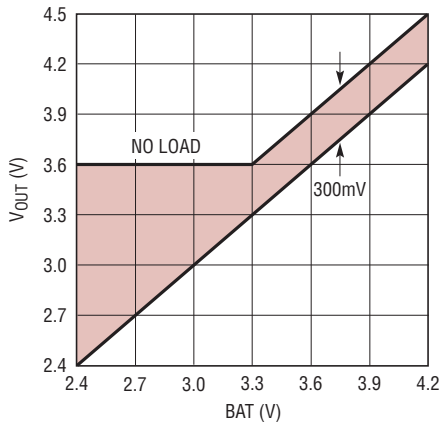

Figure 1. V_{OUT} vs BAT

The LTC3566 Versus the LTC3566-2

For very low battery voltages, the battery charger acts like a load and, due to limited input power, its current can cause V_{OUT} to approach the battery voltage when operating under input current limit conditions. To prevent V_{OUT} from falling to this level, the LTC3566-2 includes an undervoltage circuit that automatically detects that V_{OUT} is falling and reduces the battery charge current as V_{OUT} falls from 3.5V to 3.3V. This reduction prevents V_{OUT} from collapsing suddenly towards the battery voltage when input current limit is reached and ensures that load current and output voltage are always prioritized while delivering as much battery charge current as possible. The standard LTC3566 does not include this circuit and thus favors maximum charge current at all times over output voltage preservation. See graph titled Output Current vs Output

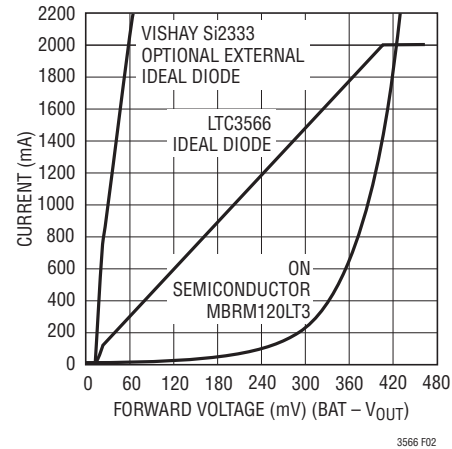

Figure 2. Ideal Diode Operation

Voltage (Battery Charger Enabled) 5x Mode in the Typical Performance Characteristics section.

If instant-on operation under low battery and input current limited conditions is a requirement, then the LTC3566-2 should be used. If maximum charge efficiency at low battery voltages is preferred, and instant-on operation is not a requirement, then the standard LTC3566 should be selected. All versions of the LTC3566 family will start up with a removed battery.

Ideal Diode from BAT to V_{OUT}

The LTC3566 family has an internal ideal diode as well as a controller for an optional external ideal diode. The ideal diode controller is always on and will respond quickly whenever V_{OUT} drops below BAT.

If the load current increases beyond the power allowed from the switching regulator, additional power will be pulled from the battery via the ideal diode. Furthermore, if power to V_{BUS} (USB or wall power) is removed, then all of the application power will be provided by the battery via the ideal diode. The transition from input power to battery power at V_{OUT} will be quick enough to allow only a 10 μ F capacitor to keep V_{OUT} from drooping. The ideal diode consists of a precision amplifier that enables a large on-chip P-channel MOSFET transistor whenever the voltage at V_{OUT} is approximately 15mV (V_{FWD}) below the voltage at BAT. The resistance of the internal ideal diode is approximately 180m Ω . If this is sufficient for the application, then no external components are necessary. However, if more

OPERATION

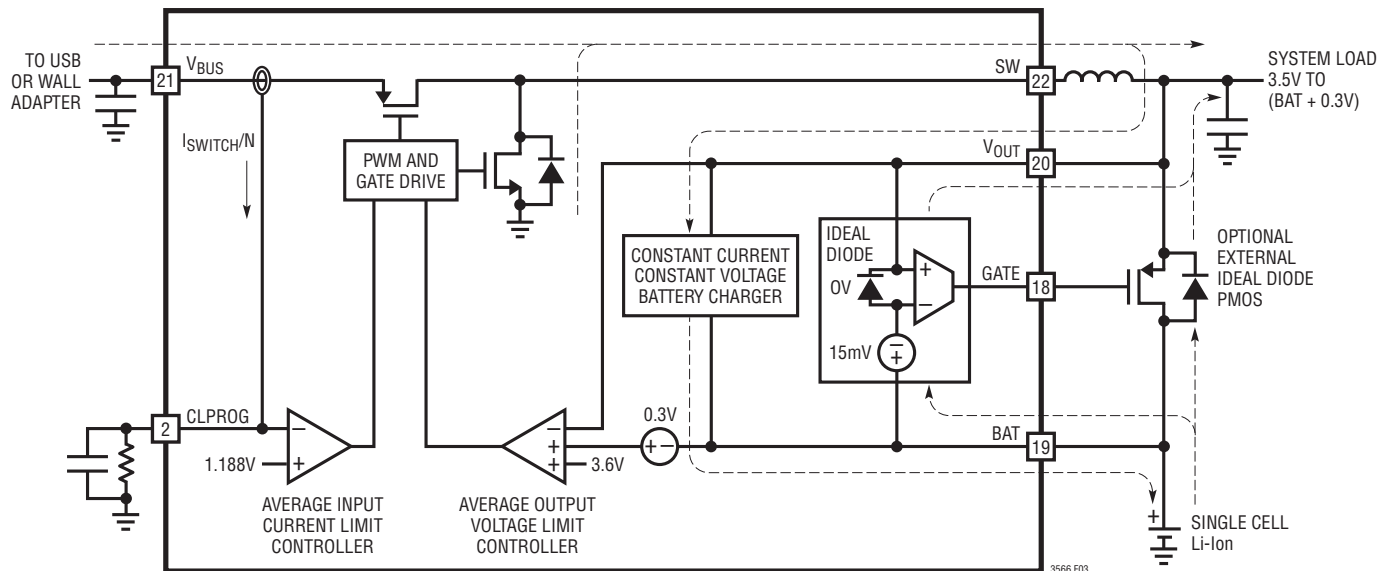

Figure 3. PowerPath Block Diagram

conductance is needed, an external P-channel MOSFET transistor can be added from BAT to V_{OUT} .

When an external P-channel MOSFET transistor is present, the GATE pin of the LTC3566 family drives its gate for automatic ideal diode control. The source of the external P-channel MOSFET should be connected to V_{OUT} and the drain should be connected to BAT. Capable of driving a 1nF load, the GATE pin can control an external P-channel MOSFET transistor having an on-resistance of 40m Ω or lower.

Suspend LDO

If the LTC3566 family is configured for USB suspend mode, the switching regulator is disabled and the suspend LDO provides power to the V_{OUT} pin (presuming there is power available to V_{BUS}). This LDO will prevent the battery from running down when the portable product has access to a suspended USB port. Regulating at 4.6V, this LDO only becomes active when the switching converter is disabled (suspended). In accordance with the USB specification, the input to the LDO is current limited so that it will not exceed the 500 μ A low power suspend specification. If the load

on V_{OUT} exceeds the suspend current limit, the additional current will come from the battery via the ideal diode.

3.3V Always-On Supply

The LTC3566 family includes a low quiescent current low dropout regulator that is always powered. This LDO can be used to provide power to a system pushbutton controller, standby microcontroller or real time clock. Designed to deliver up to 25mA, the always-on LDO requires at least a 1 μ F low impedance ceramic bypass capacitor for compensation. The LDO is powered from V_{OUT} , and therefore will enter dropout at loads less than 25mA as V_{OUT} falls near 3.3V. If the LDO3V3 output is not used, it should be disabled by connecting it to V_{OUT} .

V_{BUS} Undervoltage Lockout (UVLO)

An internal undervoltage lockout circuit monitors V_{BUS} and keeps the PowerPath switching regulator off until V_{BUS} rises above 4.30V and is about 200mV above the battery voltage. Hysteresis on the UVLO turns off the regulator if V_{BUS} drops below 4.00V or to within 50mV of BAT. When this happens, system power at V_{OUT} will be drawn from the battery via the ideal diode.

OPERATION

Battery Charger

The LTC3566 family includes a constant-current/constant-voltage battery charger with automatic recharge, automatic termination by safety timer, low voltage trickle charging, bad cell detection and thermistor sensor input for out-of-temperature charge pausing.

Battery Preconditioning

When a battery charge cycle begins, the battery charger first determines if the battery is deeply discharged. If the battery voltage is below V_{TRKL} , typically 2.85V, an automatic trickle charge feature sets the battery charge current to 10% of the programmed value. If the low voltage persists for more than 1/2 hour, the battery charger automatically terminates and indicates via the \overline{CHRG} pin that the battery was unresponsive.

Once the battery voltage is above 2.85V, the battery charger begins charging in full power constant-current mode. The current delivered to the battery will try to reach $1022V/R_{PROG}$. Depending on available input power and external load conditions, the battery charger may or may not be able to charge at the full programmed rate. The external load will always be prioritized over the battery charge current. The USB current limit programming will always be observed and only additional power will be available to charge the battery. When system loads are light, battery charge current will be maximized.

Charge Termination

The battery charger has a built-in safety timer. When the voltage on the battery reaches the pre-programmed float voltage of 4.200V, the battery charger will regulate the battery voltage and the charge current will decrease naturally. Once the battery charger detects that the battery has reached 4.200V, the four hour safety timer is started. After the safety timer expires, charging of the battery will discontinue and no more current will be delivered.

Automatic Recharge

After the battery charger terminates, it will remain off drawing only microamperes of current from the battery. If the portable product remains in this state long enough,

the battery will eventually self discharge. To ensure that the battery is always topped off, a charge cycle will automatically begin when the battery voltage falls below 4.1V. In the event that the safety timer is running when the battery voltage falls below 4.1V, it will reset back to zero. To prevent brief excursions below 4.1V from resetting the safety timer, the battery voltage must be below 4.1V for more than 1.3ms. The charge cycle and safety timer will also restart if the V_{BUS} UVLO cycles low and then high (e.g. V_{BUS} is removed and then replaced) or if the battery charger is cycled on and off by the \overline{CHRGEN} digital I/O pin.

Charge Current

The charge current is programmed using a single resistor from PROG to ground. $1/1022^{th}$ of the battery charge current is sent to PROG which will attempt to servo to 1.000V. Thus, the battery charge current will try to reach 1022 times the current in the PROG pin. The program resistor and the charge current are calculated using the following equations:

$$R_{PROG} = \frac{1022V}{I_{CHG}}, I_{CHG} = \frac{1022V}{R_{PROG}}$$

In either the constant-current or constant-voltage charging modes, the voltage at the PROG pin will be proportional to the actual charge current delivered to the battery. Therefore, the actual charge current can be determined at any time by monitoring the PROG pin voltage and using the following equation:

$$I_{BAT} = \frac{V_{PROG}}{R_{PROG}} \cdot 1022$$

In many cases, the actual battery charge current, I_{BAT} , will be lower than I_{CHG} due to limited input power available and prioritization with the system load drawn from V_{OUT} .

Charge Status Indication

The \overline{CHRG} pin indicates the status of the battery charger. Four possible states are represented by \overline{CHRG} which include charging, not charging, unresponsive battery and battery temperature out of range.

OPERATION

The signal at the $\overline{\text{CHRG}}$ pin can be easily recognized as one of the above four states by either a human or a microprocessor. An open drain output, the $\overline{\text{CHRG}}$ pin can drive an indicator LED through a current limiting resistor for human interfacing or simply a pull-up resistor for microprocessor interfacing.

To make the $\overline{\text{CHRG}}$ pin easily recognized by both humans and microprocessors, the pin is either low for charging, high for not charging, or it is switched at high frequency (35kHz) to indicate the two possible faults, unresponsive battery and battery temperature out of range.

When charging begins, $\overline{\text{CHRG}}$ is pulled low and remains low for the duration of a normal charge cycle. When charging is complete, i.e., the BAT pin reaches 4.200V and the charge current has dropped to one tenth of the programmed value, the $\overline{\text{CHRG}}$ pin is released (Hi-Z). If a fault occurs, the pin is switched at 35kHz. While switching, its duty cycle is modulated between a high and low value at a very low frequency. The low and high duty cycles are disparate enough to make an LED appear to be on or off thus giving the appearance of blinking. Each of the two faults has its own unique blink rate for human recognition as well as two unique duty cycles for machine recognition.

The $\overline{\text{CHRG}}$ pin does not respond to the C/10 threshold if the LTC3566 family is in V_{BUS} current limit. This prevents false end of charge indications due to insufficient power available to the battery charger.

Table 1 illustrates the four possible states of the $\overline{\text{CHRG}}$ pin when the battery charger is active.

Table 1. $\overline{\text{CHRG}}$ Output Pin

| STATUS | FREQUENCY | MODULATION (BLINK) FREQUENCY | DUTY CYCLE |
|--------------|-----------|------------------------------|---------------|
| Charging | 0Hz | 0Hz (Lo-Z) | 100% |
| Not Charging | 0Hz | 0Hz (Hi-Z) | 0% |
| NTC Fault | 35kHz | 1.5Hz at 50% | 6.25%, 93.75% |
| Bad Battery | 35kHz | 6.1Hz at 50% | 12.5%, 87.5% |

An NTC fault is represented by a 35kHz pulse train whose duty cycle alternates between 6.25% and 93.75% at a 1.5Hz rate. A human will easily recognize the 1.5Hz rate as a slow blinking which indicates the out-of-range battery

temperature while a microprocessor will be able to decode either the 6.25% or 93.75% duty cycles as an NTC fault.

If a battery is found to be unresponsive to charging (i.e., its voltage remains below 2.85V, for 1/2 hour), the $\overline{\text{CHRG}}$ pin gives the battery fault indication. For this fault, a human would easily recognize the frantic 6.1Hz fast blink of the LED while a microprocessor would be able to decode either the 12.5% or 87.5% duty cycles as a bad battery fault.

Note that the LTC3566 family is a 3-terminal PowerPath product where system load is always prioritized over battery charging. Due to excessive system load, there may not be sufficient power to charge the battery beyond the trickle charge threshold voltage within the bad battery timeout period. In this case, the battery charger will falsely indicate a bad battery. System software may then reduce the load and reset the battery charger to try again.

Although very improbable, it is possible that a duty cycle reading could be taken at the bright-dim transition (low duty cycle to high duty cycle). When this happens the duty cycle reading will be precisely 50%. If the duty cycle reading is 50%, system software should disqualify it and take a new duty cycle reading.

NTC Thermistor

The battery temperature is measured by placing a negative temperature coefficient (NTC) thermistor close to the battery pack.

To use this feature connect the NTC thermistor, R_{NTC} , between the NTC pin and ground and a resistor, R_{NOM} , from V_{BUS} to the NTC pin. R_{NOM} should be a 1% resistor with a value equal to the value of the chosen NTC thermistor at 25°C (R25). A 100k thermistor is recommended since thermistor current is not measured by the LTC3566 family and will have to be budgeted for USB compliance.

The LTC3566 family will pause charging when the resistance of the NTC thermistor drops to 0.54 times the value of R25 or approximately 54k. For Vishay curve 1 thermistor, this corresponds to approximately 40°C. If the battery charger is in constant-voltage (float) mode, the safety timer also pauses until the thermistor indicates a return to a valid temperature. As the temperature drops, the resistance

OPERATION

of the NTC thermistor rises. The LTC3566 family is also designed to pause charging when the value of the NTC thermistor increases to 3.25 times the value of R_{25} . For Vishay curve 1 this resistance, 325k, corresponds to approximately 0°C. The hot and cold comparators each have approximately 3°C of hysteresis to prevent oscillation about the trip point. Grounding the NTC pin disables the NTC charge pausing function.

Thermal Regulation

To optimize charging time, an internal thermal feedback loop may automatically decrease the programmed charge current. This will occur if the die temperature rises to approximately 110°C. Thermal regulation protects the LTC3566 family from excessive temperature due to high power operation or high ambient thermal conditions and allows the user to push the limits of the power handling capability with a given circuit board design without risk of damaging the part or external components. The benefit of the LTC3566 family thermal regulation loop is that charge current can be set according to actual conditions rather than worst-case conditions with the assurance that the battery charger will automatically reduce the current in worst-case conditions.

Buck-Boost DC/DC Switching Regulator

The LTC3566 family contains a 2.25MHz constant-frequency voltage mode buck-boost switching regulator. The regulator provides up to 1A of output load current. The buck-boost can be programmed to a minimum output voltage of 2.75V and can be used to power a microcontroller core, microcontroller I/O, memory, disk drive, or other logic circuitry. To suit a variety of applications, a selectable mode function allows the user to trade off noise for efficiency. Two modes are available to control the operation of the LTC3566 family's buck-boost regulator. At moderate to heavy loads, the constant frequency PWM mode provides the least noise switching solution. At lighter loads Burst Mode operation may be selected. The output voltage is programmed by a user supplied resistive divider returned to the FB1 pin. An error amplifier compares the divided output voltage with a reference and adjusts the compensation voltage accordingly until the FB1 has stabilized at 0.8V. The buck-boost regulator also includes a soft-start to

limit inrush current and voltage overshoot when powering on, short circuit current protection, and switch node slew limiting circuitry for reduced radiated EMI.

Input Current Limit

The input current limit comparator will shut the input PMOS switch off once current exceeds 2.5A (typical). The 2.5A input current limit also protects against a grounded V_{OUT1} node.

Output Overvoltage Protection

If the FB1 node were inadvertently shorted to ground, then the output would increase indefinitely with the maximum current that could be sourced from V_{IN1} . The LTC3566 family protects against this by shutting off the input PMOS if the output voltage exceeds a 5.6V (typical).

Low Output Voltage Operation

When the output voltage is below 2.65V (typical) during start-up, Burst Mode operation is disabled and switch D is turned off (allowing forward current through the well diode and limiting reverse current to 0mA).

Buck-Boost Regulator PWM Operating Mode

In PWM mode the voltage seen at FB1 is compared to a 0.8V reference. From the FB1 voltage an error amplifier generates an error signal seen at V_{C1} . This error signal commands PWM waveforms that modulate switches A, B, C and D. Switches A and B operate synchronously as do switches C and D. If V_{IN1} is significantly greater than the programmed V_{OUT1} , then the converter will operate in buck mode. In this mode switches A and B will be modulated, with switch D always on (and switch C always off), to step-down the input voltage to the programmed output. If V_{IN1} is significantly less than the programmed V_{OUT1} , then the converter will operate in boost mode. In this mode switches C and D are modulated, with switch A always on (and switch B always off), to step-up the input voltage to the programmed output. If V_{IN1} is close to the programmed V_{OUT1} , then the converter will operate in 4-switch mode. In this mode the switches sequence through the pattern of AD, AC, BD to either step the input voltage up or down to the programmed output.

OPERATION

Buck-Boost Regulator Burst Mode Operation

In Burst Mode operation, the buck-boost regulator uses a hysteretic FB1 voltage algorithm to control the output voltage. By limiting FET switching and using a hysteretic control loop, switching losses are greatly reduced. In this mode output current is limited to 50mA typical. While operating in Burst Mode operation, the output capacitor is charged to a voltage slightly higher than the regulation point. The buck-boost converter then goes into a sleep state, during which the output capacitor provides the load current. The output capacitor is charged by charging the inductor until the input current reaches 275mA typical and then discharging the inductor until the reverse current reaches 0mA typical. This process is repeated until the feedback voltage has charged to 6mV above the regulation point. In the sleep state, most of the regulator's circuitry is powered down, helping to conserve battery power. When the feedback voltage drops 6mV below the regulation point, the switching regulator circuitry is powered on and another burst cycle begins. The duration for which the regulator sleeps depends on the load current and output capacitor value. The sleep time decreases as the load current increases. The maximum load current in Burst Mode operation is 50mA. The buck-boost regulator will not go to sleep if the current is greater than 50mA and if the load current increases beyond this point while in Burst Mode operation the output will lose regulation. Burst Mode operation provides a significant improvement in efficiency at light loads at the expense of higher output ripple when compared to PWM mode. For many noise-sensitive systems, Burst Mode operation might be undesirable at certain times (i.e. during a transmit or receive cycle of a wireless device), but highly desirable at others (i.e. when the device is in low power standby mode). The MODE pin is used to enable or disable Burst Mode operation at any time, offering both low noise and low power operation when they are needed.

Buck-Boost Regulator Soft-Start Operation

Soft-start is accomplished by gradually increasing the reference voltage input to the error amplifier over a 0.5ms (typical) period. This limits transient inrush currents during start-up because the output voltage is always in regulation. Ramping the reference voltage input also limits the rate of increase in the V_{C1} voltage which helps minimize output overshoot during start-up. A soft-start cycle occurs whenever the buck-boost is enabled, or after a fault condition has occurred (thermal shutdown or UVLO). A soft-start cycle is not triggered by changing operating modes. This allows seamless operation when transitioning between Burst Mode operation and PWM mode.

Low Supply Operation

The LTC3566 family incorporates an undervoltage lockout circuit on V_{OUT} (connected to V_{IN1}) which shuts down the buck-boost regulator when V_{OUT} drops below 2.6V. This UVLO prevents unstable operation.

Table 2. USB Current Limit Settings

| ILIM1 | ILIM0 | USB SETTING |
|-------|-------|---------------------------|
| 0 | 0 | 1x Mode (USB 100mA Limit) |
| 0 | 1 | 10x Mode (Wall 1A Limit) |
| 1 | 0 | Suspend |
| 1 | 1 | 5x Mode (USB 500mA Limit) |

Table 3. Switching Regulator Modes

| MODE | SWITCHING REGULATOR MODE |
|------|--------------------------|
| 0 | PWM Mode |
| 1 | Burst Mode Operation |

APPLICATIONS INFORMATION

CLPROG Resistor and Capacitor

As described in the High Efficiency Switching PowerPath Controller section, the resistor on the CLPROG pin determines the average input current limit when the switching regulator is set to either the 1x mode (USB 100mA), the 5x mode (USB 500mA) or the 10x mode. The input current will be comprised of two components, the current that is used to drive V_{OUT} and the quiescent current of the switching regulator. To ensure that the total average input current remains below the USB specification, both components of input current should be considered. The Electrical Characteristics table gives values for quiescent currents in either setting as well as current limit programming accuracy. To get as close to the 500mA or 100mA specifications as possible, a 1% resistor should be used. Recall that $I_{VBUS} = I_{VBUSQ} + V_{CLPROG}/R_{CLPROG} \cdot (h_{CLPROG} + 1)$.

An averaging capacitor or an R-C combination is required in parallel with the CLPROG resistor so that the switching regulator can determine the average input current. This network also provides the dominant pole for the feedback loop when current limit is reached. To ensure stability, the capacitor on CLPROG should be 0.1 μ F or larger.

Choosing the PowerPath Inductor

Because the input voltage range and output voltage range of the PowerPath switching regulator are both fairly narrow, the LTC3566 family was designed for a specific inductance value of 3.3 μ H. Some inductors which may be suitable for this application are listed in Table 4.

Table 4. Recommended Inductors for PowerPath Controller

| INDUCTOR TYPE | L (μ H) | MAX IDC (A) | MAX DCR (Ω) | SIZE IN mm (L x W x H) | MANUFACTURER |
|-------------------|--------------|-------------|----------------------|------------------------|---------------------------------------|
| LPS4018 | 3.3 | 2.2 | 0.08 | 3.9 x 3.9 x 1.7 | CoilCraft www.coilcraft.com |
| D53LC | 3.3 | 2.26 | 0.034 | 5.0 x 5.0 x 3.0 | Toko |
| DB318C | 3.3 | 1.55 | 0.070 | 3.8 x 3.8 x 1.8 | www.toko.com |
| WE-TPC Type M1 | 3.3 | 1.95 | 0.065 | 4.8 x 4.8 x 1.8 | Würth Elektronik www.we-online.com |
| CDRH6D12 | 3.3 | 2.2 | 0.0625 | 6.7 x 6.7 x 1.5 | Sumida |
| CDRH6D38 | 3.3 | 3.5 | 0.020 | 7.0 x 7.0 x 4.0 | www.sumida.com |

APPLICATIONS INFORMATION

Buck-Boost Regulator Inductor Selection

Many different sizes and shapes of inductors are available from numerous manufacturers. Choosing the right inductor from such a large selection of devices can be overwhelming, but following a few basic guidelines will make the selection process much simpler.

The buck-boost converter is designed to work with inductors in the range of 1 μ H to 5 μ H. For most applications a 2.2 μ H inductor will suffice. Larger value inductors reduce ripple current which improves output ripple voltage. Lower value inductors result in higher ripple current and improved transient response time. To maximize efficiency, choose an inductor with a low DC resistance. For a 3.3V output, efficiency is reduced about 3% for a 100m Ω series resistance at 1A load current, and about 2% for 300m Ω series resistance at 200mA load current. Choose an inductor with a DC current rating at least 2 times larger than the maximum load current to ensure that the inductor does not saturate during normal operation. If output short circuit is a possible condition, the inductor should be rated to handle the 2.5A maximum peak current specified for the buck-boost converter.

Different core materials and shapes will change the size/current and price/current relationship of an inductor. Toroid or shielded pot cores in ferrite or Permalloy materials are small and do not radiate much energy, but generally cost more than powdered iron core inductors with similar electrical characteristics. Inductors that are very thin or have a very small volume typically have much higher core and DCR losses, and will not give the best efficiency. The choice of which style inductor to use often depends more on the price vs size, performance and any radiated EMI requirements than on what the LTC3566 family requires to operate.

The inductor value also has an effect on Burst Mode operation. Lower inductor values will cause the Burst Mode operation switching frequencies to increase.

Table 5 shows several inductors that work well with the LTC3566 family's buck-boost regulator. These inductors offer a good compromise in current rating, DCR and physical size. Consult each manufacturer for detailed information on their entire selection of inductors.

Table 5. Recommended Inductors for Buck-Boost Regulator

| INDUCTOR TYPE | L (μ H) | MAX I _{DC} (A) | MAX DCR (Ω) | SIZE IN mm (L \times W \times H) | MANUFACTURER |
|---------------|--------------|-------------------------|----------------------|--|---------------------------------------|
| LPS4018 | 3.3 2.2 | 2.2 2.5 | 0.08 0.07 | 3.9 \times 3.9 \times 1.7 3.9 \times 3.9 \times 1.7 | Coilcraft www.coilcraft.com |
| D53LC | 2.0 | 3.25 | 0.02 | 5.0 \times 5.0 \times 3.0 | Toko www.toko.com |
| 7440430022 | 2.2 | 2.5 | 0.028 | 4.8 \times 4.8 \times 2.8 | Würth Elektronik www.we-online.com |
| CDRH4D22/HP | 2.2 | 2.4 | 0.044 | 4.7 \times 4.7 \times 2.4 | Sumida www.sumida.com |
| SD14 | 2.0 | 2.56 | 0.045 | 5.2 \times 5.2 \times 1.45 | Cooper www.cooperet.com |

APPLICATIONS INFORMATION

V_{BUS} and V_{OUT} Bypass Capacitors

The style and value of capacitors used with the LTC3566 family determine several important parameters such as regulator control-loop stability and input voltage ripple. Because the LTC3566 family uses a step-down switching power supply from V_{BUS} to V_{OUT} , its input current waveform contains high frequency components. It is strongly recommended that a low equivalent series resistance (ESR) multilayer ceramic capacitor be used to bypass V_{BUS} . Tantalum and aluminum capacitors are not recommended because of their high ESR. The value of the capacitor on V_{BUS} directly controls the amount of input voltage ripple for a given load current. Increasing the size of this capacitor will reduce the input voltage ripple.

To prevent large V_{OUT} voltage steps during transient load conditions, it is also recommended that a ceramic capacitor be used to bypass V_{OUT} . The output capacitor is used in the compensation of the switching regulator. At least 4 μ F of actual capacitance with low ESR are required on V_{OUT} . Additional capacitance will improve load transient performance and stability.

Multilayer ceramic chip capacitors typically have exceptional ESR performance. MLCCs combined with a tight board layout and an unbroken ground plane will yield very good performance and low EMI emissions.

There are several types of ceramic capacitors available, each having considerably different characteristics. For example, X7R ceramic capacitors have the best voltage and temperature stability. X5R ceramic capacitors have apparently higher packing density but poorer performance over their rated voltage and temperature ranges. Y5V ceramic capacitors have the highest packing density, but must be used with caution, because of their extreme nonlinear characteristic of capacitance vs voltage. The actual in-circuit capacitance of a ceramic capacitor should be measured with a small AC signal (ideally less than 200mV) as is expected in-circuit. Many vendors specify the capacitance vs voltage with a 1V_{RMS} AC test signal and as a result overstate the capacitance that the capacitor will present in the application. Using similar operating conditions as the application, the user must measure or request

from the vendor the actual capacitance to determine if the selected capacitor meets the minimum capacitance that the application requires.

Buck-Boost Regulator Input/Output Capacitor Selection

Low ESR MLCC capacitors should be used at both the buck-boost regulator output (V_{OUT1}) and the buck-boost regulator input supply (V_{IN1}). Only X5R or X7R ceramic capacitors should be used because they retain their capacitance over wider voltage and temperature ranges than other ceramic types. A 22 μ F output capacitor is sufficient for most applications. The buck-boost regulator input supply should be bypassed with a 2.2 μ F capacitor. Consult with capacitor manufacturers for detailed information on their selection and specifications of ceramic capacitors. Many manufacturers now offer very thin (<1mm tall) ceramic capacitors ideal for use in height restricted designs. Table 6 shows a list of several ceramic capacitor manufacturers.

Table 6. Recommended Ceramic Capacitor Manufacturers

| MANUFACTURER | WEBSITE |
|------------------|--|
| AVX | www.avxcorp.com |
| Murata | www.murata.com |
| Taiyo Yuden | www.t-yuden.com |
| Vishay Siliconix | www.vishay.com |
| TDK | www.tdk.com |

Over-Programming the Battery Charger

The USB high power specification allows for up to 2.5W to be drawn from the USB port (5V x 500mA). The PowerPath switching regulator transforms the voltage at V_{BUS} to just above the voltage at BAT with high efficiency, while limiting power to less than the amount programmed at CLPROG. In some cases the battery charger may be programmed (with the PROG pin) to deliver the maximum safe charging current without regard to the USB specifications. If there is insufficient current available to charge the battery at the programmed rate, the PowerPath regulator will reduce charge current until the system load on V_{OUT} is satisfied

APPLICATIONS INFORMATION

and the V_{BUS} current limit is satisfied. Programming the battery charger for more current than is available will not cause the average input current limit to be violated. It will merely allow the battery charger to make use of all available power to charge the battery as quickly as possible, and with minimal power dissipation within the battery charger.

Alternate NTC Thermistors and Biasing

The LTC3566 family provides temperature qualified charging if a grounded thermistor and a bias resistor are connected to NTC. By using a bias resistor whose value is equal to the room temperature resistance of the thermistor (R_{25}) the upper and lower temperatures are pre-programmed to approximately 40°C and 0°C, respectively (assuming a Vishay curve 1 thermistor).

The upper and lower temperature thresholds can be adjusted by either a modification of the bias resistor value or by adding a second adjustment resistor to the circuit. If only the bias resistor is adjusted, then either the upper or the lower threshold can be modified but not both. The other trip point will be determined by the characteristics of the thermistor. Using the bias resistor in addition to an adjustment resistor, both the upper and the lower temperature trip points can be independently programmed with the constraint that the difference between the upper and lower temperature thresholds cannot decrease. Examples of each technique follow.

NTC thermistors have temperature characteristics which are indicated on resistance-temperature conversion tables. The Vishay-Dale thermistor NTHS0603N011-N1003F, used in the following examples, has a nominal value of 100k and follows the Vishay curve 1 resistance-temperature characteristic.

In the explanation below, the following notation is used.

R_{25} = Value of the thermistor at 25°C

$R_{NTC|COLD}$ = Value of thermistor at the cold trip point

$R_{NTC|HOT}$ = Value of thermistor at the hot trip point

r_{COLD} = Ratio of $R_{NTC|COLD}$ to R_{25}

r_{HOT} = Ratio of $R_{NTC|HOT}$ to R_{25}

R_{NOM} = Primary thermistor bias resistor (see Figure 4a)

$R1$ = Optional temperature range adjustment resistor (see Figure 4b)

The trip points for the LTC3566 family's temperature qualification are internally programmed at $0.349 \cdot V_{BUS}$ for the hot threshold and $0.765 \cdot V_{BUS}$ for the cold threshold.

Therefore, the hot trip point is set when:

$$\frac{R_{NTC|HOT}}{R_{NOM} + R_{NTC|HOT}} \cdot V_{BUS} = 0.349 \cdot V_{BUS}$$

and the cold trip point is set when:

$$\frac{R_{NTC|COLD}}{R_{NOM} + R_{NTC|COLD}} \cdot V_{BUS} = 0.765 \cdot V_{BUS}$$

Solving these equations for $R_{NTC|COLD}$ and $R_{NTC|HOT}$ results in the following:

$$R_{NTC|HOT} = 0.536 \cdot R_{NOM}$$

and

$$R_{NTC|COLD} = 3.25 \cdot R_{NOM}$$

By setting R_{NOM} equal to R_{25} , the above equations result in $r_{HOT} = 0.536$ and $r_{COLD} = 3.25$. Referencing these ratios to the Vishay Resistance-Temperature Curve 1 chart gives a hot trip point of about 40°C and a cold trip point of about 0°C. The difference between the hot and cold trip points is approximately 40°C.

By using a bias resistor, R_{NOM} , different in value from R_{25} , the hot and cold trip points can be moved in either direction. The temperature span will change somewhat due to the nonlinear behavior of the thermistor. The following equations can be used to easily calculate a new value for the bias resistor:

$$R_{NOM} = \frac{r_{HOT}}{0.536} \cdot R_{25}$$

$$R_{NOM} = \frac{r_{COLD}}{3.25} \cdot R_{25}$$

APPLICATIONS INFORMATION

where r_{HOT} and r_{COLD} are the resistance ratios at the desired hot and cold trip points. Note that these equations are linked. Therefore, only one of the two trip points can be chosen, the other is determined by the default ratios designed in the IC. Consider an example where a 60°C hot trip point is desired.

From the Vishay curve 1 R-T characteristics, r_{HOT} is 0.2488 at 60°C. Using the above equation, R_{NOM} should be set to 46.4k. With this value of R_{NOM} , the cold trip point is about 16°C. Notice that the span is now 44°C rather than the previous 40°C. This is due to the decrease in temperature gain of the thermistor as absolute temperature increases.

The upper and lower temperature trip points can be independently programmed by using an additional bias resistor as shown in Figure 4b. The following formulas can be used to compute the values of R_{NOM} and R1:

$$R_{NOM} = \frac{r_{COLD} - r_{HOT}}{2.714} \cdot R_{25}$$

$$R1 = 0.536 \cdot R_{NOM} - r_{HOT} \cdot R_{25}$$

For example, to set the trip points to 0°C and 45°C with a Vishay curve 1 thermistor choose:

$$R_{NOM} = \frac{3.266 - 0.4368}{2.714} \cdot 100k = 104.2k$$

The nearest 1% value is 105k

$$R1 = 0.536 \cdot 105k - 0.4368 \cdot 100k = 12.6k$$

The nearest 1% value is 12.7k. The final solution is shown in Figure 4b and results in an upper trip point of 45°C and a lower trip point of 0°C.

USB Inrush Limiting

When a USB cable is plugged into a portable product, the inductance of the cable and the high-Q ceramic input capacitor form an L-C resonant circuit. If the cable does not have adequate mutual coupling or if there is not much impedance in the cable, it is possible for the voltage at the input of the product to reach as high as twice the USB voltage (~10V) before it settles out. To prevent excessive voltage from damaging the LTC3566 family during a hot insertion, it is best to have a low voltage coefficient capacitor at the V_{BUS} pin to the LTC3566 family. This is achievable by selecting an MLCC capacitor that has a higher voltage rating than that required for the application. For example, a 16V, X5R, 10µF capacitor in a 1206 case would be a more conservative choice than a 6.3V, X5R, 10µF capacitor in a

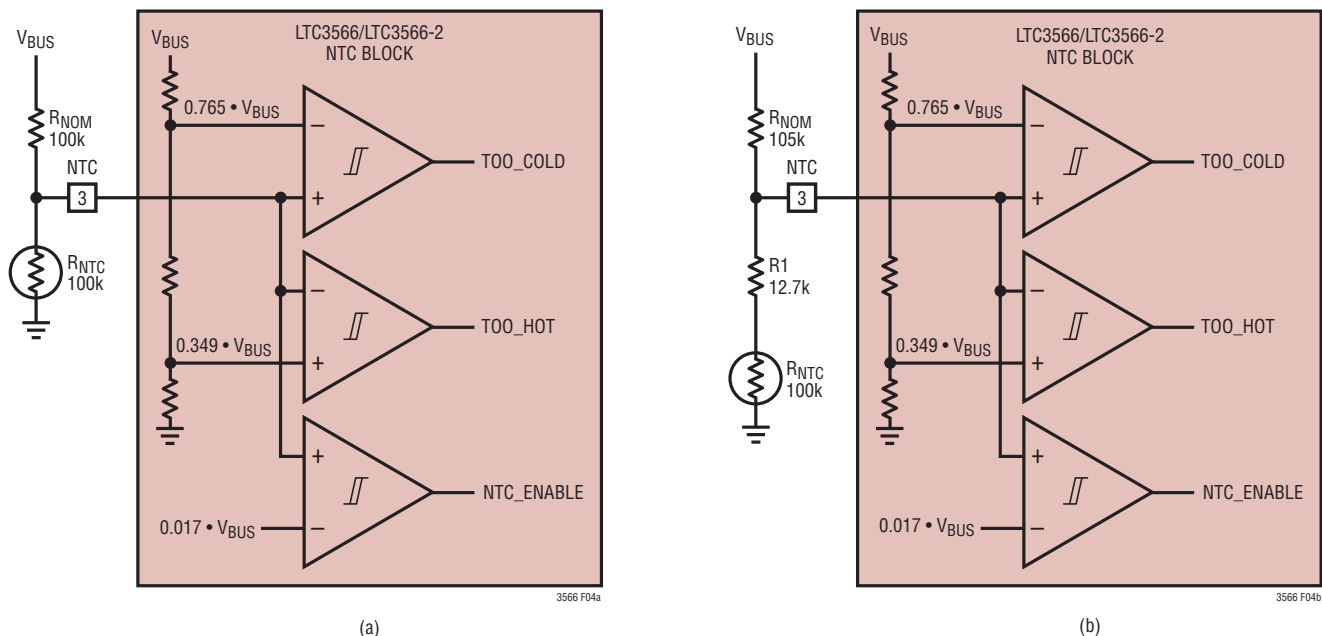

Figure 4. NTC Circuits

APPLICATIONS INFORMATION

smaller 0805 case. The size of the input overshoot will be determined by the Q of the resonant tank circuit formed by C_{IN} and the input lead inductance. It is recommended to measure the input ringing with the selected components to verify compliance with the Absolute Maximum specifications.

Alternatively, the following soft connect circuit (Figure 5) can be employed. In this circuit, capacitor C1 holds MP1 off when the cable is first connected. Eventually C1 begins to charge up to the USB input voltage applying increasing gate support to MP1. The long time constant of R1 and C1 prevent the current from building up in the cable too fast thus dampening out any resonant overshoot.

Buck-Boost Regulator Output Voltage Programming

The buck-boost regulator can be programmed for output voltages greater than 2.75V and less than 5.5V. The output voltage is programmed using a resistor divider from the V_{OUT1} pin connected to the FB1 pin such that:

$$V_{OUT1} = V_{FB1} \left(\frac{R1}{R_{FB}} + 1 \right)$$

where V_{FB1} is fixed at 0.8V (see Figure 6).

Closing the Feedback Loop

The LTC3566 family incorporates voltage mode PWM control. The control to output gain varies with operation region (buck, boost, buck-boost), but is usually no greater than 20. The output filter exhibits a double pole response given by:

$$f_{FILTER_POLE} = \frac{1}{2 \cdot \pi \cdot \sqrt{L \cdot C_{OUT}}} \text{ Hz}$$

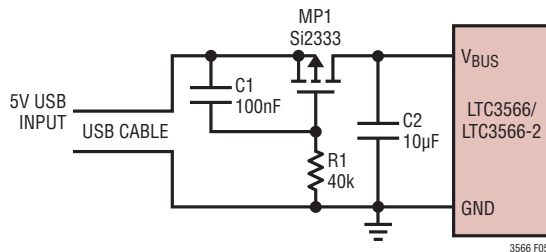

Figure 5. USB Soft Connect Circuit

Where C_{OUT} is the output filter capacitor.

The output filter zero is given by:

$$f_{FILTER_ZERO} = \frac{1}{2 \cdot \pi \cdot R_{ESR} \cdot C_{OUT}} \text{ Hz}$$

where R_{ESR} is the capacitor equivalent series resistance.

A troublesome feature in boost mode is the right-half plane zero (RHP), and is given by:

$$f_{RHPZ} = \frac{V_{IN1}^2}{2 \cdot \pi \cdot I_{OUT} \cdot L \cdot V_{OUT1}} \text{ Hz}$$

The loop gain is typically rolled off before the RHP zero frequency.

A simple Type I compensation network (as shown in Figure 6), can be incorporated to stabilize the loop but at the cost of reduced bandwidth and slower transient response. To ensure proper phase margin, the loop must cross unity-gain a decade before the LC double pole.

The unity-gain frequency of the error amplifier with the Type I compensation is given by:

$$f_{UG} = \frac{1}{2 \cdot \pi \cdot R1 \cdot C_{P1}} \text{ Hz}$$

Most applications demand an improved transient response to allow a smaller output filter capacitor. To achieve a higher bandwidth, Type III compensation is required. Two zeros are required to compensate for the double-pole response. Type III compensation also reduces any V_{OUT1} overshoot seen at start-up.

The compensation network depicted in Figure 7 yields the transfer function:

$$\frac{V_{C1}}{V_{OUT1}} = \frac{1}{R1 \cdot (C1 + C2)} \cdot \frac{(1 + sR2C2) \cdot (1 + s(R1 + R3)C3)}{s \cdot \left(1 + \frac{sR2C1C2}{C1 + C2} \right) \cdot (1 + sR3C3)}$$

APPLICATIONS INFORMATION

A Type III compensation network attempts to introduce a phase bump at a higher frequency than the LC double pole. This allows the system to cross unity gain after the LC double pole, and achieve a higher bandwidth. While attempting to cross over after the LC double pole, the system must still cross over before the boost right-half plane zero. If unity gain is not reached sufficiently before the right-half plane zero, then the -180° of phase lag from the LC double pole combined with the -90° of phase lag from the right-half plane zero will result in negating the phase bump of the compensator.

The compensator zeros should be placed either before or only slightly after the LC double pole such that their positive phase contributions offset the -180° that occurs at the filter double pole. If they are placed at too low of a frequency, they will introduce too much gain to the system and the crossover frequency will be too high. The two high frequency poles should be placed such that the system crosses unity gain during the phase bump introduced by the zeros and before the boost right-half plane zero and such that the compensator bandwidth is less than the bandwidth of the error amp (typically 900 kHz). If the gain of the compensation network is ever greater than the gain of the error amplifier, then the error amplifier no longer acts as an ideal op amp, another pole will be introduced and at the same point.

Recommended Type III compensation components for a 3.3V output:

R1: 324k Ω

R_{FB}: 105k Ω

C1: 10pF

R2: 15k Ω

C2: 330pF

R3: 121k Ω

C3: 33pF

C_{OUT}: 22 μ F

L_{OUT}: 2.2 μ H

Printed Circuit Board Layout Considerations

In order to be able to deliver maximum current under all conditions, it is critical that the Exposed Pad on the backside of the LTC3566 family package be soldered to the PC board ground. Failure to make thermal contact between the Exposed Pad on the backside of the package and the copper board will result in higher thermal resistances.

Furthermore, due to its high frequency switching circuitry, it is imperative that the input capacitors, inductors, and output capacitors be as close to the LTC3566 family as

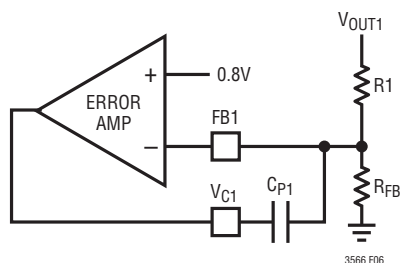

Figure 6. Error Amplifier with Type I Compensation

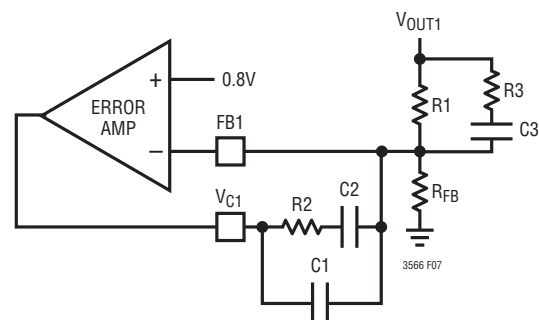

Figure 7. Error Amplifier with Type III Compensation

APPLICATIONS INFORMATION

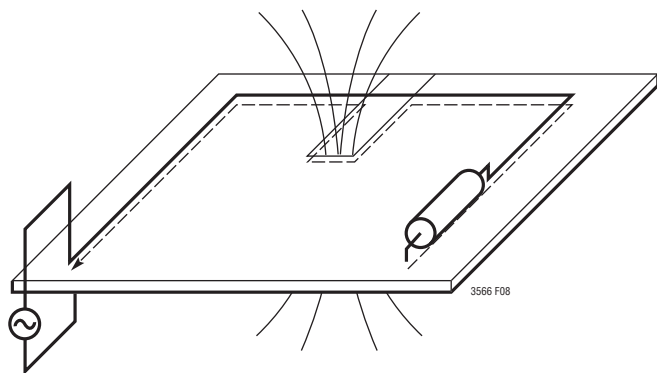

Figure 8. Higher Frequency Ground Currents Follow Their Incident Path. Slits in the Ground Plane Cause High Voltage and Increased Emissions.

possible and that there be an unbroken ground plane under the IC and all of its external high frequency components. High frequency currents, such as the V_{BUS} , V_{IN1} , and V_{OUT1} currents on the LTC3566 family, tend to find their way along the ground plane in a myriad of paths ranging from directly back to a mirror path beneath the incident path on the top of the board. If there are slits or cuts in the ground plane due to other traces on that layer, the current will be forced to go around the slits. If high frequency currents are not allowed to flow back through their natural least-area path, excessive voltage will build up and radiated emissions will occur. There should be a group of vias under the grounded backside of the package leading directly down to an internal ground plane. To minimize parasitic inductance, the ground plane should be on the second layer of the PC board.

The GATE pin for the external ideal diode controller has extremely limited drive current. Care must be taken to minimize leakage to adjacent PC board traces. 100nA of leakage from this pin will introduce an offset to the 15mV ideal diode of approximately 10mV. To minimize leakage, the trace can be guarded on the PC board by surrounding it with V_{OUT} connected metal, which should generally be less than one volt higher than GATE.

When laying out the printed circuit board, the following checklist should be used to ensure proper operation of the LTC3566 family.

1. Are the capacitors at V_{BUS} , V_{IN1} , and V_{OUT1} as close as possible to the LTC3566? These capacitors provide the AC current to the internal power MOSFETs and their drivers. Minimizing inductance from these capacitors to the LTC3566 is a top priority.
2. Are C_{OUT} and L1 closely connected? The (-) plate of C_{OUT} returns current to the GND plane, and then back to C_{IN} .
3. Keep sensitive components away from the SW pins.

Battery Charger Stability Considerations

The LTC3566 family's battery charger contains both a constant-voltage and a constant-current control loop. The constant-voltage loop is stable without any compensation when a battery is connected with low impedance leads. Excessive lead length, however, may add enough series inductance to require a bypass capacitor of at least 1 μ F from BAT to GND. Furthermore, when the battery is disconnected, a 4.7 μ F capacitor in series with a 0.2 Ω to 1 Ω resistor from BAT to GND is required to keep ripple voltage low.

High value, low ESR multilayer ceramic chip capacitors reduce the constant-voltage loop phase margin, possibly resulting in instability. Ceramic capacitors up to 22 μ F may be used in parallel with a battery, but larger ceramics should be decoupled with 0.2 Ω to 1 Ω of series resistance.

In constant-current mode, the PROG pin is in the feedback loop rather than the battery voltage. Because of the additional pole created by any PROG pin capacitance, capacitance on this pin must be kept to a minimum. With no additional capacitance on the PROG pin, the battery charger is stable with program resistor values as high as 25k. However, additional capacitance on this node reduces the maximum allowed program resistor. The pole frequency at the PROG pin should be kept above 100kHz. Therefore, if the PROG pin has a parasitic capacitance, C_{PROG} , the following equation should be used to calculate the maximum resistance value for R_{PROG} :

$$R_{PROG} \leq \frac{1}{2\pi \cdot 100\text{kHz} \cdot C_{PROG}}$$

TYPICAL APPLICATIONS

Direct Pin Controlled LTC3566/LTC3566-2 USB Power Manager with 3.3V/1A Buck-Boost

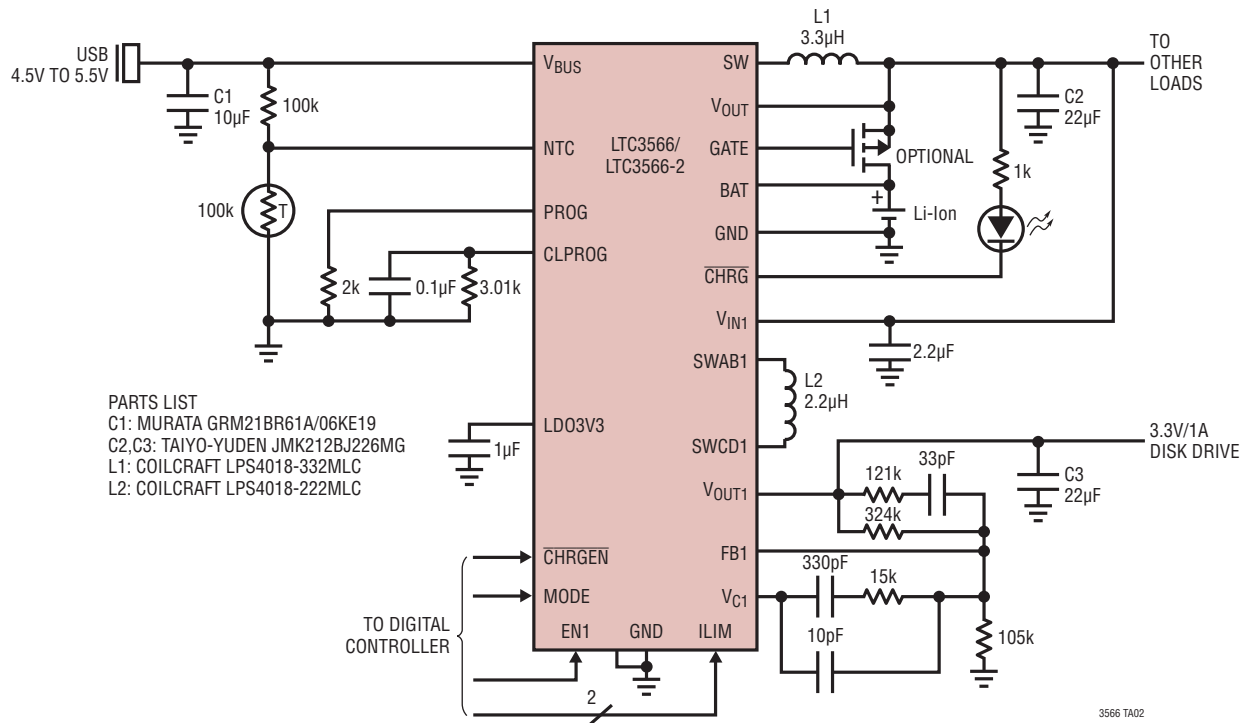

PACKAGE DESCRIPTION

UF Package
24-Lead Plastic QFN (4mm × 4mm)
 (Reference LTC DWG # 05-08-1697 Rev B)

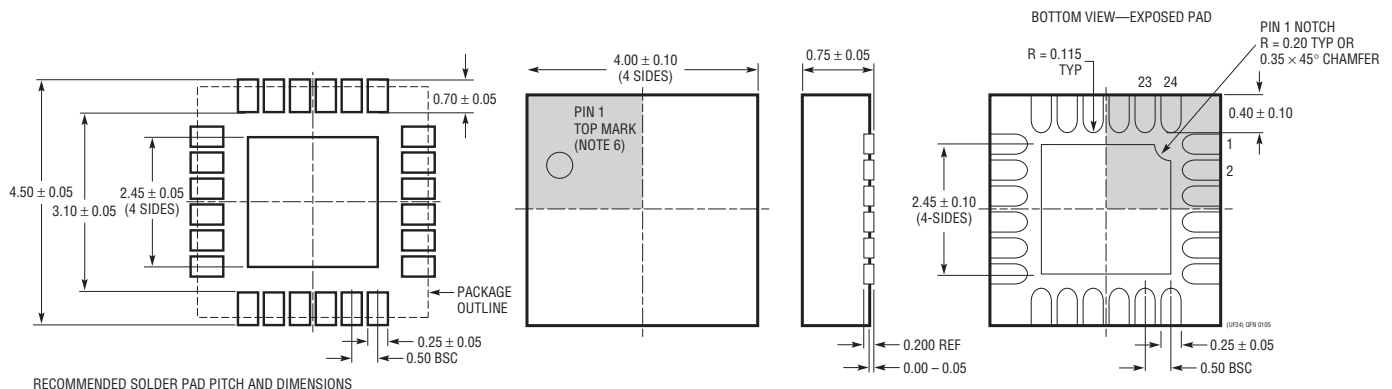

- NOTE:**
1. DRAWING PROPOSED TO BE MADE A JEDEC PACKAGE OUTLINE MO-220 VARIATION (WGGD-X)—TO BE APPROVED
 2. DRAWING NOT TO SCALE
 3. ALL DIMENSIONS ARE IN MILLIMETERS
 4. DIMENSIONS OF EXPOSED PAD ON BOTTOM OF PACKAGE DO NOT INCLUDE MOLD FLASH. MOLD FLASH, IF PRESENT, SHALL NOT EXCEED 0.15mm ON ANY SIDE, IF PRESENT
 5. EXPOSED PAD SHALL BE SOLDER PLATED
 6. SHADED AREA IS ONLY A REFERENCE FOR PIN 1 LOCATION ON THE TOP AND BOTTOM OF PACKAGE

LTC3566/LTC3566-2

RELATED PARTS

| PART NUMBER | DESCRIPTION | COMMENTS |
|-------------------------------------|--|--|
| LTC3440 | 600mA (I_{OUT}), 2MHz Synchronous Buck-Boost DC/DC Converter | V_{IN} : 2.5V to 5.5V, V_{OUT} : 2.5V to 5.5V I_Q = 25 μ A, ISD < 1 μ A, MS, DFN Package |
| LTC3441/ LTC3442 | 1.2A (I_{OUT}), Synchronous Buck-Boost DC/DC Converters, LTC3441 (1MHz), LTC3443 (600kHz) | V_{IN} : 2.5V to 5.5V, V_{OUT} : 2.4V to 5.25V I_Q = 25 μ A, ISD < 1 μ A, MS, DFN Package |
| LTC3442 | 1.2A (I_{OUT}), 2MHz Synchronous Buck-Boost DC/DC Converter | V_{IN} : 2.4V to 5.5V, V_{OUT} : 2.4V to 5.25V I_Q = 28 μ A, ISD < 1 μ A, MS Package |
| LTC3455 | Dual DC/DC Converter with USB Power Management and Li-Ion Battery Charger | Efficiency >96%, Accurate USB Current Limiting (500mA/100mA), 4mm \times 4mm QFN-24 Package |
| LTC3538 | 800mA, 2MHz Synchronous Buck-Boost DC/DC Converter | V_{IN} : 2.4V to 5.5V, V_{OUT} : 1.8V to 5.25V I_Q = 35 μ A, 2mm \times 3mm DFN-8 Package |
| LTC3550 | Dual Input USB/AC Adapter Li-Ion Battery Charger with adjustable output 600mA Buck Converter | Synchronous Buck Converter, Efficiency: 93%, Adjustable Output at 600mA; Charge Current: 950mA Programmable, USB Compatible, Automatic Input Power Detection and Selection, 3mm \times 5mm DFN-16 Package |
| LTC3550-1 | Dual Input USB/AC Adapter Li-Ion Battery Charger with 600mA Buck Converter | Synchronous Buck Converter, Efficiency: 93%, Output: 1.875V at 600mA; Charge Current: 950mA Programmable, USB Compatible, Automatic Input Power Detection and Selection, 3mm \times 5mm DFN-16 Package |
| LTC3552 | Standalone Linear Li-Ion Battery Charger with Adjustable Output Dual Synchronous Buck Converter | Synchronous Buck Converter, Efficiency: >90%, Adjustable Outputs at 800mA and 400mA; Charge Current Programmable Up to 950mA, USB Compatible, 3mm \times 5mm DFN-16 Package |
| LTC3552-1 | Standalone Linear Li-Ion Battery Charger with Dual Synchronous Buck Converter | Synchronous Buck Converter, Efficiency: >90%, Output: 1.8V at 800mA, 1.575V at 400mA; Charge Current Programmable Up to 950mA, USB Compatible, 3mm \times 5mm DFN-16 Package |
| LTC3555/ LTC3555-1/ LTC3555-3 | Switching USB Power Manager with Li-Ion/ Polymer Charger, Triple Synchronous Buck Converter Plus LDO | Complete Multi-Function PMIC: Switchmode Power Manager and Three Buck Regulators Plus LDO; Charge Current Programmable Up to 1.5A from Wall Adapter Input, Thermal Regulation, Synchronous Buck Converters Efficiency: >95%, ADJ Outputs: 0.8V to 3.6V at 400mA/400mA/1A Bat-Track Adaptive Output Control, 200m Ω Ideal Diode, 4mm \times 5mm QFN-28 Package |
| LTC3556 | Switching USB Power Manager with Li-Ion/ Polymer Charger, 1A Buck-Boost + Dual Sync Buck Converter + LDO | Complete Multi-Function PMIC: Switching Power Manager, 1A Buck-Boost + 2 Buck Regulators + LDO, ADJ Out Down to 0.8V at 400mA/400mA/1A, Synchronous Buck/ Buck-Boost Converter Efficiency: >95%; Charge Current Programmable up to 1.5A from Wall Adapter Input, Thermal Regulation, Bat-Track Adaptive Output Control, 180m Ω Ideal Diode, 4mm \times 5mm QFN-28 Package |
| LTC3557/ LTC3557-1 | USB Power Manager with Li-Ion/Polymer Charger, Triple Synchronous Buck Converter Plus LDO | Complete Multi-Function PMIC: Linear Power Manager and Three Buck Regulators, Charge Current Programmable Up to 1.5A from Wall Adapter Input, Thermal Regulation, Synchronous Buck Converters Efficiency: >95%, ADJ Output: 0.8V to 3.6V at 400mA/ 400mA/600mA, Bat-Track Adaptive Output Control, 200m Ω Ideal Diode, 4mm \times 4mm QFN-28 Package |
| LTC3559 | Linear USB Li-Ion/Polymer Battery Charger with Dual Synchronous Buck Converters | Adjustable Synchronous Buck Converters, Efficiency: >90%, Outputs: Down to 0.8V at 400mA for Each, Charge Current Programmable Up to 950mA, USB Compatible, 3mm \times 3mm QFN-16 Package |
| LTC4055 | USB Power Controller and Battery Charger | Charges Single-Cell Li-Ion Batteries Directly From USB Port, Thermal Regulation, 4mm \times 4mm QFN-16 Package |
| LTC4067 | Linear USB Power Manager with OVP, Ideal Diode Controller and Li-Ion Charger | 13V Overvoltage Transient Protection, Thermal Regulation 200m Ω Ideal Diode with <50m Ω Option, 3mm \times 4mm QFN-14 Package |
| LTC4085 | Linear USB Power Manager with Ideal Diode Controller and Li-Ion Charger | Charges Single Cell Li-Ion Batteries Directly from a USB Port, Thermal Regulation, 200m Ω Ideal Diode with <50m Ω Option, 3mm \times 4mm QFN-14 Package |
| LTC4088/ LTC4088-1/ LTC4088-2 | High Efficiency USB Power Manager and Battery Charger | Maximizes Available Power from USB Port, Bat-Track, Instant-On Operation, 1.5A Maximum Charge Current, 180m Ω Ideal Diode with <50m Ω Option, 3.3V/25mA Always-On LDO, 3mm \times 4mm DFN-14 Package |
| LTC4090 | High Voltage USB Power Manager with Ideal Diode Controller and High Efficiency Li-Ion Battery Charger | High Efficiency 1.2A Charger from 6V to 38V (60V Maximum) Input Charges Single Cell Li-Ion Batteries Directly from a USB Port, Thermal Regulation; 200m Ω Ideal Diode with <50m Ω option, 3mm \times 6mm DFN-22 Package Bat-Track Adaptive Output Control |

3566fb