

PRODUCT INFORMATION

FEATURES

- (1) 12.1"XGA(1024x768 pixels) display size for notebook PC
- (2) High Brightness (200cd/m² @6mA)
- (3) LVDS interface system (H-Sync, V-Sync)

TENTATIVE

MECHANICAL SPECIFICATIONS

Item	Specifications
Dimensional Outline (typ.)	261.0(W) x 199.0 (H) x 5.2max(D) mm
Number of Pixels	1024(W) x 768(H) pixels
Active Area	245.76(W) x 184.32(H) mm
Pixel Pitch	0.24(W) x 0.24(H)
Weight (approximately)	(270) g
Backlight	Single CCFL, Sidelight type

ABSOLUTE MAXIMUM RATINGS

Item	Min.	Max.	Unit
Supply Voltage (V_{DD})	-0.3	4.0	V
(V_{FL})	0	2.0	kV(rms)
FL Driving Frequency (f_{FL})	-	100	kHz
Input Signal Voltage (V_{IN})	-0.3	$V_{DD}+0.3$	V
Operating Temperature	0	50	°C
Storage Temperature	-20	60	°C
Storage Humidity	10	90	% (RH)

ELECTRICAL SPECIFICATION

Item	Min.	Typ.	Max.	Unit	Remarks	
Supply Voltage	(V_{DD})	3.0	3.3	3.6	V	
	(V_{FL})	---	(620)	---	V(rms)	$I_{FL}=6.0$ mA(rms)
FL Start Voltage ($T_a=0^\circ\text{C}$)	1400	---	---	V(rms)		
Differential Input Voltage	(V_{IP})	100	---	600	mV	
Comon Mode Input Voltage	(V_{CM})	1.0	---	$2.4-(V_{IP})/2$	V	
Current Consumption	*1 (I_{DD})	---	195	---	mA	
	*2 (I_{FL})	---	6.0	---	mA(rms)	
*2 *3 Power Consumption	---	(4.36)	---	W	$I_{FL}=6.0$ mA(rms)	

*1 : 8 color bars pattern

*2 : Excepting the efficiency FL inverter

OPTICAL SPECIFICATION ($T_a=25^\circ\text{C}$)

Item	Min.	Typ.	Max.	Unit	Remarks
Contrast Ratio (CR)	150	(400)	---	---	
Response Time	(t_{ON})	---	50	ms	
	(t_{OFF})	---	50	ms	
Luminance (L)	---	200	---	cd/m ²	$I_{FL}=6.0$ mA(rms)

*The information contained herein is presented only as a guide for the applications of our products. No responsibility is assumed by Toshiba Matsushita Display technology or other rights of the third parties which may result from its use. No license is granted by implication or otherwise under any patent or patent rights of Toshiba Matsushita Display technology or others.

*The information contained herein may be changed without prior notice. It is therefore advisable to contact Toshiba Matsushita Display technology before proceeding with the design of equipment incorporating this product.

DIMENSIONAL OUTLINE

TENTATIVE

Unit : mm

Standard tolerance : ±0.5

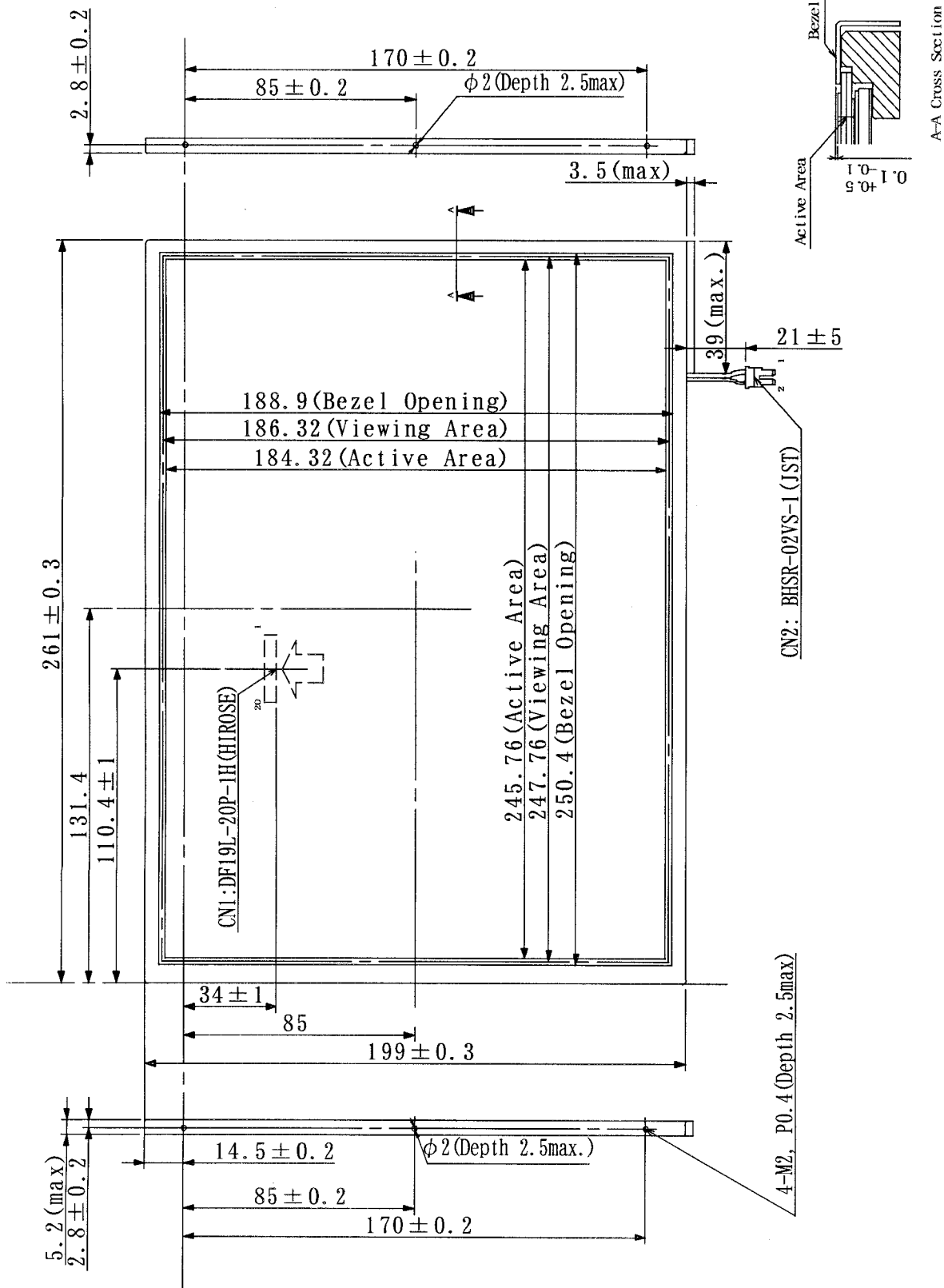

BLOCK DIAGRAM

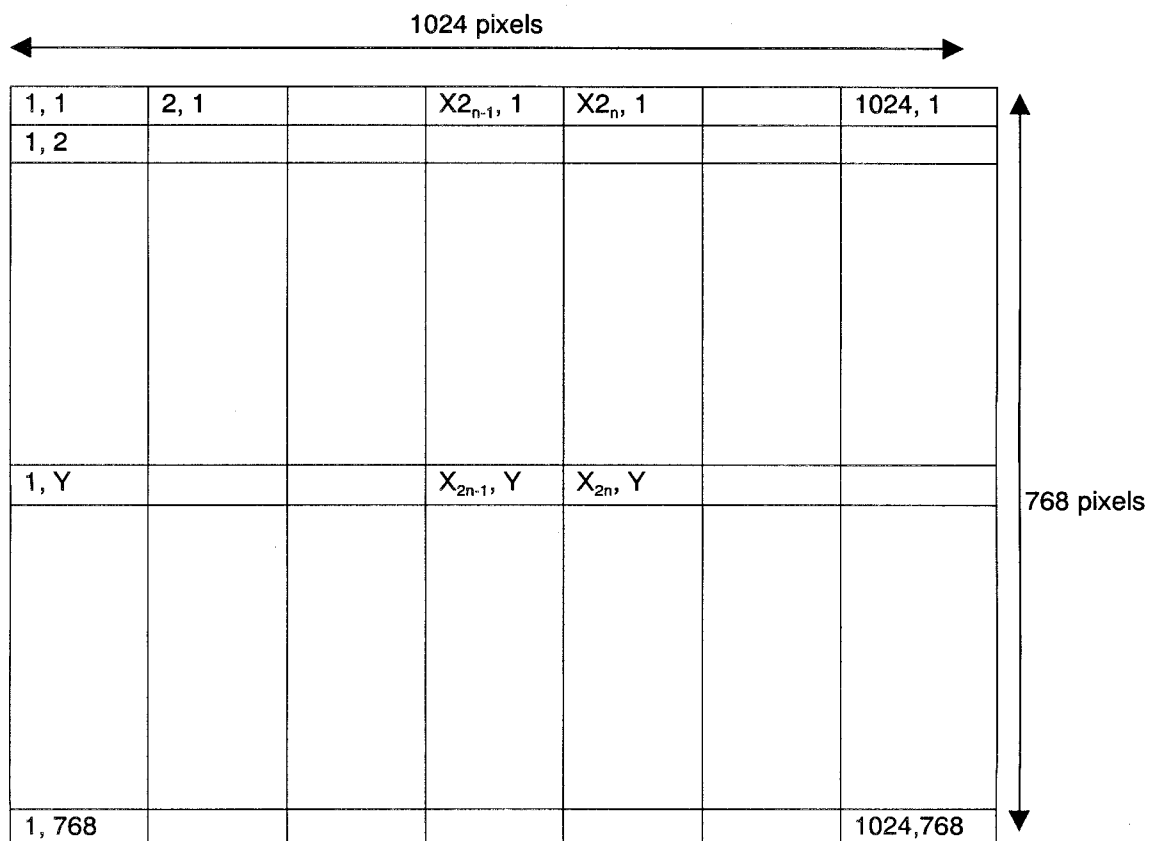
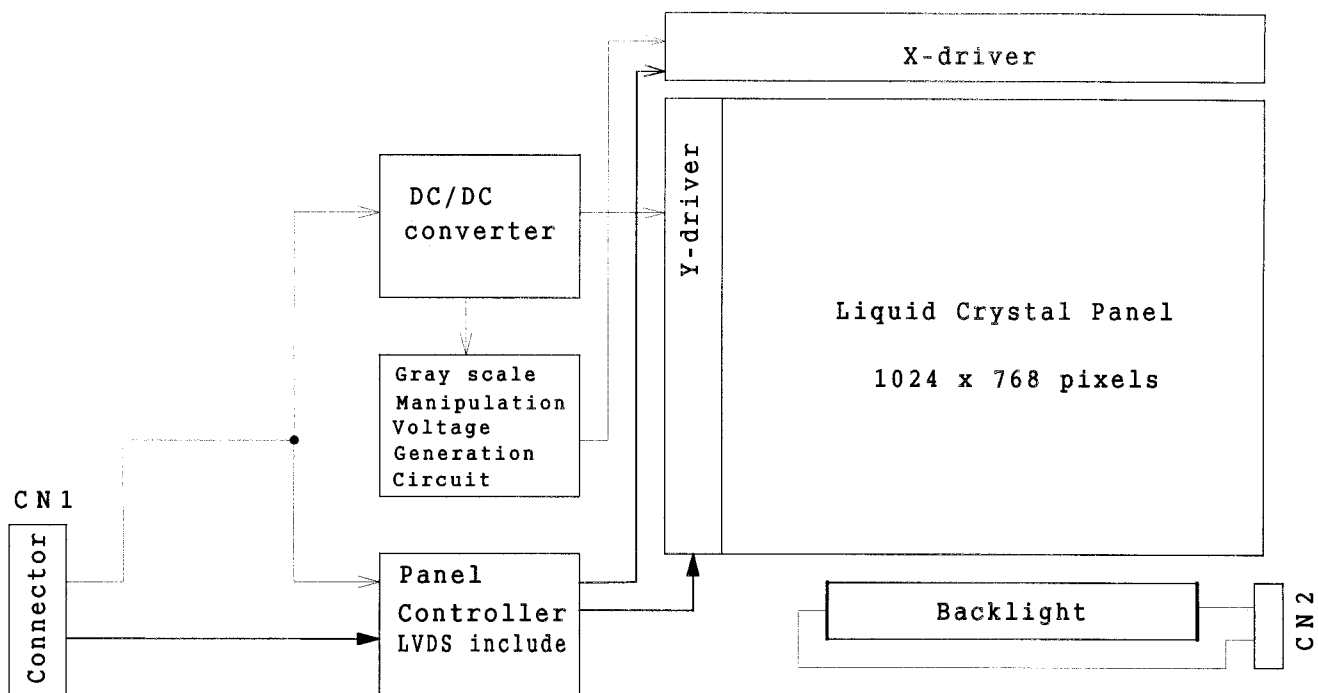

TIMING CHART

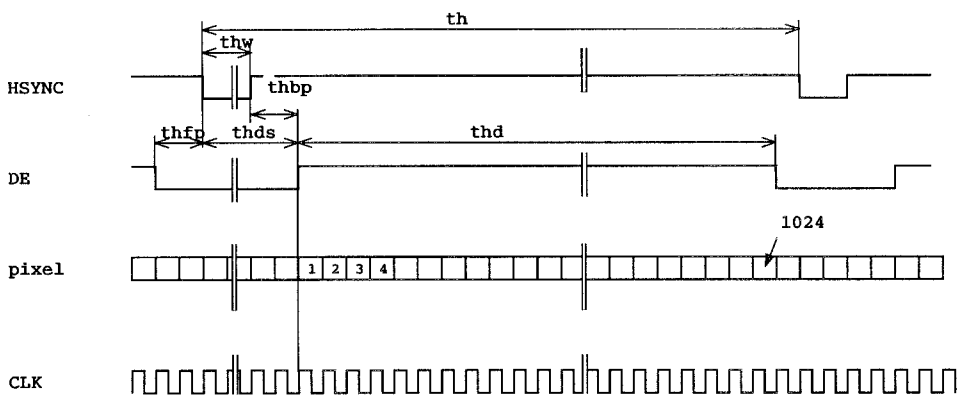
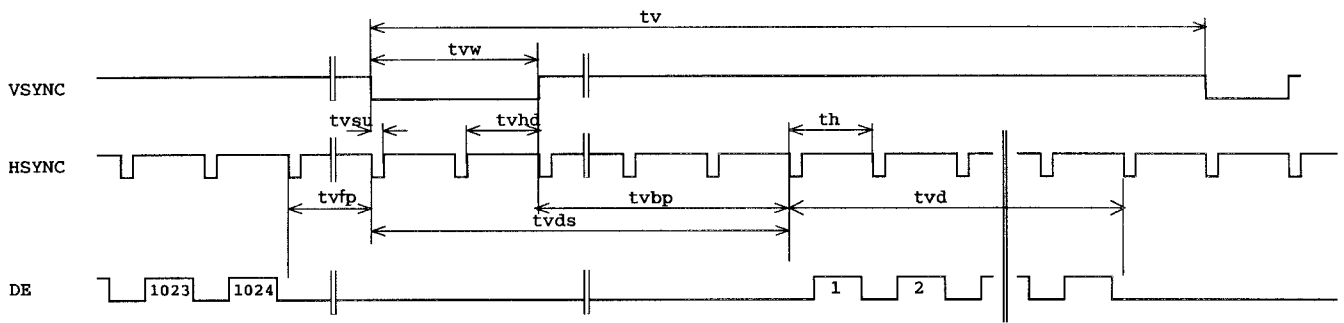

TIMING SPECIFICATION ^{1) 2) 3) 4) 5) 6) 7)}

Item	Symbol	min.	typ.	max.	unit
Horizontal Scanning Term	t_h	$1334 \times t_c$	$1344 \times t_c$	-	clock
H-sync Pulse Width	t_{hw}	$4 \times t_c$	$136 \times t_c$	-	clock
Horizontal Front Porch	t_{hfp}	$4 \times t_c$	$24 \times t_c$	-	clock
Horizontal Back Porch	t_{hbp}	$24 \times t_c$	$160 \times t_c$	-	clock
Horizontal Data Sync Period	t_{hds}	$32 \times t_c$	$296 \times t_c$	-	clock
Horizontal Display Term	t_{hd}	$1024 \times t_c$	$1024 \times t_c$	$1024 \times t_c$	clock
Frame Period	t_v	$778 \times t_h$	$806 \times t_h$	$860 \times t_h$	line
V-sync Pulse Width	t_{vw}	$2 \times t_h$	$6 \times t_h$	-	line
V-sync Set Up Time (to H-sync)	t_{vsu}	$8 \times t_c$	-	-	clock
V-sync Hold Time	t_{vhd}	$8 \times t_c$	-	-	clock
Vertical Front Porch	t_{vfp}	$1 \times t_h$	$3 \times t_h$	-	line
Vertical Back Porch	t_{vbp}	$2 \times t_h$	$29 \times t_h$	-	line
Vertical Data Sync Period	t_{vds}	$8 \times t_h$	$35 \times t_h$	-	line
Vertical Display Term	t_{vd}	$768 \times t_h$	$768 \times t_h$	$768 \times t_h$	line
Clock Period	t_c	15.0	15.38	-	ns

Note 1) Refer to "Timing Chart" and LVDS (THC63LVDF84A-85) specifications by THine Electronics, Inc. corporation.

Note 2) If DE is fixed to "H" or "L" level for certain period while NCLK is supplied, the panel displays black with some flicker.

Note 3) If NCLK is fixed to "H" or "L" level for certain period while DE is supplied, the panel may be damaged.

Note 4) Please adjust LCD operating signal timing and FL driving frequency, to optimize the display quality.

There is a possibility that flicker is observed by the interference of LCD operating signal timing and FL driving condition (especially driving frequency), even if the condition satisfies above timing specifications and recommended operating conditions shown in 3.

Note5) Do not make t_v , t_{vhd} and t_{vds} fluctuate.

If t_v , t_{vhd} , and t_{vds} are fluctuate, the panel displays black.

Note6) In case of using the long frame period, the deterioration of display quality, noise etc. may be occurred.

Note7) NCLK count of each Horizontal Scanning Time should be always the same.

V-Blanking period should be " n " X "Horizontal Scanning Time". (n : integer)

Frame period should be always the same.

CONNECTOR PIN ASSIGNMENT FOR INTERFACE

CN1 INPUT SIGNAL

Connector : DF19L-20P-1H / HIROSE

Mating Connector : DF19G-20S-1F (FPC), DF19G-20S-1C (Cable)

Terminal No.	Symbol	Function
1	V _{DD}	Power Supply : +3.3V
2	V _{DD}	Power Supply : +3.3V
3	V _{SS}	GND
4	V _{SS}	GND
5	RxIN0-	Negative LVDS differential data input (R0-R5,G0)
6	RxIN0+	Positive LVDS differential data input (R0-R5,G0)
7	V _{SS}	GND
8	RxIN1-	Negative LVDS differential data input (G1-G5, B0-B1)
9	RxIN1+	Positive LVDS differential data input (G1-G5, B0-B1)
10	V _{SS}	GND
11	RxIN2-	Negative LVDS differential data input (B2-B5, HS, VS, DE)
12	RxIN2+	Positive LVDS differential data input (B2-B5, HS, VS, DE)
13	V _{SS}	GND
14	CLK-	Clock Signal(-)
15	CLK+	Clock Signal(+)
16	V _{SS}	GND
17	NC	
18	NC	
19	V _{SS}	GND
20	V _{SS}	GND

Note 1) Please connect GND pin to ground. Don't use it as no-connect nor connection with high impedance.

CN2 CCFL POWER SOURCE

Connector : BHSR-02VS-1 / JAPAN SOLDERLESS TERMINAL MFG CO., LTD.

Mating Connector : SM02B-BHS-1 / JAPAN SOLDERLESS TERMINAL MFG CO., LTD.

Terminal No.	Symbol	Function
1	V _{FLH}	CCFL Power Supply (high voltage)
2	V _{FLL}	CCFL Power Supply (low voltage)

**RECOMMENDED TRANSMITTER (THC63LVDF63A,THC63LVDM63A,THC63LVDM63A-85) TO LTD121EA41
INTERFACE ASSIGNMENT**
Case1: 6bit Transmitter

THC63LVDF63A,THC63LVDM63A,THC63LVDM63A-85				LTD121EA41 Interface (CN1)		
Input Terminal No.		Input Signal (Graphics controller output signal)		Output Signal Symbol	Terminal	Symbol
Symbol	Terminal	Symbol	Function			
TIN0	44	R0	Red Pixels Display Data (LSB)	TOUT0- TOUT0+	No.5 No.6	IN0- IN0+
TIN1	45	R1	Red Pixels Display Data			
TIN2	47	R2	Red Pixels Display Data			
TIN3	48	R3	Red Pixels Display Data			
TIN4	1	R4	Red Pixels Display Data			
TIN5	3	R5	Red Pixels Display Data (MSB)	TOUT1- TOUT1+	No.8 No.9	IN1- IN1+
TIN6	4	G0	Green Pixels Display Data (LSB)			
TIN7	6	G1	Green Pixels Display Data			
TIN8	7	G2	Green Pixels Display Data			
TIN9	9	G3	Green Pixels Display Data			
TIN10	10	G4	Green Pixels Display Data	TOUT2- TOUT2+	No.11 No.12	IN2- IN2+
TIN11	12	G5	Green Pixels Display Data (MSB)			
TIN12	13	B0	Blue Pixels Display Data (LSB)			
TIN13	15	B1	Blue Pixels Display Data			
TIN14	16	B2	Blue Pixels Display Data			
TIN15	18	B3	Blue Pixels Display Data	TCLK OUT- TCLK OUT+	No.14 No.15	CLK- CLK+
TIN16	19	B4	Blue Pixels Display Data			
TIN17	20	B5	Blue Pixels Display Data (MSB)			
TIN18	22	HSYNC	H-Sync			
TIN19	23	VSYNC	V-Sync			
TIN20	25	DE	Compound Synchronization Signal			
CLK IN	26	CLK	Data Sampling Clock			

Note 1) Please connect NC pin to nothing. Don't connect it to ground nor to other signal input.

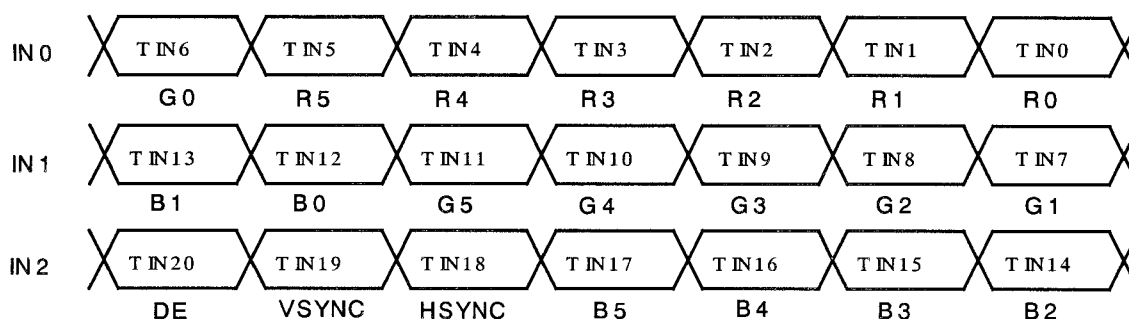

**RECOMMENDED TRANSMITTER (THC63LVDF63A,THC63LVDM63A,THC63LVDM63A-85) TO LTD121EA41
INTERFACE ASSIGNMENT**
Case2: 8bit Transmitter

THC63LVDF63A,THC63LVDM63A,THC63LVDM63A-85				LTD121EA41 Interface (CN1)		
Input Terminal No.		Input Signal (Graphics controller output signal)		Output Signal Symbol	Terminal	
Symbol	Terminal	Symbol	Function		Terminal	Symbol
TIN0	51	R0	Red Pixels Display Data (LSB)	TOUT0- TOUT0+	No.5 No.6	IN0- IN0+
TIN1	52	R1	Red Pixels Display Data			
TIN2	54	R2	Red Pixels Display Data			
TIN3	55	R3	Red Pixels Display Data			
TIN4	56	R4	Red Pixels Display Data			
TIN6	3	R5	Red Pixels Display Data (MSB)	TOUT1- TOUT1+	No.8 No.9	IN1- IN1+
TIN7	4	G0	Green Pixels Display Data(LSB)			
TIN8	6	G1	Green Pixels Display Data			
TIN9	7	G2	Green Pixels Display Data			
TIN12	11	G3	Green Pixels Display Data			
TIN13	12	G4	Green Pixels Display Data	TOUT2- TOUT2+	No.11 No.12	IN2- IN2+
TIN14	14	G5	Green Pixels Display Data(MSB)			
TIN15	15	B0	Blue Pixels Display Data (LSB)			
TIN18	19	B1	Blue Pixels Display Data			
TIN19	20	B2	Blue Pixels Display Data			
TIN20	22	B3	Blue Pixels Display Data	TOUT3- TOUT3+		
TIN21	23	B4	Blue Pixels Display Data			
TIN22	24	B5	Blue Pixels Display Data (MSB)			
TIN24	27	HSYNC	H-Sync			
TIN25	28	VSYNC	V-Sync			
TIN26	30	DE	Compound Synchronization Signal	TCLK OUT- TCLK OUT+	No.14 No.15	CLK- CLK+
TIN27	50	NC	Non Connection (open)			
TIN5	2	NC	Non Connection (open)			
TIN10	8	NC	Non Connection (open)			
TIN11	10	NC	Non Connection (open)			
TIN16	16	NC	Non Connection (open)			
TIN17	18	NC	Non Connection (open)			
TIN23	25	NC	Non Connection (open)			
CLK IN	31	CLK	Data Sampling Clock			

Note 1) Please connect NC pin to nothing. Don't connect it to ground nor to other signal input.

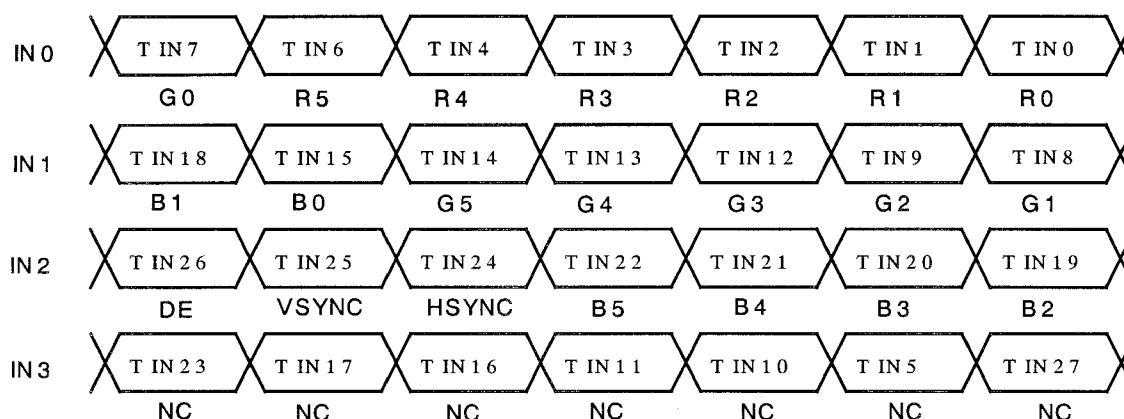

256k (k=1024) COLORS COMBINATION TABLE

	Display	R5 R4 R3 R2 R1 R0	G5 G4 G3 G2 G1 G0	B5 B4 B3 B2 B1 B0	Gray Scale Level
Basic Color	Black	L L L L L L L	L L L L L L L	L L L L L L L	-
	Blue	L L L L L L L	L L L L L L L	H H H H H H H	-
	Green	L L L L L L L	H H H H H H H	L L L L L L L	-
	Light Blue	L L L L L L L	H H H H H H H	H H H H H H H	-
	Red	H H H H H H H	L L L L L L L	L L L L L L L	-
	Purple	H H H H H H H	L L L L L L L	H H H H H H H	-
	Yellow	H H H H H H H	H H H H H H H	L L L L L L L	-
	White	H H H H H H H	H H H H H H H	H H H H H H H	-
Gray Scale of Red	Black	L L L L L L L	L L L L L L L	L L L L L L L	L 0
	Dark ↑ ↓ Light	L L L L L L H	L L L L L L L	L L L L L L L	L 1
		L L L L L H L	L L L L L L L	L L L L L L L	L 2
		∴	∴	∴	L3... L60
	Light	H H H H L H	L L L L L L L	L L L L L L L	L61
		H H H H H L	L L L L L L L	L L L L L L L	L62
		H H H H H H	L L L L L L L	L L L L L L L	Red L63
	Gray Scale of Green	Black	L L L L L L L	L L L L L L L	L L L L L L L
Dark ↑ ↓ Light		L L L L L L H	L L L L L L H	L L L L L L L	L 1
		L L L L L L L	L L L L L H L	L L L L L L L	L 2
		∴	∴	∴	L3... L60
Light		L L L L L L L	H H H H L H	L L L L L L L	L61
		L L L L L L L	H H H H H L	L L L L L L L	L62
		L L L L L L L	H H H H H H	L L L L L L L	Green L63
Gray Scale of Blue		Black	L L L L L L L	L L L L L L L	L L L L L L L
	Dark ↑ ↓ Light	L L L L L L L	L L L L L L L	L L L L L L H	L 1
		L L L L L L L	L L L L L L L	L L L L L H L	L 2
		∴	∴	∴	L3... L60
	Light	L L L L L L L	L L L L L L L	H H H H L H	L61
		L L L L L L L	L L L L L L L	H H H H H L	L62
		L L L L L L L	L L L L L L L	H H H H H H	Blue L63
	Gray Scale of White & Black	Black	L L L L L L L	L L L L L L L	L L L L L L L
Dark ↑ ↓ Light		L L L L L L H	L L L L L L H	L L L L L L H	L 1
		L L L L L H L	L L L L L H L	L L L L H L	L 2
		∴	∴	∴	L3... L60
Light		H H H H L H	H H H H L H	H H H H L H	L61
		H H H H H L	H H H H H L	H H H H H L	L62
		H H H H H H	H H H H H H	H H H H H H	white L63

**FOR SAFETY**

LCD module is generally designed with precise parts to achieve light weighted thin mechanical dimensions. In using our Modules, make certain that you fully understand and put into practice the warnings and safety precautions detailed in Engineering Information No.EE-N001, "CAUTIONS AND INSTRUCTIONS FOR TOSHIBA MATSUSHITA DISPLAY TECHNOLOGY LCD MODULES". Refer to individual specifications and TECHNICAL DATA sheets (hereinafter called "TD") for more detailed technical information.

1) SPECIAL PURPOSES

A) Toshiba Matsushita Display technology's Standard LCD Modules have not been customized for operation in extreme environments or for use in applications where performance failures could be life-threatening or otherwise catastrophic.

B) Since Toshiba Matsushita Display technology's Standard LCD Modules have not been designed for operation in extreme environments, they must never be used in devices that will be exposed to abnormally high levels of vibration or shock which exceed Toshiba Matsushita Display technology's published specification limits.

C) In addition, since Toshiba Matsushita Display technology Standard LCD Modules have not been designed for use in applications where performance failures could be life-threatening or catastrophic, they must never be installed in aircraft navigation control systems (such as, but not limited to Traffic Collision Avoidance System and Air Traffic Indicator), in military defense or weapons systems, in critical industrial process-control systems (e.g., those involved in the production of nuclear energy), or in critical medical device or patient life-support systems.

2) DISASSEMBLING OR MODIFICATION

DO NOT DISASSEMBLE OR MODIFY the module. It may damage sensitive parts inside LCD module, and may cause scratches or dust on the display.

Toshiba Matsushita Display technology does not warrant the module, if customer disassembled or modified it.

3) BREAKAGE OF LCD PANEL

DO NOT INGEST liquid crystal material, DO NOT INHALE this material, and DO NOT CONTACT the material with skin, if LCD panel is broken and liquid crystal material spills out.

If liquid crystal material comes into mouth or eyes, rinse mouth or eyes out with water immediately.

If this material contact with skin or cloths, wash it off immediately with alcohol and rinse thoroughly with water.

4) GLASS OF LCD PANEL

BE CAREFUL WITH CHIPS OF GLASS that may cause injuring fingers or skin, when the glass is broken.

5) ELECTRIC SHOCK

DISCONNECT POWER SUPPLY before handling LCD module.

DO NOT TOUCH the parts inside LCD module and the fluorescent lamp's connector or cables in order to prevent electric shock, because high voltage is supplied to these parts from the inverter unit while power supply is turned on.

6) ABSOLUTE MAXIMUM RATINGS AND POWER PROTECTION CIRCUIT

DO NOT EXCEED the absolute maximum rating values under the worst probable conditions caused by the supply voltage variation, input voltage variation, variation in parts' constants, environmental temperature, etc., otherwise LCD module may be damaged.

Employ protection circuit for power supply, whenever the specification or TD specifies it.

Suitable protection circuit should be applied for each system design.

7) DISPOSAL

When dispose LCD module, obey to the applicable environmental regulations.