



To: Wistron

This specification is only used for discussing the included items.
You haven't to approve this specification.
When we shall agree the specification, we will issue the formal one.

SPECIFICATION(TENTATIVE)

FOR

TOSHIBA TFT-LCD MODULE

LTD154EX0V

NR-LTD154EX0V-01

DATE OF ISSUE: 2004-02-25

TV/PC/Monitor-Use Marketing & Engineering Dept.
AVC-USE LCD Div.

Toshiba Matsushita Display Technology Co.,Ltd
1-9-2, Hatara-cho, Fukaya-shi, Saitama, 366-8510, JAPAN

Revision History

Date	Rev.	Sheet (New)	Item	Old	New	Reason

Caution and Handling Precaution

For your end user's safety, it is strongly advised that the items with "*" should be included in the instruction manual of the system which may be issued by your organization.

For Safety



Warning

- (1) Toshiba Matsushita Display Technology's Standard LCD modules have not been customized for operation in extreme environments or for use in applications where performance failures could be life-threatening or otherwise catastrophic. Since they must never be installed in aircraft navigation control systems (such as, but not limited to Traffic Collision System and Air traffic Indicator), in military defense or weapons systems, in critical industrial process-control systems (e.g., those involved in the production of nuclear energy), or in critical medical device or patient life-support systems.
- (2) DISCONNECT POWER SUPPLY before handling LCD module.
DO NOT TOUCH the parts inside LCD module and the fluorescent lamp's (hereinafter called "FL") connector or cable in order to prevent electric shock, because high voltage is supplied to these parts from the inverter unit while power supply is turned on.
- (3) Make sure to insert the module FL connector to the inverter connector in correct position.
Do not insert in irregular position.
If incorrect, this may cause smoke or burn of electrical parts by high voltage of FL circuit.
If there is a possibility that the connector has been inserted incorrectly, please re-insert the connector only after you confirm the module and FL power is completely off. When disconnecting connector, do not pull on the cable.
DO NOT USE the mating FL connector which Toshiba Matsushita Display Technology does not specify.
Otherwise, Toshiba Matsushita Display Technology shall not be liable for any damages caused by the connector.



Caution

- (1) DO NOT DISASSEMBLE OR MODIFY the module.
Sensitive parts inside LCD module may be damaged, and dusts or scratches may mar the displays.
Toshiba Matsushita Display Technology does not warrant the modules, if customer disassembled or modified them.
- * (2) DO NOT INGEST liquid crystal material, DO NOT INHALE this material, and DO NOT PERMIT this material to contact the skin, if glass of LCD panel is broken.
If liquid crystal material contacts the skin, mouth or clothing, take the following actions immediately.
In case contact to the eye or mouth, rinse with large amount of running water for more than 15 minutes. In case contact to the skin or clothing, wipe it off immediately and wash with soap and large amount of running water for more than 15 minutes. The skin or clothing may be damaged if liquid crystal material is left adhered.
In case ingestion, rinse out the mouth well with water. After spewing up by drinking large amount of water, get medical treatment.
- * (3) BE CAREFUL WITH CHIPS OF GLASS that may cause injuring fingers or skin, when the glass is broken.
Since FL is also made of glass, when FL is built in, handle it with due caution as well.
- (4) Be careful with handling the metal frame (bezel) of a module. Even though burr disposal treatment is performed, it may cause injuring. Be careful with edges of glass parts and touch panel identically. For designing the system, give special consideration that the wiring and parts do not touch those edges.
- (5) DO NOT EXCEED the absolute maximum rating values under the worst probable conditions caused by the supply voltage variation, input voltage variation, variation in parts' constants, ambient temperature, etc., otherwise LCD module may be damaged.

- (6) Don't exceed "the recommended operation conditions" in this specification. (The LCD panel should be used within "the recommended operation conditions".)

The performance and quality of the LCD panel are warranted only when the LCD panel is used within "the recommended operation conditions". Toshiba Matsushita Display Technology never warrants the performance and quality of the LCD panel when you use the LCD panel over "the recommended operation conditions", although within "the absolute maximum rating".

To use the LCD panel over "the recommended operation conditions" may have bad influence on the characteristics and reliability of the LCD panel and may shorten the life of the LCD panel.

Therefore, when designing the whole set, not to be over "the recommended operation conditions", you should fully take care of supply voltage change, characteristic of connection parts, surge of input-and-output line, and surrounding temperature.

- (7) Suitable protection circuit should be applied for each system design.
DO NOT MODIFY the fuse used in the module. It may cause overheat and/or burning if dusts or metal particles are on the PCBs in the LCD module.
- (8) Be sure that power supply output from the system should be limited to smaller values than listed shown below. (For example Quick Arcing Fuse with listed ratings can be used.)

It is because this LCD module explained in this specification has a current limiter, with such function at power input line(s). But it may be some possibility of overheat and/or burning of LCD module and its peripheral devices before current limiter of the module when open-short test of the module is performed by using power supply higher than following recommended value.

Power supply	Recommended maximum output current of power supply	Recommended Fuse Rating (in case of using fuse for current limiter)	Built-in Fuse Rating (for reference)
V _{DD}	4.0 A	0.5-3.0 A	1.25 A

- (9) Always comply with all applicable environmental regulations, when disposing of LCD.
- (10) When FL becomes extremely dark and its color changes from white to pink, stop the use of the module immediately. FL, at the end of its life with its discharge color turns into pink as the characteristics of FL, may adversely affect the module at the end part of FL due to temperature raising caused by depletion of the mercury which is contained in FL tube, or may have a possibility of breakage.

For Designing the System

- (1) Toshiba Matsushita Display Technology always endeavor to maintain sufficient quality of the LCD panel in process of designing and manufacturing, however, to avoid causing extended damages such as accidents resulting in injury or death, fire accidents, or social damages if the LCD panel fails, please adopt safe design as a whole set, by adopting redundant design, taking measure in set design to prevent fire-spreading, over-current, or incorrect operation, etc.
- (2) LCD module should be assembled to the system by using all mounting holes specified in this specification and with the specified screws. In addition, some modules may not be necessary to use all the mounting holes. Make comprehensive judgments on the entire system.

- (3) Power supply lines should be designed as follows.
 Power supplies should always be turned on before the input signals are supplied to LCD module, and the input signals should be disconnected before power supplies are turned off.
 If the sequence does not satisfy specified conditions, it may cause miss-operation of the panel.
 Refer to "2.4.2 Sequence of Power Supplies and Signals" for the detailed specification.
 In addition, refer to individual specifications for unused terminals.
- (4) DO NOT GIVE high voltage to "Low Voltage" side of the FL.
 For example, DO NOT USE a floating inverter which gives high voltage to "Low Voltage" side. it may cause insufficient brightness or unstable operation of FL, and smoke or burn of the parts.
- (5) Make sure to connect correctly high-voltage wire and low-voltage wire between FL tube and inverter unit.
- (6) Input FL starting voltage(V_{SFL}) should not be less than two second.
 If it were less than two second, it may cause unstable operation of FL.
 Inverter should be design to stop output when the inverter is no-load to FL tubes (due to breakage of FL, etc.) to prevent high-voltage generation.
 When high voltage is applied to FL continuously without normal operation of FL (due to output leakage within FL wiring circuit, etc.) it may cause smoke or burn. To prevent excess current, design the inverter with a protection circuit such as a current limiter (excess current detection) to stop inverter output.
 Please adjust inverter circuit parameters, such as capacitor, resistor, to assure the display quality is maintained.
 There is a possibility that flicker is observed by the interference of LCD operating signal timing and FL driving condition (especially driving frequency).
- (7) In case of severe environmental condition like outdoor usage, a proper transparent protective cover(lens) over LCD module is recommended to apply in order to prevent scratches, and invasion of dust, water, etc., from the system's window onto LCD module.
 Ultra-violet ray cut filter is recommended to apply onto LCD module for outdoor operation. Strong ultra-violet ray may cause damage the panel. However, in that case, transmittance-luminance will decrease. Careful selection of material is required.
- (8) Design the system not to display same pattern for a long time in order to prevent image sticking on the panel. Note that incorrect sequence of power supplies and input signals may cause the sticking on the panel, too.
- (9) Some plastic materials and shock absorbing materials (rubber) used in the system may generate gases that may cause the deterioration of the polarizer laminated on LCD's panel or internal parts of the module. Prior confirmation is required.
- (10) Some materials used for packaging (for which sulfuric acid is used in the recycling process) generate gases that may cause the deterioration of the polarizer laminated on LCD's panel or internal parts of the module. Prior confirmation is required.

For Installation in Assembly

- (1) The C-MOS LSIs used in LCD module are very sensitive to ESD (Electro-static Discharge).
 Ambient humidity of working area is recommended to be higher than 50%(RH).
 Person handling LCD modules should be grounded with wrist band. Tools like soldering iron and screw driver, and working benches should be grounded.
 The grounding should be done through a resistor of 0.5-1M Ω in order to prevent spark of ESD.
- (2) When remove protection film from LCD panel, peer off the film slowly (more than three seconds) from the edge of the panel, using a soft-pointed tweezers covered by Teflon or adherent tape.

- (3) Reduce dust level in working area. Especially the level of metal particle should be decreased.
Use finger stalls or soft and dust-free gloves in order to keep clean appearance of LCD module when handled for incoming inspection and assembly.
- * (4) When LCD panel becomes dirty, wipe off the panel surface softly with absorbent cotton or another soft cloth.
If necessary, breathe upon the panel surface and then wipe off immediately and softly again.
If the dirt can not be wiped off, absorbent cotton wetted a little with normal-hexane or petroleum benzine can be used for wiping the panel.
Be careful not to spill this solvent into the inside of LCD module. Driver ICs and PCB area used inside LCD module may be damaged by the solvent.
- * (5) **AVOID THE CONDENSATION OF WATER**
Wipe off a spot or spots of water of mist and chemicals of mist on LCD panel softly with absorbent cotton or another cloth as soon as possible if happened, otherwise discoloration or stain may be caused. If water invade into LCD module, it may cause LCD module damages.
- * (6) Do not expose LCD module to the gas (which is not normally contained in the atmosphere), it may cause mis-operation or defects.
- * (7) **DO NOT APPLY MECHANICAL FORCES.**
Do not bend or twist LCD module even momentary when LCD module is installed an enclosure of the system. Bending or twisting LCD module may cause its damages.
Make sure to design the enclosure that bending/twisting forces are not applied to LCD module when it is installed in the system.
Refrain from strong mechanical shock like dropping from the working bench or knocking against hard object.
These may cause glass of the panel crack, damage of FL or other miss-operation.
- * (8) Refrain from excessive force like pushing the surface of LCD panel. This may cause damage of the panel or electrical parts on PCB.
- * (9) Do not put heavy object such as tools, books, etc., and do not pile up LCD modules.
Be careful not to touch surface of the polarizer laminated to the panel with any hard and sharp object. The polarizer is so soft that it can easily scratched, even the protect film covers it.
- (10) When inserting or disconnecting the connectors to LCD module, be sure not to apply force against PCB, nor connecting cables, otherwise internal connection of PCB and TAB drivers may be damaged.
Do not fasten screws while putting cables like those for interface or FL between LCD module and the enclosure.
Make sure to insert the module FL connector to the inverter connector in correct position.
If incorrect, this may cause smoke or burn of electrical parts by high voltage of FL circuit.
- (11) Be careful not to pull the FL cables of the backlight in order to avoid mechanical damage in FL lamp and soldering area.
Be careful not to pull or not to hurt the FPC (Flexible Printed Circuit) cables.
- (12) Power supplies should always be turned off in assembling process.
Do not connect or disconnect the power cables and connectors with power applied to LCD module. This may cause damage of module circuit.
The signal should be applied after power are turned on. And the signal should be removed before power supplies are turned off. (Refer to "For Designing The System"(2).)
- * (13) In case of LCD long period operation, discoloration of light guide or optical sheet will be happened due to ultra violet and heat from CCFL. As the result, there is possibility to have out of specification for the optical characteristic as "5.2". But this is not irregular phenomena. Moreover, CCFL also has the characteristic of color shift by long period operation.

For Transportation and Storage

- (1) Do not store LCD module in high temperature, especially in high humidity for a long time (approximately more than one month).

It is recommended to store LCD module where the temperature is in the range of 0 to 35 °C and the relative humidity is lower than 70%.

- (2) Store LCD module without exposure to direct sunlight or fluorescent lamps in order to prevent the module from strong ultra violet ray.
- * (3) Avoid condensation of water on LCD module, otherwise it may cause mis-operation or defects. Keep away LCD module from such ambient.
- (4) In case of transportation or storage after opening the original packing. LCD module are recommended to be repacked into the original packaging with the same method, especially with same kind of desiccant.

- CONTENTS -

Revision History	Sheet	1
Caution and Handling Precaution		2
1. Scope		7
2. Product Specifications		7
2.1 General Specifications		
2.2 Absolute Maximum Ratings		
2.3 Mechanical Specifications		
2.3.1 Weight		
2.3.2 Dimensional Outline		
2.4 Electrical Specifications		
2.4.1 Circuit Diagram		
2.4.2 Sequence of Power Supplies and Signals		
2.4.3 Timing Chart		
2.4.4 Timing Specifications		
2.4.5 Interface Connector		
2.4.6 Colors Combination Table		
3. Recommended Operating Conditions		18
4. Electrical Characteristics		19
4.1 Test Conditions		
4.2 Specifications		
5. Optical Characteristics		20
5.1 Test Conditions		
5.2 Optical Specifications		
6. Quality		21
6.1 Inspection AQL		
6.2 Test Conditions		
6.3 Dimensional Outline		
6.4 Appearance Test		
6.4.1 Test Conditions		
6.4.2 Specifications		
6.5 Display Quality		
6.5.1 Test Conditions		
6.5.2 Specifications		
6.6 Reliability Test		
6.6.1 Test Conditions		
6.6.2 Specifications		
6.7 Labels		
7. Lifetime		26
7.1 Module		
7.2 Lamp		
7.2.1 Test Conditions		
7.2.2 Specifications		
8. Packaging		27
8.1 Carton		
9. Warranty		28
10. Regulation		28
11. Measuring Method		28
11.1 Measuring Systems		
11.2 Measuring Methods		
12. EDID		31

1. Scope

This specification is applicable to Toshiba Matsushita Display Technology's 38cm diagonal size TFT-LCD module "LTD154EX0V" designed for Personal Computer.

2. Product Specifications

2.1 General Specifications

Item	Specifications
Display Mode	TN color(64 gray scales, 262,144 colors) Transmissive type, Normally white
Viewing Direction	6 o'clock (in direction of maximum contrast)
Driving Method	TFT active matrix
Input Signals	LVDS interface RxOCLK+, RxOCLK-, RxECLK+, RxECLK- RxOIN0+, RxOIN0-, RxEIN0+, RxEIN0-, RxOIN1+, RxOIN1-, RxEIN1+, RxEIN1- RxOIN2+, RxOIN2-, RxEIN2+, RxEIN2-
Display Area	332.16 (W) × 207.6(H) (mm)
Bezel Opening	335.0 (W) × 210.7 (H) (mm)
Number of Pixels	1280 (W) × 800 (H) ¹⁾
Pixel Pitch	0.2595 (W) × 0.2595 (H) (mm) ¹⁾
Pixel Arrangement	RGB vertical stripes ¹⁾
Surface Treatment	Anti-Reflection and hard coat 3H on LCD surface
Backlight	Single cold-cathode fluorescent lamp for sidelighting
Dimensional Outline	344.5max. (W) × 222.5max. (H) × 6.5max. (D) (mm)
EDID	SPWG Version 2.0

Note 1)

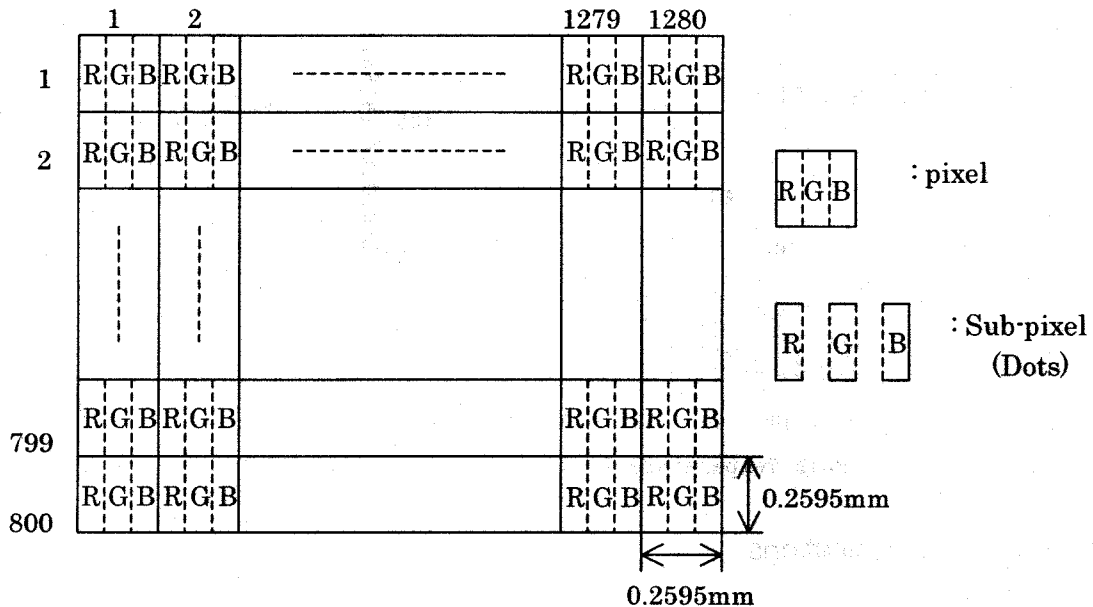

2.2 Absolute Maximum Ratings ¹⁾

Item	Symbol	Min.	Max.	Unit	Checked Terminal ⁴⁾
Supply Voltage	V_{DD}	-0.3	+4.0	V	$V_{DD} - GND$
Input Voltage of Signals	V_{IN}	-0.3	$V_{DD}+0.3$	V	LVDS interface
FL Driving Voltage	V_{FL}	-	2.0	kV(rms)	
FL Driving Frequency	f_{FL}	-	100	kHz	
Operating Ambient Temperature ²⁾	T_{OP}	0	+50	°C	
Operating Ambient Humidity ²⁾	H_{OP}	10	90	%(RH)	
Storage Temperature ²⁾	T_{STG}	-20	+60	°C	
Storage Humidity ²⁾	H_{STG}	10	90	%(RH)	
Operating Temperature for Panel ³⁾	-	0	+60	°C	

Note 1) Do not exceed the maximum rating values under the worst probable conditions taking into account the supply voltage variation, input voltage variation, variation in part constants, and ambient temperature and so on. Otherwise the module may be damaged.

2) Wet bulb temperature should be 39°C Max, and no condensation of water. See figure below.

3) The surface temperature caused by self heat radiation of cell itself is specified on this item.

4) Refer to 2.4.5

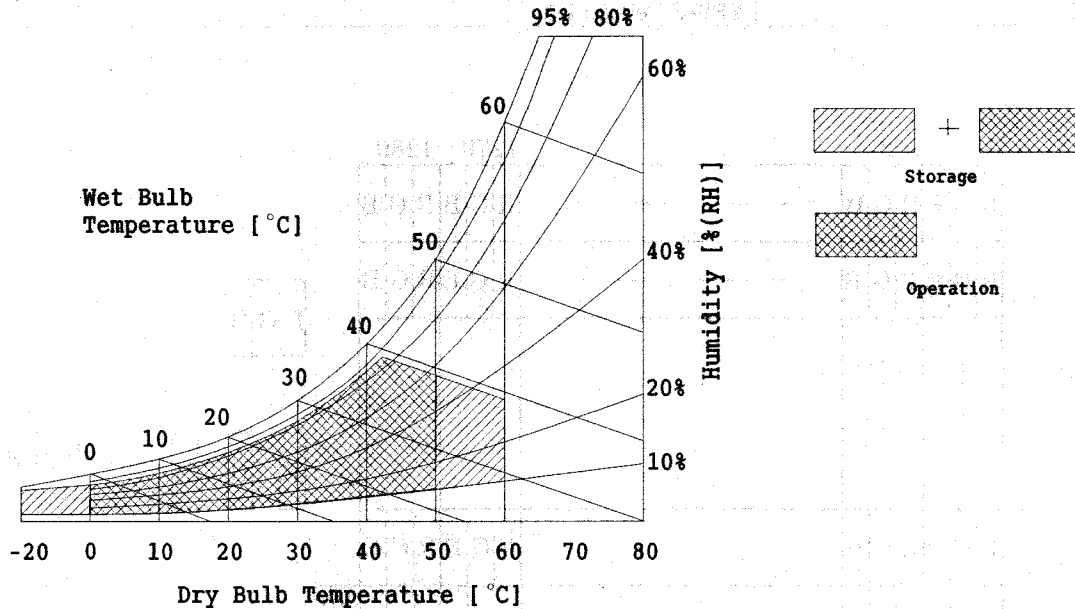

2.3 Mechanical Specifications

2.3.1 Weight

575 ± 20 (g)

2.3.2 Dimensional Outline
(front figure)

Unit : mm
Standard Tolerance: ±0.5

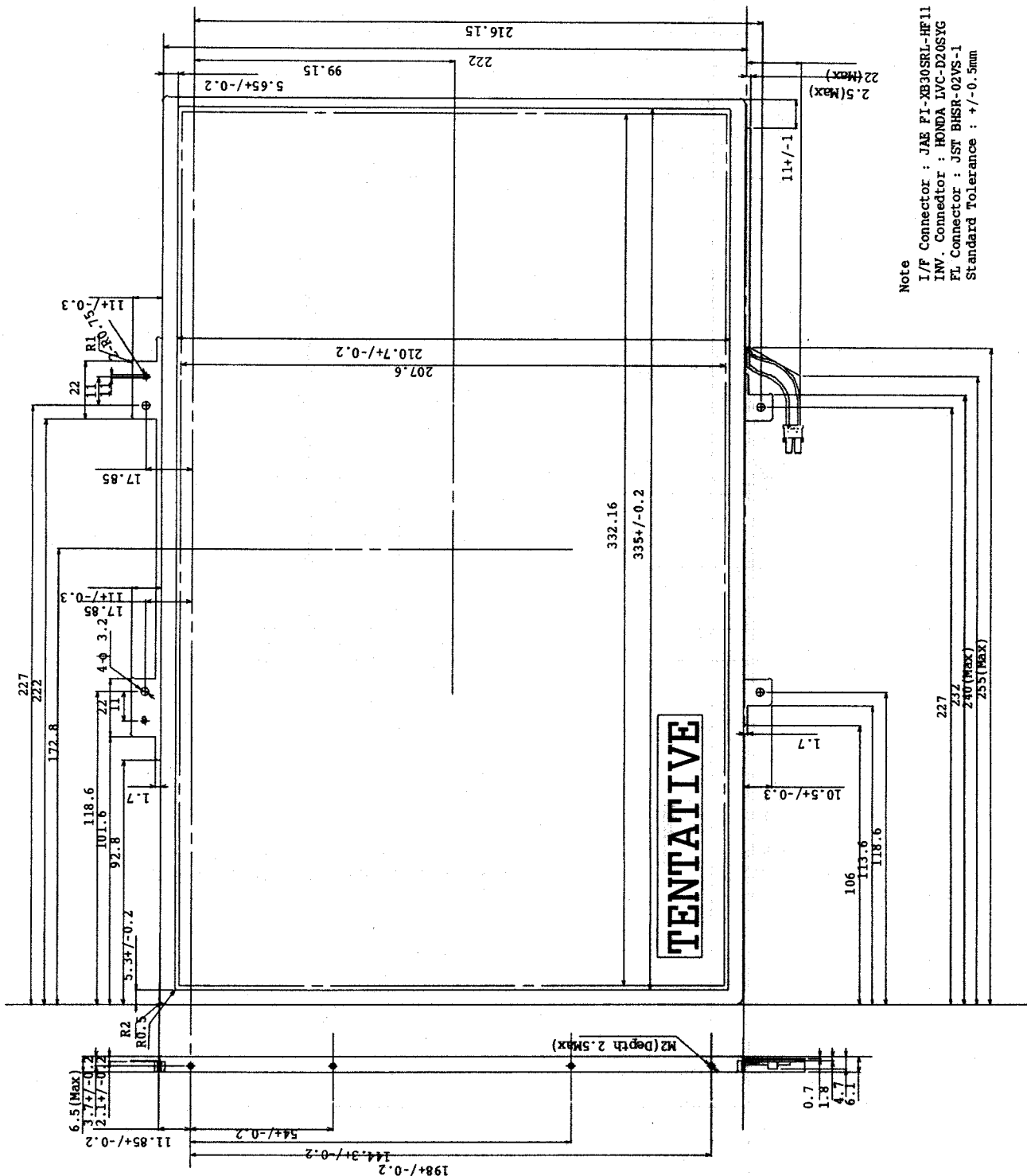

Note
I/F Connector : JAE FI-XB30SRU-HF11
INV. Connector : HONDA LVC-D205YG
FL Connector : JST BHSR-02VS-1
Standard Tolerance : +/-0.5mm

Note) If customer remove tape for fixing FL cable, Toshiba Matsushita Display Technology can not guarantee.

Unit : mm

Standard Tolerance: ±0.5

(back figure)

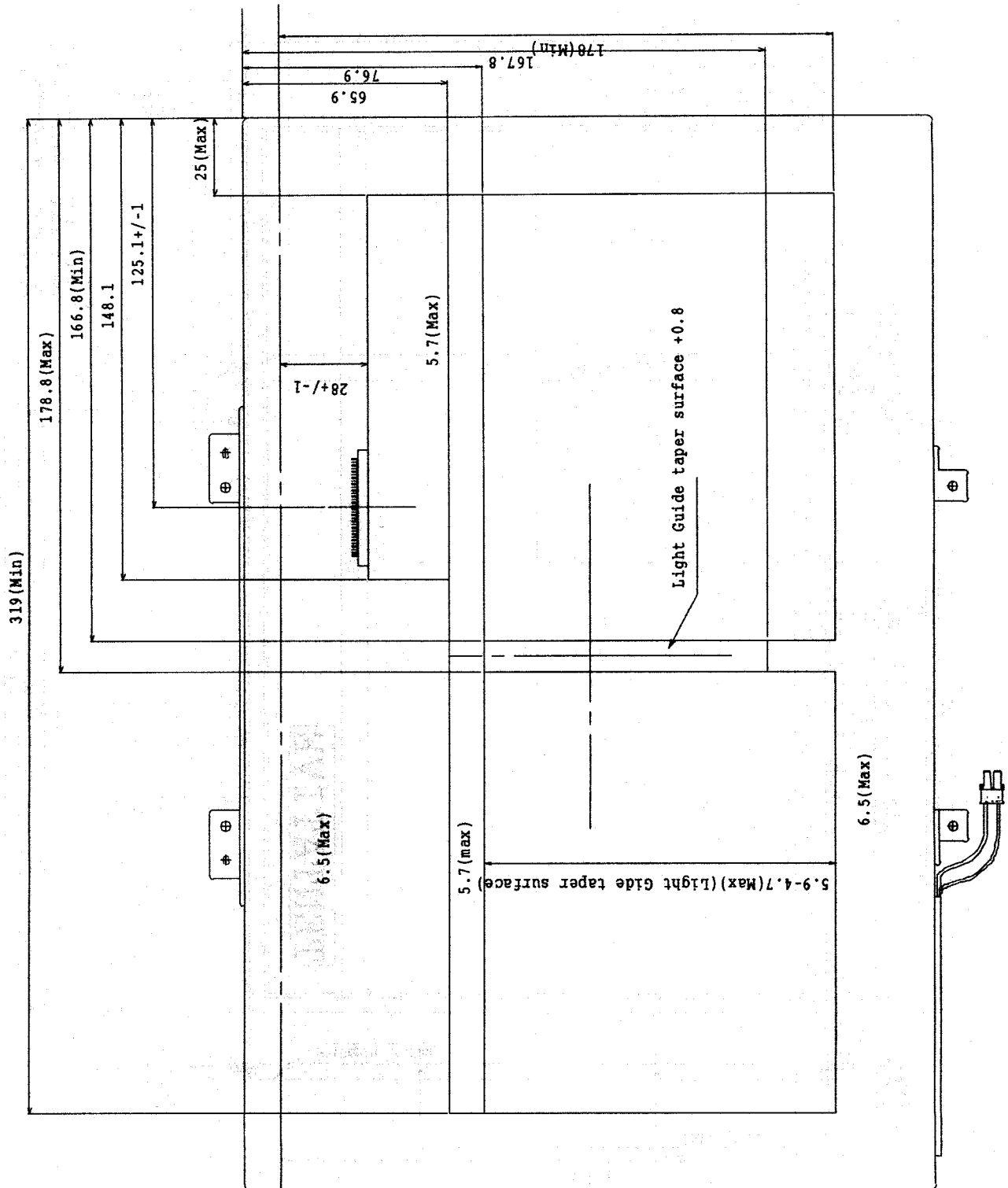

Note) Never push LCD back side. If LCD back side was pressed, It may cause damage of the back light system.

2.4 Electrical Specifications

2.4.1 Circuit Diagram

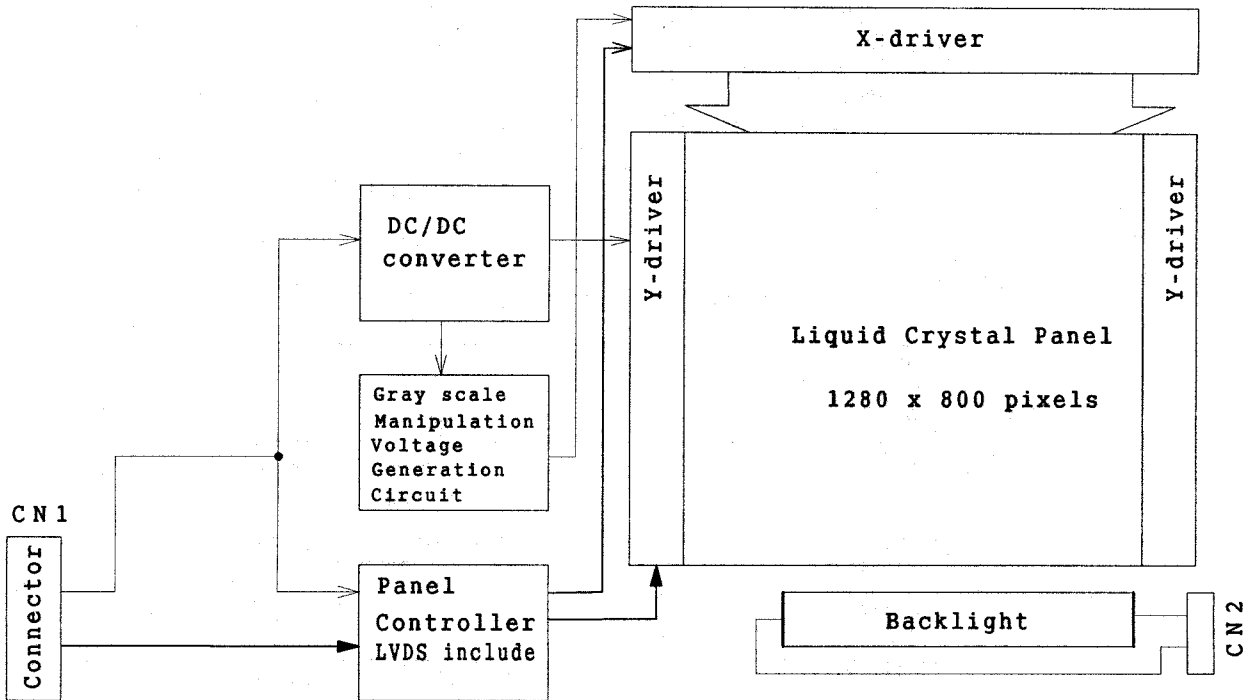

2.4.2 Sequence of Power Supplies and Signals

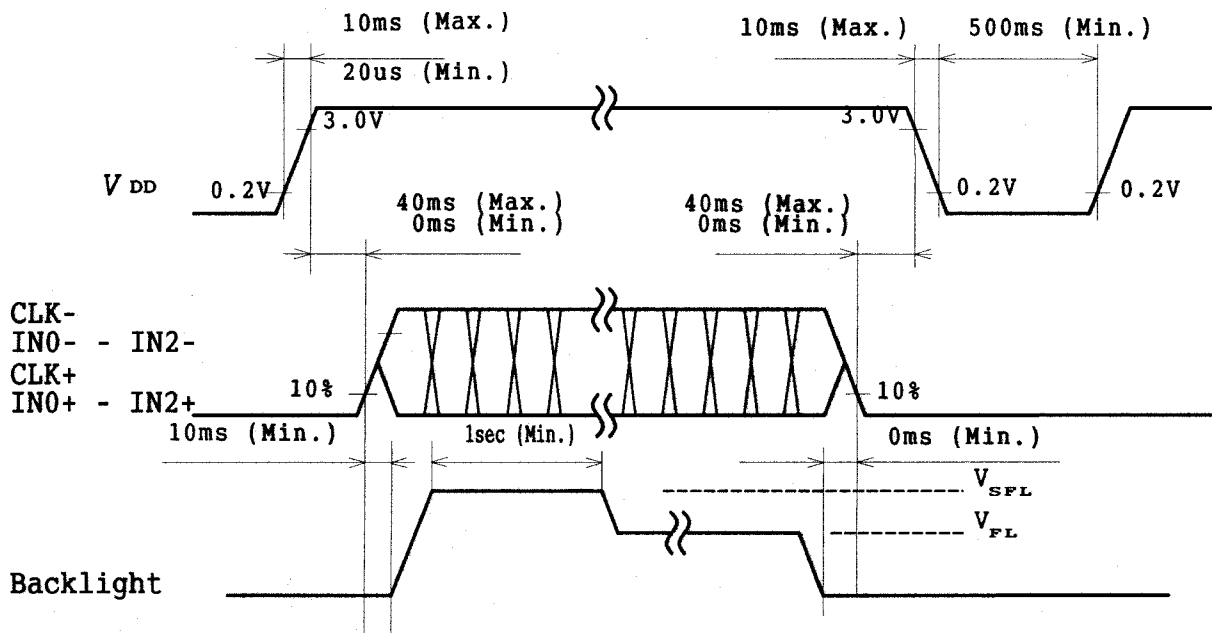

2.4.3 Timing Chart

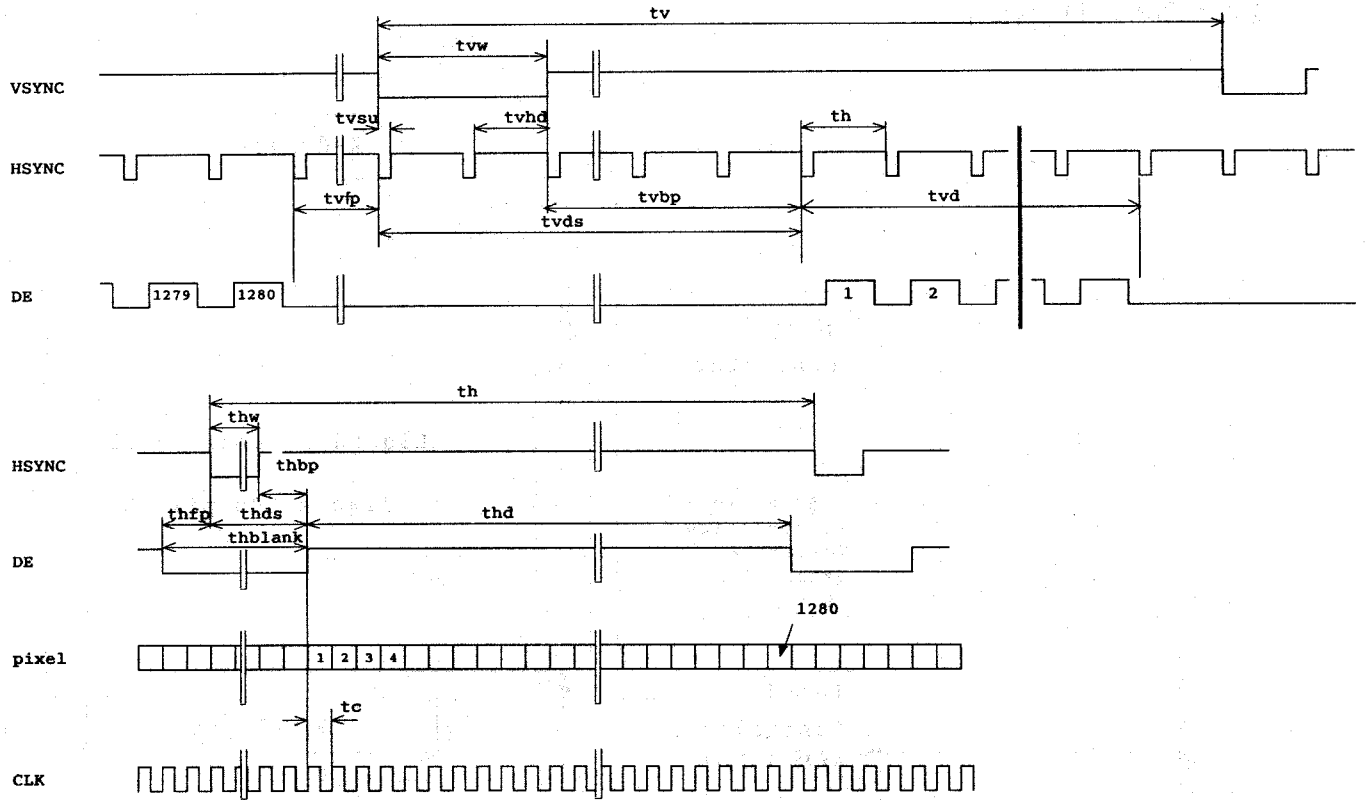

2.4.4 Timing Specifications ^{1) 2) 3) 4) 5) 6) 7)}

Item	Symbol	Min.	Typ.	Max.	Unit
Horizontal Scanning Term	Th	-	1400	-	Tc
		-	20.01	-	us
H-sync Pulse Width	HSPW	10	-	-	Tc
Horizontal Front Porch	thfp	10	-	-	Tc
Horizontal Back Porch	ta	10	-	-	Tc
Horizontal Blanking Term	HBL	-	120	-	Tc
Horizontal Display Term	HA	1280	1280	1280	Tc
Frame Period	Tvp	-	833	-	Thp
		-	16.67	-	ms
V-sync Pulse Width	VSPW	2	-	-	Thp
V-sync Set Up Time (to H-sync)	tsu	10	-	-	Tc
V-sync Hold Time	tvdh	10	-	-	Tc
Vertical Front Porch	mfp	2	-	-	Thp
Vertical Back Porch	Tvbp	6	-	-	Thp
Vertical Blanking Term	VBL	-	33	-	Thp
Vertical Display Term	VA	800	800	800	Thp
DE Pulse Width	HA	1280	1280	1280	Tc
Clock Period	Tc	-	14.29	-	ns

Note 1) Refer to "Timing Chart" and LVDS (DS90CF384) specifications by National semiconductor corporation.

Note 2) If ENAB is fixed to "H" or "L" level for certain period while NCLK is supplied, the panel displays black with some flicker.

Note 3) If NCLK is fixed to "H" or "L" level for certain period while ENAB is supplied, the panel may be damaged.

Note 4) Please adjust LCD operating signal timing and FL driving frequency, to optimize the display quality.

There is a possibility that flicker is observed by the interference of LCD operating signal timing and FL driving condition (especially driving frequency), even if the condition satisfies above timing specifications and recommended operating conditions shown in 3.

Note5) Do not make t_v , t_{vdh} and t_{vds} fluctuate.

If t_v , t_{vdh} , and t_{vds} are fluctuate, the panel displays black.

Note6) In case of using the long frame period, the deterioration of display quality, noise etc. may be occurred.

Note7) NCLK count of each Horizontal Scanning Time should be always the same.

V-Blanking period should be " n " X "Horizontal Scanning Time". (n : integer)

Frame period should be always the same.

Note 8) Please keep below equations.

$$VBL = T_{vfp} + T_{vbp}$$

$$HSPW = HBL - Thfp - ta$$

$$Thbp = HSPW + ta$$

2.4.5 Interface Connector ¹⁾

CN1 INPUT SIGNAL (FI-XB30SRL-HF11 / JAE)

[Mating Connector :Wire Type FI-X30H(Housing), FI-XC3-1-15000(Contact)

FPC Type FI-X30M or FI-X30MR, Coax Type FI-X30C or FI-X30C2(Housing), FI-X30CH-7000(Shell)]

Terminal No.	Symbol	Function
1	V _{SS}	GND
2	V _{DD}	POWER SUPPLY : +3.3V
3	V _{DD}	POWER SUPPLY : +3.3V
4	V _{EDID}	DDC 3.3V POWER SUPPLY : +3.3V
5	NC	Non-Connection
6	CLK _{EDID}	DDC Clock
7	DATA _{EDID}	DDC Data
8	RxIN0-	Negative LVDS differential data input , [R0-R5, G0]
9	RxIN0+	Positive LVDS differential data input , [R0-R5, G0]
10	V _{SS}	GND
11	RxIN1-	Negative LVDS differential data input , [G1-G5, B0-B1]
12	RxIN1+	Positive LVDS differential data input , [G1-G5, B0-B1]
13	V _{SS}	GND
14	RxIN2-	Negative LVDS differential data input , [B2-B5, HS, VS, DE]
15	RxIN2+	Positive LVDS differential data input , [B2-B5, HS, VS, DE]
16	V _{SS}	GND
17	RxCLKIN-	Negative LVDS differential clock input
18	RxCLKIN+	Positive LVDS differential clock input
19	V _{SS}	GND
20	NC	Non-Connection
21	NC	Non-Connection
22	NC	Non-Connection
23	NC	Non-Connection
24	NC	Non-Connection
25	NC	Non-Connection
26	NC	Non-Connection
27	NC	Non-Connection
28	NC	Non-Connection
29	NC	Non-Connection
30	NC	Non-Connection

CN2 CCFL POWER SOURCE (BHSR-02VS-1/JAPAN SOLDERLESS TERMINAL MFG CO., LTD.)

[Mating Connector : SM02B-BHS-1/JAPAN SOLDERLESS TERMINAL MFG CO., LTD.]

Terminal No.	Symbol	Function
1	V _{FLH}	CCFL POWER SUPPLY (HIGH VOLTAGE)
2	V _{FLL}	CCFL POWER SUPPLY (LOW VOLTAGE)

Note 1) Please connect NC pin to nothing. Don't connect it to ground nor to other signal input.

Please connect GND to ground. Don't use it as no-connect nor connection with high impedance.

Note 2) 262,144 colors are displayed by the combinations of 18 bits data. (See next page)

RECOMMENDED TRANSMITTER (DS90C383) TO LTD154EX0V INTERFACE ASSIGNMENT

Input Terminal No.		Input Signal (Graphics controller output signal)		Output Signal Symbol	To LTD154EX0V Interface(CN1)	
Symbol	DS90CF365	Symbol	Function		Terminal	Symbol
T1IN0	51	R0	Red Pixels Display Data (LSB)	TOUT0- TOUT0+	No. 8 No. 9	RxIN0- RxIN0+
T1IN1	52	R1	Red Pixels Display Data			
T1IN2	54	R2	Red Pixels Display Data			
T1IN3	55	R3	Red Pixels Display Data			
T1IN4	56	R4	Red Pixels Display Data			
T1IN5	3	R5	Red Pixels Display Data (MSB)			
T1IN6	4	G0	Green Pixels Display Data (LSB)			
T1IN7	6	G1	Green Pixels Display Data	TOUT1- TOUT1+	No.11 No.12	RxIN1- RxIN1+
T1IN8	7	G2	Green Pixels Display Data			
T1IN9	11	G3	Green Pixels Display Data			
T1IN10	12	G4	Green Pixels Display Data			
T1IN11	14	G5	Green Pixels Display Data (MSB)			
T1IN12	15	B0	Blue Pixels Display Data (LSB)			
T1IN13	19	B1	Blue Pixels Display Data			
T1IN14	20	B2	Blue Pixels Display Data	TOUT2- TOUT2+	No.14 No.15	RxIN2- RxIN2+
T1IN15	22	B3	Blue Pixels Display Data			
T1IN16	23	B4	Blue Pixels Display Data			
T1IN17	24	B5	Blue Pixels Display Data (MSB)			
T1IN18	27	HSYNC	Horizontal Synchronized Signal			
T1IN19	28	VSYNC	Vertical Synchronized Signal			
T1IN20	30	DE	Data Enable			
T1IN21	50	NC	Non Connection (open)	TOUT3- TOUT3+	-	-
T1IN22	2	NC	Non Connection (open)			
T1IN23	8	NC	Non Connection (open)			
T1IN24	10	NC	Non Connection (open)			
T1IN25	16	NC	Non Connection (open)			
T1IN26	18	NC	Non Connection (open)			
T1IN27	25	NC	Non Connection (open)			
T1CLK IN	31	NCLK	Data Sampling Clock	TCLK OUT- TCLK OUT+	No.17 No.18	RxCLKIN - RxCLKIN +

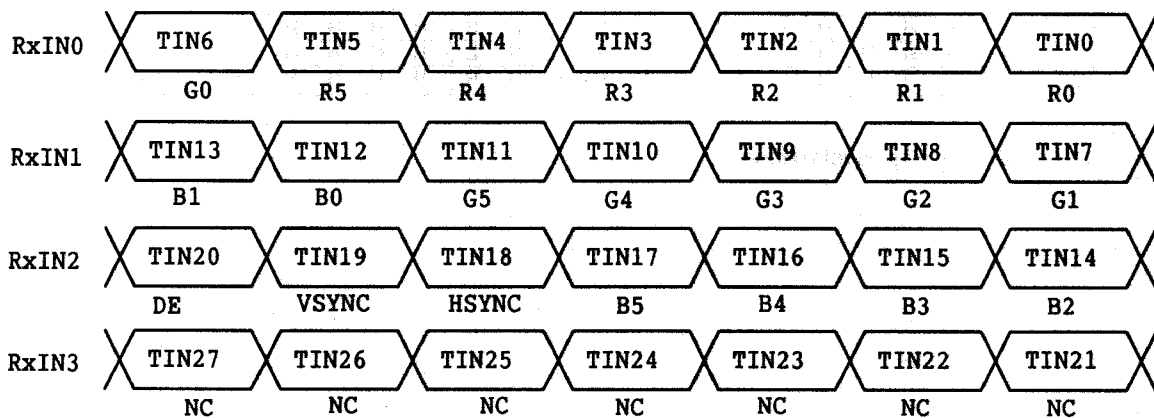

2.4.6 Colors Combination Table

	Display	R5 R4 R3 R2 R1 R0	G5 G4 G3 G2 G1 G0	B5 B4 B3 B2 B1 B0	Gray ScaleLevel
Basic Color	Black	L L L L L L	L L L L L L	L L L L L L	-
	Blue	L L L L L L	L L L L L L	H H H H H H	-
	Green	L L L L L L	H H H H H H	L L L L L L	-
	Light Blue	L L L L L L	H H H H H H	H H H H H H	-
	Red	H H H H H H	L L L L L L	L L L L L L	-
	Purple	H H H H H H	L L L L L L	H H H H H H	-
	Yellow	H H H H H H	H H H H H H	L L L L L L	-
	White	H H H H H H	H H H H H H	H H H H H H	-
Gray Scale of Red	Black	L L L L L L	L L L L L L	L L L L L L	L 0
	Dark ↑ ↓ Light	L L L L L H	L L L L L L	L L L L L L	L 1
		L L L L L L	L L L L L H	L L L L L L	L 2
		:	:	:	L3... L60
	Light	H H H H L H	L L L L L L	L L L L L L	L61
		H H H H H L	L L L L L L	L L L L L L	L62
	Red	H H H H H H	L L L L L L	L L L L L L	Red L63
Gray Scale of Green	Black	L L L L L L	L L L L L L	L L L L L L	L 0
	Dark ↑ ↓ Light	L L L L L L	L L L L L H	L L L L L L	L 1
		L L L L L L	L L L L L H	L L L L L L	L 2
		:	:	:	L3... L60
	Light	L L L L L L	H H H H L H	L L L L L L	L61
		L L L L L L	H H H H H L	L L L L L L	L62
	Green	L L L L L L	H H H H H H	L L L L L L	Green L63
Gray Scale of Blue	Black	L L L L L L	L L L L L L	L L L L L L	L 0
	Dark ↑ ↓ Light	L L L L L L	L L L L L L	L L L L L H	L 1
		L L L L L L	L L L L L L	L L L L H L	L 2
		:	:	:	L3... L60
	Light	L L L L L L	L L L L L L	H H H H L H	L61
		L L L L L L	L L L L L L	H H H H H L	L62
	Blue	L L L L L L	L L L L L L	H H H H H H	Blue L63
Gray Scale of White & Black	Black	L L L L L L	L L L L L L	L L L L L L	L 0
	Dark ↑ ↓ Light	L L L L L H	L L L L L H	L L L L L H	L 1
		L L L L H L	L L L L H L	L L L L H L	L 2
		:	:	:	L3... L60
	Light	H H H H L H	H H H H L H	H H H H L H	L61
		H H H H H L	H H H H H L	H H H H H L	L62
	White	H H H H H H	H H H H H H	H H H H H H	white L63

Note1 L: Low level voltage, H: High level voltage

3. Recommended Operating Conditions ^{1) 2) 3) 7)}

Item	Symbol	Min.	Typ.	Max.	Unit	Remarks
Supply Voltage ⁴⁾	V_{DD}	3.0	3.3	3.6	V	
Comon Mode Input Voltage	V_{CM}	1.0	1.25	2.0	V	
Differential Input High Threshold	V_{TH}	-	-	100	mV	$V_{CM} = 1.25$
Differential Input Low Threshold	V_{TL}	-100	-	-	mV	$V_{CM} = 1.25$
FL Input Current ^{6) 7) 8)}	I_{FL}	2.0	6.0	6.5	mA(rms)	
FL Driving Voltage ⁶⁾	V_{FL}	890	710	690	V(rms)	$I_{FL} = 6.0\text{mA(rms)}$ (Reference)
FL Driving Frequency ⁶⁾	f_{FL}	40	50	60	kHz	
FL Starting Voltage ^{6) 9)}	V_{SFL}	1550	-	1800	V(rms)	0°C

Note 1) The module should be always operated within these ranges. The "Typ." shows the recommendable value.

2) Recommended LVDS transmitter: DS90C383 (made by National semiconductor)

Panel Controller contains LVDS, which is based on LVDS RX3 (made by Epson) specification.

3) Checked Pin Terminal: V_{DD} , GND (0V)

4) Checked Pin Terminal: IN0~CLK+, GND (0V)

Measure: $|V_{IN0+} - V_{IN0-}|$, $|V_{IN1+} - V_{IN1-}|$, $|V_{IN2+} - V_{IN2-}|$
 $|V_{CLKN+} - V_{CLK-}|$

Measure: $(V_{IN0+} - V_{IN0-})/2$, $(V_{IN1+} - V_{IN1-})/2$,

$(V_{IN2+} - V_{IN2-})/2$,

$(V_{CLK+} - V_{CLK-})/2$,

5) Checked Pin Terminal: V_{FLH} - F_{FL}

6) If FL input current (I_{FL}) is higher than typical value(6.0mA(rms)), then FL lifetime becomes shorter.

7) Measuring Method of I_{FL} .

8) Input FL starting voltage (V_{SFL}) should not be less than one second.

If it were less than one second, it may cause unstable operation of FL.

9) Please adjust LCD operating signal timing and FL driving frequency, to optimize the display quality.

There is a possibility that flicker is observed by the interference of LCD operating signal timing and FL driving condition (especially driving frequency), even if the condition satisfies above recommended operating conditions and timing specifications shown in 2.4.4.

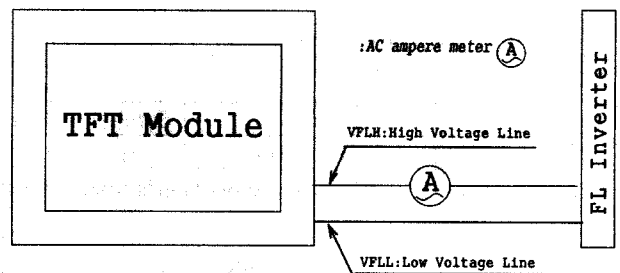

4. Electrical Characteristics

4.1 Test Conditions

Ambient Temperature : T_a 25±5°C
 Ambient Humidity : H_a 65±20%(RH)
 Supply Voltage : V_{DD} 3.3V
 Input Signal : Refer typical value in "2.4.4 Timing Specifications".
 FL Input Current : I_{FL} =6.0mA(rms)
 FL Driving Frequency : f_{FL} =50kHz
 FL inverter : HIU-757A (Harison)

Input Signal : Refer typical value in "2.4.4 Timing Specifications".

4.2 Specifications

Item	Symbol	Min.	Typ. ¹⁾	Max.	Unit	Remark
Current Consumption	I_{DD}	-	260	450	mA	V_{DD} Terminal Current

Note 1) The Typical value of I_{DD} is measured in the following pattern.

1. White
2. Yellow
3. Purple
4. Red
5. Light Blue
6. Green
7. Blue
8. Black

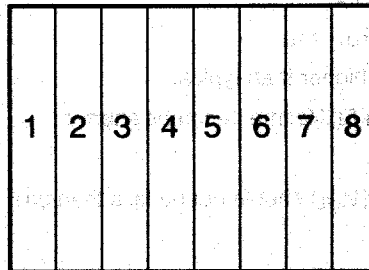

5. Optical Characteristics

5.1 Test Conditions

It is same as 4.1

The measuring method is shown in 11.

5.2 Optical Specifications ¹⁾

Item	Symbol	Conditions	Specifications			Unit	Remark	
			Min.	Typ	Max.			
Viewing Angle	θ	$CR >= 10$	$\phi = 180^\circ$	30	40	-	°	
			$\phi = 0^\circ$	40	50	-	°	
			$\phi = 90^\circ$	40	50	-	°	
			$\phi = -90^\circ$	40	50	-	°	
Contrast Ratio	CR	$\theta = 0^\circ, \phi = 0^\circ$	300	-	-	-		
Response Time	$t_{ON} + t_{OFF}$	$\theta = 0^\circ, \phi = 0^\circ$	-	-	50	ms		
Luminance	L	$\theta = 0^\circ, \phi = 0^\circ$ Gray Scale Level=L63 (White)	155	190	220	cd/m ²	$I_{FL}=6.5mA(rms)$	
Luminance Uniformity	LUNF	$\theta = 0^\circ, \phi = 0^\circ$ Gray Scale Level=L63 (White)	55	-	-	%	L_{min} / L_{max}	
Chromaticity	Red	X_R	Gray Scale Level:L63 $\theta = 0^\circ, \phi = 0^\circ$	0.564	0.614	0.664	-	
		Y_R		0.283	0.333	0.383	-	
	Green	X_G	Ditto	0.243	0.293	0.343	-	
		Y_G		0.483	0.533	0.583	-	
	Blue	X_B	Ditto	0.096	0.146	0.196	-	
		Y_B		0.060	0.110	0.160	-	
	White	X_W	Ditto	0.283	0.313	0.343	-	
		Y_W		0.299	0.329	0.359	-	

Note 1): Refer to "11. Measuring Method".

Note 2): The above test limit must be applied for initial use. Characteristics will be shifted by long period operation, but it is not irregular phenomena. Theoretically brightness characteristics will be decreased due to CCFL degradation and color shift due to optical components change.

6. Quality

6.1 Inspection AQL

Total of Major Defects : AQL 0.65 %

Total of Minor Defects : AQL 1.5 %

Sampling Method: ANSI/ ASQC Z1.4 (level II)

6.2 Test Conditions

- 1) Ambient Temperature : $25 \pm 5^{\circ}\text{C}$
- 2) Ambient Humidity : $65 \pm 20\%$ (RH)
- 3) Illumination : Approximately 500 lx under the fluorescent lamp
- 4) Viewing Distance : Approximately 0.3m by the eyes of the inspector from the module
- 5) Inspection Angle : $\theta = 0^{\circ}$, $\phi = 0^{\circ}$

6.3 Dimensional Outline

The products shall conform to the dimensions specified in 2.3.2.

Definition of Major and Minor defects are as follows.

Item	Description	Class
Important Dimensions	Dimensional outline, Dimensional between the mounting holes(hinge)	Major
Others	Dimensions specified in this specifications	Minor

6.4 Appearance Test

6.4.1 Test Conditions

1) Condition : Non-operating, operating (Pattern : L63 white raster)

Same as 6.2

6.4.2 Specifications

Item	Description	Class									
PCB Appearance	Pattern peeling snapping, electrically short	Major									
	Repair portion on PCB is not covered by epoxy resin	Minor									
Soldering	Cold solder joint, lead move when pulled	Major									
Bezel, Frame, Connectors	Distinct stain, rust or scratch	Minor									
Bright Lines ¹⁾ (Light Lint)	<table border="1"> <thead> <tr> <th>Line width(mm)</th> <th>Length(mm)</th> <th>Acceptable count</th> </tr> </thead> <tbody> <tr> <td>$0.03 < W \leq 0.152$</td> <td>$L \leq 2.03$</td> <td>$n \leq 4$</td> </tr> <tr> <td>$0.152 < W$</td> <td>$2.03 < L$</td> <td>0</td> </tr> </tbody> </table>	Line width(mm)	Length(mm)	Acceptable count	$0.03 < W \leq 0.152$	$L \leq 2.03$	$n \leq 4$	$0.152 < W$	$2.03 < L$	0	Minor
	Line width(mm)	Length(mm)	Acceptable count								
	$0.03 < W \leq 0.152$	$L \leq 2.03$	$n \leq 4$								
$0.152 < W$	$2.03 < L$	0									
Dark Lines ¹⁾ (Dark Lint/Hair)	<table border="1"> <thead> <tr> <th>Line width(mm)</th> <th>Length(mm)</th> <th>Acceptable count</th> </tr> </thead> <tbody> <tr> <td>$0.03 < W \leq 0.1$</td> <td>$0.3 < L \leq 1.0$</td> <td>$n \leq 4$</td> </tr> <tr> <td>$0.1 < W$</td> <td>$1.0 < L$</td> <td>0</td> </tr> </tbody> </table>	Line width(mm)	Length(mm)	Acceptable count	$0.03 < W \leq 0.1$	$0.3 < L \leq 1.0$	$n \leq 4$	$0.1 < W$	$1.0 < L$	0	
	Line width(mm)	Length(mm)	Acceptable count								
	$0.03 < W \leq 0.1$	$0.3 < L \leq 1.0$	$n \leq 4$								
$0.1 < W$	$1.0 < L$	0									
Black and White Spots ¹⁾²⁾	<table border="1"> <thead> <tr> <th>Average diameter(mm)</th> <th>Acceptable count/side</th> </tr> </thead> <tbody> <tr> <td>$0.25 < D \leq 0.4$</td> <td>$n \leq 3$</td> </tr> <tr> <td>$0.4 < D$</td> <td>0</td> </tr> </tbody> </table>	Average diameter(mm)	Acceptable count/side	$0.25 < D \leq 0.4$	$n \leq 3$	$0.4 < D$	0				
	Average diameter(mm)	Acceptable count/side									
	$0.25 < D \leq 0.4$	$n \leq 3$									
$0.4 < D$	0										
Polarizer Scratch ¹⁾	<table border="1"> <thead> <tr> <th>Line width(mm)</th> <th>Length(mm)</th> <th>Acceptable count</th> </tr> </thead> <tbody> <tr> <td>$0.01 < W \leq 0.05$</td> <td>$1.0 < L \leq 10.0$</td> <td>$n \leq 3$</td> </tr> <tr> <td>$0.05 < W$</td> <td>$10.0 < L$</td> <td>0</td> </tr> </tbody> </table>	Line width(mm)	Length(mm)	Acceptable count	$0.01 < W \leq 0.05$	$1.0 < L \leq 10.0$	$n \leq 3$	$0.05 < W$	$10.0 < L$	0	
	Line width(mm)	Length(mm)	Acceptable count								
	$0.01 < W \leq 0.05$	$1.0 < L \leq 10.0$	$n \leq 3$								
$0.05 < W$	$10.0 < L$	0									
Polarizer Dents ¹⁾²⁾	<table border="1"> <thead> <tr> <th>Average diameter(mm)</th> <th>Acceptable count</th> </tr> </thead> <tbody> <tr> <td>$0.127 < D \leq 0.38$</td> <td>$n \leq 3$</td> </tr> <tr> <td>$0.38 < D$</td> <td>0</td> </tr> </tbody> </table>	Average diameter(mm)	Acceptable count	$0.127 < D \leq 0.38$	$n \leq 3$	$0.38 < D$	0				
	Average diameter(mm)	Acceptable count									
	$0.127 < D \leq 0.38$	$n \leq 3$									
$0.38 < D$	0										
Polarizer Bubble ¹⁾²⁾	<table border="1"> <thead> <tr> <th>Average diameter(mm)</th> <th>Acceptable count</th> </tr> </thead> <tbody> <tr> <td>$0.254 < D \leq 0.38$</td> <td>$n \leq 3$</td> </tr> <tr> <td>$0.38 < D$</td> <td>0</td> </tr> </tbody> </table>	Average diameter(mm)	Acceptable count	$0.254 < D \leq 0.38$	$n \leq 3$	$0.38 < D$	0				
	Average diameter(mm)	Acceptable count									
	$0.254 < D \leq 0.38$	$n \leq 3$									
$0.38 < D$	0										

Note 1) Inspection area should be within active area.

Note 2) Dusts which are bigger not less than 0.10mm ($0.1 < W$) shall be judged by "Average Diameter".

Average Diameter $D = (a+b) / 2$ (mm)

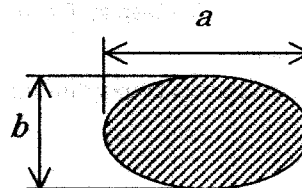

6.5 Display Quality

6.5.1 Test Conditions

- 1) Inspection Area : Within active area
- 2) Driving Condition : Same as test conditions shown in 4.1 and 6.2
- 3) Test Pattern : White display pattern (gray scale level L63) and black display pattern (gray scale level L0)

6.5.2 Specifications ⁴⁾

Item	Description / Specifications	Class
Function	No display, Malfunction	Major
Display Quality ¹⁾	Missing line	Major
	Missing Sub-Pixels	Major
	1) Red and Blue Bright (High and Low) defects ²⁾³⁾⁴⁾⁵⁾⁶⁾	2pcs. max.
	2) Green bright (High and Low) defects ²⁾³⁾⁴⁾⁵⁾⁶⁾	0pcs. max.
	3) Dark defects ²⁾⁴⁾	3pcs. max.
	4) Green high bright defect to green high bright defect distance	-
	5) High bright defect to high bright defect distance	50mm min.
	6) High bright defect to low bright defect and low bright defect to low bright defect distance	25mm min.
	7) Dark defect to dark defect distance	25mm min.
	8) Low bright defect conjunction (2 sub-pixels)	0 sets max.
9) Dark defect conjunction	2 sets max.	
	Inconspicuous flicker, crosstalk, Newton's ring, Mottling Rubbing defect, Dim Lines, Horizontal Line and Vertical Line. : neglect	Major
	Minimum distance between ANY allowable defect ⁵⁾ : 25.4mm min.	Major
	Maximum number of ALL allowable defects : 9 pcs. max.	Major

Note 1) Defects of both color filter and black matrix are counted as bright or dark defects.

Inspection area should be within the active area.

Note 2) Bright defect means a bright spot(sub-pixel) on the display pattern of gray scale L0.

Dark defect means a dark spot(sub-pixel) on the display pattern of gray scale L63.

Note 3) Bright defect visible through the 2% ND-Filter are to be considered high level defects.

Those visible through the 5% ND-Filter are to be considered low level defects.

Note 4) Testing is conducted only on RED, GREEN, BLUE, WHITE of gray scale L63, RED, GREEN, BLUE of gray scale L31, and BLACK of gray scale L0.

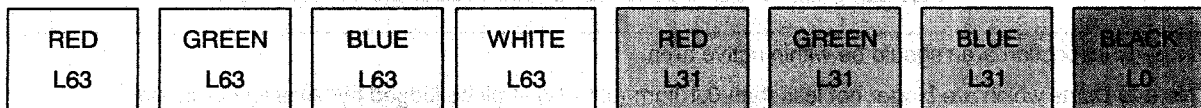

Note 5) Toshiba Matsushita Display Technology counts minimum distance between ANY allowable defects on white L63 screen only.

Note 6) Toshiba Matsushita Display Technology shall have >95% of deliveries with Zero Bright Dot Defects in the month.

6.6 Reliability Test

6.6.1 Test Conditions

- 1) The module should be driven and inspected under normal test conditions.
- 2) The module should not have condensation of water (moisture) on the module.
- 3) The module should be inspected after two or more hours storage in normal conditions (15 - 35°C, 45 - 65%(RH)).
- 4) A module shall be used only for one test.

6.6.2 Specifications

The module shall have no failure in the following reliability test items.

Test Item	Test Conditions	Result
High Temperature Operation ¹⁾	50°C 192 h	3p/3p OK
High Temperature Storage ²⁾	60°C 192 h	3p/3p OK
High Temperature and High Humidity operation ¹⁾	50°C 80% 192 h	3p/3p OK
Low Temperature Operation ¹⁾	0°C 192 h	3p/3p OK
Low Temperature Storage ²⁾	-20°C 192 h	3p/3p OK
Temperature Shock ²⁾	-20°C ↔ 60°C 0.5h 0.5h 50 cycles	3p/3p OK
Mechanical Vibration ²⁾	10 - 200 - 10Hz sweep/cycle, 1.5×9.8m/s ² constant, X.Y.Z each direction, 0.5h each	3p/3p OK
Mechanical Shock ²⁾	50×9.8m/s ² , 20ms, ±X, ±Y, ±Z each direction, one time each	3p/3p OK

Note 1) Operating

Note 2) Non-Operating

Definitions of failure for judgment shall be as follows:

- 1) Function of the module should be maintained.
- 2) Current consumption should be smaller than the specified value.
- 3) Appearance and display quality should not have distinguished degradation.
- 4) Luminance should be larger than 50% of the minimum value specified in 5.2.

6.7 Labels

(1) Product Label

Serial number : $\triangle\triangle$ \blacktriangle 3A 000001

① ② ③ ④

① : Module type code

② : Manufacturing code

③ : Lot code 3 A

(1) (2)

(1):Year code-end of the A.D.

(2):Month code-alphabet→ Jan. : A - Dec. : L

(Example: 3A→2003 JAN.)

④:Serial code

decimal, 6 figures

Bar code: CODE-39 High-density

•There are two type of label according to country of origin.

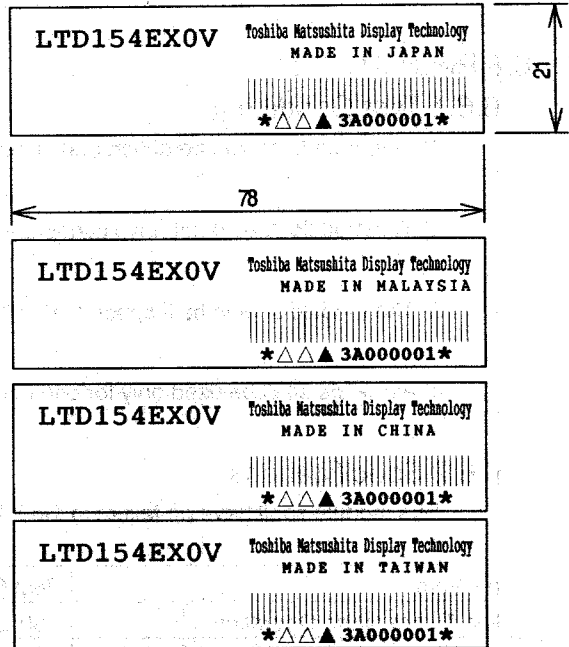

(2) Caution Labels

• High Voltage

• Disposal of CCFL

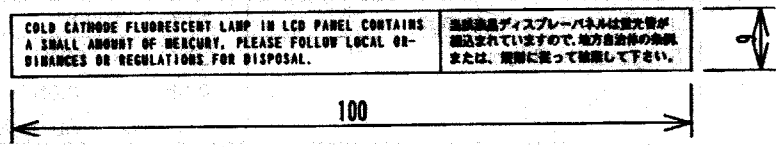
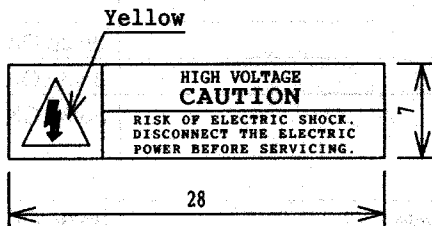

Unit: mm

(3) Label Locations

(1) : Product Label

(2) : High Voltage Label

(3) : Disposal Label

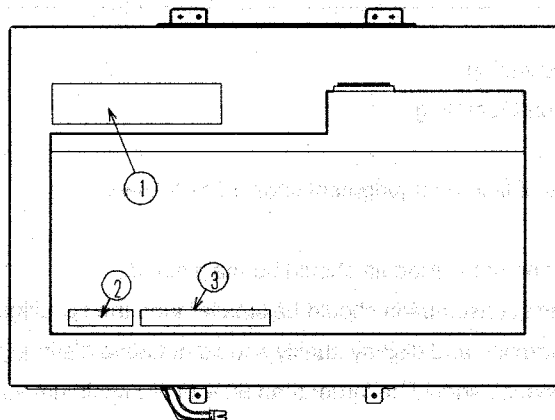

7. Lifetime

7.1 Module (except lamp)

MTTF (Mean Time To Failure) : 50,000 h

(This value is not assurance time but inference value by following conditions.)

Conditions : Ambient temperature : 25±5°C (No wind)

Ambient humidity : 65%(RH)

7.2 Lamp

7.2.1 Test Conditions

Ambient temperature : 25±5°C (No wind)

Lamp current : 6.5 mA(rms)

Lighting condition : continuous lighting

Driving frequency : 50kHz

7.2.2 Specifications

MTBF : 10,000 h

Definitions of failure for judgment shall be as follows.

- 1) LCD luminance becomes half of the minimum value specified in 5.2.
- 2) Lamp doesn't light normally.

Note 1): In case of LCD long period operation, discoloration of light guide or optical sheet will be happened due to ultra violet and heat from CCFL. As the result, there is possibility to have out of specification for the optical characteristics as "5.2". But this is a not irregular phenomena. Moreover, CCFL also has the characteristic of color shift by long period operation.

8. Packaging

8.1 Carton (internal package)

(1) Packaging Form

Corrugated cardboard box

(2) Packaging Method

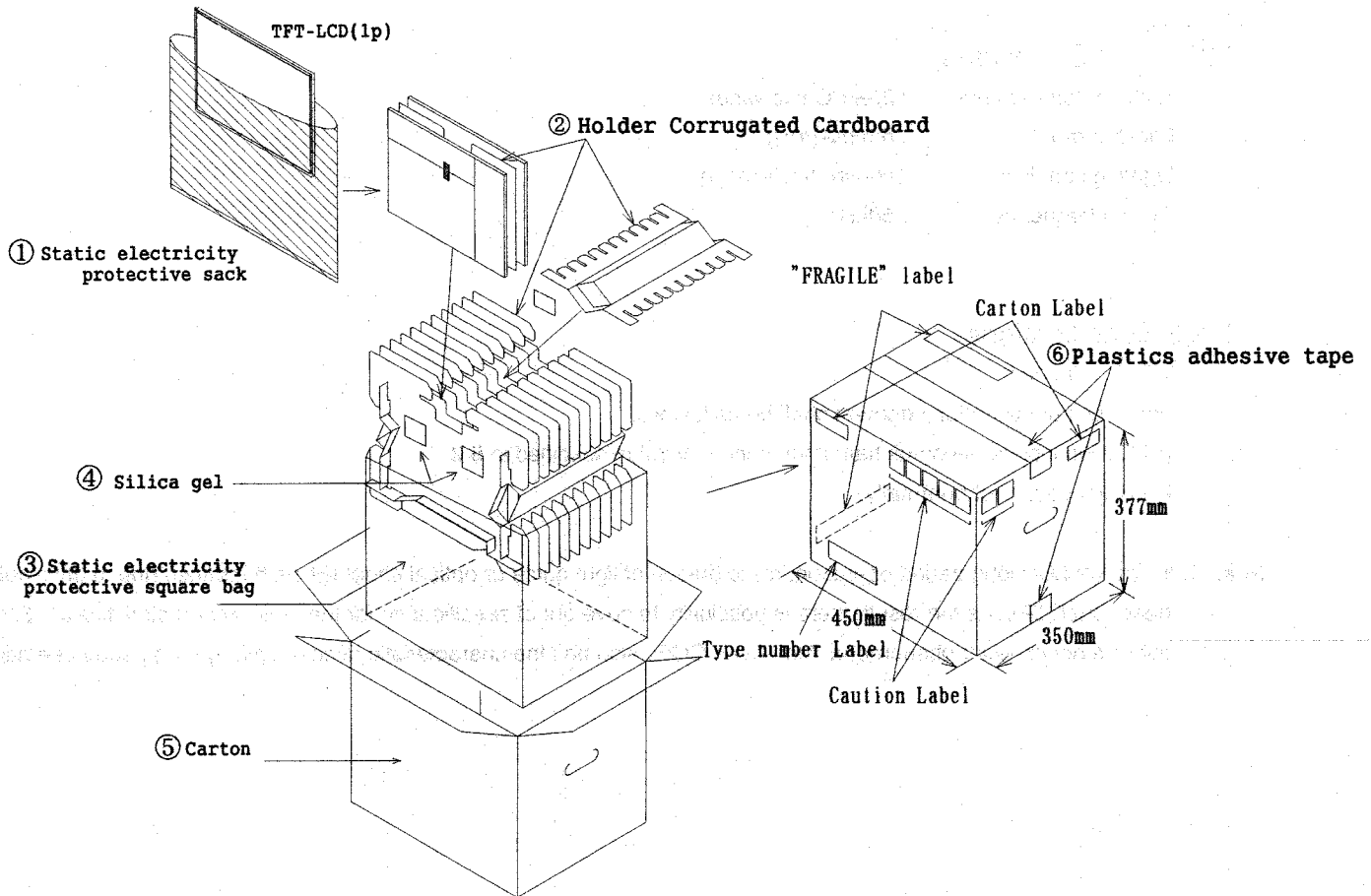

Note 1) Total weight : (Approx.) 14.5 kg

Note 2) Acceptable number of piling : 6 sets

(3) Packaging Material

Number	Quantity	Description
1	20	Static electricity protective sack
2	1 set	Holder (inner box)
3	1	Static electric protective square bag
4	3	Silicagel (100g x 3)
5	1 set	Carton
6		Plastic adhesive tape

9. Warranty

Warranty clause will be decided separately.

10. Regulation

The set (which our LCD module is assembled into) to conform the regulations below, take measures in set side. Toshiba Matsushita Display Technology is not liable for the regulations to the complete set, nor can guarantee our LCD module conform the regulation by itself.

a) Examples of EMI Regulations

FCC : PART15 CLASS B

VCCI : CLASS B

CISPR : CLASS B

b) Examples of Safety Regulations

IEC 950

UL 1950

11. Measuring Method

11.1 Measuring System

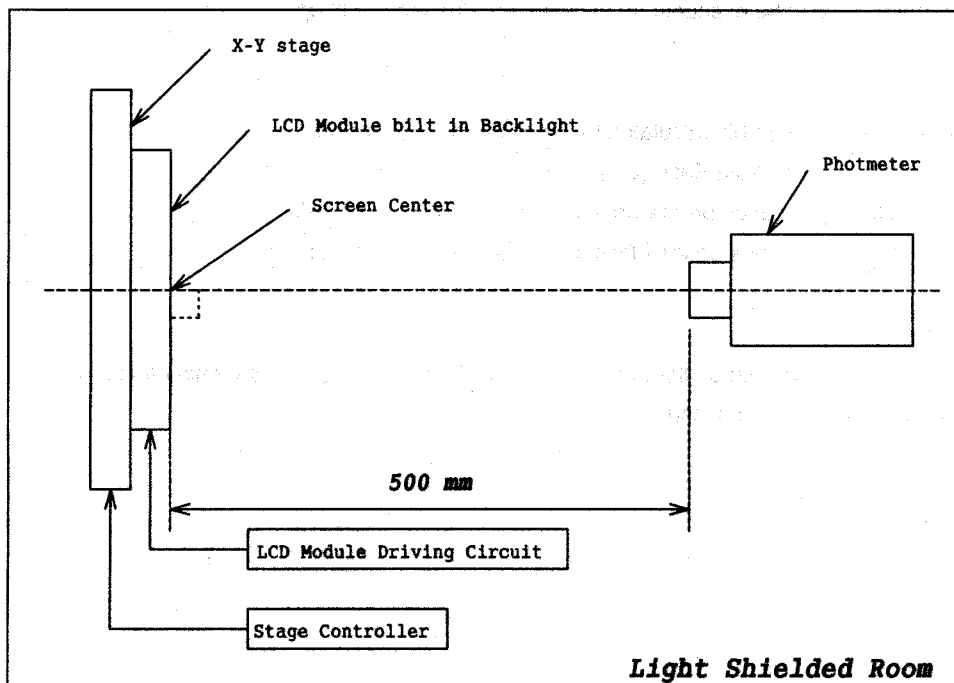

(1) The measurement point is the center of the active area except for the measurement of Luminance Uniformity.

(2) Photometer : BM-5A / BM-7 TOPCON (Aperture 2deg.)

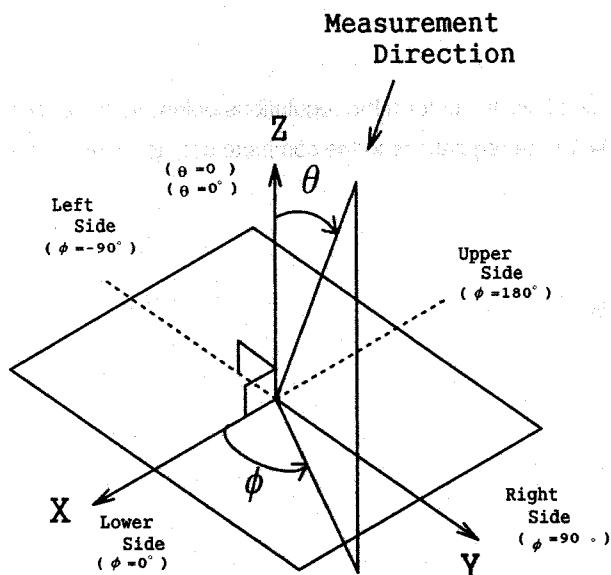
(3) Definition of ϕ and θ :

11.2 Measuring Methods

(1) Luminance:

The luminance of the center on a white raster (gray scale level L63) shall be measured.
Measurement shall be executed 30 minutes after the lamp is lit up.

(2) Contrast Ratio:

The contrast ratio can be calculated by the following expression.

$$\text{Contrast Ratio (CR)} = L63 / L0$$

L63 : Luminance on the white raster (gray scale level L63)

L0 : Luminance on the black raster (gray scale level L0)

(3) Viewing Angle

Viewing angle is defined as the angles(θ, ϕ), in which specified contrast ratio can be obtained.
(Refer to 11.1(3) for the axes.)

(4) Luminance Uniformity:

The Luminance should be measured at 9 positions on white raster(gray scale level L63).
 Uniformity can be calculated by the following expression.

$$\text{Luminance Uniformity} = \frac{\text{Minimum Luminance}}{\text{Maximum Luminance}} \times 100\%$$

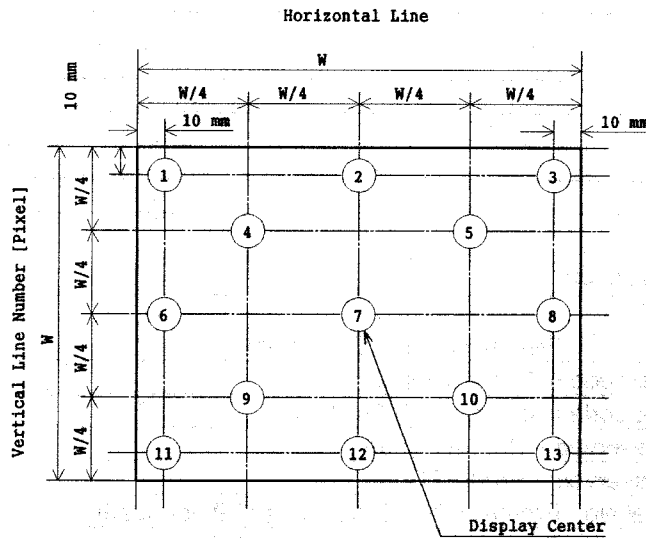

(5) Chromaticity :

The values(x,y) of chromaticity coordinates should be measured for the White, Red, Green and Blue Raster(gray scale level L63) each with a photometer.

(6) Response Time :

The response time (t_{ON} , t_{OFF}) is measured with a photo detector (photodiode) which measures the light intensity of the pixels.

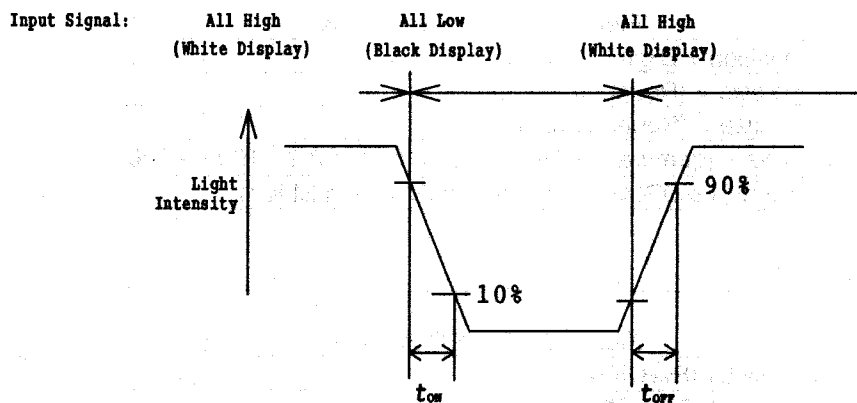

t_{ON} : Turn on time is the time for a photo detector output waveform to go from maximum value to 10% of its maximum.

t_{OFF} : Turn off time is the time for a photo detector output waveform to go from zero to 90% of its maximum.

Photodiode : S1223-01 HAMAMATSU PHOTONICS K.K.

White Display : White Raster (gray scale level L63)

Black Display : Black Raster (gray scale level L0)

12. EDID

This is the EDID data format to support displays as defined in the VESA Plug & Display.

Header

Byte (dec)	Byte (hex)	Field Name and Comments	Value (hex)	Value (binary)
0	00	Header	00	00000000
1	01	Header	FF	11111111
2	02	Header	FF	11111111
3	03	Header	FF	11111111
4	04	Header	FF	11111111
5	05	Header	FF	11111111
6	06	Header	FF	11111111
7	07	Header	00	00000000

Vendor / Product ID / EDID Version

Byte (dec)	Byte (hex)	Field Name and Comments	Value (hex)	Value (binary)
8	08	EISA manufacture code = 3 Character ID	30	00110000
9	09	EISA manufacture code (Compressed ASCII)	64	00011010
10	0A	Panel Supplier Reserved – Product Code	00	00000000
11	0B	Panel Supplier Reserved – Product Code	58	01010000
12	0C	LCD module Serial No - Preferred but Optional ("0" if not used)	01	00000001
13	0D	LCD module Serial No - Preferred but Optional ("0" if not used)	01	00000001
14	0E	LCD module Serial No - Preferred but Optional ("0" if not used)	01	00000001
15	0F	LCD module Serial No - Preferred but Optional ("0" if not used)	01	00000001
16	10	Week of manufacture		Value
17	11	Year of manufacture		Value
18	12	EDID structure version # =	01	00000001
19	13	EDID revision # =	03	00000011

Display Parameters

Byte (dec)	Byte (hex)	Field Name and Comments	Value (hex)	Value (binary)
20	14	Video I/P definition = Digital I/P (80h)	80	10000000
21	15	Max H image size = (Rounded to cm)	21	00100001
22	16	Max V image size = (Rounded to cm)	15	00010101
23	17	Display gamma = (gamma × 100) - 100 = Example: (2.2 × 100) - 100 = 120	78	01111000
24	18	Feature support (no DPMS, Active off, RGB, timing BLK 1)	0A	00001010

Panel Color Coordinates

Byte (dec)	Byte (hex)	Field Name and Comments	Value (hex)	Value (binary)
25	19	Red/Green Low bit (RxRy/GxGy)	87	10000111
26	1A	Blue/White Low bit (BxBY/WxWy)	F5	11110101
27	1B	Red X	94	10010100
28	1C	Red Y	57	01010111
29	1D	Green X	4F	01001111
30	1E	Green Y	8C	10001100
31	1F	Blue X	27	00100111
32	20	Blue Y	27	00100111
33	21	White X	50	01010000
34	22	White Y	54	01010100

Toshiba Matsushita Display Technology Co.,Ltd

Date:2003-08-05

New No. NL-LTD154EX0V-01

Date: - -

Old No.

Established Timings

Byte (dec)	Byte (hex)	Field Name and Comments	Value (hex)	Value (binary)
35	23	Established timings 1 (00h if not used)	00	00000000
36	24	Established timings 2 (00h if not used)	00	00000000
37	25	Manufacturer's timings (00h if not used)	00	00000000

Standard Timing ID

Byte (dec)	Byte (hex)	Field Name and Comments	Value (hex)	Value (binary)
38	26	Standard timing ID1 (01h if not used)	81	10000001
39	27	Standard timing ID1 (01h if not used)	00	00000000
40	28	Standard timing ID2 (01h if not used)	01	00000001
41	29	Standard timing ID2 (01h if not used)	01	00000001
42	2A	Standard timing ID3 (01h if not used)	01	00000001
43	2B	Standard timing ID3 (01h if not used)	01	00000001
44	2C	Standard timing ID4 (01h if not used)	01	00000001
45	2D	Standard timing ID4 (01h if not used)	01	00000001
46	2E	Standard timing ID5 (01h if not used)	01	00000001
47	2F	Standard timing ID5 (01h if not used)	01	00000001
48	30	Standard timing ID6 (01h if not used)	01	00000001
49	31	Standard timing ID6 (01h if not used)	01	00000001
50	32	Standard timing ID7 (01h if not used)	01	00000001
51	33	Standard timing ID7 (01h if not used)	01	00000001
52	34	Standard timing ID8 (01h if not used)	01	00000001
53	35	Standard timing ID8 (01h if not used)	01	00000001

Timing Descriptor #1

Byte (dec)	Byte (hex)	Field Name and Comments	Value (hex)	Value (binary)
54	36	Pixel Clock/10,000 (LSB)	58	01011000
55	37	Pixel Clock/10,000 (MSB)	1B	0001101
56	38	Horizontal Active = xxx pixels (lower 8 bits) Note	00	00000000
57	39	Horizontal Blanking (Thbp) = xxx pixels (lower 8 bits)	A0	10100000
58	3A	Horizontal Active/Horizontal blanking (Thbp) (upper4:4 bits)	50	01010000
59	3B	Vertical Active = xxx lines	20	0010000
60	3C	Vertical Blanking (Tvbp) = xxx lines (DE Blanking min for DE only panels)	17	00010111
61	3D	Vertical Active : Vertical Blanking (Tvbp) (upper4:4 bits)	30	00110000
62	3E	Horizontal Sync, Offset (Thfp) = xxx pixels	30	00110000
63	3F	Horizontal Sync, Pulse Width = xxx pixels	20	00100000
64	40	Vertical Sync, Offset (Tvfp) = xx lines Sync Width = xx lines	26	00100110
65	41	Horizontal Vertical Sync Offset/Width upper 2 bits	00	00000000
66	42	Horizontal Image Size =xxx mm	4C	01001100
67	43	Vertical image Size = xxx mm	D0	11010000
68	44	Horizontal Image Size / Vertical image size	10	00010000
69	45	Horizontal Border = 0 (Zero for Notebook LCD)	00	00000000
70	46	Vertical Border = 0 (Zero for Notebook LCD)	00	00000000
71	47	EDID Standard	18	00011000

Timing Descriptor #2 Manufacturer's Specified Range Timing Descriptor

Byte (dec)	Byte (hex)	Field Name and Comments	Value (hex)	Value (binary)
72	48	Header : 00 00 00 0F 00	00	00000000
73	49		00	00000000
74	4A		00	00000000
75	4B		0F	00001111
76	4C		00	00000000
77	4D	Value = $HSPW_{min} / 2$ (pixel clks)	04	00000100
78	4E	Value = $HSPW_{max} / 2$ (pixel clks)	18	00011000
79	4F	Value = $Thbp_{min} / 2$ (pixel clks)	08	00001000
80	50	Value = $Thbp_{max} / 2$ (pixel clks)	64	01100100
81	51	Value = $VSPW_{min} / 2$ (line pulses)	00	00000000
82	52	Value = $VSPW_{max} / 2$ (line pulses)	10	00010000
83	53	Value = $Tvbp_{min} / 2$ (line pulses)	02	00000010
84	54	Value = $Tvbp_{max} / 2$ (line pulses)	1E	00011110
85	55	$Thp_{min} = value * 2 + HA_{pixel\ clks}$ (pixel clks) Note	0C	00001100
86	56	$Thp_{max} = value * 2 + HA_{pixel\ clks}$ (pixel clks) Note	7F	01111111
87	57	$Tvp_{min} = value * 2 + VA_{lines}$ (line pulses)	02	00000010
88	58	$Tvp_{max} = value * 2 + VA_{lines}$ (line pulses)	20	00100000
89	59	Module "A" Revision = Example: 00, 01, 02, 03, etc.	00	00010001

Timing Descriptor #3

Byte (dec)	Byte (hex)	Field Name and Comments	Value (hex)	Value (binary)
90	5A	Model No. Header : 00 00 00 FE 00 Terminator : 0A Blank : 20	00	00000000
91	5B		00	00000000
92	5C		00	00000000
93	5D		FE	11111110
94	5E		00	00000000
95	5F	Manufacturer P/N : L	4C	01001100
96	60	Manufacturer P/N : T	54	01010100
97	61	Manufacturer P/N : D	44	01000100
98	62	Manufacturer P/N : 1	31	00110001
99	63	Manufacturer P/N : 5	35	00110101
100	64	Manufacturer P/N : 4	34	00110100
101	65	Manufacturer P/N : E	45	01000101
102	66	Manufacturer P/N : X	58	01011000
103	67	Manufacturer P/N : 0	30	00110000
104	68	Manufacturer P/N : V	56	01010110
105	69	Terminator : 0A	0A	00001010
106	6A	Blank : 20	20	00100000
107	6B	Blank : 20	20	00100000

Timing Descriptor #4

Byte (dec)	Byte (hex)	Field Name and Comments	Value (hex)	Value (binary)
108	6C	Module Serial Header : 00 00 00 FF 00 Terminator : 0A Blank : 20	00	00000000
109	6D		00	00000000
110	6E		00	00000000
111	6F		FF	11111111
112	70		00	00000000
113	71	Serial No. :		Value
114	72			Value
115	73			Value
116	74			Value
117	75			Value
118	76			Value
119	77			Value
120	78			Value
121	79			Value
122	7A			Value
123	7B			Value
124	7C	Terminator : 0A	0A	00001010
125	7D	Blank : 20	20	00100000

Byte (dec)	Byte (hex)	Field Name and Comments	Value (hex)	Value (binary)
126	7E	Extension flag (# of optional 128 EDID extension blocks to follow, Typ = 0)	00	00000000
127	7F	Checksum (The 1-byte sum of all 128 bytes in this EDID block shall = 0)	-	-

EDID Notes:

Horizontal Active (HA), byte 38h, is true active pixels. HA_{pixel clks} value, bytes 55 & 56, is HA for XGA and HA/2 for SXGA+ and above resolutions.

*) #78-80: Under Studying

**)#85-88: Under Studying