

Toshiba Matsushita Display Technology Co., Ltd

39cm COLOR TFT-LCD MODULE WITHOUT BACKLIGHT
(15.4 WIDE TYPE)
LTD154EZ0HG
(p-Si TFT)

PRODUCT INFORMATION

FEATURES

- (1) 15.4WIDE-UXGA(1920x1200 pixels) display size for notebook PC
- (2) TFT-LCD Module without backlight
- (3) LVDS interface system (H-Sync, V-Sync)

TENTATIVE

MECHANICAL SPECIFICATIONS

Item	Specifications
Dimensional Outline of Glass (typ.)	339.2(W) x 215.5(H) x 1.49(D) mm
Number of Pixels	1920(W) x 1200(H) pixels
Active Area	331.4 (W) x 207.1(H) mm
Pixel Pitch	0.1725(W) x 0.1725(H)
Weight (approximately)	255 g

ABSOLUTE MAXIMUM RATINGS

Item	Symbol	Min.	Max.	Unit	Checked Terminal
Supply Voltage	V_{DD}	-0.3	+4.0	V	$V_{DD} - GND$
Input Voltage of Signals	V_{IN}	-0.3	$V_{DD}+0.3$	V	LVDS interface
Operating Ambient Temperature	T_{OP}	0	50	°C	
Operating Ambient Humidity	H_{OP}	10	90	%(RH)	
Storage Temperature	T_{STG}	-20	+60	°C	
Storage Humidity	H_{STG}	10	90	%(RH)	
Operating Temperature for Panel	-	0	+60	°C	

ELECTRICAL SPECIFICATION(T.B.D)

Item	Symbol	Min.	Typ.	Max.	Unit	Remarks
Supply Voltage	V_{DD}	3.0	3.3	3.6	V	
Differential Input Voltage ¹⁾	V_{ID}	100	-	600	mV	
Common Mode Input Voltage ¹⁾	V_{CM}	1.0	-	$2.4 - (V_{ID})/2$	V	
Current Consumption	I_{DD}	---	(600)	---	mA	
Power Consumption		---	(2.0)	---	W	

*1) Recommended LVDS transmitter: DS90CF365

OPTICAL SPECIFICATION ($T_a=25^\circ\text{C}$)(T.B.D)

Item	Min.	Typ.	Max.	Unit	Remarks
Contrast Ratio ²⁾ (CR)	(150)	(350)	---	---	
Response Time ²⁾	(t_{ON})	---	50	ms	
	(t_{OFF})	---	50	ms	
Transmittance ²⁾³⁾	(5.1)	(6.0)	---	%	

*2) : This specification is the value at the time of using Toshiba Matsushita Display Technology Co., Ltd. standard light box.

Standard Light Box : Fujicolor Lightbox

Fluorescence lamp : Toshiba-made Mellow 5 (FL10EX-D-H)

*3) : Transmittance is depend on spectrum of backlight.

*The information contained herein is presented only as a guide for the applications of our products. No responsibility is assumed by Toshiba Matsushita Display Technology or other rights of the third parties which may result from its use. No license is granted by implication or otherwise under any patent or patent rights of Toshiba Matsushita Display Technology or others.

*The information contained herein may be changed without prior notice. It is therefore advisable to contact Toshiba Matsushita Display Technology before proceeding with the design of equipment incorporating this product.

BLOCK DIAGRAM

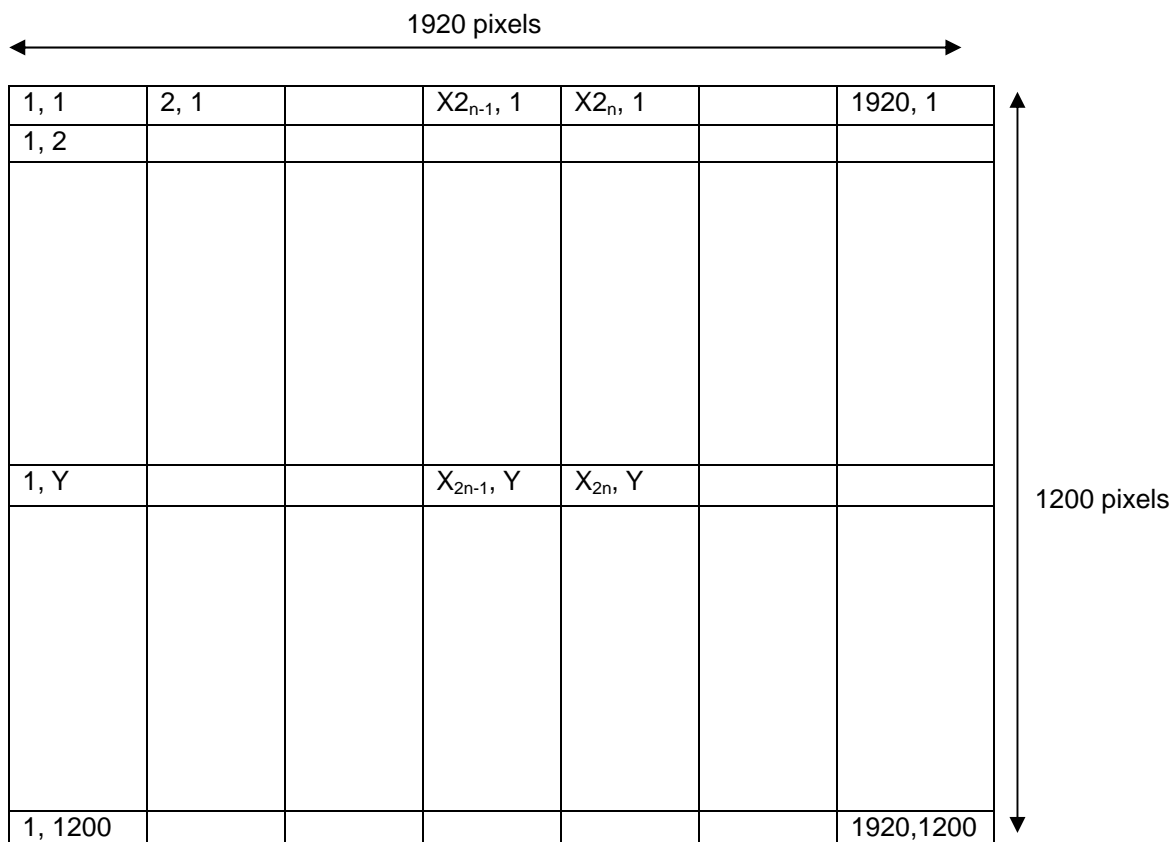
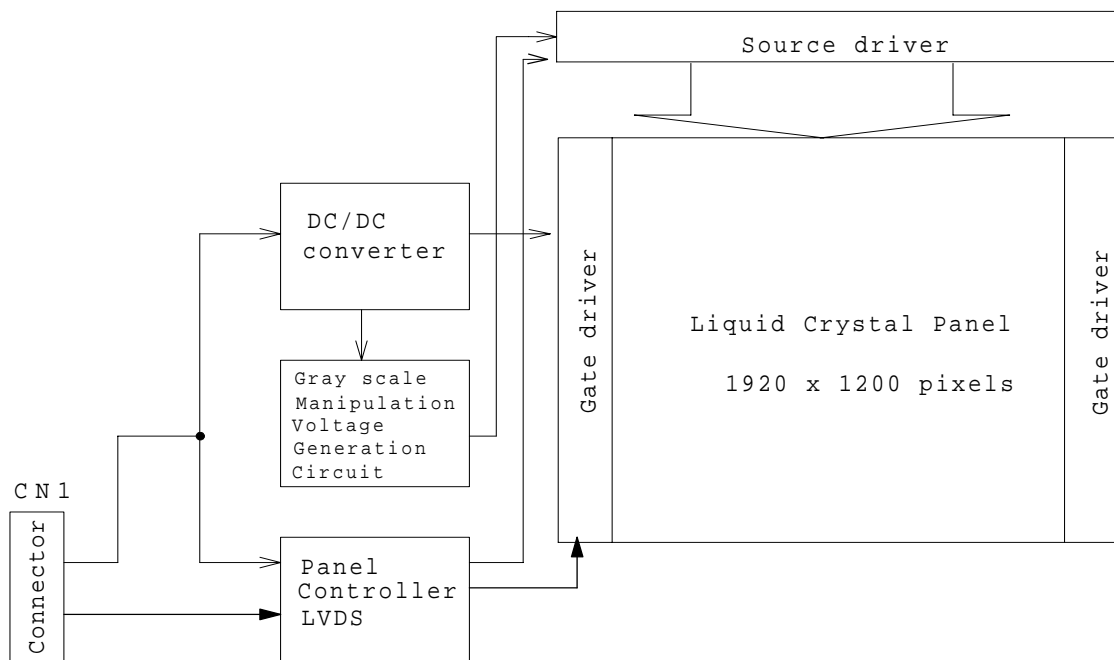

TIMING CHART(T.B.D)

(1) Vertical Timing

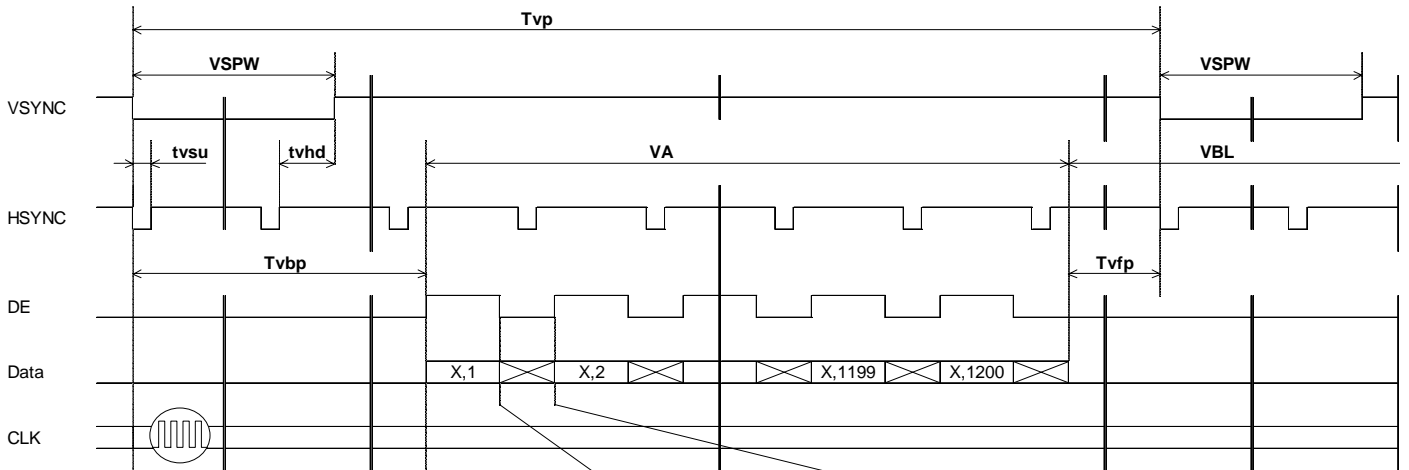

(2) Horizontal Timing

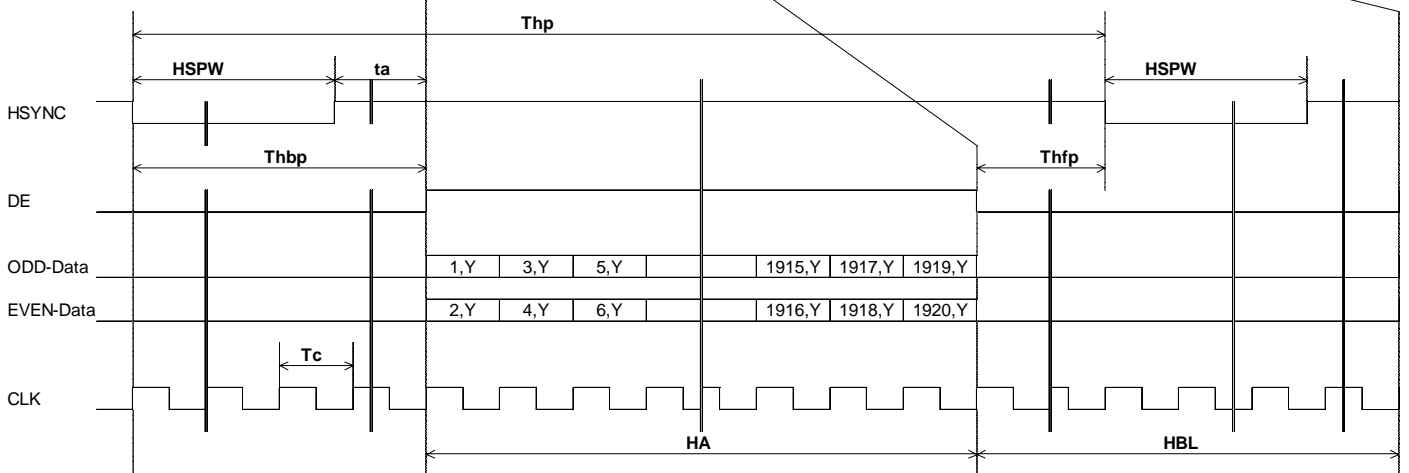

TIMING SPECIFICATION ^{1) 2) 3) 4) 5) 6) 7)}

Item	Symbol	min.	typ.	max.	unit
Horizontal Scanning Term	T_{hp}	-	1024	-	T_c
		-	13.50	-	us
H-sync Pulse Width ^{*8)}	HSPW	4	-	136	T_c
Horizontal Front Porch	t_{hfp}	4	-	136	T_c
Horizontal Back Porch ^{*8)}	T_{hbp}	16	-	-	T_c
Horizontal Sync Term	t_a	4	-	-	T_c
Horizontal Blanking Term	HBL	-	64	-	T_c
Horizontal Display Term	H_A	960	960	960	T_c
Frame Period	T_{vp}	-	1235	-	T_{hp}
		-	16.67	16.67	ms
V-sync Pulse Width	VSPW	1	-	-	T_{hp}
V-sync Set Up Time (to H-sync)	t_{vsu}	8	-	-	T_c
V-sync Hold Time	t_{vhd}	8	-	-	T_c
Vertical Front Porch	t_{vfp}	8	-	-	T_c
Vertical Back Porch ^{*8)}	T_{vbp}	4	-	-	T_c
Vertical Blanking Term	VBL	-	35	-	T_{hp}
Vertical Display Term	V_A	1200	1200	1200	T_{hp}
DE Pulse Width	H_A	960	960	960	T_c
Clock Period	T_c	13.179	13.179	-	ns

Note 1) Refer to "TIA/EIA Timing Chart"

Note 2) If ENAB is fixed to "H" or "L" level for certain period while NCLK is supplied, the panel displays black with some flicker.

Note 3) If NCLK is fixed to "H" or "L" level for certain period while ENAB is supplied, the panel may be damaged.

Note 4) Please adjust LCD operating signal timing and FL driving frequency, to optimize the display quality.

There is a possibility that flicker is observed by the interference of LCD operating signal timing and FL driving condition (especially driving frequency), even if the condition satisfies above timing specifications and recommended operating conditions shown in 3.

Note5) Do not make t_v , t_{vdh} and t_{vds} fluctuate.

If t_v , t_{vdh} , and t_{vds} are fluctuate, the panel displays black.

Note6) In case of using the long frame period, the deterioration of display quality, noise etc. may be occurred.

Note7) NCLK count of each Horizontal Scanning Time should be always the same.

V-Blanking period should be " n " X "Horizontal Scanning Time". (n : integer)

Frame period should be always the same.

Note 8) Please keep below equations.

$$VBL = T_{vfp} + T_{vbp}$$

$$HSPW = HBL - T_{hfp} - t_a$$

$$T_{hbp} = HSPW + t_a$$

CONNECTOR PIN ASSIGNMENT FOR INTERFACE

CN1 INPUT SIGNAL

Connector : FI-XB30SR-HF11(Locking Type) / JAPAN AVIATION ELECTRONICS INDUSTRY,LTD.

Mating Connector :

Wire Type:FI-X30H (Housing), FI-XC3-A-15000 (Contact)

FPC Type:FI-X30M or FI-X30M R, Coax Type:FI-X30C or FI-X30C2(Housing), FI-X30CH-7000(Shell)

Terminal No.	Symbol	Function
1	GND	Ground
2	VDD	Power Supply : +3.3V
3	VDD	Power Supply : +3.3V
4	NC	Non-Connection
5	NC	Non-Connection
6	NC	Non-Connection
7	NC	Non-Connection
8	RxOIN0-	Odd Negative LVDS differential data input (R0-R5,G0)
9	RxOIN0+	Odd Positive LVDS differential data input (R0-R5,G0)
10	GND	Ground
11	RxOIN1-	Odd Negative LVDS differential data input (G1-G5, B0-B1)
12	RxOIN1+	Odd Positive LVDS differential data input (G1-G5, B0-B1)
13	GND	Ground
14	RxOIN2-	Odd Negative LVDS differential data input (B2-B5, HS, VS, DE)
15	RxOIN2+	Odd Positive LVDS differential data input (B2-B5, HS, VS, DE)
16	GND	Ground
17	OCLK-	Odd Clock Signal(-)
18	OCLK+	Odd Clock Signal(+)
19	GND	Ground
20	RxEIN0-	Even Negative LVDS differential data input (R0-R5,G0)
21	RxEIN0+	Even Positive LVDS differential data input (R0-R5,G0)
22	GND	Ground
23	RxEIN1-	Even Negative LVDS differential data input (G1-G5, B0-B1)
24	RxEIN1+	Even Positive LVDS differential data input (G1-G5, B0-B1)
25	GND	Ground
26	RxEIN2-	Even Negative LVDS differential data input (B2-B5, HS, VS, DE)
27	RxEIN2+	Even Positive LVDS differential data input (B2-B5, HS, VS, DE)
28	GND	Ground
29	ECLK-	Even Clock Signal(-)
30	ECLK+	Even Clock Signal(+)

Note 1) Please connect GND pin to ground. Don't use it as no-connect nor connection with high impedance.

**RECOMMENDED TRANSMITTER (DS90CF365)
TO LTD154EZ0HG INTERFACE ASSIGNMENT**

Case1: 6bit Transmitter

(DS90CF365)				LTD154EZ0HG Interface (CN1)		
Input Terminal No.		Input Signal (Graphics controller output signal)		Output Signal Symbol	Terminal	Symbol
Symbol	Terminal	Symbol	Function			
TA0	44	R0	Red Pixels Display Data (LSB)	TA- TA+	No.5 No.6	RxIN0- RxIN0+
TA1	45	R1	Red Pixels Display Data			
TA2	47	R2	Red Pixels Display Data			
TA3	48	R3	Red Pixels Display Data			
TA4	1	R4	Red Pixels Display Data			
TA5	3	R5	Red Pixels Display Data (MSB)			
TA6	4	G0	Green Pixels Display Data (LSB)			
TB0	6	G1	Green Pixels Display Data	TB- TB+	No.8 No.9	RxIN1- RxIN1+
TB1	7	G2	Green Pixels Display Data			
TB2	9	G3	Green Pixels Display Data			
TB3	10	G4	Green Pixels Display Data			
TB4	12	G5	Green Pixels Display Data (MSB)			
TB5	13	B0	Blue Pixels Display Data (LSB)			
TB6	15	B1	Blue Pixels Display Data			
TC0	16	B2	Blue Pixels Display Data	TC- TC+	No.11 No.12	RxIN2- RxIN2+
TC1	18	B3	Blue Pixels Display Data			
TC2	19	B4	Blue Pixels Display Data			
TC3	20	B5	Blue Pixels Display Data (MSB)			
TC4	22	HSYNC	Horizontal Synchronization Signal			
TC5	23	VSYNC	Vertical Synchronization Signal			
TC6	25	DE	Compound Synchronization Signal			
CLK IN	26	CLK	Data Sampling Clock	TCLK- TCLK+	No.14 No.15	CLK- CLK+

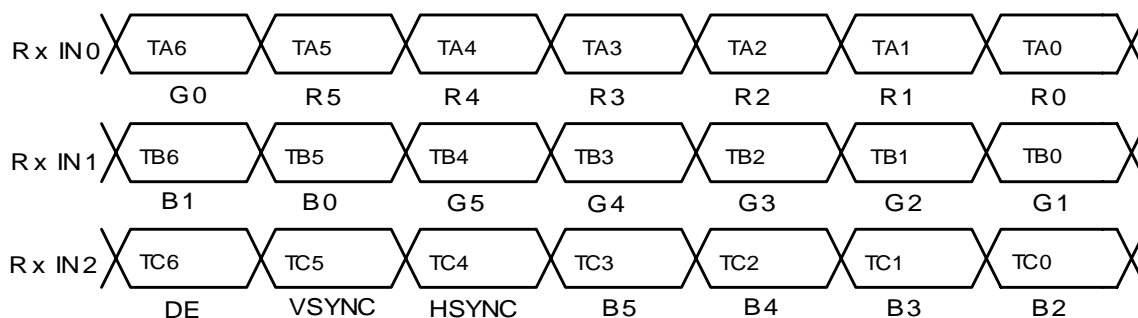

256k (k=1024) COLORS COMBINATION TABLE

	Display	R5 R4 R3 R2 R1 R0	G5 G4 G3 G2 G1 G0	B5 B4 B3 B2 B1 B0	Gray Scale Level
Basic Color	Black	L L L L L L L	L L L L L L L	L L L L L L L	-
	Blue	L L L L L L L	L L L L L L L	H H H H H H H	-
	Green	L L L L L L L	H H H H H H H	L L L L L L L	-
	Light Blue	L L L L L L L	H H H H H H H	H H H H H H H	-
	Red	H H H H H H H	L L L L L L L	L L L L L L L	-
	Purple	H H H H H H H	L L L L L L L	H H H H H H H	-
	Yellow	H H H H H H H	H H H H H H H	L L L L L L L	-
	White	H H H H H H H	H H H H H H H	H H H H H H H	-
Gray Scale of Red	Black	L L L L L L L	L L L L L L L	L L L L L L L	L 0
	Dark ↑ ↓ Light	L L L L L L H	L L L L L L L	L L L L L L L	L 1
		L L L L L H L	L L L L L L L	L L L L L L L	L 2
		: :	: :	: :	L3...
		: :	: :	: :	L60
		H H H H L H	L L L L L L L	L L L L L L L	L61
	H H H H H L	L L L L L L L	L L L L L L L	L62	
	Red	H H H H H H H	L L L L L L L	L L L L L L L	Red L63
Gray Scale of Green	Black	L L L L L L L	L L L L L L L	L L L L L L L	L 0
	Dark ↑ ↓ Light	L L L L L L L	L L L L L L H	L L L L L L L	L 1
		L L L L L L L	L L L L L H L	L L L L L L L	L 2
		: :	: :	: :	L3...
		: :	: :	: :	L60
		L L L L L L L	H H H H L H	L L L L L L L	L61
	L L L L L L L	H H H H H L	L L L L L L L	L62	
	Green	L L L L L L L	H H H H H H H	L L L L L L L	Green L63
Gray Scale of Blue	Black	L L L L L L L	L L L L L L L	L L L L L L L	L 0
	Dark ↑ ↓ Light	L L L L L L L	L L L L L L L	L L L L L L H	L 1
		L L L L L L L	L L L L L L L	L L L L H L	L 2
		: :	: :	: :	L3...
		: :	: :	: :	L60
		L L L L L L L	L L L L L L L	H H H H L H	L61
	L L L L L L L	L L L L L L L	H H H H H L	L62	
	Blue	L L L L L L L	L L L L L L L	H H H H H H H	Blue L63
Gray Scale of White & Black	Black	L L L L L L L	L L L L L L L	L L L L L L L	L 0
	Dark ↑ ↓ Light	L L L L L L H	L L L L L L H	L L L L L L H	L 1
		L L L L H L	L L L L H L	L L L L H L	L 2
		: :	: :	: :	L3...
		: :	: :	: :	L60
		H H H H L H	H H H H L H	H H H H L H	L61
	H H H H H L	H H H H H L	H H H H H L	L62	
	White	H H H H H H H	H H H H H H H	H H H H H H H	White L63