



VD사업부

Ver._____

승인서

SEC CODE	
품명 (Description)	LCD-Panel
규격 (Specification)	32inch, CCFL, 60Hz, HD
Maker P/N	
적용기종 (적용모델)	
특기사항	

기안 (DRAWING)	심사 (CHECK)	합의 (AGREEMENT)	승인 (APPROVAL)
2010. .	2010. .	2010. .	2010. .
승인기간	승인일로부터		

Maker	삼성전자 LCD사업부	Tel.	041-535-1244
ADDRESS	336-841 충남 아산시 탕정면 명암리 200번지		
URL	http://www.samsung.com		

MODEL	LTF320AP11	Doc. No	07-000-S-101119	Page	1/29
--------------	-------------------	----------------	------------------------	-------------	-------------



Approval

Customer :Visual Display Division DATE :19.Nov. 2010

SAMSUNG TFT-LCD

MODEL : LTF320AP11(BN07-00978A)

Any Modification of Specification is not allowed without SEC's Permission.

NOTE :

Customer's Approval	
SIGNATURE	DATE

APPROVAED BY <i>Heo Jeongmin</i>	DATE 19.Nov. 2010
PREPARED BY Bong U Lee	DATE 19.Nov. 2010

LCD Business

Samsung Electronics Co . , LTD.

MODEL	LTF320AP11	Doc. No	07-000-S-101119	Page	2/29
-------	------------	---------	-----------------	------	------



Revision History

Date	Rev. No	Page	Summary
19.Nov. 2010	000	all	First issued

www.panelook.com

MODEL

LTF320AP11

Doc. No

07-000-S-101119

Page

3/29

Contents

General Description	(5)
1. Absolute Maximum Ratings	(6)
2. Optical Characteristics	(7)
3. Electrical Characteristics	(10)
3.1 TFT LCD Module	
3.2 Back Light Unit	
3.3 T-board Input Condition & Specification	
3.4 T- Board Pin map	
4. Block Diagram	(14)
4.1 TFT LCD Module	
5. Input Terminal Pin Assignment	(15)
5.1 Input Signal & Power	
5.2 LVDS Interface	
5.3 Input Signals, Basic Display Colors and Gray Scale of Each Color	
6. Interface Timing	(19)
6.1 Timing Parameters (DE only mode)	
6.2 Timing Diagrams of interface Signal (DE only mode)	
6.3 Power ON/OFF Sequence	
7. Outline Dimension	(22)
8. Reliability Test	(24)
9. Packing	(25)
10. Marking & Others	(26)
11. General Precaution	(27)
11.1 Handling	
11.2 Storage	
11.3 Operation	
11.4 Others	

MODEL

LTF320AP11

Doc. No

07-000-S-101119

Page

4/29

General Description

Description

LTF320AP11 is a color active matrix liquid crystal display (LCD) that uses amorphous silicon TFT (Thin Film Transistor) as switching components. This model is composed of a TFT LCD panel, a driver circuit and a back light unit. The resolution of a 32.0" is 1366 x 768 and this model can display up to 16.7 million colors with wide viewing angle of 89° or higher in all directions. This panel is intended to support applications to provide an excellent performance for Flat Panel Display such as Home-alone Multimedia TFT-LCD TV and High Definition TV.

Features

- RoHS compliance (Pb-free)
- High contrast & aperture ratio with wide color gamut
- PVA (Patterned Vertical Align) mode
- Wide viewing angle ($\pm 178^\circ$)
- High speed response
- HD resolution (16:9)
- Low Power consumption
- U-Type 4 CCFLs (Cold Cathode Fluorescent Lamp)
- Sync Format: DE (Data Enable) mode
- LVDS (Low Voltage Differential Signaling) interface (1pixel/clock)

General Information

Items	Specification	Unit	Note
Module Size	760.0(H _{TYP}) x 450.0(V _{TYP})	mm	± 1.0 mm
	54.2 (D _{MAX})		With T-board
Weight	5,500 (max)	g	With T-board
Pixel Pitch	0.51075(H) x 0.17025(V)	mm	
Active Display Area	697.6845(H) x 392.256(V)	mm	
Surface Treatment	Haze 2.2%, Hard-Coating (2H)	-	
Display Colors	8 bit , 16.7M	colors	
Number of Pixels	1366 x 768	pixel	
Pixel Arrangement	RGB Horizontal stripe	-	
Display Mode	Normally Black	-	
Luminance of White	400 (Typ.)	cd/m ²	

MODEL

LTF320AP11

Doc. No

07-000-S-101119

Page

5/29

1. Absolute Maximum Ratings

If the condition exceeds maximum ratings, it can cause malfunction or unrecoverable damage to the device.

(VSS = 0 V)

Item	Symbol	Min.	Max.	Unit	Note
Power Supply Voltage	V_{DD}	10.8	13.2	V	(1)
Storage temperature	T_{STG}	-20	65	°C	(2)
Center of Glass Surface temperature (Operation)	T_{SUR}	0	65	°C	(2)
Operation temperature	T_{OPR}	0	50	°C	(2)
Shock (non - operating)	S_{nop}	-	50	G	(3)
Vibration (non - operating)	V_{nop}	-	1.5	G	(4)

Note (1) $T_a = 25 \pm 2$ °C

(2) Temperature and relative humidity range are shown in the figure below.

a. 90 % RH Max. ($T_a \leq 39$ °C)

b. Relative Humidity is 90% or less. ($T_a > 39$ °C)

c. No condensation

(3) 11ms, sine wave, one time for $\pm X$, $\pm Y$, $\pm Z$ axis

(4) 10-300 Hz, Sweep rate 10min, 30min for X,Y,Z axis

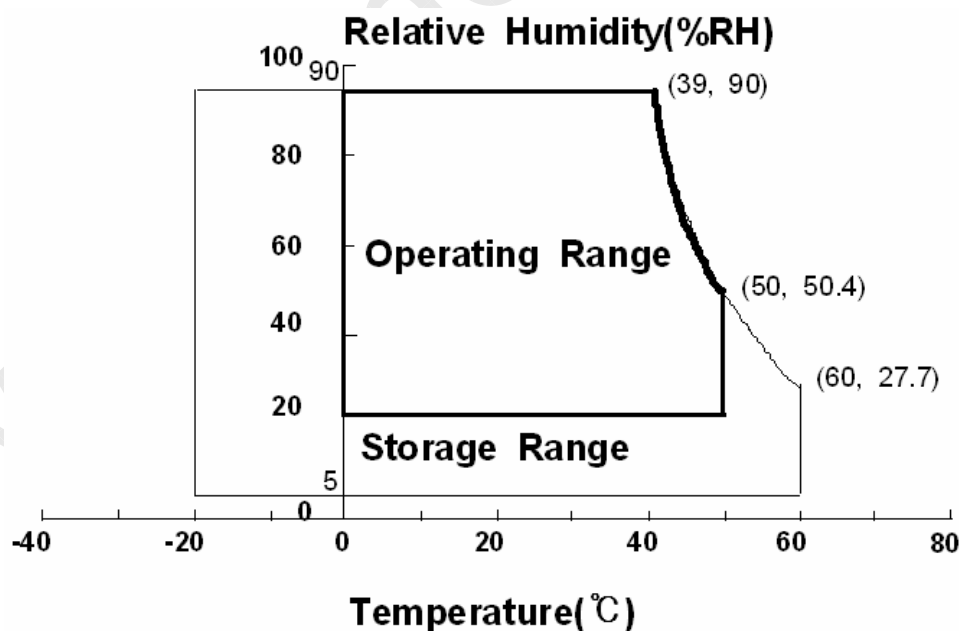

Fig. Temperature and Relative humidity range

MODEL

LTF320AP11

Doc. No

07-000-S-101119

Page

6/29

2. Optical Characteristics

The optical characteristics should be measured in a dark room or equivalent.

Measuring equipment : TOPCON RD-80S, TOPCON SR-3, ELDIM EZ-Contrast

(Ta = 25 ± 2°C, VDD=12V, fv= 60 Hz, f_{DCLK}=78 MHz, Inverter=62.5KHz, Duty 100%)

Item		Symbol	Condition	Min.	Typ.	Max.	Unit	Note
Contrast Ratio (Center of screen)		C/R	Normal $\theta_{L,R}=0$ $\theta_{U,D}=0$	3500	4000	-		(1) SR-3
Response Time	G-to-G (Avg)	Tg		-	8	16	msec	(3) RD-80S
Luminance of White (Center of screen)		Y _L		350	400	-	cd/m ²	(4) SR-3
Color Chromaticity (CIE 1931)	Red	Rx	Viewing Angle	TYP. -0.03	0.640	TYP. +0.03		(5),(6) SR-3
		Ry			0.340			
	Green	Gx			0.300			
		Gy			0.600			
	Blue	Bx			0.150			
		By			0.060			
	White	Wx			0.280			
		Wy			0.290			
Color Gamut		-	-	72	-	%	(5) SR-3	
Color Temperature		-	-	10,000	-	K	(5) SR-3	
Viewing Angle	Hor.	θ_L	C/R ≥ 10	79	89	-	Degree	(6) EZ-Contrast
		θ_R		79	89	-		
	Ver.	θ_U		79	89	-		
		θ_D		79	89	-		
Brightness Uniformity (9 Points)		B _{uni}	-	-	25	%	(2) SR-3	

- Test Equipment Setup

The measurement should be executed in a stable, windless and dark room between 40min and 60min after lighting the back light at 25 ± 2°C for stabilization of the back light. This should be measured in the center of screen.

Single lamp current : Max

Environment condition : Ta = 25 ± 2 °C

MODEL

LTF320AP11

Doc. No

07-000-S-101119

Page

7/29

Photo detector	Field
SR-3	1°
RD-80S	2°

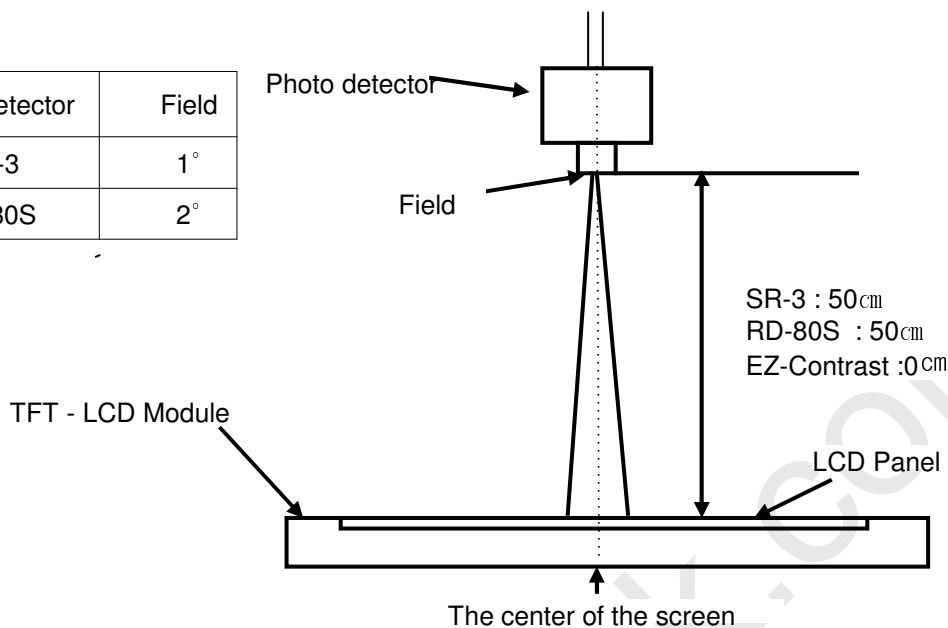

- Definition of test point

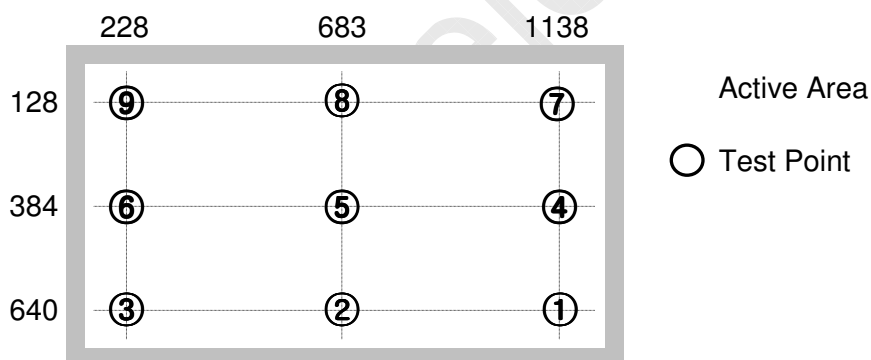

Note (1) Definition of Contrast Ratio (C/R)

: Ratio of gray max (Gmax) & gray min (Gmin) at the center point ⑤ of the panel

$$C/R = \frac{G_{max}}{G_{min}}$$

Gmax : Luminance with all pixels white

Gmin : Luminance with all pixels black

MODEL	LTF320AP11	Doc. No	07-000-S-101119	Page	8/29
-------	------------	---------	-----------------	------	------

Note (2) Definition of 9 points brightness uniformity (Test pattern : Full White)

$$B_{uni} = 100 * \frac{(B_{max} - B_{min})}{B_{max}}$$

Bmax : Maximum brightness

Bmin : Minimum brightness

Note (3) Definition of Response time : Sum of Tr, Tf

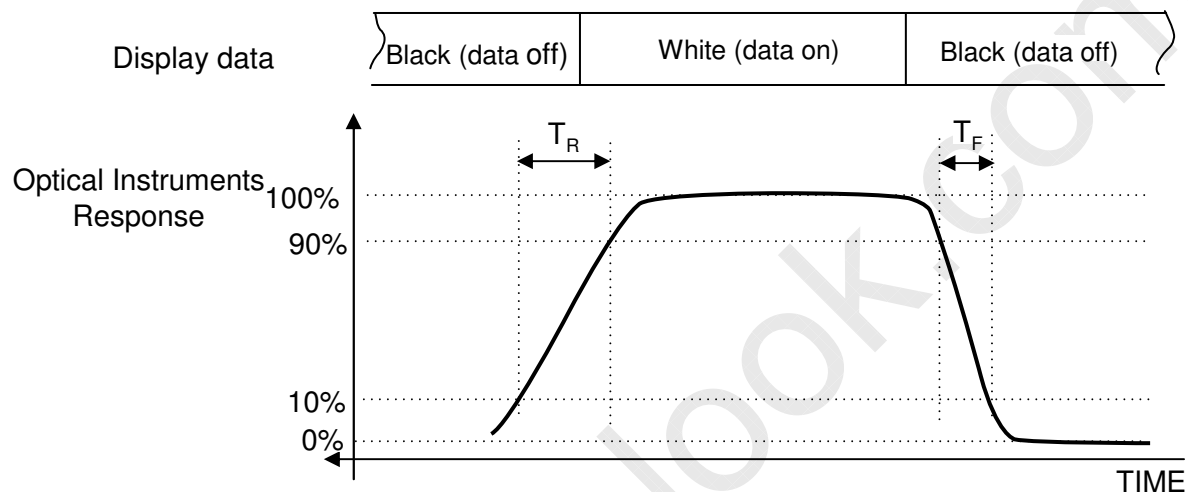

※ G-to-G : Average response time between Gray to gray (scale)

Note (4) Definition of Luminance of White : Luminance of white at center point ⑤

Note (5) Definition of Color Chromaticity (CIE 1931)

Color coordinate of Red, Green, Blue & White at center point ⑤

Note (6) Definition of Viewing Angle

: Viewing angle range ($C/R \geq 10$)

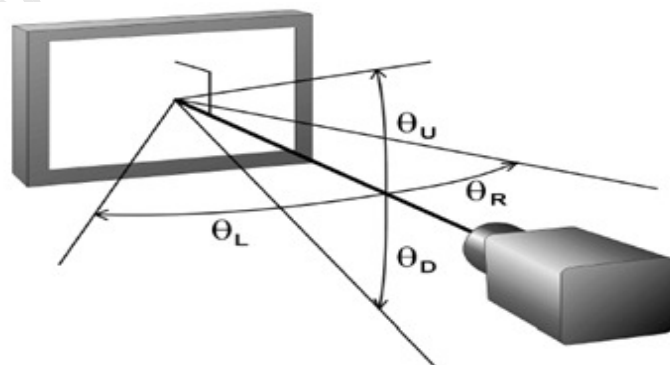

MODEL

LTF320AP11

Doc. No

07-000-S-101119

Page

9/29

3. Electrical Characteristics

3.1 TFT LCD Module

The connector for display data & timing signal should be connected.

$T_a = 25^{\circ}\text{C} \pm 2^{\circ}\text{C}$

Item	Symbol	Min.	Typ.	Max.	Unit	Note
Voltage of Power Supply	V_{DD}	10.8	12.0	13.2	V	(1)
Current of Power Supply	(a) Black	250	450	650	mA	(2),(3)
	(b) White	250	450	650	mA	
	(c) V-Stripe	500	700	900	mA	
Vsync Frequency	f_V	48	60	66	Hz	
Hsync Frequency	f_H	44	48	53	kHz	
Main Frequency	f_{DCLK}	72	78	85	MHz	
Rush Current	I_{RUSH}	-	-	4	A	(4)

Note (1) The ripple voltage should be controlled under 10% of V_{DD} .

(2) $f_V = 60\text{ Hz}$, $f_{DCLK} = 78\text{ MHz}$, $V_{DD} = 12.0\text{V}$, DC Current.

(3) Power dissipation check pattern (LCD Module only)

a) Black Pattern b) White Pattern c) V-Stripe

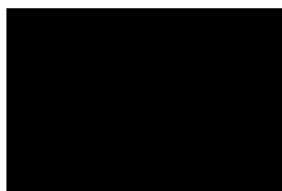

(4) Measurement Conditions

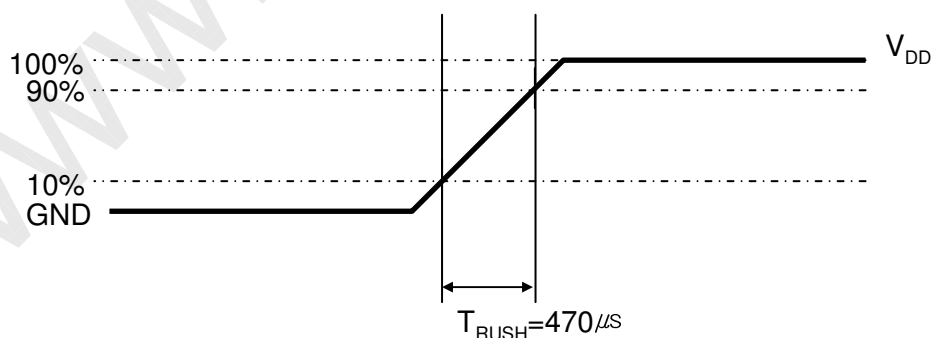

Rush Current I_{RUSH} can be measured when T_{RUSH} is $470\mu\text{s}$.

MODEL

LTF320AP11

Doc. No

07-000-S-101119

Page

10/29

3.2 Back Light Unit

The back light unit consists of 4 U-type CCFLs (Cold Cathode Fluorescent Lamp).

$T_a = 25 \pm 2^\circ\text{C}$

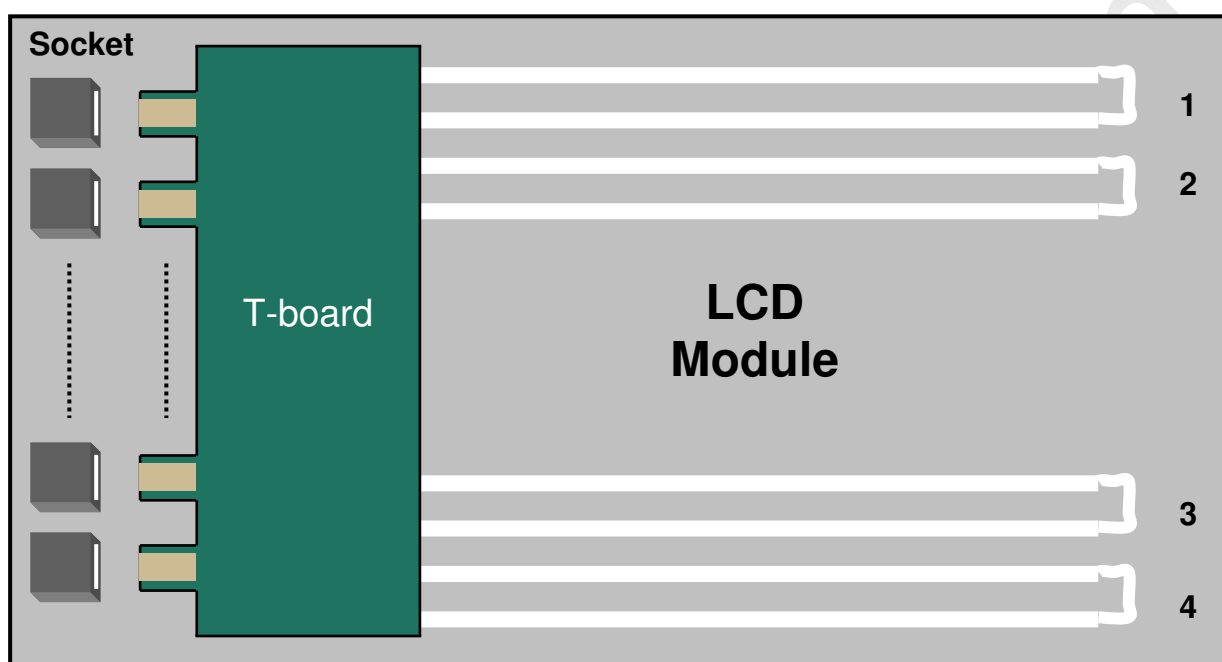

Item	Symbol	Min.	Typ.	Max.	Unit	Note
Operating Life Time	Hr	-	50000	-	Hour	(1)

Note (1) It is defined as the time to take until the brightness reduces to 50% of its original value.

[Operating condition : $T_a = 25 \pm 2^\circ\text{C}$, For single lamp only.]

3.3 T-board Input Condition & Specification

ITEM	SYMBOL	MIN	TYP	MAX	Note	UNIT	Remark
Input Voltage	HIGH (FET)	380	390	400		Vrms	PFC Voltage (rms)
	LOW (FET)	190	195	200			
Output Current	Io (I_MAX)	11.3	12	12.7	(1)	mArms	DIM=100%
	Duty (I_MIN)	-	20	-	(2)	%	IP B'rd Output
Switching Frequency	fop	61.5	63	64.5		kHz	Switching Frequency
Dimming Frequency	fpwm	-	150	-		Hz	IP B'rd Output
Open Lamp Voltage	V _{OPEN} (All Lamp is NC)	2510	-	-	(3)	Vrms	

Note1) Output Current Test Condition : After running 1 hour.

Note2) Dim Duty

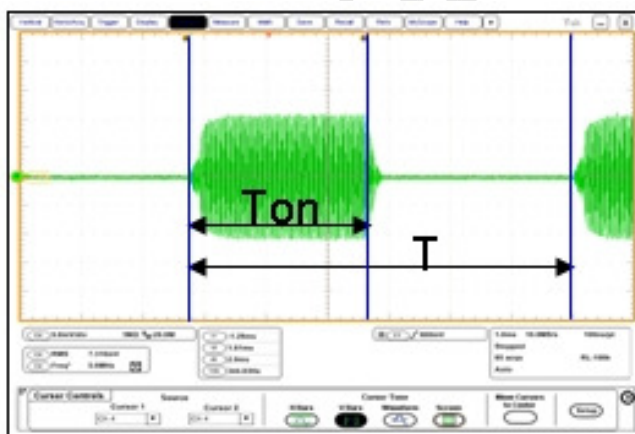

$$\text{Duty (\%)} = \frac{T_{\text{on}}}{T} \times 100$$

Note3) Open Voltage Measure Method

: Check Vopen on the Backlight that all lamp is removed.

MODEL

LTF320AP11

Doc. No

07-000-S-101119

Page

12/29

3.4 T- Board Pin map

1) CN1 CONNECTOR : 20037WR-H12 (YEONHO)

Pin NO	SYMBOL	REMARK
1	HIGH (FET)	Switching Pulse (390V, Primary)
2	NC	
3	LOW (FET)	Blocking cap. (195Vdc, Primary)
4	NC	
5	NC	
6	NC	
7	NC	
8	GND	Ground (Secondary)
9	OVP	Over Voltage Protection
10	CNT_PRT	Open Connector Protection (Normal 12V, Active Low)
11	VCC	Power Supply for Protection Circuit (Typical 12V)
12	LD	Lamp Detection (Active Low)

MODEL

LTF320AP11

Doc. No

07-000-S-101119

Page

13/29

4. BLOCK DIAGRAM

4.1 TFT LCD Module

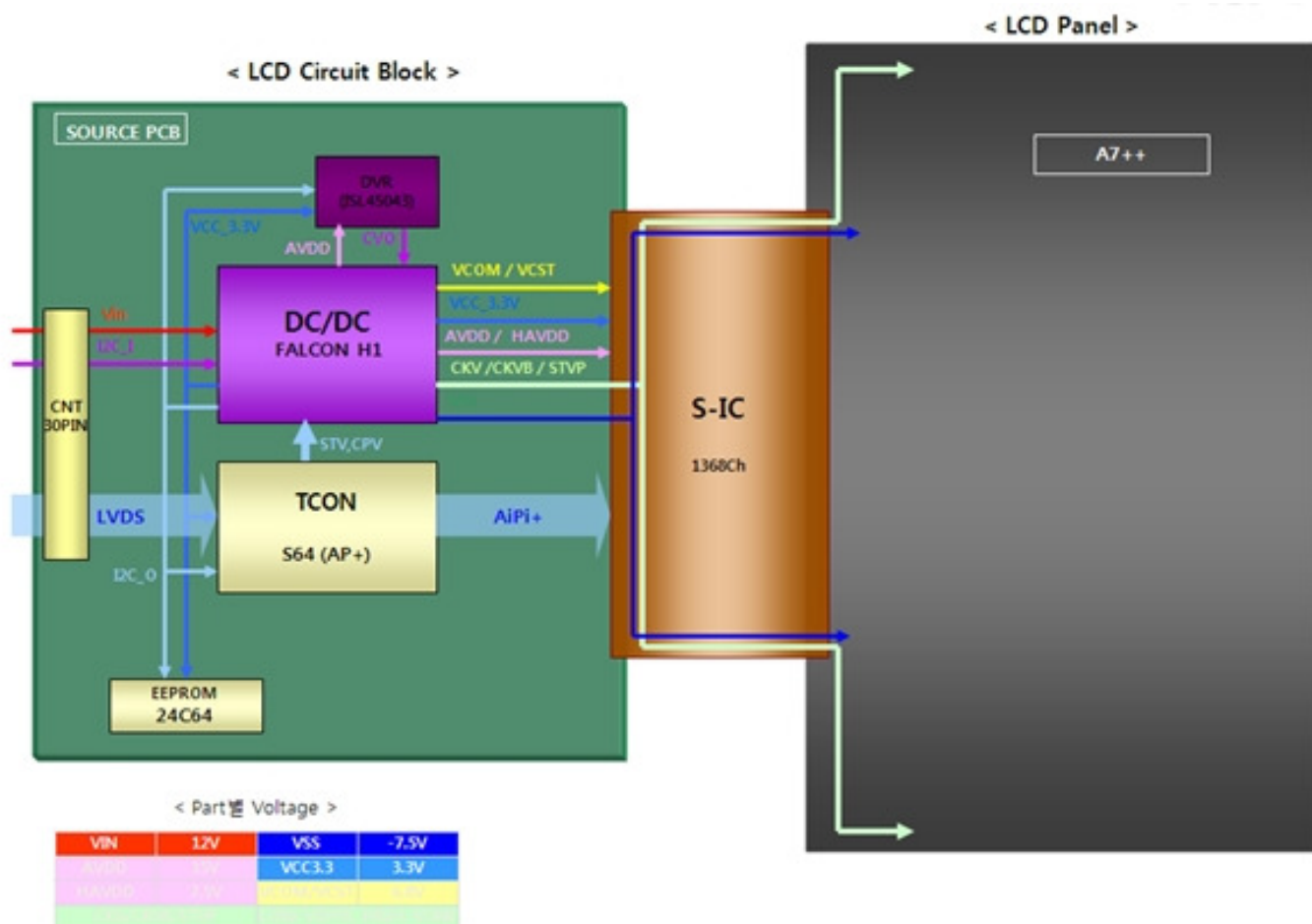

MODEL

LTF320AP11

Doc. No

07-000-S-101119

Page

14/29

5. Input Circuit Pin Assignment

5.1. Input Signal

Connector : P-TWO

PIN No.	Description	PIN No.	Description
1	N.C	16	GND
2	N.C	17	LV3_N_I
3	N.C	18	LV3_P_I
4	GND	19	GND
5	LV0_N_I	20	NC
6	LV0_P_I	21	JEIDA/NORMAL
7	GND	22	WPN
8	LV1_N_I	23	NC
9	LV1_P_I	24	NC
10	GND	25	GND
11	LV2_N_I	26	12V
12	LV2_P_I	27	
13	GND	28	
14	LVCLK_N_I	29	
15	LVCLK_P_I	30	

Note1) No Connection: This PINS are only used for SAMSUNG internal using.

Note2) LVDS OPTION : If this PIN is HIGH (3.3 V) → Normal LVDS format
 LOW (GND) → JEIDA LVDS format

SEQUENCE : On = V_{DD}(T1) → LVDS Option → Interface Signal(T2)

OFF = Interface Signal(T3) → LVDS Option → V_{DD}

MODEL

LTF320AP11

Doc. No

07-000-S-101119

Page

15/29

Note(1) Pin number starts from Left side

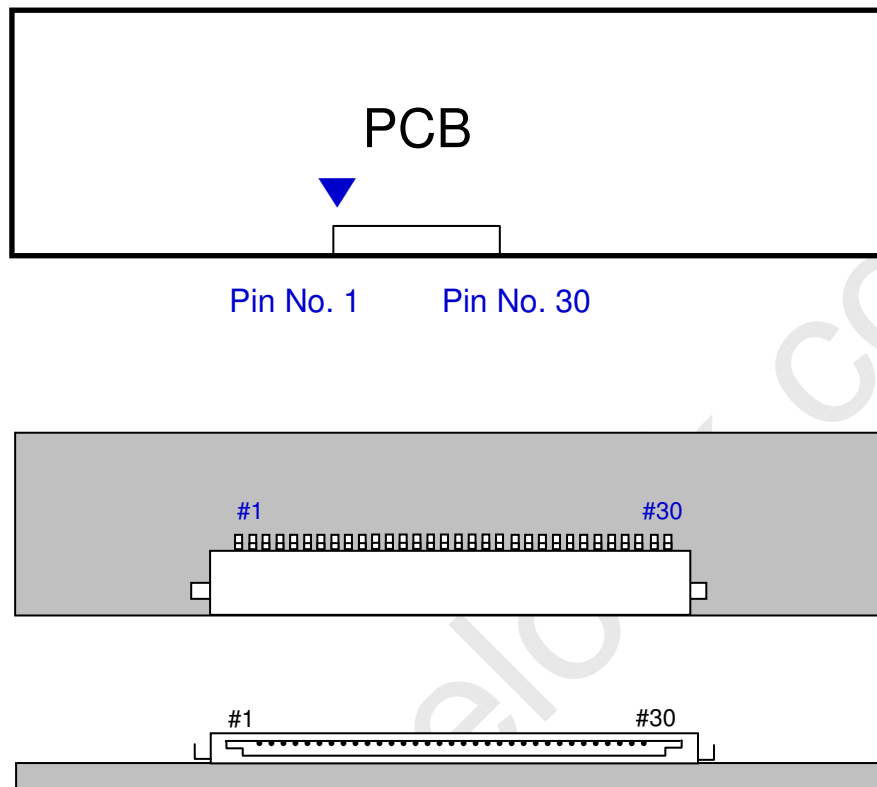

Fig. Connector diagram

- a. Power GND pins should be connected to the LCD's metal chassis.
- b. All power input pins should be connected together.
- c. All NC pin should be separated from other signal or power.

5.2 LVDS Interface

- LVDS Receiver : Tcon (merged)
- Data Format (JEIDA & Normal)

	LVDS pin	JEIDA -DATA	VESA -DATA
TxOUT/RxIN0	TxIN/RxOUT0	R2	R0
	TxIN/RxOUT1	R3	R1
	TxIN/RxOUT2	R4	R2
	TxIN/RxOUT3	R5	R3
	TxIN/RxOUT4	R6	R4
	TxIN/RxOUT6	R7	R5
	TxIN/RxOUT7	G2	G0
TxOUT/RxIN1	TxIN/RxOUT8	G3	G1
	TxIN/RxOUT9	G4	G2
	TxIN/RxOUT12	G5	G3
	TxIN/RxOUT13	G6	G4
	TxIN/RxOUT14	G7	G5
	TxIN/RxOUT15	B2	B0
	TxIN/RxOUT18	B3	B1
TxOUT/RxIN2	TxIN/RxOUT19	B4	B2
	TxIN/RxOUT20	B5	B3
	TxIN/RxOUT21	B6	B4
	TxIN/RxOUT22	B7	B5
	TxIN/RxOUT24	HSYNC	HSYNC
	TxIN/RxOUT25	VSYNC	VSYNC
	TxIN/RxOUT26	DEN	DEN
TxOUT/RxIN3	TxIN/RxOUT27	R0	R6
	TxIN/RxOUT5	R1	R7
	TxIN/RxOUT10	G0	G6
	TxIN/RxOUT11	G1	G7
	TxIN/RxOUT16	B0	B6
	TxIN/RxOUT17	B1	B7
	TxIN/RxOUT23	RESERVED	RESERVED

MODEL

LTF320AP11

Doc. No

07-000-S-101119

Page

17/29

5.3 Input Signals, Basic Display Colors and Gray Scale of Each Color

COLOR	DISPLAY (8bit)	DATA SIGNAL																								GRAY SCALE LEVEL
		RED							GREEN							BLUE										
		R0	R1	R2	R3	R4	R5	R6	R7	G0	G1	G2	G3	G4	G5	G6	G7	B0	B1	B2	B3	B4	B5	B6	B7	
BASIC COLOR	BLACK	0	0	0	0	0	0	0	0	0	0	0	0	0	0	0	0	0	0	0	0	0	0	0	0	-
	BLUE	0	0	0	0	0	0	0	0	0	0	0	0	0	0	0	0	1	1	1	1	1	1	1	1	-
	GREEN	0	0	0	0	0	0	0	0	1	1	1	1	1	1	1	1	0	0	0	0	0	0	0	0	-
	CYAN	0	0	0	0	0	0	0	0	1	1	1	1	1	1	1	1	1	1	1	1	1	1	1	1	-
	RED	1	1	1	1	1	1	1	1	0	0	0	0	0	0	0	0	0	0	0	0	0	0	0	0	-
	MAGENTA	1	1	1	1	1	1	1	1	0	0	0	0	0	0	0	0	1	1	1	1	1	1	1	1	-
	YELLOW	1	1	1	1	1	1	1	1	1	1	1	1	1	1	1	1	0	0	0	0	0	0	0	0	-
	WHITE	1	1	1	1	1	1	1	1	1	1	1	1	1	1	1	1	1	1	1	1	1	1	1	1	-
GRAY SCALE OF RED	BLACK	0	0	0	0	0	0	0	0	0	0	0	0	0	0	0	0	0	0	0	0	0	0	0	R0	
	DARK ↑	1	0	0	0	0	0	0	0	0	0	0	0	0	0	0	0	0	0	0	0	0	0	0	R1	
		0	1	0	0	0	0	0	0	0	0	0	0	0	0	0	0	0	0	0	0	0	0	0	R2	
		:	:	:	:	:	:	:	:	:	:	:	:	:	:	:	:	:	:	:	:	:	:	:	R3~R252	
		:	:	:	:	:	:	:	:	:	:	:	:	:	:	:	:	:	:	:	:	:	:	:		
	↓ LIGHT	1	0	1	1	1	1	1	1	0	0	0	0	0	0	0	0	0	0	0	0	0	0	0	R253	
		0	1	1	1	1	1	1	1	0	0	0	0	0	0	0	0	0	0	0	0	0	0	0	R254	
	RED	1	1	1	1	1	1	1	1	0	0	0	0	0	0	0	0	0	0	0	0	0	0	0	R255	
GRAY SCALE OF GREEN	BLACK	0	0	0	0	0	0	0	0	0	0	0	0	0	0	0	0	0	0	0	0	0	0	0	G0	
	DARK ↑	0	0	0	0	0	0	0	0	1	0	0	0	0	0	0	0	0	0	0	0	0	0	0	G1	
		0	0	0	0	0	0	0	0	0	1	0	0	0	0	0	0	0	0	0	0	0	0	0	G2	
		:	:	:	:	:	:	:	:	:	:	:	:	:	:	:	:	:	:	:	:	:	:	:	G3~G252	
		:	:	:	:	:	:	:	:	:	:	:	:	:	:	:	:	:	:	:	:	:	:	:		
	↓ LIGHT	0	0	0	0	0	0	0	0	1	0	1	1	1	1	1	1	0	0	0	0	0	0	0	G253	
		0	0	0	0	0	0	0	0	0	1	1	1	1	1	1	1	0	0	0	0	0	0	0	G254	
	GREEN	0	0	0	0	0	0	0	0	1	1	1	1	1	1	1	1	0	0	0	0	0	0	0	G255	
GRAY SCALE OF BLUE	BLACK	0	0	0	0	0	0	0	0	0	0	0	0	0	0	0	0	0	0	0	0	0	0	0	B0	
	DARK ↑	0	0	0	0	0	0	0	0	0	0	0	0	0	0	0	0	1	0	0	0	0	0	0	B1	
		0	0	0	0	0	0	0	0	0	0	0	0	0	0	0	0	0	1	0	0	0	0	0	B2	
		:	:	:	:	:	:	:	:	:	:	:	:	:	:	:	:	:	:	:	:	:	:	:	B3~B252	
		:	:	:	:	:	:	:	:	:	:	:	:	:	:	:	:	:	:	:	:	:	:	:		
	↓ LIGHT	0	0	0	0	0	0	0	0	0	0	0	0	0	0	0	0	1	0	1	1	1	1	1	B253	
		0	0	0	0	0	0	0	0	0	0	0	0	0	0	0	0	0	1	1	1	1	1	1	B254	
	BLUE	0	0	0	0	0	0	0	0	0	0	0	0	0	0	0	0	1	1	1	1	1	1	1	B255	

Note) Definition of Gray :
 Rn : Red Gray, Gn : Green Gray, Bn : Blue Gray (n = Gray level)
 Input Signal : 0 = Low level voltage, 1 = High level voltage

MODEL	LTF320AP11	Doc. No	07-000-S-101119	Page	18/29
-------	------------	---------	-----------------	------	-------

6. Interface Timing

6.1 Timing Parameters (DE only mode)

SIGNAL	ITEM	SYMBOL	MIN.	TYP.	MAX.	Unit	NOTE
Clock	Frequency	$1/T_C$	72	78	85	MHz	-
Hsync		F_H	44	48	53	KHz	-
Vsync		F_V	48	60	66	Hz	-
Vertical Display Term	Active Display Period	T_{VD}	-	768	-	Lines	-
	Vertical Total	T_V	776	802	1200	Lines	-
Horizontal Display Term	Active Display Period	T_{HD}	-	1366	-	Clocks	-
	Horizontal Total	T_H	1464	1624	2000	clocks	-

Note) This product is DE only mode. The input of Hsync & Vsync signal does not have an effect on normal operation.

- (1) Test Point : TTL control signal and CLK at LVDS Tx input terminal in system
- (2) Internal $V_{DD} = 3.3V$

6.2 Timing diagrams of interface signal (DE only mode)

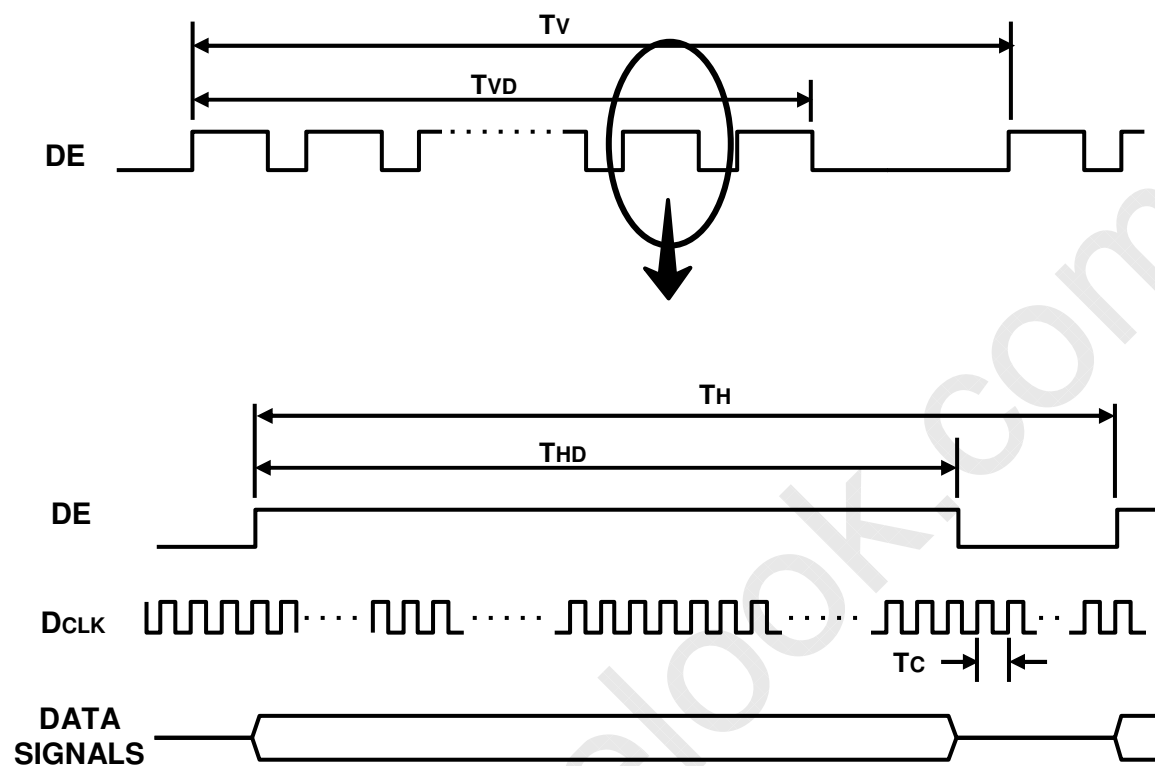

6.3 Power ON/OFF Sequence

To prevent a latch-up or DC operation of the LCD Module, the power on/off sequence should be as the diagram below.

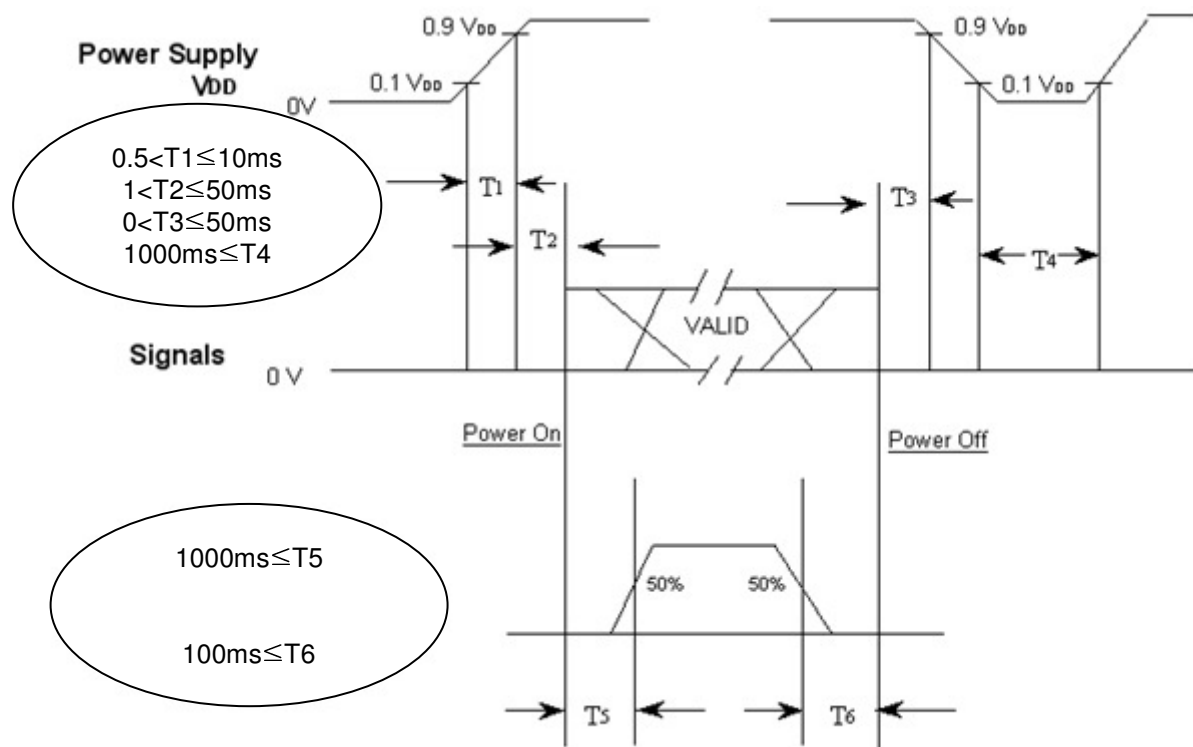

T_1 : V_{DD} rising time from 10% to 90%

T_2 : The time from V_{DD} to valid data at power ON.

T_3 : The time from valid data off to V_{DD} off at power Off.

T_4 : V_{DD} off time for Windows restart

T_5 : The time from valid data to B/L enable at power ON.

T_6 : The time from valid data off to B/L disable at power Off.

- The supply voltage of the external system for the Module input should be the same as the definition of V_{DD} .
- Apply the lamp voltage within the LCD operation range. When the back light turns on before the LCD operation or the LCD turns off before the back light turns off, the display may momentarily show abnormal screen.
- In case of $V_{DD} = \text{off level}$, please keep the level of input signals low or keep a high impedance.
- T_4 should be measured after the Module has been fully discharged between power off and on period.
- Interface signal should not be kept at high impedance when the power is on.

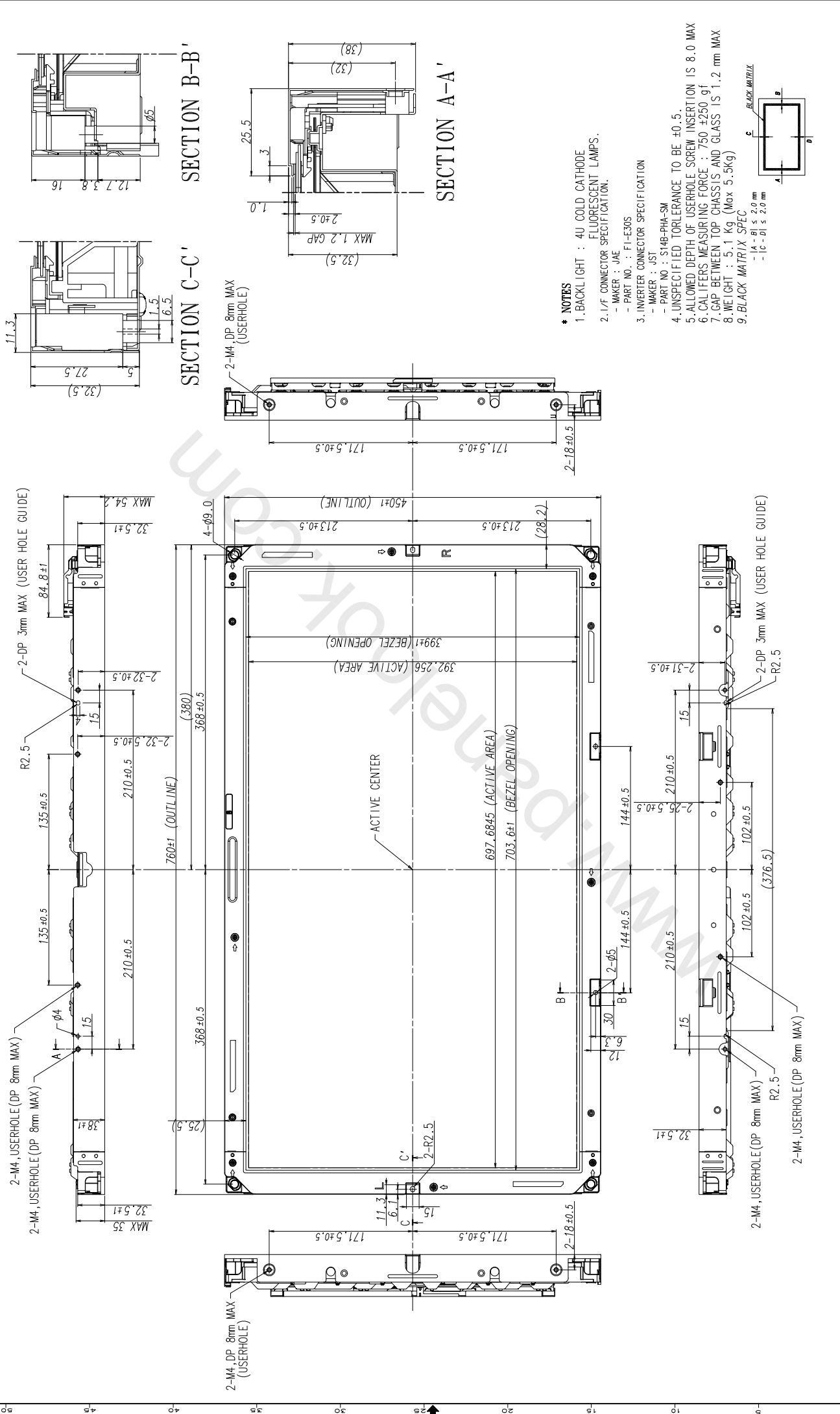

- ★ NOTES
- BACKLIGHT : 4U COLD CATHODE FLUORESCENT LAMPS.
 - 1/F CONNECTOR SPECIFICATION.
 - MAKER : JAE
 - PART NO. : F1-E30S
 - INVERTER CONNECTOR SPECIFICATION
 - MAKER : JST
 - PART NO. : S14B-PHA-SM
 - UNSPECIFIED TOLERANCE TO BE ± 0.5 .
 - ALLOWED DEPTH OF USERHOLE SCREW INSERTION IS 8.0 MAX
 - CALIFERS MEASURING FORCE : 750 ± 250 gf
 - GAP BETWEEN TOP CHASSIS AND GLASS IS 1.2 mm MAX
 - WEIGHT : 5.1 Kg (Max 5.5Kg)
 - BLACK MATRIX SPEC
 - A - B1 ≤ 2.0 mm
 - B - B1 ≤ 2.0 mm

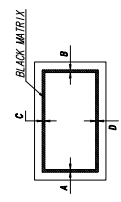

GENERAL TOLERANCE				REVISION				REASON	
STEP	LEVEL 1	LEVEL 2	LEVEL 3	REV/DATE	DESCRIPTION OF REVISION	APP'D BY	CHK'D BY	MODEL NAME	PART/SHEET NAME
0 < X < 4	±0.50	±0.3	±0.2	UNIT	MM	MM	MM	LPF020AP11	OUTLINE DIM. (PRIORITY)
4 < X < 16	±0.08	±0.05	±0.03	SCALE	1/2				
16 < X < 64	±0.12	±0.25	±0.15	TOLERANCE					
64 < X < 256	±0.25	±0.4	±0.14	LEVEL	3				

VER. 000

NO	PART NAME	CODE NO	SPECIFICATION	Q'TY	SPEC NO	REMARK
	OUTLINE DIMENSION	-	LTF320P11	1		

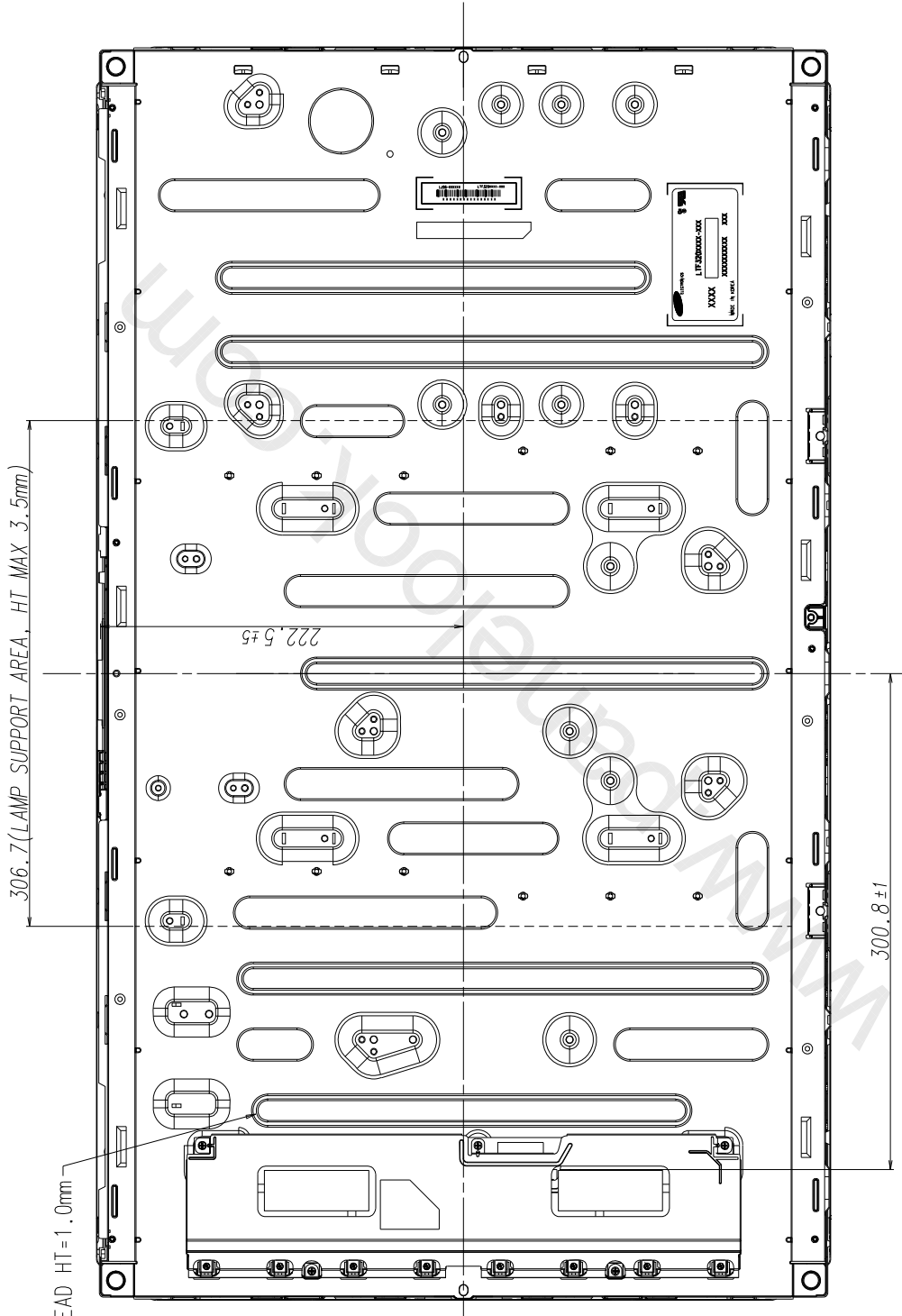

REV		DESCRIPTION OF REVISION		REASON		CHK'D BY	
1	DATE	UNIT	mm	DRW'N BY	DES'D BY	CHK'D BY	
2	SCALE	1:1	1:2				
3	TOLERANCE						
GENERAL TOLERANCE		LEVEL 1		LEVEL 2		LEVEL 3	
STEP							
0 < X ≤ 4	+0.05	+0.1	+0.2				
4 < X ≤ 16	+0.08	+0.15	+0.3				
16 < X ≤ 64	+0.12	+0.25	+0.5				
64 < X ≤ 256	+0.25	+0.4	+0.8				
SAMSUNG ELECTRONICS							
MODEL NAME		PART/SHEET NAME		CODE NO.		VER.	
		OUTLINE DIM. (REAR)				000	

8. Reliability Test

Item	Test condition	Quantity
Temperature Step stress	-20℃ ~ 60℃, 10Cycle, 80hr	4EA
HTOL	50℃ operation, 1000hr	8EA
LTOL	0℃ operation, 1000hr	4EA
LTOL 2	-20℃, -10℃ Each condition over 5hr off, over 1hr on	4EA
HTS	70℃ storage, 500hr	4EA
LTS	-30℃ storage, 500hr	4EA
THB	40℃ / 95%RH, 30sec On / Off, 500hr operation	4EA
WHTS	60℃ / 75%RH, 500hr	4EA
Thermal Shock	-20℃ (30min) ~ 60℃ (30min) storage, 200cycle	4EA
ALTITUDE	-10℃ ~ 45℃, 0 ~ 40,000ft, 18hr	2EA
ESD	contact : ± 8 kV, 150pF/330Ω, 200Point, 1 time/Point (operation) non-contact : ± 15 kV, 150pF/330Ω, 200Point, 1 time/Point (operation) Inverter input pin : ± 15 kV, 150pF/330Ω, 3 times/Pin	3EA
Vibration	10~300Hz/1.5G/10minSR, XYZ, 30min/axis	3EA
Shock	11msec, ± XYZ 1time/axis ~15Kg 50G, 11msec 15Kg ~ 20Kg ± XY 40G ± Z 30G, 11msec 20Kg ~ 30G, 11msec	3EA
Noise	On 90 min / Off 90 min	2 EA
Dust	5hr on/off (yellow earth 5sec spread / 5 min precipitation)	2 EA
Short term Image sticking	25~50℃ Mosaic pattern (9*10) 12hr fix	8 EA
Long term Image sticking	50℃ Mosaic pattern (9*10) 504hr fix	4 EA
PALLET Vibration	1.05 Grms, Random, Z axis 1Hr	1PALLET(30EA)
PALLET Drop	20cm, 4Edge(Bottom), 1Face(Bottom)	1PALLET(30EA)

[Result Evaluation Criteria]

Under the display quality test conditions with normal operation state, these should be no change which may affect practical display functions.

- * HTOL/ LTOL : High/Low Temperature Operating Life
- ** THB : Temperature Humidity Bias
- *** HTS/LTS : High/Low Temperature Storage
- **** WHTS : Wet High Temperature Storage

MODEL

LTF320AP11

Doc. No

07-000-S-101119

Page

24/29

9. PACKING

9.1 CARTON (Internal Package)

(1) Packing Form

Corrugated fiberboard box and corrugated cardboard as shock absorber

(2) Packing Method

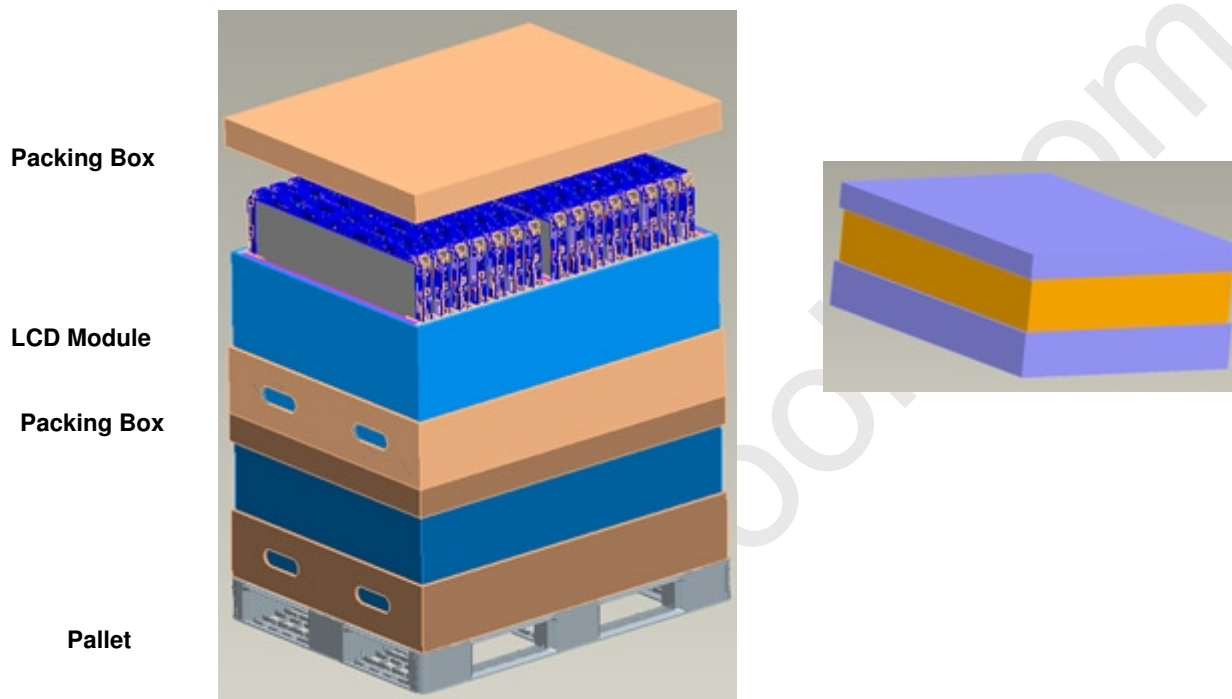

9.2 Packing Specification

Item	Specification	Remark
LCD Packing	30EA (15*2EA)	- 5.0kg / LCD - 11 kg / Packing Set - Packing Material: Paper
Desiccant(drier)	2 EA	10g/EA, Cobalt-dichloride-free
Pallet	1 EA	Pallet Weight: 5.3kg
Total Pallet Size	1150 * 850 * 1105	Length x Width x Height
Total Pallet Weight	177.9Kg	Module(5*30) + Pallet(5.3kg) + Packing SET(11)*2 +Desiccant(0.02x30=0.6kg)

MODEL

LTF320AP11

Doc. No

07-000-S-101119

Page

25/29

10. MARKING & OTHERS

A nameplate bearing followed by is affixed to a shipped product at the specified location on each product.

- (1) Parts number : LTF320AP11
- (2) Revision: Three letters
- (3) Lot number : X X X X XXX XX X

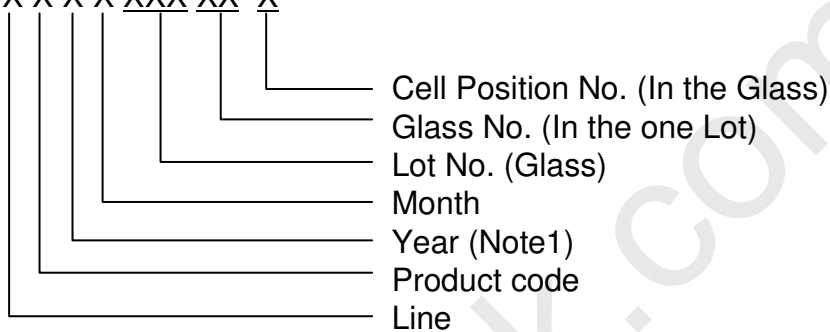

(4) Nameplate Indication

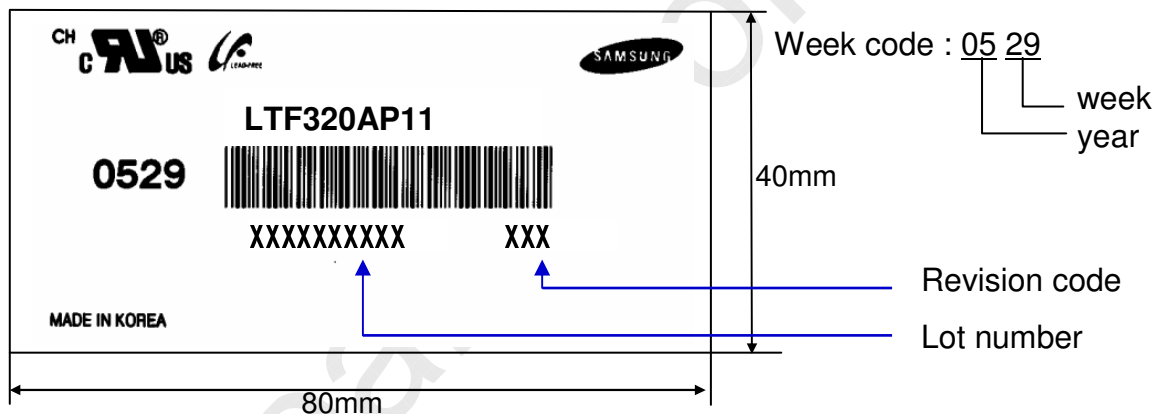

(5) Packing box attach

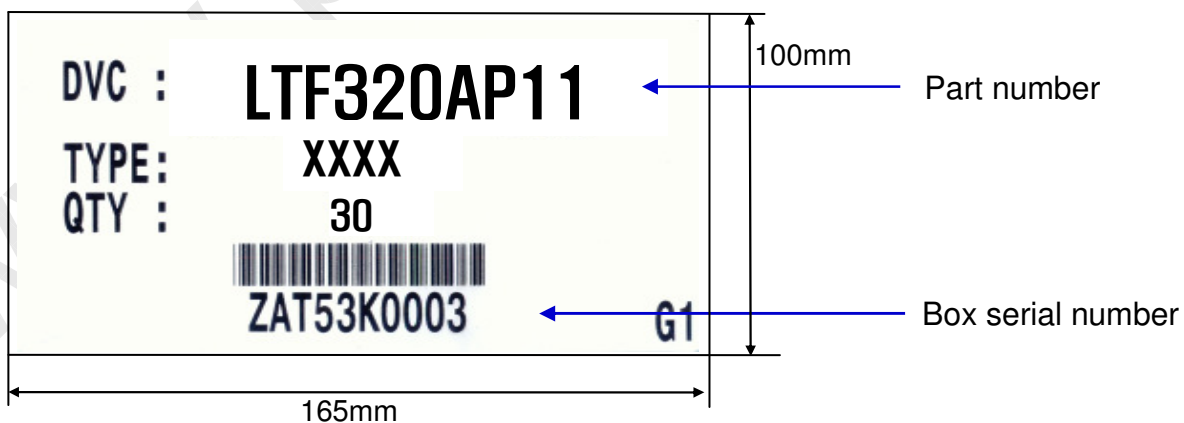

(6) Others

- 1. After service part
 Lamps cannot be replaced because of the narrow bezel structure.

MODEL	LTF320AP11	Doc. No	07-000-S-101119	Page	26/29
-------	------------	---------	-----------------	------	-------

11. General Precautions

11.1 Handling

- (a) When the Module is assembled, it should be attached to the system firmly using all mounting holes. Be careful not to twist and bend the Module.
- (b) Because the inverter use high voltage, it should be disconnected from power before it is assembled or disassembled.
- (c) Refrain from strong mechanical shock and / or any force to the Module. In addition to damage, this may cause improper operation or damage to the Module and CCFL back light.
- (d) Note that polarizers are very fragile and could be damage easily. Do not press or scratch the surface harder than a HB pencil lead.
- (e) Wipe off water droplets or oil immediately. If you leave the droplets for a long time, staining or discoloration may occur.
- (f) If the surface of the polarizer is dirty, clean it using absorbent cotton or soft cloth.
- (g) Desirable cleaners are water, IPA(Isopropyl Alcohol) or Hexane. Do not use Ketone type materials(ex. Acetone), Ethyl alcohol, Toluene, Ethyl acid or Methyl chloride. It might permanent damage to the polarizer due to chemical reaction.
- (h) If the liquid crystal material leaks from the panel, it should be kept away from the eyes or mouth . In case of contact with hands, legs or clothes, it must be washed away with soap thoroughly.
- (i) Protect the module from Electrostatic discharge. Otherwise the ASIC IC or Semiconductor would be damaged.
- (j) Use finger-stalls with soft gloves in order to keep display clean during the incoming inspection and assembly process.
- (k) Do not disassemble the Module.
- (l) Do not disassemble shield case of inverter & LVDS board.
- (m) Do not connect N.C pins. (Samsung internal use only)
- (n) Protection film for polarizer on the Module should be slowly peeled off just before use so that the electrostatic charge can be minimized. Must put on antistatic glove while handle a module
- (o) Pins of I/F connector should not be touched directly with bare hands.

MODEL**LTF320AP11****Doc. No****07-000-S-101119****Page****27/29**

11.2 Storage

- (a) Do not leave the Module in high temperature, and high humidity for a long time. It is highly recommended to store the Module with temperature from 0 to 35 °C and relative humidity of less than 70%.
- (b) Do not store the TFT-LCD Module in direct sunlight.
- (c) The Module should be stored in a dark place. It is prohibited to apply sunlight or fluorescent light in storing.

11.3 Operation

- (a) Do not connect or disconnect the Module in the "Power On" condition.
- (b) Power supply should always be turned on/off by the "Power on/off sequence"
- (c) Module has high frequency circuits. Sufficient suppression to the electromagnetic interference should be done by system manufacturers. Grounding and shielding methods may be important to minimize the interference.
- (d) The cable between the back light connector and its inverter power supply should be connected directly with a minimized length. A longer cable between the back light and the inverter may cause lower luminance of lamp(CCFT) and may require higher startup voltage(Vs).

11.4 Operation Condition Guide

- (a) The LCD product should be operated under normal conditions.
Normal condition is defined as below;
 - Temperature : 20 ± 15 °C
 - Humidity : 55 ± 20 %
 - Display pattern : continually changing pattern (Not stationary)
- (b) If the product will be used in extreme conditions such as high temperature, humidity, display patterns or operation time etc., It is strongly recommended to contact SEC for Application engineering advice. Otherwise, its reliability and function may not be guaranteed. Extreme conditions are commonly found at Airports, Transit Stations, Banks, Stock market, and Controlling systems.

MODEL**LTF320AP11****Doc. No****07-000-S-101119****Page****28/29**

11.5 Others

- (a) Ultra-violet ray filter is necessary for outdoor operation.
- (b) Avoid condensation of water. It may result in improper operation or disconnection of electrode.
- (c) Do not exceed the absolute maximum rating value. (supply voltage variation, input voltage variation, variation in part contents and environmental temperature, and so on)
Otherwise the Module may be damaged.
- (d) If the Module keeps displaying the same pattern for a long period of time, the image may be "sticked" to the screen.
To avoid image sticking, it is recommended to use a screen saver.
- (e) This Module has its circuitry PCB's on the rear side and should be handled carefully in order not to be stressed.
- (f) Please contact SEC in advance when you display the same pattern for a long time.

MODEL**LTF320AP11****Doc. No****07-000-S-101119****Page****29/29**