



Approval

Customer : Visual Display Division

DATE : 23.Aug.2010

SAMSUNG TFT-LCD**MODEL : LTF400HQ04(BN07-00956A)**Any Modification of Specification is not allowed without SEC's Permission.

NOTE :

Customer's Approval	
SIGNATURE	DATE

APPROVAED BY <i>Jeong min Heo</i>	DATE 23.Aug.2010
PREPARED BY Bong u Lee	DATE 23.Aug.2010

LCD Business

Samsung Electronics Co . , LTD.

MODEL	LTF400HQ04	Doc. No	06-000-S-100823	Page	1 / 27
-------	------------	---------	-----------------	------	--------

Contents

Revision History	(3)
General Description	(4)
General Information	(4)
1. Absolute Maximum Ratings	(5)
2. Optical Characteristics	(7)
3. Electrical Characteristics	(10)
3.1 TFT LCD Module	
3.2 Back Light Unit	
4. Block Diagram	(12)
5. Input Terminal Pin Assignment	(13)
5.1 Input Signal & Power	
5.2 LVDS Interface	
5.3 Input Signals, Basic Display Colors and Gray Scale of Each Color	
6. Interface Timing	(17)
6.1 Timing Parameters (DE only mode)	
6.2 Timing Diagrams of interface Signal (DE only mode)	
6.3 Power ON/OFF Sequence	
7. Outline Dimension	(20)
8. Reliability test	(22)
9. Packing	(23)
10. Marking & Others	(24)
11. General Precaution	(25)
11.1 Handling	
11.2 Storage	
11.3 Operation	
11.4 Operation Condition Guide	
11.5 Others	

MODEL

LTF400HQ04

Doc. No

06-000-S-100823

Page

2 / 27



Revision History

Date	Rev. No	Page	Summary
Aug 23, 2010	000	all	First issued

MODEL

LTF400HQ04

Doc. No

06-000-S-100823

Page

3 / 27

General Description

Description

LTF400HQ04 is a color active matrix liquid crystal display (LCD) that uses amorphous silicon TFT (Thin Film Transistor) as switching components. This model is composed of a TFT LCD panel, a driver circuit and a back light unit. The resolution of a 40.0" is 1920 x 1080 and this model can display up to 1.07 Billion colors with wide viewing angle of 89° or higher in all directions. This panel is intended to support applications to provide an excellent performance for Flat Panel Display such as Home-alone Multimedia TFT-LCD TV and High Definition TV.

Features

- RoHS compliance (Pb-free)
- High contrast & aperture ratio with wide color gamut
- SPVA (Super Patterned Vertical Align) mode
- Wide viewing angle ($\pm 178^\circ$)
- High speed response
- FHD resolution (16:9)
- Low Power consumption
- WLED (White Light Emitting Diode) Backlight
- DE (Data Enable) mode
- LVDS (Low Voltage Differential Signaling) interface (2pixel/clock)

General Information

Items	Specification	Unit	Note
Module Size	952(H _{TYP}) x 551(V _{TYP})	mm	±1.0mm
	35 (D _{Max})		
Weight	10,500 (Max)	g	
Pixel Pitch	0.46125(H) X 0.15375(W)	mm	
Active Display Area	885.6(H) X 498.15(V)	mm	
Surface Treatment	Haze 0% , Hard-coating(3H)		Glare
Display Colors	1.07Billion (10 bit Dithering)	colors	
Number of Pixels	1920 x 1080	pixel	
Pixel Arrangement	RGB vertical stripe		
Display Mode	Normally Black		
Luminance of White	450 (Typ.)	cd/m ²	

MODEL

LTF400HQ04

Doc. No

06-000-S-100823

Page

4 / 27

1. Absolute Maximum Ratings

If the condition exceeds maximum ratings, it can cause malfunction or unrecoverable damage to the device.

1.1 TFT LCD Module Absolute Maximum Ratings

($V_{DD}=12V$)

Item	Symbol	Min.	Max.	Unit	Note
Power Supply Voltage	V_{DD}	10.8	13.2	V	(1)

1.2 LED Unit Absolute Maximum Ratings

Item	Symbol	Max.	Unit	Remark
Operating Temperature Range	T_{op}	-20 ~ +70	°C	
Storage Temperature Range	T_{stg}	-30 ~ +70	°C	
Junction Temperature	T_j	110	°C	
Forward Current	I_f	0.16	A	Ccontinuous operating @String (1String/PCB)
Forward Voltage	V_f	112	V	Ccontinuous operating @String (64LEDs / 2String)
Thermal Resistance, Junction to PCB	$R_{th,JS}$	< 40K/W	K/W	

MODEL

LTF400HQ04

Doc. No

06-000-S-100823

Page

5 / 27

Note (1) $T_a = 25 \pm 2 \text{ }^\circ\text{C}$

(2) Temperature and relative humidity range are shown in the figure below.

a. 90 % RH Max. ($T_a \leq 39 \text{ }^\circ\text{C}$)

b. Relative Humidity is 90% or less. ($T_a > 39 \text{ }^\circ\text{C}$)

c. No condensation

(3) 11ms, sine wave, one time for $\pm X, \pm Y, \pm Z$ axis

(4) 10-300 Hz, Sweep rate 10min, 30min for X,Y,Z axis

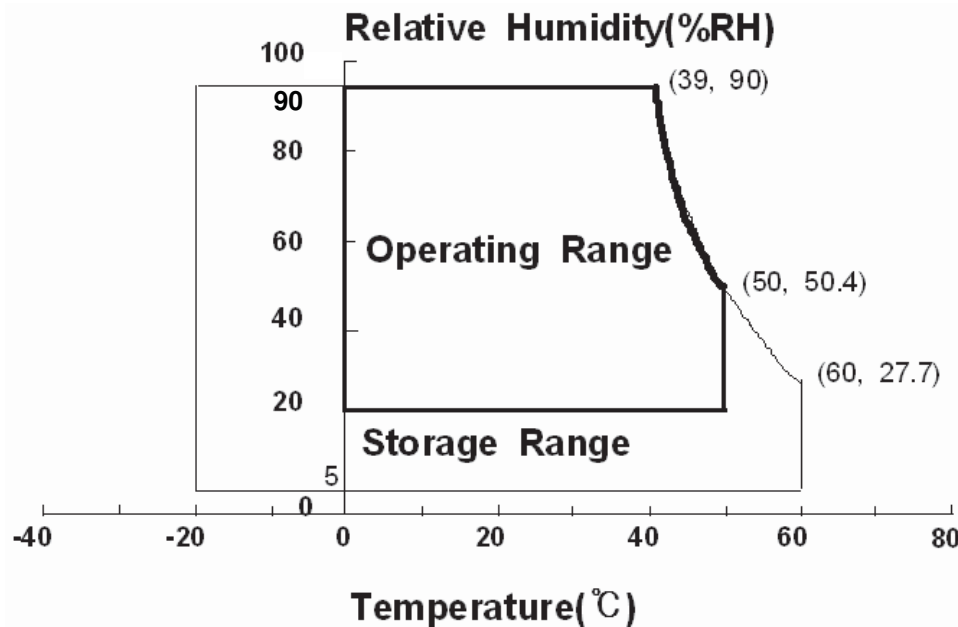
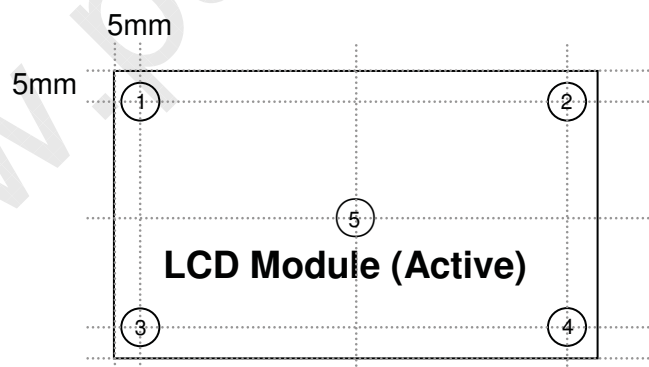

Fig. Temperature and Relative humidity range

(5) Definition of test point



ΔT should be less than $10 \text{ }^\circ\text{C}$ ($\Delta T = |T_{\text{OPR}} - T_{\text{MAX}}|$)

T_{OPR} : Temperature of the center of the glass surface (Test point 5)

$T_1 \sim T_4$: Temperature of each edge of the glass surface

T_{MAX} : The highest temperature of the glass surface

2. Optical Characteristics

The optical characteristics should be measured in a dark room or equivalent.

Measuring equipment : TOPCON RD-80S, TOPCON SR-3 ,ELDIM EZ-Contrast

(Ta = 25 ± 2°C, VDD=12.0V, fv=60Hz, fDCLK=74.25 MHz)

Item		Symbol	Condition	Min.	Typ.	Max.	Unit	Note
Contrast Ratio (Center of screen)		C/R	Normal $\theta_{L,R}=0$ $\theta_{U,D}=0$	-	5000	-		(1) SR-3
Response Time	G-to-G	Tg		-	4.5	9	msec	(3) RD-80S
Luminance of White (Center of screen)		Y_L		400	450	-	cd/m ²	(4) SR-3
Color Chromaticity (CIE 1931)	Red	Rx	Viewing Angle	TYP. -0.03	0.640	TYP. +0.03		(5),(6) SR-3
		Ry			0.330			
	Green	Gx			0.300			
		Gy			0.640			
	Blue	Bx			0.150			
		By			0.060			
	White	Wx			0.280			
		Wy			0.290			
Color Gamut		-	-	80	-	%	(5) SR-3	
Color Temperature		-	-	10000	-	K	(5) SR-3	
Viewing Angle	Hor.	θ_L	C/R ≥ 10	75	89	-	Degree	(6) EZ-Contrast
		θ_R		75	89	-		
	Ver.	θ_U		75	89	-		
		θ_D		75	89	-		
Brightness Uniformity (9 Points)		B_{uni}	-	-	25	%	(2) SR-3	

- Test Equipment Setup

The measurement should be executed in a stable, windless and dark room between 40min and 60min after lighting the back light at the given temperature for stabilization of the back light. This should be measured in the center of screen.

Total LED current : 105 mA / Duty 100%

Environment condition : Ta = 25 ± 2 °C

MODEL

LTF400HQ04

Doc. No

06-000-S-100823

Page

7 / 27

Photo detector	Field
SR3	1°
RD-80S	2°

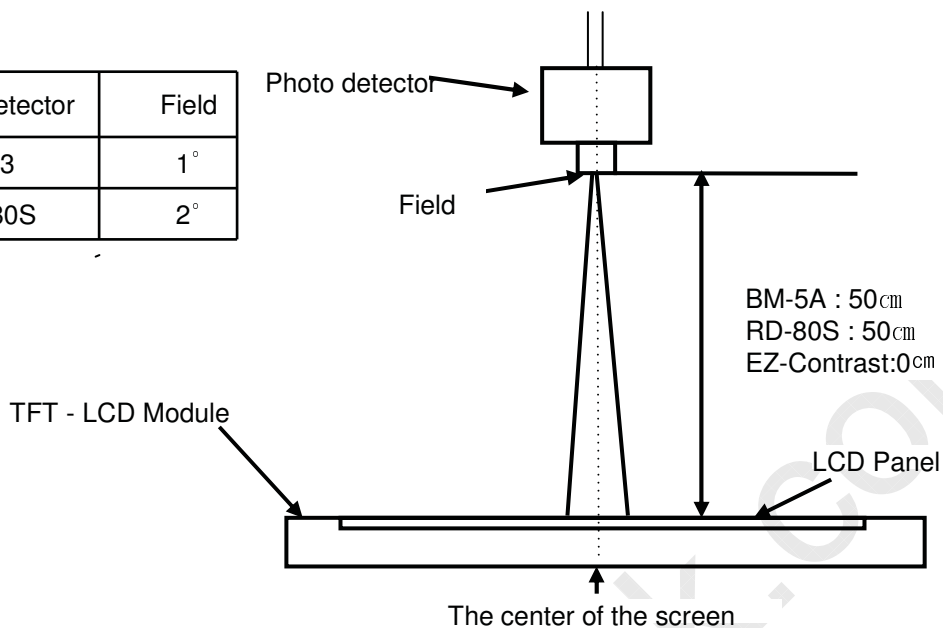

- Definition of test point

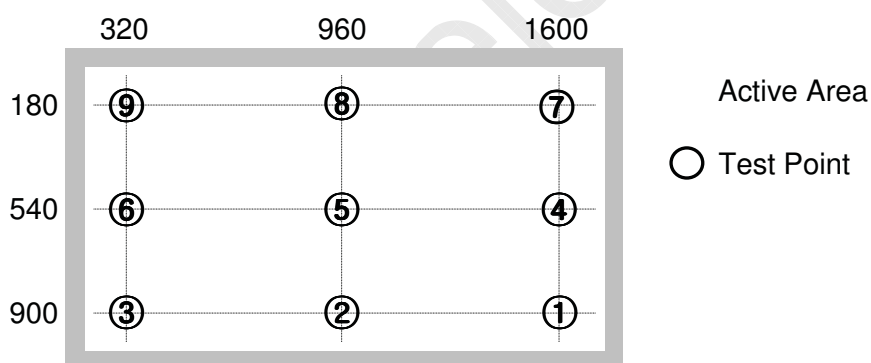

Note (1) Definition of Contrast Ratio (C/R)

: Ratio of gray max (Gmax) & gray min (Gmin) at the center point ⑤ of the panel

$$C/R = \frac{G \max}{G \min}$$

Gmax : Luminance with all pixels white

Gmin : Luminance with all pixels black

MODEL	LTF400HQ04	Doc. No	06-000-S-100823	Page	8 / 27
-------	------------	---------	-----------------	------	--------

Note (2) Definition of 9 points brightness uniformity (Test pattern : Full White)

$$B_{uni} = 100 * \frac{(B_{max} - B_{min})}{B_{max}}$$

Bmax : Maximum brightness

Bmin : Minimum brightness

Note (3) Definition of Response time : Sum of Tr, Tf

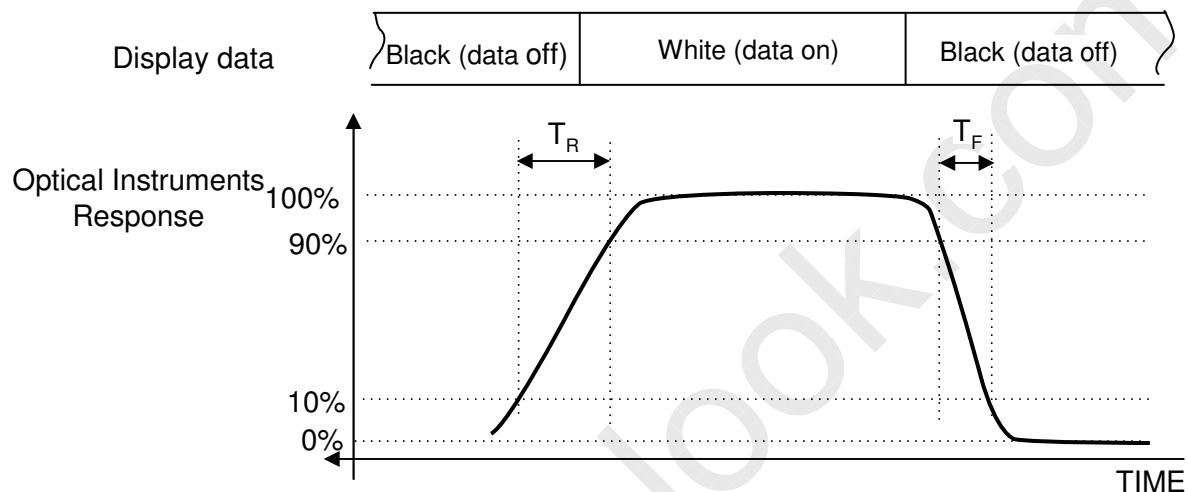

※ G-to-G : Average response time between Gray to Gray (Scale)

Note (4) Definition of Luminance of White : Luminance of white at center point ⑤

Note (5) Definition of Color Chromaticity (CIE 1931)

Color coordinate of Red, Green, Blue & White at center point ⑤

Note (6) Definition of Viewing Angle

: Viewing angle range (C/R ≥ 10)

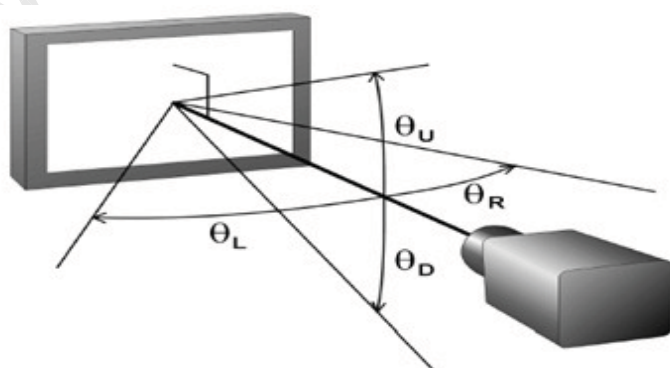

3. Electrical Characteristics

3.1 TFT LCD Module

The connector for display data & timing signal should be connected.

$T_a = 25^\circ\text{C} \pm 2^\circ\text{C}$

Item	Symbol	Min.	Typ.	Max.	Unit	Note
Voltage of Power Supply	V_{DD}	10.8	12.0	13.2	V	(1)
Current of Power Supply	(a) Black	-	1700	1950	mA	(2),(3)
	(b) White	-	1750	2000	mA	
	(c) N-pattern	-	1800	2050	mA	
Vsync Frequency	f_V	-	60	-	Hz	
Hsync Frequency	f_H	-	67.5	-	kHz	
Main Frequency	Fdclk	-	148.5	-	MHz	
Rush Current	I_{RUSH}	-	-	8	A	(4)

Note (1) The ripple voltage should be controlled under 10% of V_{DD} .

(2) $f_V=60\text{Hz}$, $f_{DCLK}=148.5\text{MHz}$, $V_{DD}=12.0\text{V}$, DC Current.

(3) Power dissipation check pattern (LCD Module only)

a) Black Pattern

b) White Pattern

c) N-Pattern

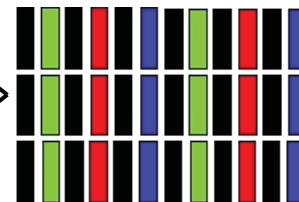
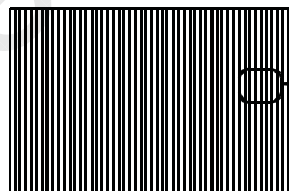
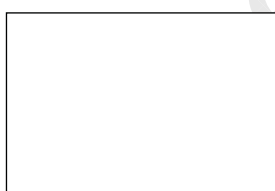
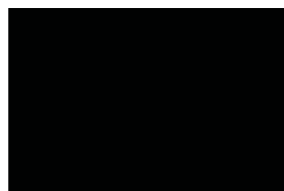

(4) Measurement Conditions

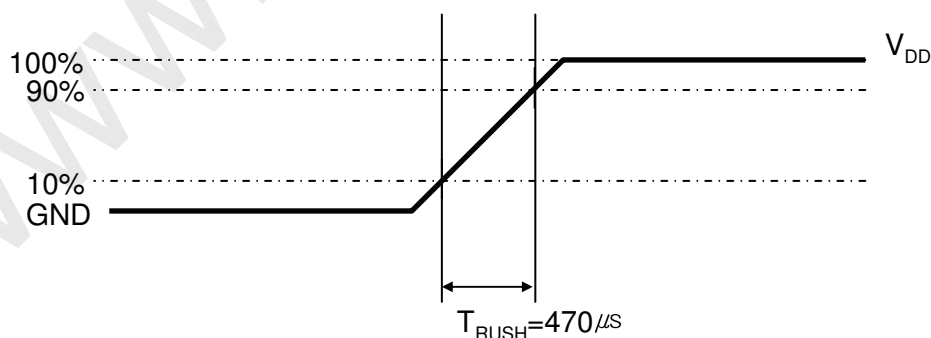

Rush Current I_{RUSH} can be measured when T_{RUSH} is $470\mu\text{s}$.

MODEL

LTF400HQ04

Doc. No

06-000-S-100823

Page

10 / 27

3.2 Back Light Unit

The back light unit contains 224 ea WLEDs (White Light Emitting Diode)

$T_a = 25 \pm 2^\circ\text{C}$

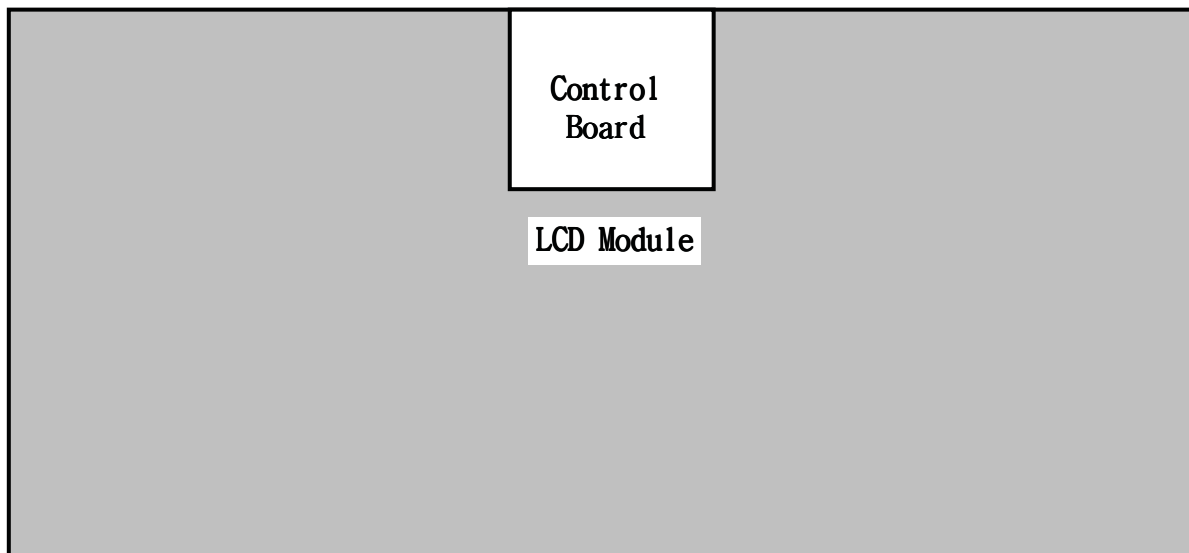

Item	Symbol	Min.	Typ.	Max.	Unit	Note
Operating Life Time	Hr	50000	-	-	Hour	(1)

Note (1) It is defined as the time to take until the brightness reduces to 50% of its original value.

[Operating condition : $T_a = 25 \pm 2^\circ\text{C}$]

4. Block Diagram

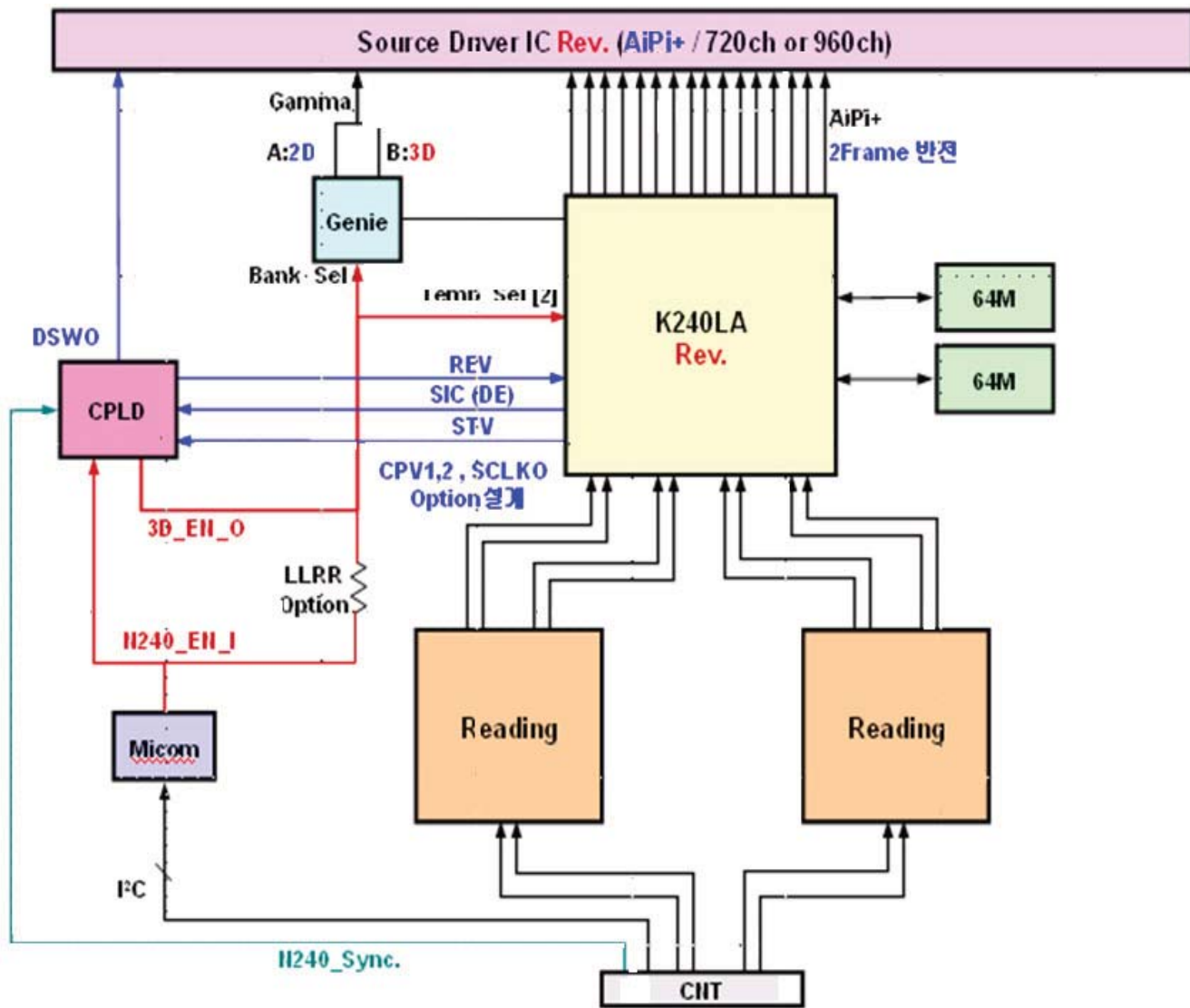

5. Input Terminal Pin Assignment

5.1. Input Signal & Power

Connector : 82Pin(UJU)

Pin Number	Signal	Pin Number	Signal	Pin Number	Signal
1	Panel_Vcc	27	RE[1]-	53	RO[4]+
2	Panel_Vcc	28	RE[1]+	54	RO[4]-
3	Panel_Vcc	29	RE[2]-	55	RO[3]+
4	Panel_Vcc	30	RE[2]+	56	RO[3]-
5	Panel_Vcc	31	GND	57	GND
6	N.C	32	RECLK-	58	ROCLK+
7	GND	33	RECLK+	59	ROCLK-
8	GND	34	GND	60	GND
9	GND	35	RE[3]-	61	RO[2]+
10	RO[0]-	36	RE[3]+	62	RO[2]-
11	RO[0]+	37	RE[4]-	63	RO[1]+
12	RO[1]-	38	RE[4]+	64	RO[1]-
13	RO[1]+	39	GND	65	RO[0]+
14	RO[2]-	40	SCL_I(for TCON)	66	RO[0]-
15	RO[2]+	41	Hsync_out	67	GND
16	GND	42	N240 Sync	68	RE[4]+
17	LOCLK-	43	WP(EEPROM)	69	RE[4]-
18	LOCLK+	44	SDA_I (for TCON)	70	RE[3]+
19	GND	45	LVDS_SEL	71	RE[3]-
20	RO[3]-	46	I2C SCL (For FRC)	72	GND
21	RO[3]+	47	FRC_nReset	73	RECLK+
22	RO[4]-	48	I2C SDA (For FRC)	74	RECLK-
23	RO[4]+	49	SW_PVCC	75	GND
24	GND	50	MAIN_Check (For FRC)	76	RE[2]+
25	RE[0]-	51	NC(HVS for LCD)	77	RE[2]-
26	RE[0]+	52	GND	78	RE[1]+
(NC) NOT CONNECTED : THIS PINS ARE ONLY USED FOR SEC INTERNAL OPERATIONS. (LVDS_SEL) : IF THIS PIN : HIGH (3.3V) → NORMAL NS LVDS FORMAT				79	RE[1]-
				80	RE[0]+
				81	RE[0]-
				82	GND

MODEL

LTF400HQ04

Doc. No

06-000-S-100823

Page

13 / 27

Note(1) Pin number

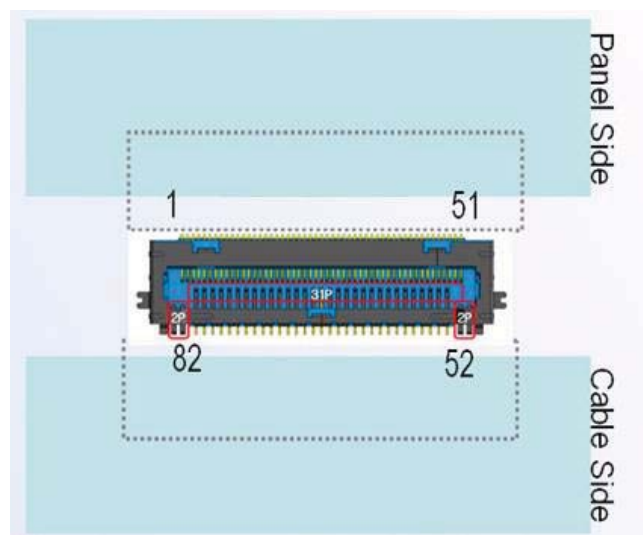

Fig. Connector diagram

- Power GND pins should be connected to the LCD's metal chassis.
- All power input pins should be connected together.
- All NC pin should be separated from other signal or power.

MODEL

LTF400HQ04

Doc. No

06-000-S-100823

Page

14 / 27

5.2 LVDS Interface

- LVDS Receiver : Tcon (merged)
- Data Format (JEIDA&Normal)

	LVDS pin	JEIDA -DATA	Normal
TxOUT/RxIN0	TxIN/RxOUT0	R4	R0
	TxIN/RxOUT1	R5	R1
	TxIN/RxOUT2	R6	R2
	TxIN/RxOUT3	R7	R3
	TxIN/RxOUT4	R8	R4
	TxIN/RxOUT6	R9	R5
	TxIN/RxOUT7	G4	G0
TxOUT/RxIN1	TxIN/RxOUT8	G5	G1
	TxIN/RxOUT9	G6	G2
	TxIN/RxOUT12	G7	G3
	TxIN/RxOUT13	G8	G4
	TxIN/RxOUT14	G9	G5
	TxIN/RxOUT15	B4	B0
	TxIN/RxOUT18	B5	B1
TxOUT/RxIN2	TxIN/RxOUT19	B6	B2
	TxIN/RxOUT20	B7	B3
	TxIN/RxOUT21	B8	B4
	TxIN/RxOUT22	B9	B5
	TxIN/RxOUT24	HSYNC	HSYNC
	TxIN/RxOUT25	VSYNC	VSYNC
	TxIN/RxOUT26	DEN	DEN
TxOUT/RxIN3	TxIN/RxOUT27	R2	R6
	TxIN/RxOUT5	R3	R7
	TxIN/RxOUT10	G2	G6
	TxIN/RxOUT11	G3	G7
	TxIN/RxOUT16	B2	B6
	TxIN/RxOUT17	B3	B7
	TxIN/RxOUT23	RESERVED	RESERVED
TxOUT/RxIN4	TxIN/RxOUT28	R0	R8
	TxIN/RxOUT29	R1	R9
	TxIN/RxOUT30	G0	G8
	TxIN/RxOUT31	G1	G9
	TxIN/RxOUT32	B0	B8
	TxIN/RxOUT33	B1	B9
	TxIN/RxOUT34	RESERVED	RESERVED

MODEL

LTF400HQ04

Doc. No

06-000-S-100823

Page

15 / 27

5.3 Input Signals, Basic Display Colors and Gray Scale of Each Color

COLOR	DISPLAY (8bit)	DATA SIGNAL																												GRAY SCALE LEVEL	
		RED										GREEN										BLUE									
		R0	R1	R2	R3	R4	R5	R6	R7	R8	R9	G0	G1	G2	G3	G4	G5	G6	G7	G8	G9	B0	B1	B2	B3	B4	B5	B6	B7		B8
BASIC COLOR	BLACK	0	0	0	0	0	0	0	0	0	0	0	0	0	0	0	0	0	0	0	0	0	0	0	0	0	0	0	0	0	-
	BLUE	0	0	0	0	0	0	0	0	0	0	0	0	0	0	0	0	0	0	0	0	0	1	1	1	1	1	1	1	1	-
	GREEN	0	0	0	0	0	0	0	0	0	0	1	1	1	1	1	1	1	1	1	1	1	0	0	0	0	0	0	0	0	-
	CYAN	0	0	0	0	0	0	0	0	0	0	0	1	1	1	1	1	1	1	1	1	1	1	1	1	1	1	1	1	1	-
	RED	1	1	1	1	1	1	1	1	1	0	0	0	0	0	0	0	0	0	0	0	0	0	0	0	0	0	0	0	0	-
	MAGENTA	1	1	1	1	1	1	1	1	1	0	0	0	0	0	0	0	0	0	0	0	0	1	1	1	1	1	1	1	1	-
	YELLOW	1	1	1	1	1	1	1	1	1	1	1	1	1	1	1	1	1	1	1	1	1	0	0	0	0	0	0	0	0	-
	WHITE	1	1	1	1	1	1	1	1	1	1	1	1	1	1	1	1	1	1	1	1	1	1	1	1	1	1	1	1	1	-
GRAY SCALE OF RED	BLACK	0	0	0	0	0	0	0	0	0	0	0	0	0	0	0	0	0	0	0	0	0	0	0	0	0	0	0	0	R0	
	DARK ↑	1	0	0	0	0	0	0	0	0	0	0	0	0	0	0	0	0	0	0	0	0	0	0	0	0	0	0	0	R1	
		0	1	0	0	0	0	0	0	0	0	0	0	0	0	0	0	0	0	0	0	0	0	0	0	0	0	0	0	R2	
		:	:	:	:	:	:	:	:	:	:	:	:	:	:	:	:	:	:	:	:	:	:	:	:	:	:	:	:	:	R3~R1020
		:	:	:	:	:	:	:	:	:	:	:	:	:	:	:	:	:	:	:	:	:	:	:	:	:	:	:	:	:	
	↓ LIGHT	1	0	1	1	1	1	1	1	1	0	0	0	0	0	0	0	0	0	0	0	0	0	0	0	0	0	0	0	R1021	
		0	1	1	1	1	1	1	1	1	1	0	0	0	0	0	0	0	0	0	0	0	0	0	0	0	0	0	0	R1022	
	RED	1	1	1	1	1	1	1	1	1	0	0	0	0	0	0	0	0	0	0	0	0	0	0	0	0	0	0	0	R1023	
GRAY SCALE OF GREEN	BLACK	0	0	0	0	0	0	0	0	0	0	0	0	0	0	0	0	0	0	0	0	0	0	0	0	0	0	0	0	G0	
	DARK ↑	0	0	0	0	0	0	0	0	0	0	1	0	0	0	0	0	0	0	0	0	0	0	0	0	0	0	0	0	G1	
		0	0	0	0	0	0	0	0	0	0	0	1	0	0	0	0	0	0	0	0	0	0	0	0	0	0	0	0	G2	
		:	:	:	:	:	:	:	:	:	:	:	:	:	:	:	:	:	:	:	:	:	:	:	:	:	:	:	:	G3~G1020	
		:	:	:	:	:	:	:	:	:	:	:	:	:	:	:	:	:	:	:	:	:	:	:	:	:	:	:	:		:
	↓ LIGHT	0	0	0	0	0	0	0	0	0	0	0	1	0	1	1	1	1	1	1	1	1	0	0	0	0	0	0	0	G1021	
		0	0	0	0	0	0	0	0	0	0	0	1	1	1	1	1	1	1	1	1	1	0	0	0	0	0	0	0	G1022	
	GREEN	0	0	0	0	0	0	0	0	0	0	0	1	1	1	1	1	1	1	1	1	1	0	0	0	0	0	0	0	G1023	
GRAY SCALE OF BLUE	BLACK	0	0	0	0	0	0	0	0	0	0	0	0	0	0	0	0	0	0	0	0	0	0	0	0	0	0	0	0	B0	
	DARK ↑	0	0	0	0	0	0	0	0	0	0	0	0	0	0	0	0	0	0	0	0	0	1	0	0	0	0	0	0	B1	
		0	0	0	0	0	0	0	0	0	0	0	0	0	0	0	0	0	0	0	0	0	0	1	0	0	0	0	0	B2	
		:	:	:	:	:	:	:	:	:	:	:	:	:	:	:	:	:	:	:	:	:	:	:	:	:	:	:	:	B3~B1020	
		:	:	:	:	:	:	:	:	:	:	:	:	:	:	:	:	:	:	:	:	:	:	:	:	:	:	:	:		:
	↓ LIGHT	0	0	0	0	0	0	0	0	0	0	0	0	0	0	0	0	0	0	0	0	0	0	1	0	1	1	1	1	B1021	
		0	0	0	0	0	0	0	0	0	0	0	0	0	0	0	0	0	0	0	0	0	0	1	1	1	1	1	1	B1022	
	BLUE	0	0	0	0	0	0	0	0	0	0	0	0	0	0	0	0	0	0	0	0	0	0	1	1	1	1	1	1	1	B1023

Note) Definition of Gray :
 Rn : Red Gray, Gn : Green Gray, Bn : Blue Gray (n = Gray level)
 Input Signal : 0 = Low level voltage, 1 = High level voltage

6. Interface Timing

6.1 Timing Parameters (DE only mode)

SIGNAL	ITEM	SYMBOL	MIN.	TYP.	MAX.	Unit	NOTE
Clock	Frequency	$1/T_C$	-	148.5	-	MHz	-
Hsync		F_H	-	67.5	-	KHz	-
Vsync		F_V	-	60	-	Hz	-
Vertical Display Term	Active Display Period	T_{VD}	-	1080	-	Lines	-
	Vertical Total	T_V	-	1125	-	Lines	-
Horizontal Display Term	Active Display Period	T_{HD}	-	1920	-	Clock s	-
	Horizontal Total	T_H	-	2200	-	clocks	-

Note) This product is DE only mode. The input of Hsync & Vsync signal does not have an effect on normal operation.

(1) Test Point : TTL control signal and CLK at LVDS Tx input terminal in system

(2) Internal $V_{DD} = 3.3V$

(3) Spread spectrum

- Modulation rate (max) : $\pm 1.5\%$

- Modulation Frequency : Max 300kHz

6.2 Timing diagrams of interface signal (DE only mode)

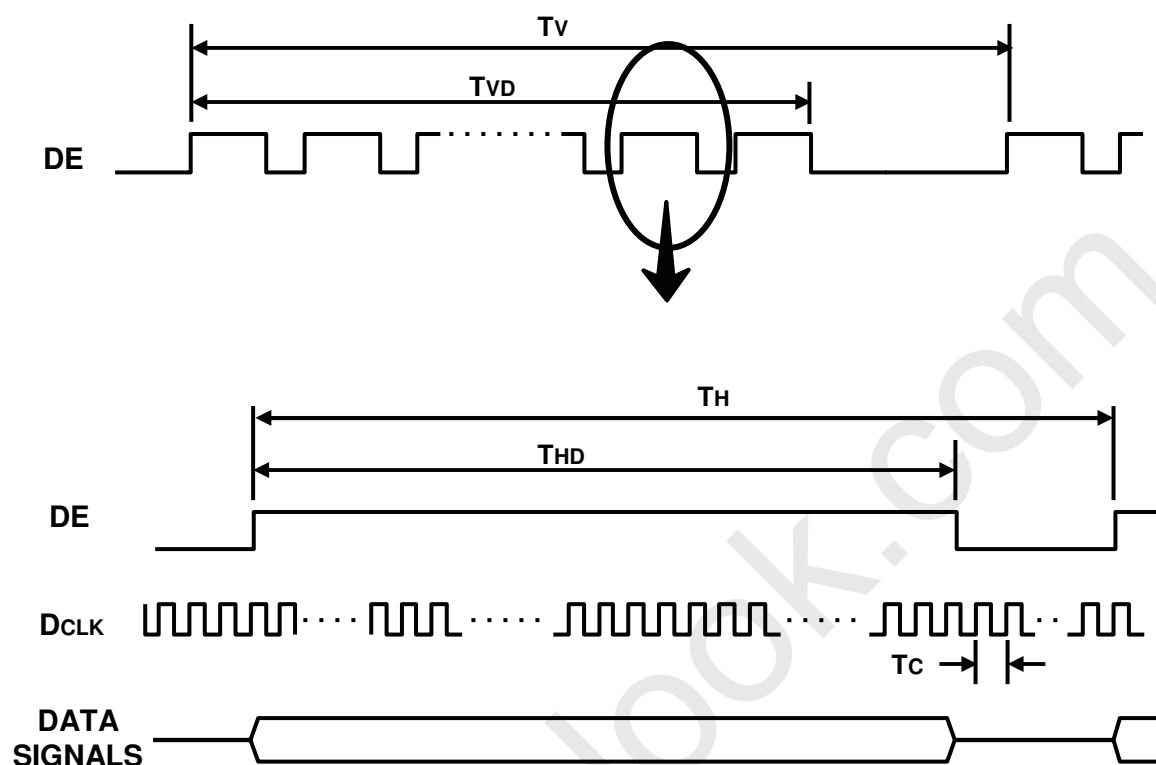

6.4 Power ON/OFF Sequence

To prevent a latch-up or DC operation of the LCD Module, the power on/off sequence should be as the diagram below.

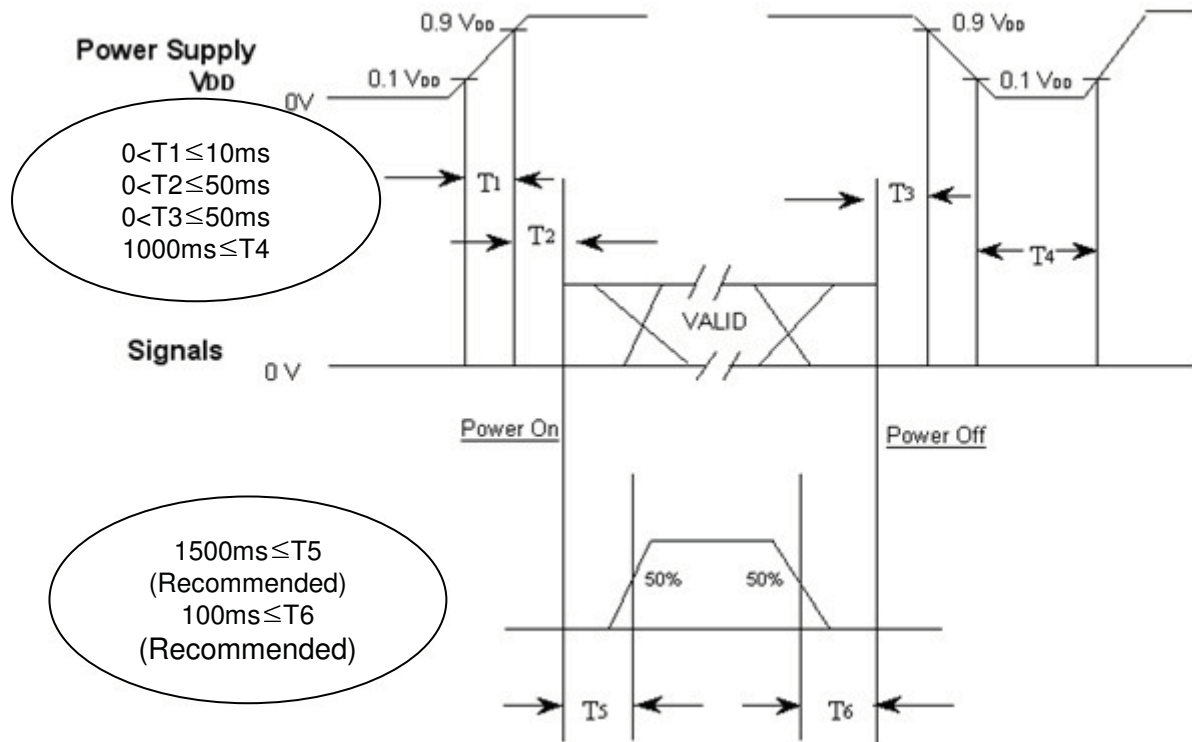

T_1 : V_{DD} rising time from 10% to 90%

T_2 : The time from V_{DD} to valid data at power ON.

T_3 : The time from valid data off to V_{DD} off at power Off.

T_4 : V_{DD} off time for Windows restart

T_5 : The time from valid data to B/L enable at power ON.

T_6 : The time from valid data off to B/L disable at power Off.

- The supply voltage of the external system for the Module input should be the same as the definition of V_{DD} .
- Apply the lamp voltage within the LCD operation range. When the back light turns on before the LCD operation or the LCD turns off before the back light turns off, the display may momentarily show abnormal screen.
- In case of V_{DD} = off level, please keep the level of input signals low or keep a high impedance.
- T_4 should be measured after the Module has been fully discharged between power off and on period.
- Interface signal should not be kept at high impedance when the power is on.

8. Reliability Test

Item	Test condition	Quantity
Temperature Step stress	-20℃ ~ 60℃, 10Cycle, 80hr	4EA
HTOL	50℃ operation, 1000hr	8EA
LTOL	0℃ operation, 1000hr	4EA
LTOL 2	-20℃, -10℃ Each condition over 5hr off, over 1hr on	4EA
HTS	70℃ storage, 500hr	4EA
LTS	-30℃ storage, 500hr	4EA
THB	40℃ / 95%RH, 30sec On / Off, 500hr operation	4EA
WHTS	60℃ / 75%RH, 500hr	4EA
Thermal Shock	-20℃ (30min) ~ 60℃ (30min) storage, 200cycle	4EA
ALTITUDE	-10℃ ~ 45℃, 0 ~ 40,000ft, 18hr	2EA
ESD	contact : ± 8 kV, 150pF/330Ω, 200Point, 1 time/Point (operation) non-contact : ± 15 kV, 150pF/330Ω, 200Point, 1 time/Point (operation) Inverter input pin : ± 15 kV, 150pF/330Ω, 3 times/Pin	3EA
Vibration	10~300Hz/1.5G/10minSR, XYZ, 30min/axis	3EA
Shock	11msec, ± XYZ 1time/axis ~15Kg 50G, 11msec 15Kg ~ 20Kg ± XY 40G ± Z 30G, 11msec 20Kg ~ 30G, 11msec	3EA
Noise	On 90 min / Off 90 min	2 EA
Dust	5hr on/off (yellow earth 5sec spread / 5 min precipitation)	2 EA
Short term Image sticking	25~50℃ Mosaic pattern (9*10) 12hr fix	8 EA
Long term Image sticking	50℃ Mosaic pattern (9*10) 504hr fix	4 EA
PALLET Vibration	1.05 Grms, Random, Z axis 1Hr	1PALLET(15EA)
PALLET Drop	20cm, 4Edge(Bottom), 1Face(Bottom)	1PALLET(15EA)

[Result Evaluation Criteria]

Under the display quality test conditions with normal operation state, these should be no change which may affect practical display functions.

- * HTOL/ LTOL : High/Low Temperature Operating Life
- ** THB : Temperature Humidity Bias
- *** HTS/LTS : High/Low Temperature Storage
- **** WHTS : Wet High Temperature Storage

MODEL

LTF400HQ04

Doc. No

06-000-S-100823

Page

22 / 27

9. PACKING

9.1 CARTON (Internal Package)

(1) Packing Form

Corrugated fiberboard box and corrugated cardboard as shock absorber

(2) Packing Method

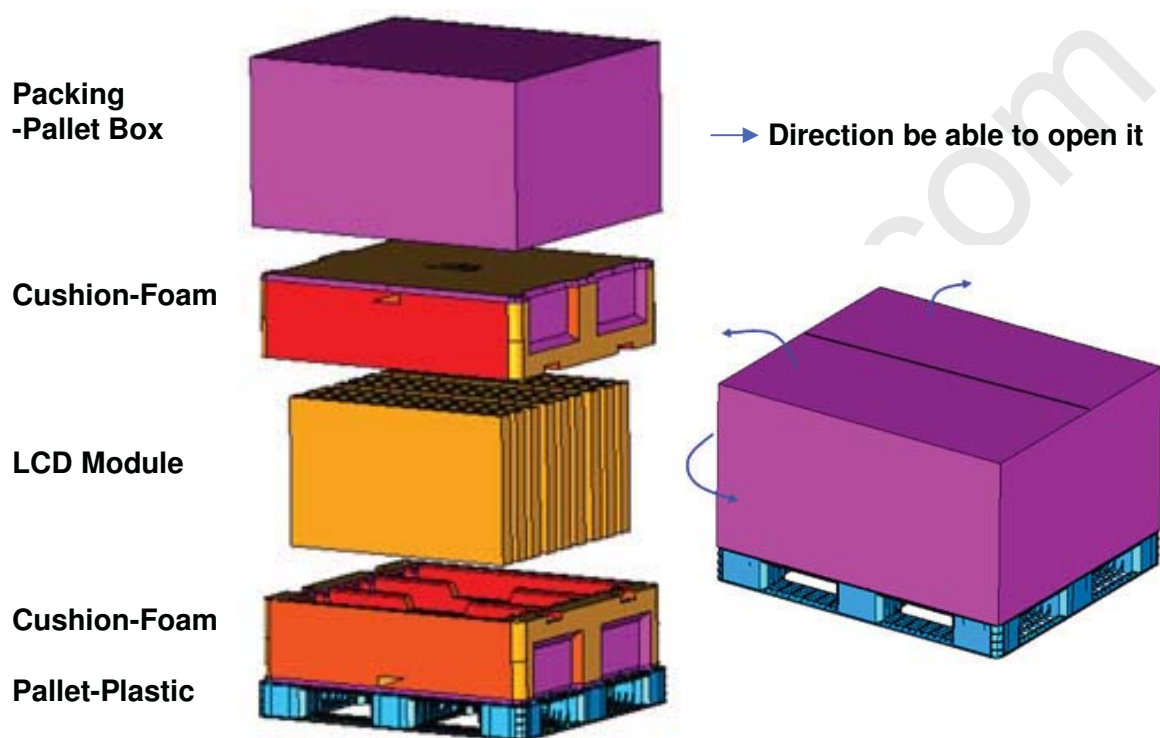

9.2 Packing Specification

Item	Specification	Remark
LCD Packing	15 ea / (Packing-Pallet Box)	1. 135 Kg / LCD (15ea) 2. 7 Kg / Cushion-pallet (2ea) 3. 6.7 Kg / Packing-Pallet Box (1ea) 4. Cushion-pallet Material : EPS 5. Packing-Pallet Box Material : DW4
Pallet	1Box / Pallet	1. Pallet weight = 8kg
Packing Direction	Vertical	
Total Pallet Size	H x V x height	1150mm(H) x 985mm(V) x 609mm(height)
Total Pallet Weight	156.7 kg	Pallet(8kg) + Module(110kg) + Cushion(up+botton=7kg) + Pallet-BOX(6.7kg)

MODEL

LTF400HQ04

Doc. No

06-000-S-100823

Page

23 / 27



10. MARKING & OTHERS

A nameplate bearing followed by is affixed to a shipped product at the specified location on each product.

- (1) Part number : LTF400HQ04
- (2) Revision: Three letters
- (3) Lot number : X X X X XXX XX X

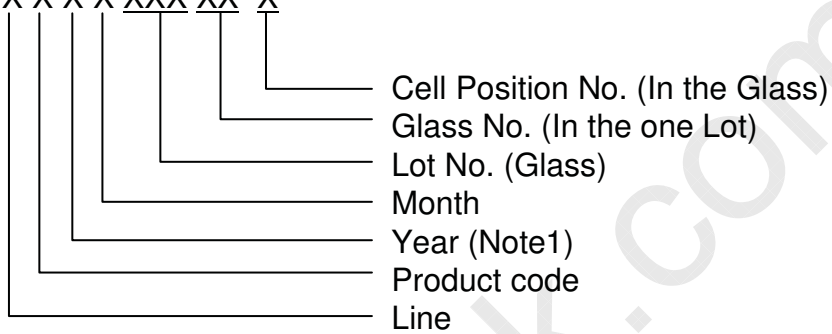

(4) Nameplate Indication

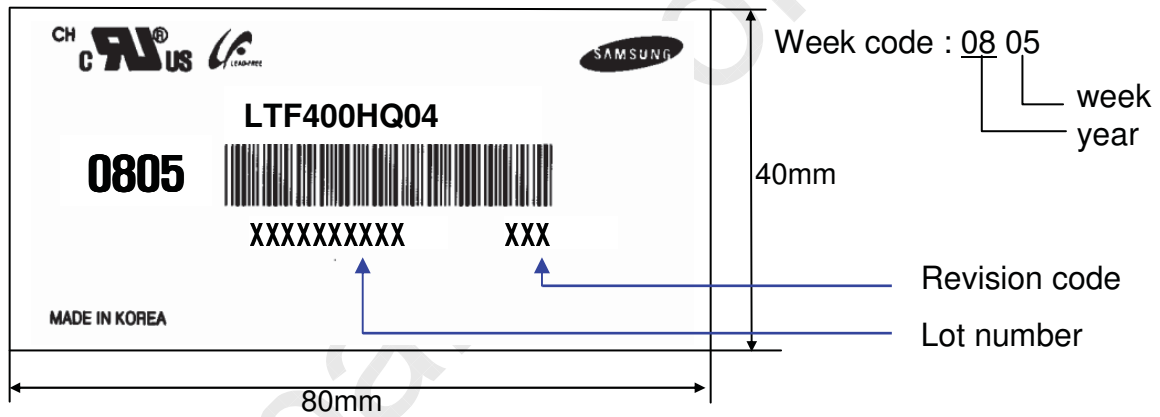

(5) Packing box attach

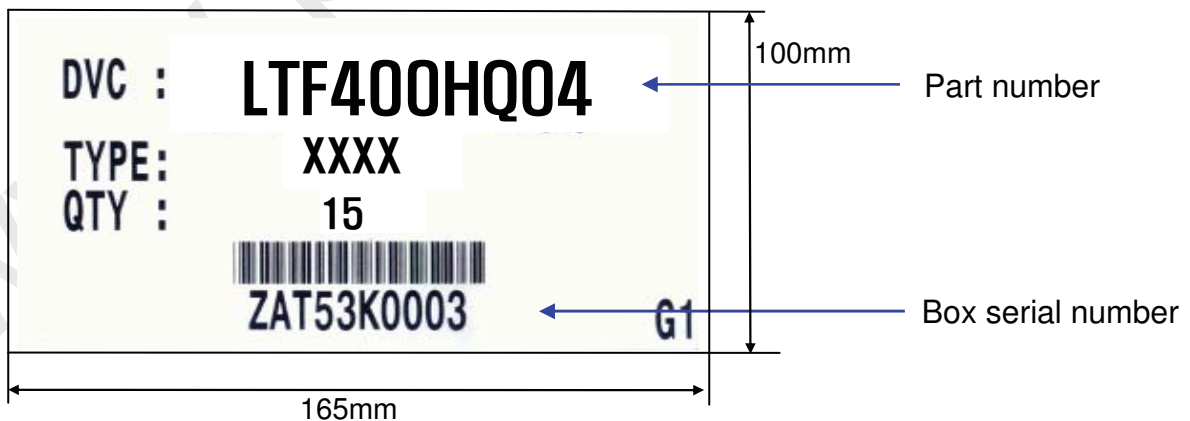

(6) Others

- 1. After service part
 Lamps cannot be replaced because of the narrow bezel structure.

MODEL	LTF400HQ04	Doc. No	06-000-S-100823	Page	24 / 27
-------	------------	---------	-----------------	------	---------

11. General Precautions

11.1 Handling

- (a) When the Module is assembled, it should be attached to the system firmly using all mounting holes. Be careful not to twist and bend the Module.
- (b) Refrain from strong mechanical shock and / or any force to the Module.
In addition to damage, this may cause improper operation or damage to the Module and LED back light.
- (c) Note that polarizers are very fragile and could be damage easily.
Do not press or scratch the surface harder than a HB pencil lead.
- (d) Wipe off water droplets or oil immediately. If you leave the droplets for a long time, staining or discoloration may occur.
- (e) If the surface of the polarizer is dirty, clean it using absorbent cotton or soft cloth.
- (f) Desirable cleaners are water, IPA(Isopropyl Alcohol) or Hexane.
Do not use Ketone type materials(ex. Acetone), Ethyl alcohol, Toluene, Ethyl acid or Methyl chloride. It might permanent damage to the polarizer due to chemical reaction.
- (g) If the liquid crystal material leaks from the panel, it should be kept away from the eyes or mouth . In case of contact with hands, legs or clothes, it must be washed away with soap thoroughly.
- (h) Protect the module from Electrostatic discharge. Otherwise the ASIC IC or Semiconductor would be damaged.
- (i) Use finger-stalls with soft gloves in order to keep display clean during the incoming inspection and assembly process.
- (j) Do not disassemble the Module.
- (k) Do not disassemble shield case of inverter & LVDS board.
- (l) Do not connect N.C pins. (Samsung internal use only)
- (m) Protection film for polarizer on the Module should be slowly peeled off just before use so that the electrostatic charge can be minimized. Must put on antistatic glove while handle a module
- (o) Pins of I/F connector should not be touched directly with bare hands.

MODEL	LTF400HQ04	Doc. No	06-000-S-100823	Page	25 / 27
-------	------------	---------	-----------------	------	---------

11.2 Storage

- (a) Do not leave the Module in high temperature, and high humidity for a long time. It is highly recommended to store the Module with temperature from 0 to 35 °C and relative humidity of less than 70%.
- (b) Do not store the TFT-LCD Module in direct sunlight.
- (c) The Module should be stored in a dark place. It is prohibited to apply sunlight or fluorescent light in storing.

11.3 Operation

- (a) Do not connect or disconnect the Module in the "Power On" condition.
- (b) Power supply should always be turned on/off by the "Power on/off sequence"
- (c) Module has high frequency circuits. Sufficient suppression to the electromagnetic interference should be done by system manufacturers. Grounding and shielding methods may be important to minimize the interference.
- (d) The cable between the back light connector and its power supply should be connected directly with a minimized length. A longer cable between the back light and the inverter may cause lower luminance of lamp and may require higher startup voltage(Vs).

11.4 Operation Condition Guide

- (a) The LCD product should be operated under normal conditions.
Normal condition is defined as below;
 - Temperature : 20 ± 15 °C
 - Humidity : 55 ± 20 %
 - Display pattern : continually changing pattern (Not stationary)
- (b) If the product will be used in extreme conditions such as high temperature, humidity, display patterns or operation time etc., It is strongly recommended to contact SEC for Application engineering advice. Otherwise, its reliability and function may not be guaranteed. Extreme conditions are commonly found at Airports, Transit Stations, Banks, Stock market, and Controlling systems.

MODEL	LTF400HQ04	Doc. No	06-000-S-100823	Page	26 / 27
-------	------------	---------	-----------------	------	---------

11.5 Others

- (a) Ultra-violet ray filter is necessary for outdoor operation.
- (b) Avoid condensation of water. It may result in improper operation or disconnection of electrode.
- (c) Do not exceed the absolute maximum rating value. (supply voltage variation, input voltage variation, variation in part contents and environmental temperature, and so on)
Otherwise the Module may be damaged.
- (d) If the Module keeps displaying the same pattern for a long period of time, the image may be "sticked" to the screen.
To avoid image sticking, it is recommended to use a screen saver.
- (e) This Module has its circuitry PCB's on the rear side and should be handled carefully in order not to be stressed.
- (f) Please contact SEC in advance when you display the same pattern for a long time.

MODEL	LTF400HQ04	Doc. No	06-000-S-100823	Page	27 / 27
-------	------------	---------	-----------------	------	---------