



ELECTRONICS

# Product Information

**ISSUE DATE : 2001-10-12**

**MODEL : LTM170E5-L03**

**Note : This Product information is subject to change after 3 months of issuing date**

Prepared by AMLCD Application Engineering Group

**Samsung Electronics Co . , LTD.**

## **Contents**

|  |       |      |
|--|-------|------|
| General Description  | ----- | (3)  |
| 1. Absolute Maximum Ratings  | ----- | (4)  |
| 1.1 Absolute ratings of environment                                  |       |      |
| 1.2 Electrical Absolute Ratings                                      |       |      |
| 2. Optical Characteristics   | ----- | (6)  |
| 3. Electrical Characteristics  | ----- | (9)  |
| 3.1 TFT LCD Module   |       |      |
| 3.2 Back-light Unit  |       |      |
| 4. Block Diagram   | ----- | (12) |
| 4.1 TFT LCD Module   |       |      |
| 4.2 Back-light Unit  |       |      |
| 5. Input Terminal Pin Assignment                                     | ----- | (13) |
| 5.1 Input Signal & Power   |       |      |
| 5.2 LVDS Interface (1)   |       |      |
| 5.3 LVDS Interface (2)   |       |      |
| 5.4 Back-light Unit  |       |      |
| 5.5 Input Signals, Basic Display Colors and Gray Scale of Each Color |       |      |
| 6. Interface Timing  | ----- | (20) |
| 6.1 Timing Parameters (DE only mode)                                 |       |      |
| 6.2 Timing Diagrams of Interface Signal (DE only mode)               |       |      |
| 6.3 Power ON/OFF Sequence  |       |      |
| 7. Outline Dimension   | ----- | (23) |
| 8. General Precaution  | ----- | (25) |
| 8.1 Handling   |       |      |
| 8.2 Storage  |       |      |
| 8.3 Operation  |       |      |
| 8.4 Others   |       |      |

## General Description

### \* Description

LTM170E5-L03 is a color active matrix TFT (Thin Film Transistor) liquid crystal display (LCD) that uses amorphous silicon TFTs as a switching devices. This model is composed of a TFT LCD panel, a driver circuit and a back-light system. The resolution of a 17.0" contains 1280 x 1024 pixels and can display up to 16.7 million colors with wide viewing angle of 85° or higher in all directions. (Vertical viewing angle : 170° , Horizontal viewing angle : 170°)

### \* Features

- High contrast ratio, high aperture structure
- PVA(Patterned Vertical Alignment) mode
- Wide viewing angle
- High speed response
- SXGA(1280 x 1024 pixels) resolution
- Low power consumption
- 2 dual CCFTs(Cold Cathode Fluorescent Tube)
- DE only mode
- LVDS(Low Voltage Differential Signaling) interface (2pixels/clock)

### \* Applications

Workstation & desktop monitors

Display terminals for AV application products

Monitors for industrial machine

### \* General information

| Items             | Specification                | Unit   | Note |
|-------------------|------------------------------|--------|------|
| Display area      | 337.92(H) x 270.336(V)       | mm     |      |
| Driver element    | a-Si TFT active matrix       |        |      |
| Display colors    | 16.7M (true)                 | colors |      |
| Number of pixels  | 1280 x 1024                  | pixel  |      |
| Pixel arrangement | RGB vertical stripe          |        |      |
| Pixel pitch       | 0.264(H) x 0.264(W)          | mm     |      |
| Display mode      | Normally Black               |        |      |
| Surface treatment | Haze 44% , Hard-coating (3H) |        |      |

**\* Mechanical information**

| Item        |               | Min.  | Typ.  | Max.  | Note |
|-------------|---------------|-------|-------|-------|------|
| Module size | Horizontal(H) | 383.0 | 383.5 | 384.0 | mm   |
|             | Vertical(V)   | 305.5 | 306.0 | 306.5 | mm   |
|             | Depth(D)      | -     | -     | 22.8  | mm   |
| Weight      |               | -     | -     | 2,250 | g    |

**1. Absolute Maximum Ratings**

1.1 Absolute ratings of environment

| Item   | Symbol           | Min. | Max. | Unit | Note |
|--|------------------|------|------|------|------|
| Storage temperature                            | T <sub>STG</sub> | -30  | 70   | °C   | (1)  |
| Operating temperature<br>(Ambient temperature) | T <sub>OPR</sub> | 0    | 50   | °C   | (1)  |
| Shock ( non - operating )                      | Snop             | -    | 50   | G    | (2)  |
| Vibration ( non - operating )                  | Vnop             | -    | 1.5  | G    | (3)  |

Note (1) Temperature and relative humidity range are shown in the figure below.

90 % RH Max. ( 40 °C ≥ Ta )

Maximum wet-bulb temperature at 39 °C or less. (Ta > 40 °C) No condensation.

(2) 11ms, sine wave, one time for ±X, ±Y, ±Z axis

(3) 10-300 Hz, Sweep rate 10min, 30min for X,Y,Z axis

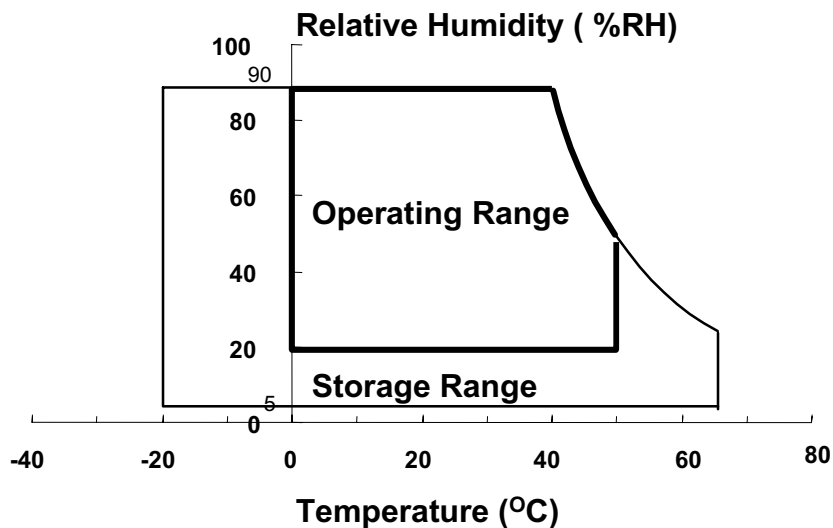

## 1.2 ELECTRICAL ABSOLUTE RATINGS

### (1) TFT LCD Module

(V<sub>SS</sub> = GND = 0 V)

| Item                 | Symbol | Min.                 | Max. | Unit | Note |
|----------------------|--------|----------------------|------|------|------|
| Power Supply Voltage | VDD    | V <sub>SS</sub> -0.5 | 6.5  | V    | (1)  |

NOTE (1) Within Ta ( 25 ± 2 °C)

### (2) BACK-LIGHT UNIT

(Ta = 25 ± 2°C)

| Item           | Symbol | Min. | Max. | Unit. | Note |
|----------------|--------|------|------|-------|------|
| Lamp Current   | IL     | 3.0  | 7.0  | mArms | (1)  |
| Lamp Frequency | fL     | 40   | 80   | kHz   |      |

NOTE (1) Specified values are for a single lamp.

## 2. Optical Characteristics

The following items are measured under stable conditions. The optical characteristics should be measured in a dark room or equivalent state with the methods shown in Note (1).

Measuring equipment : TOPCON BM-5A , BM-7, PHOTO RESEARCH PR650

(Inverter Freq. : 50kHz) \* Ta = 25 ± 2°C, VDD=5V, fv= 60Hz, fdCLK=54MHz, IL = 6.5mA<sub>rms</sub>

| Item                                     |         | Symbol     | Condition  | Min.  | Typ.          | Max.  | Unit          | Note              |              |
|--|---------|------------|--|-------|---------------|-------|---------------|-------------------|--------------|
| Contrast Ratio<br>(Center of screen)     |         | C/R        |  | 400   | 500           | -     |               | (3)<br>BM-5A      |              |
| Response<br>Time                         | Rising  | Tr         | Normal<br>$\phi = 0$<br>$\theta = 0$<br><br>Viewing<br>Angle | -     | 15            | 20    | msec          | (4)               |              |
|  | Falling | Tf         |  | -     | 10            | 15    |               | BM-7              |              |
| Luminance of White<br>(Center of screen) |         | YL         |  |       | 220           | 250   | -             | cd/m <sup>2</sup> | (5)<br>BM-5A |
| Color<br>Chromaticity<br>(CIE 1931)      | Red     | Rx         |  |       | TYP.<br>-0.03 | 0.634 | TYP.<br>+0.03 |                   | (6)<br>PR650 |
|  |         | Ry         |  | 0.354 |               |       |               |                   |              |
|  | Green   | Gx         |  | 0.304 |               |       |               |                   |              |
|  |         | Gy         |  | 0.581 |               |       |               |                   |              |
|  | Blue    | Bx         |  | 0.143 |               |       |               |                   |              |
|  |         | By         |  | 0.102 |               |       |               |                   |              |
|  | White   | Wx         |  | 0.310 |               |       |               |                   |              |
|  |         | Wy         |  | 0.330 |               |       |               |                   |              |
| Viewing<br>Angle                         | Hor.    | $\theta$ L | $CR \geq 10$   | 80    | 85            | -     | Degrees       | (1),(7)<br>BM-5A  |              |
|  |         | $\theta$ R |  | 80    | 85            | -     |               |                   |              |
|  | Ver.    | $\phi$ H   |  | 80    | 85            | -     |               |                   |              |
|  |         | $\phi$ L   |  | 80    | 85            | -     |               |                   |              |

Note 1) Test Equipment Setup

After stabilizing and leaving the panel alone at a given temperature for 30 min , the measurement should be executed. Measurement should be executed in a stable, windless, and dark room. 30 min after lighting the back-light. This should be measured in the center of screen.

Single lamp current : 6.5mA (Refer to the note(1) in the page 11 for more information.)

Environment condition :  $T_a = 25 \pm 2 \text{ } ^\circ\text{C}$

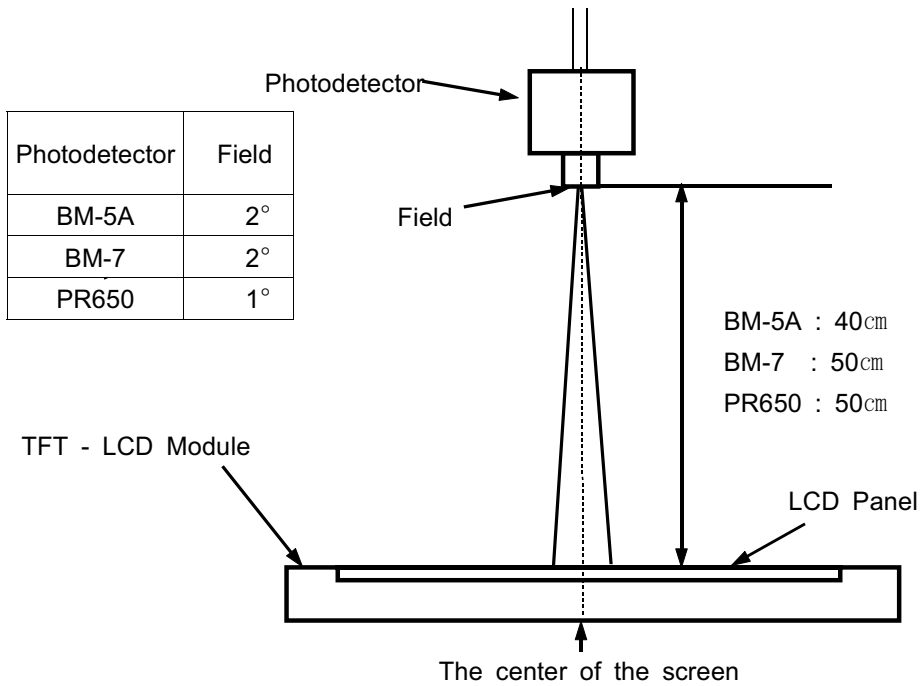

Optical Measuring Equipment Setup

Note 2) Definition of test point



Note 3) Definition of Contrast Ratio (C/R) : Ratio of gray max (Gmax) & gray min (Gmin) at the center point(5) of the panel

$$CR = \frac{G_{max}}{G_{min}}$$

Gmax : Luminance with all pixels white

Gmin : Luminance with all pixels black

Note 4) Definition of Response time : Sum of  $T_r$  ,  $T_f$

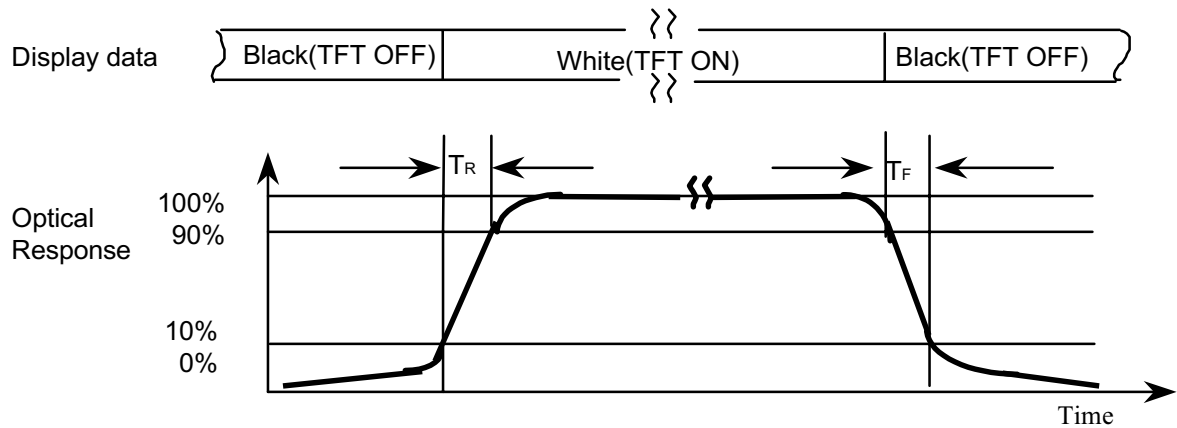

Note 5) Definition of Luminance of White : Luminance of white at center point(5).

Note 6) Definition of Color Chromaticity (CIE 1931)

Color coordinate of Red , Green , Blue & White at center point(5).

Note 7) Definition of Viewing Angle : Viewing angle range ( $CR \geq 10$  )

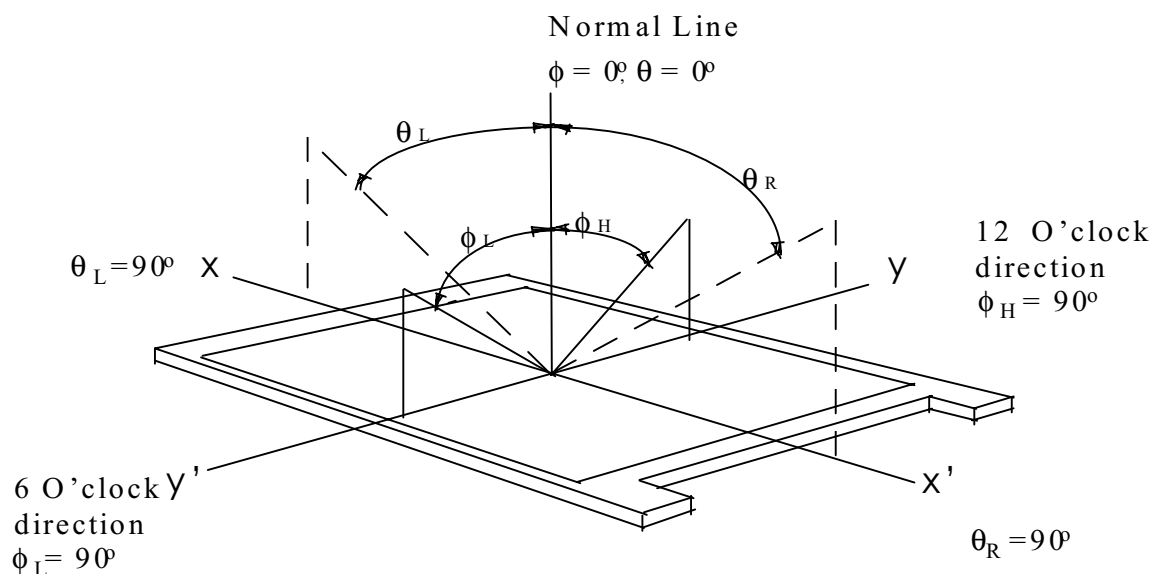



### 3. Electrical Characteristics

#### 3.1 TFT LCD MODULE

Ta = 25°C

| Item                    | Symbol            | Min.             | Typ. | Max.     | Unit | Note |         |
|-------------------------|-------------------|------------------|------|----------|------|------|---------|
| Voltage of Power Supply | V <sub>DD</sub>   | 4.5              | 5.0  | 5.5      | V    | (1)  |         |
| Interface type          | LVDS              | DS90C383/385/387 |      | DS90C386 | Pair |      |         |
| Current of Power Supply | (a)Black          | I <sub>DD</sub>  | -    | 600      | 800  | mA   | (2),(3) |
|                         | (b)White          |                  | -    | 700      | 1000 | mA   |         |
|                         | (c)2 Line Stripe  |                  | -    | 730      | 1000 | mA   |         |
| Vsync Frequency         | f <sub>V</sub>    | -                | 60   | 60       | Hz   |      |         |
| Hsync Frequency         | f <sub>H</sub>    | 62               | -    | 64       | kHz  |      |         |
| Main Frequency          | f <sub>DCLK</sub> | 40               | -    | 54       | MHz  |      |         |
| Rush Current            | I <sub>RUSH</sub> | -                | -    | 4.0      | A    | (4)  |         |

- Note
- (1) Display data should be connected with the connector for timing signal.(V<sub>SS</sub>=0)
  - (2) f<sub>V</sub>=60Hz, f<sub>DCLK</sub> =54MHz, V<sub>DD</sub> = 5.0V, DC Current.
  - (3) Power dissipation check pattern

a)Black Pattern

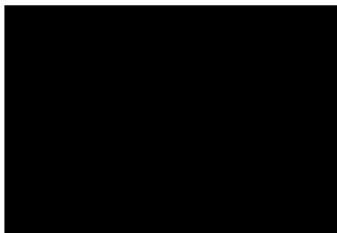

b)White Pattern

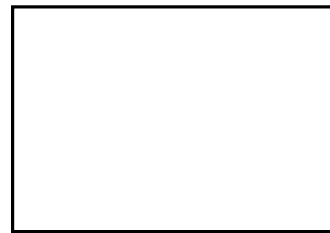

\*c) 2line Vertical stripe pattern

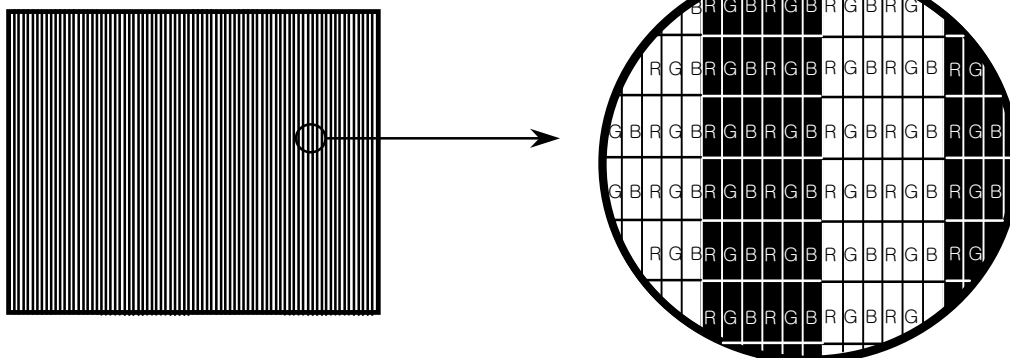

#### (4) Measurement Conditions

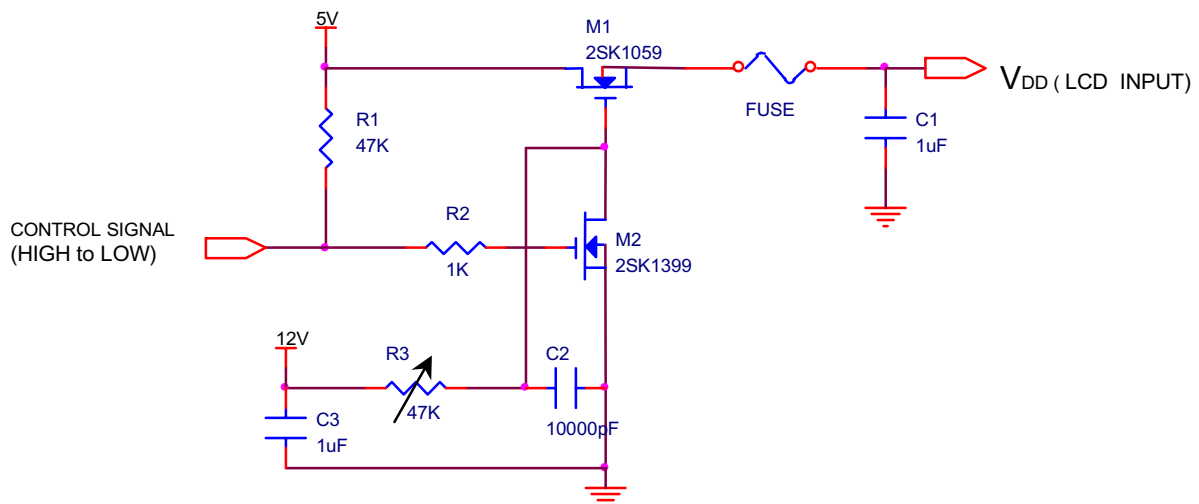

Note : Control Signal : High(+5V) -->Low(Ground)

All Signal lines to panel except for power 5V : Ground

The rising time of supplied voltage is controlled to 470us by R3 and C2 value.

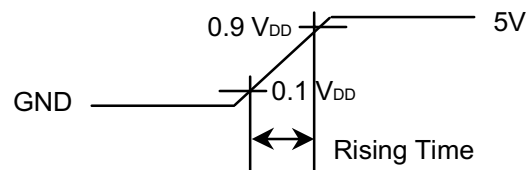

### 3.2 BACK-LIGHT UNIT

The back-light system is an edge - lighting type with 2 dual CCFTs ( Cold Cathode Fluorescent Tube ) The characteristics of two dual lamps are shown in the following tables.

Ta=25 ± 2°C

| Item            | Symbol | Min. | Typ. | Max.       | Unit  | Note |
|-----------------|--------|------|------|------------|-------|------|
| Lamp Current    | IL     | 3.0  | 6.5  | 7.0        | mArms | (1)  |
| Lamp Voltage    | VL     | -    | 700  | -          | Vrms  | (1)  |
| Lamp Frequency  | fL     | 40   | 60   | 70         | kHz   | (2)  |
| Startup Voltage | Vs     | -    | -    | 0°C:1,650  | Vrms  | (3)  |
|                 |        |      |      | 25°C:1,182 |       |      |

**Note) The waveform of the inverter output voltage must be area symmetric and the design of the inverter must have specifications for the modularized lamp.**

The performance of the back-light, for example life time or brightness, is much influenced by the characteristics of the DC-AC inverter for the lamp. So all the parameters of an inverter should be carefully designed so as not to produce too much leakage current from high-voltage output of the inverter.

When you design or order the inverter, please make sure that a poor lighting caused by the mismatch of the back-light and the inverter(miss lighting, flicker, etc.) never occur. When you confirm it, the module should be operated in the same condition as it is installed in your instrument.

Note (1) Lamp current is measured with current meter for high frequency as shown below.

Refer to the block diagram of the back-light unit in the next page for more information.

Specified values are for a single lamp.

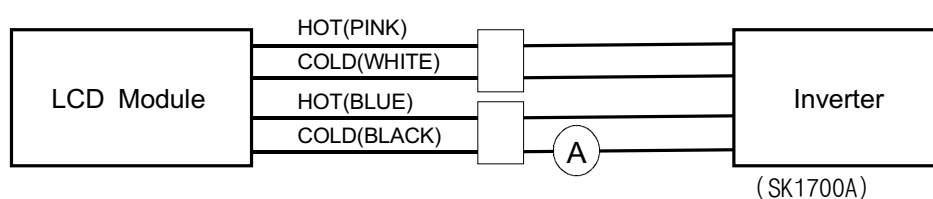

(2) Lamp frequency may produce interference with horizontal synchronous frequency and this may cause line flow on the display. Therefore lamp frequency shall be detached from the horizontal synchronous frequency and its harmonics as far as possible in order to avoid interference.

(3) Voltage higher than one manifested should be applied to the lamp for more than 1 second to start the lamp. Otherwise the lamp may not to be turned on.

## 4. Block Diagram

### 4.1 TFT LCD MODULE

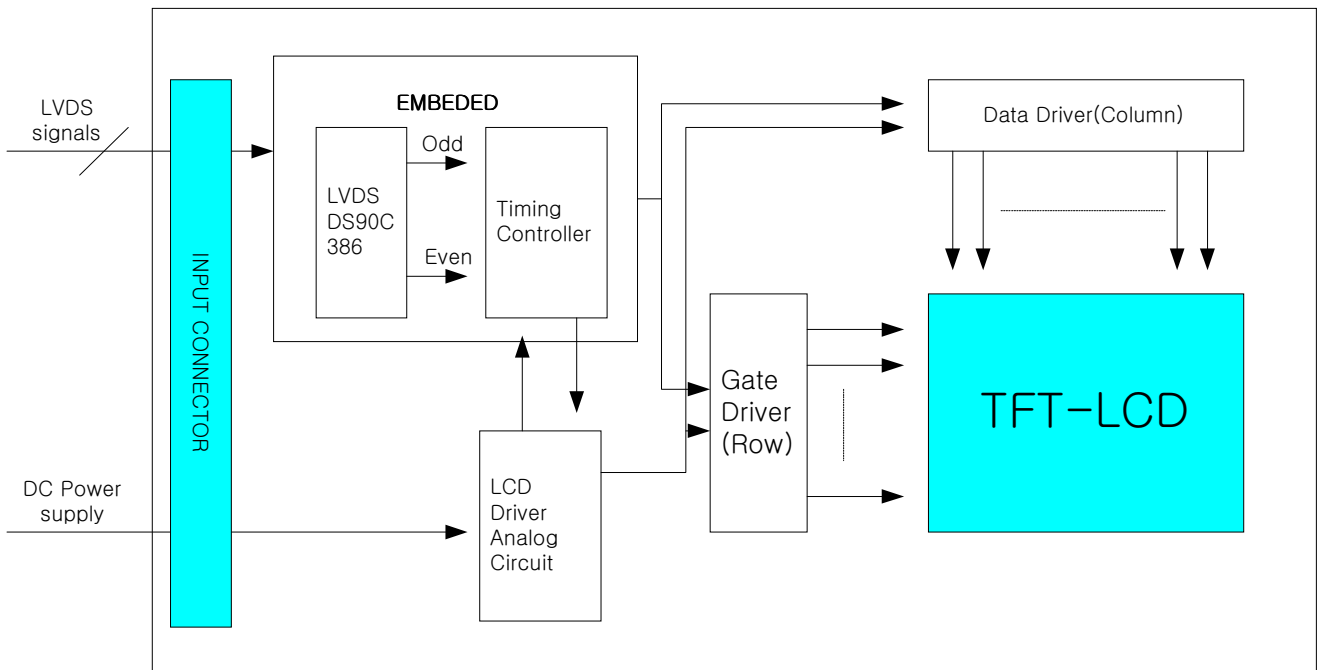

### 4.2 BACK-LIGHT UNIT

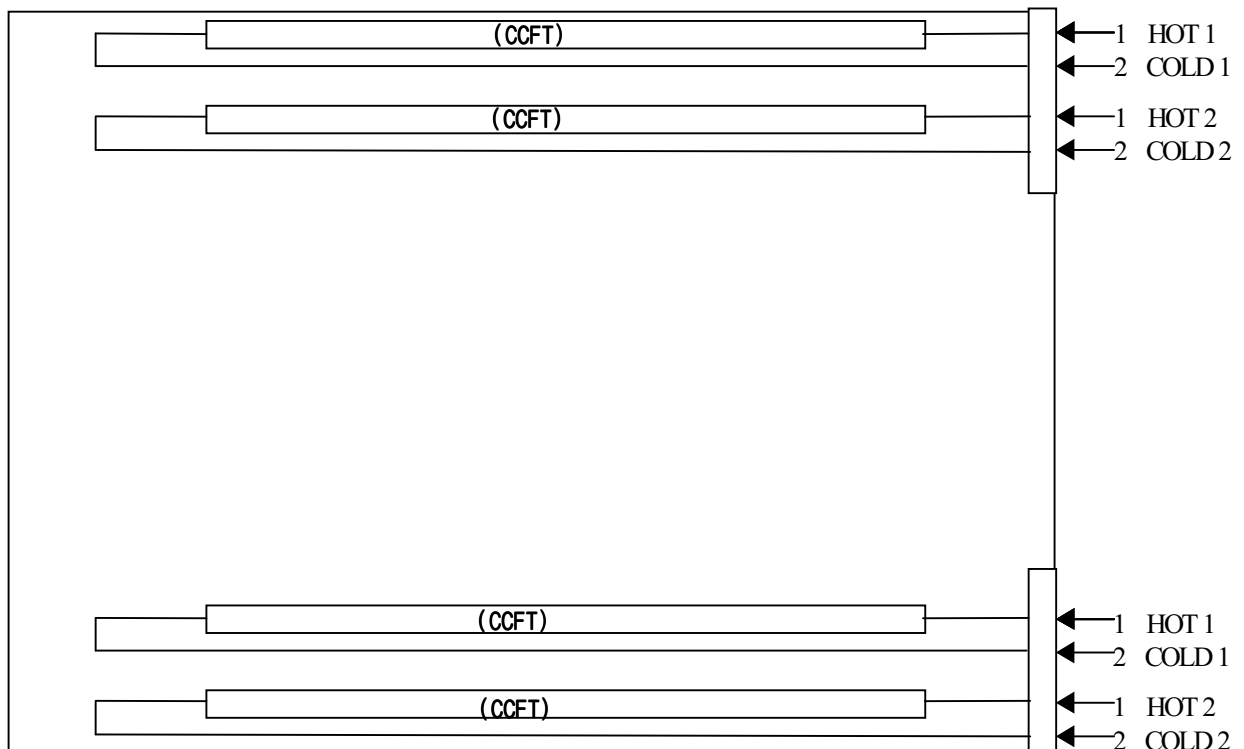

## 5. Input Terminal Pin Assignment

### 5.1. Input Signal & Power ( Connector : JAE FI-X30S-HF )

| PIN NO | SYMBOL          | FUNCTION  |
|--------|-----------------|---|
| 1      | RX00-           | Negative Transmission Data of Pixel 0 (ODD data)  |
| 2      | RX00+           | Positive Transmission Data of Pixel 0 (ODD data)  |
| 3      | RX01-           | Negative Transmission Data of Pixel 1 (ODD data)  |
| 4      | RX01+           | Positive Transmission Data of Pixel 1 (ODD data)  |
| 5      | RX02-           | Negative Transmission Data of Pixel 2 (ODD data)  |
| 6      | RX02+           | Positive Transmission Data of Pixel 2 (ODD data)  |
| 7      | GND             | Power Ground                                      |
| 8      | RXOC-           | Negative Sampling Clock (ODD data)                |
| 9      | RXOC+           | Positive Sampling Clock (ODD data)                |
| 10     | RX03-           | Negative Transmission Data of Pixel 3 (ODD data)  |
| 11     | RX03+           | Positive Transmission Data of Pixel 3 (ODD data)  |
| 12     | RXE0-           | Negative Transmission Data of Pixel 0 (EVEN data) |
| 13     | RXE0+           | Positive Transmission Data of Pixel 0 (EVEN data) |
| 14     | GND             | Power Ground                                      |
| 15     | RXE1-           | Negative Transmission Data of Pixel 1 (EVEN data) |
| 16     | RXE1+           | Positive Transmission Data of Pixel 1 (EVEN data) |
| 17     | GND             | Power Ground                                      |
| 18     | RXE2-           | Negative Transmission Data of Pixel 2 (EVEN data) |
| 19     | RXE2+           | Positive Transmission Data of Pixel 2 (EVEN data) |
| 20     | RXEC-           | Negative Sampling Clock (EVEN data)               |
| 21     | RXEC+           | Positive Sampling Clock (EVEN data)               |
| 22     | RXE3-           | Negative Transmission Data of Pixel 3 (EVEN data) |
| 23     | RXE3+           | Positive Transmission Data of Pixel 3 (EVEN data) |
| 24     | GND             | Power Ground                                      |
| 25     | NC              | No Connection                                     |
| 26     | DE              | DE Out  |
| 27     | NC              | No Connection                                     |
| 28     | V <sub>DD</sub> | Power Supply : +5V                                |
| 29     |                 |   |
| 30     |                 |   |

## 5.2 LVDS Interface(1)

-LVDS Receiver : Silicon Image SiI223

### 5.2.1 Odd pixel data (1st pixel data)

| 1st LVDS Transmitter ( <i>DS90C383</i> , <i>DS90C385</i> ) Signal Interface |        |                     |                            |                    |                                 |                |
|---|--------|---------------------|----------------------------|--------------------|---------------------------------|----------------|
| Device Input Pin  |        | Device Input Signal |                            | Output Signal      | To LTM170E4 Interface ( CN101 ) |                |
| No  | Symbol | Symbol              | Function                   |                    | Terminal                        | Symbol         |
| 51  | TXIN0  | RO0                 | Red Odd Pixel Data (LSB)   | TXOUT0-<br>TXOUT0+ | No. 1<br>No. 2                  | RXO0-<br>RXO0+ |
| 52  | TXIN1  | RO1                 | Red Odd Pixel Data         |                    |                                 |                |
| 54  | TXIN2  | RO2                 | Red Odd Pixel Data         |                    |                                 |                |
| 55  | TXIN3  | RO3                 | Red Odd Pixel Data         |                    |                                 |                |
| 56  | TXIN4  | RO4                 | Red Odd Pixel Data         |                    |                                 |                |
| 2   | TXIN5  | RO7                 | Red Odd Pixel Data (MSB)   | TXOUT3-<br>TXOUT3+ | No. 10<br>No. 11                | RXO3-<br>RXO3+ |
| 3   | TXIN6  | RO5                 | Red Odd Pixel Data         | TXOUT0-<br>TXOUT0+ | No. 1<br>No. 2                  | RXO0-<br>RXO0+ |
| 4   | TXIN7  | GO0                 | Green Odd Pixel Data (LSB) |                    |                                 |                |
| 6   | TXIN8  | GO1                 | Green Odd Pixel Data       | TXOUT1-<br>TXOUT1+ | No. 3<br>No. 4                  | RXO1-<br>RXO1+ |
| 7   | TXIN9  | GO2                 | Green Odd Pixel Data       |                    |                                 |                |
| 8   | TXIN10 | GO6                 | Green Odd Pixel Data       | TXOUT3-<br>TXOUT3+ | No. 10<br>No. 11                | RXO3-<br>RXO3+ |
| 10  | TXIN11 | GO7                 | Green Odd Pixel Data (MSB) |                    |                                 |                |
| 11  | TXIN12 | GO3                 | Green Odd Pixel Data       |                    |                                 |                |
| 12  | TXIN13 | GO4                 | Green Odd Pixel Data       | TXOUT1-<br>TXOUT1+ | No. 3<br>No. 4                  | RXO1-<br>RXO1+ |
| 14  | TXIN14 | GO5                 | Green Odd Pixel Data       |                    |                                 |                |
| 15  | TXIN15 | BO0                 | Blue Odd Pixel Data (LSB)  |                    |                                 |                |
| 16  | TXIN16 | BO6                 | Blue Odd Pixel Data        | TXOUT3-<br>TXOUT3+ | No. 10<br>No. 11                | RXO3-<br>RXO3+ |
| 18  | TXIN17 | BO7                 | Blue Odd Pixel Data (MSB)  |                    |                                 |                |
| 19  | TXIN18 | BO1                 | Blue Odd Pixel Data        | TXOUT1-<br>TXOUT1+ | No. 3<br>No. 4                  | RXO1-<br>RXO1+ |
| 20  | TXIN19 | BO2                 | Blue Odd Pixel Data        | TXOUT2-<br>TXOUT2+ | No. 5<br>No. 6                  | RXO2-<br>RXO2+ |
| 22  | TXIN20 | BO3                 | Blue Odd Pixel Data        |                    |                                 |                |
| 23  | TXIN21 | BO4                 | Blue Odd Pixel Data        |                    |                                 |                |
| 24  | TXIN22 | BO5                 | Blue Odd Pixel Data        |                    |                                 |                |
| 50  | TXIN27 | RO6                 | Red Odd Pixel Data         | TXOUT3-<br>TXOUT3+ | No. 10<br>No. 11                | RXO3-<br>RXO3+ |

### 5.2.2 Even pixel data (2nd pixel data)

| 2nd LVDS Transmitter ( <i>DS90C383</i> , <i>DS90C385</i> ) Signal Interface |        |                     |                             |                    |                                 |                |
|---|--------|---------------------|-----------------------------|--------------------|---------------------------------|----------------|
| Device Input Pin  |        | Device Input Signal |                             | Output Signal      | To LTM170E4 Interface ( CN101 ) |                |
| No  | Symbol | Symbol              | Function                    |                    | Terminal                        | Symbol         |
| 51  | TXIN0  | RE0                 | Red Even Pixel Data (LSB)   | TXOUT0-<br>TXOUT0+ | No. 12<br>No. 13                | RXE0-<br>RXE0+ |
| 52  | TXIN1  | RE1                 | Red Even Pixel Data         |                    |                                 |                |
| 54  | TXIN2  | RE2                 | Red Even Pixel Data         |                    |                                 |                |
| 55  | TXIN3  | RE3                 | Red Even Pixel Data         |                    |                                 |                |
| 56  | TXIN4  | RE4                 | Red Even Pixel Data         |                    |                                 |                |
| 2   | TXIN5  | RE7                 | Red Even Pixel Data (MSB)   | TXOUT3-<br>TXOUT3+ | No. 22<br>No. 23                | RXE3-<br>RXE3+ |
| 3   | TXIN6  | RE5                 | Red Even Pixel Data         | TXOUT0-<br>TXOUT0+ | No. 12<br>No. 13                | RXE0-<br>RXE0+ |
| 4   | TXIN7  | GE0                 | Green Even Pixel Data (LSB) |                    |                                 |                |
| 6   | TXIN8  | GE1                 | Green Even Pixel Data       | TXOUT1-<br>TXOUT1+ | No. 15<br>No. 16                | RXE1-<br>RXE1+ |
| 7   | TXIN9  | GE2                 | Green Even Pixel Data       |                    |                                 |                |
| 8   | TXIN10 | GE6                 | Green Even Pixel Data       | TXOUT3-<br>TXOUT3+ | No. 22<br>No. 23                | RXE3-<br>RXE3+ |
| 10  | TXIN11 | GE7                 | Green Even Pixel Data (MSB) |                    |                                 |                |
| 11  | TXIN12 | GE3                 | Green Even Pixel Data       | TXOUT1-<br>TXOUT1+ | No. 15<br>No. 16                | RXE1-<br>RXE1+ |
| 12  | TXIN13 | GE4                 | Green Even Pixel Data       |                    |                                 |                |
| 14  | TXIN14 | GE5                 | Green Even Pixel Data       |                    |                                 |                |
| 15  | TXIN15 | BE0                 | Blue Even Pixel Data (LSB)  | TXOUT3-<br>TXOUT3+ | No. 22<br>No. 23                | RXE3-<br>RXE3+ |
| 16  | TXIN16 | BE6                 | Blue Even Pixel Data        |                    |                                 |                |
| 18  | TXIN17 | BE7                 | Blue Even Pixel Data (MSB)  |                    |                                 |                |
| 19  | TXIN18 | BE1                 | Blue Even Pixel Data        | TXOUT1-<br>TXOUT1+ | No. 15<br>No. 16                | RXE1-<br>RXE1+ |
| 20  | TXIN19 | BE2                 | Blue Even Pixel Data        | TXOUT2-<br>TXOUT2+ | No. 18<br>No. 19                | RXE2-<br>RXE2+ |
| 22  | TXIN20 | BE3                 | Blue Even Pixel Data        |                    |                                 |                |
| 23  | TXIN21 | BE4                 | Blue Even Pixel Data        |                    |                                 |                |
| 24  | TXIN22 | BE5                 | Blue Even Pixel Data        |                    |                                 |                |
| 50  | TXIN27 | RE6                 | Red Even Pixel Data         | TXOUT3-<br>TXOUT3+ | No. 22<br>No. 23                | RXE3-<br>RXE3+ |

### 5.3 LVDS Interface (2)

-LVDS Receiver : Silicon Image SiI223

#### 5.3.1 Odd pixel data (1st pixel data)

| LVDS Transmitter ( <i>DS90C387</i> ) Signal Interface |        |                     |                            |               |                                 |                |
|---|--------|---------------------|----------------------------|---------------|---------------------------------|----------------|
| Device Input Pin                                      |        | Device Input Signal |                            | Output Signal | To LTM170E4 Interface ( CN101 ) |                |
| No  | Symbol | Symbol              | Function                   |               | Terminal                        | Symbol         |
| 10  | R10    | RO0                 | Red Odd Pixel Data (LSB)   | A0M<br>A0P    | No. 1                           | RXO0-<br>RXO0+ |
| 9   | R11    | RO1                 | Red Odd Pixel Data         |               |                                 |                |
| 8   | R12    | RO2                 | Red Odd Pixel Data         |               |                                 |                |
| 7   | R13    | RO3                 | Red Odd Pixel Data         |               |                                 |                |
| 6   | R14    | RO4                 | Red Odd Pixel Data         |               |                                 |                |
| 3   | R17    | RO7                 | Red Odd Pixel Data (MSB)   | A3M<br>A3P    | No. 10<br>No. 11                | RXO3-<br>RXO3+ |
| 5   | R15    | RO5                 | Red Odd Pixel Data         | A0M<br>A0P    | No. 1<br>No. 2                  | RXO0-<br>RXO0+ |
| 2   | G10    | GO0                 | Green Odd Pixel Data (LSB) |               |                                 |                |
| 1   | G11    | GO1                 | Green Odd Pixel Data       | A1M<br>A1P    | No. 3<br>No. 4                  | RXO1-<br>RXO1+ |
| 100   | G12    | GO2                 | Green Odd Pixel Data       |               |                                 |                |
| 94  | G16    | GO6                 | Green Odd Pixel Data       | A3M<br>A3P    | No. 10<br>No. 11                | RXO3-<br>RXO3+ |
| 93  | G17    | GO7                 | Green Odd Pixel Data (MSB) |               |                                 |                |
| 99  | G13    | GO3                 | Green Odd Pixel Data       | A1M<br>A1P    | No. 3<br>No. 4                  | RXO1-<br>RXO1+ |
| 96  | G14    | GO4                 | Green Odd Pixel Data       |               |                                 |                |
| 95  | G15    | GO5                 | Green Odd Pixel Data       |               |                                 |                |
| 92  | B10    | BO0                 | Blue Odd Pixel Data (LSB)  | A3M<br>A3P    | No. 10<br>No. 11                | RXO3-<br>RXO3+ |
| 86  | B16    | BO6                 | Blue Odd Pixel Data        |               |                                 |                |
| 85  | B17    | BO7                 | Blue Odd Pixel Data (MSB)  |               |                                 |                |
| 91  | B11    | BO1                 | Blue Odd Pixel Data        | A1M<br>A1P    | No. 3<br>No. 4                  | RXO1-<br>RXO1+ |
| 90  | B12    | BO2                 | Blue Odd Pixel Data        | A2M<br>A2P    | No. 5<br>No. 6                  | RXO2-<br>RXO2+ |
| 89  | B13    | BO3                 | Blue Odd Pixel Data        |               |                                 |                |
| 88  | B14    | BO4                 | Blue Odd Pixel Data        |               |                                 |                |
| 87  | B15    | BO5                 | Blue Odd Pixel Data        | A3M<br>A3P    | No. 10<br>No. 11                | RXO3-<br>RXO3+ |
| 4   | R16    | RO6                 | Red Odd Pixel Data         |               |                                 |                |



### 5.3.2 Even pixel data (2nd pixel data)

| LVDS Transmitter ( <i>DS90C387</i> ) Signal Interface |        |                     |                             |               |                                 |                |
|---|--------|---------------------|-----------------------------|---------------|---------------------------------|----------------|
| Device Input Pin                                      |        | Device Input Signal |                             | Output Signal | To LTM170E4 Interface ( CN101 ) |                |
| No  | Symbol | Symbol              | Function                    |               | Terminal                        | Symbol         |
| 84  | R20    | RE0                 | Red Even Pixel Data (LSB)   | A4M<br>A4P    | No. 12<br>No. 13                | RXE0-<br>RXE0+ |
| 81  | R21    | RE1                 | Red Even Pixel Data         |               |                                 |                |
| 80  | R22    | RE2                 | Red Even Pixel Data         |               |                                 |                |
| 79  | R23    | RE3                 | Red Even Pixel Data         |               |                                 |                |
| 78  | R24    | RE4                 | Red Even Pixel Data         |               |                                 |                |
| 75  | R27    | RE7                 | Red Even Pixel Data (MSB)   | A7M<br>A7P    | No. 22<br>No. 23                | RXE3-<br>RXE3+ |
| 77  | R25    | RE5                 | Red Even Pixel Data         | A4M<br>A4P    | No. 12<br>No. 13                | RXE0-<br>RXE0+ |
| 74  | G20    | GE0                 | Green Even Pixel Data (LSB) |               |                                 |                |
| 73  | G21    | GE1                 | Green Even Pixel Data       | A5M<br>A5P    | No. 15<br>No. 16                | RXE1-<br>RXE1+ |
| 72  | G22    | GE2                 | Green Even Pixel Data       |               |                                 |                |
| 66  | G26    | GE6                 | Green Even Pixel Data       | A7M<br>A7P    | No. 22<br>No. 23                | RXE3-<br>RXE3+ |
| 65  | G27    | GE7                 | Green Even Pixel Data (MSB) |               |                                 |                |
| 71  | G23    | GE3                 | Green Even Pixel Data       | A5M<br>A5P    | No. 15<br>No. 16                | RXE1-<br>RXE1+ |
| 70  | G24    | GE4                 | Green Even Pixel Data       |               |                                 |                |
| 69  | G25    | GE5                 | Green Even Pixel Data       |               |                                 |                |
| 64  | B20    | BE0                 | Blue Even Pixel Data (LSB)  | A7M<br>A7P    | No. 22<br>No. 23                | RXE3-<br>RXE3+ |
| 58  | B26    | BE6                 | Blue Even Pixel Data        |               |                                 |                |
| 57  | B27    | BE7                 | Blue Even Pixel Data (MSB)  |               |                                 |                |
| 63  | B21    | BE1                 | Blue Even Pixel Data        | A5M<br>A5P    | No. 15<br>No. 16                | RXE1-<br>RXE1+ |
| 62  | B22    | BE2                 | Blue Even Pixel Data        |               |                                 |                |
| 61  | B23    | BE3                 | Blue Even Pixel Data        | A6M<br>A6P    | No. 18<br>No. 19                | RXE2-<br>RXE2+ |
| 60  | B24    | BE4                 | Blue Even Pixel Data        |               |                                 |                |
| 59  | B25    | BE5                 | Blue Even Pixel Data        |               |                                 |                |
| 76  | R26    | RE6                 | Red Even Pixel Data         | A7M<br>A7P    | No. 22<br>No. 23                | RXE3-<br>RXE3+ |

NOTE)

Must be connected 24th BAL pin with low and 23th DUAL pin with high in DS90C387 LVDS Transmitter

#### 5.4 BACK-LIGHT UNIT

| Pin No.               | Input [ch1] ,[ch2] | Color | Fucntion     |
|-----------------------|--------------------|-------|--------------|
| 1                     | Hot1               | Pink  | High Voltage |
| 2                     | Cold1              | White | Ground       |
| 3                     | Hot2               | Blue  | High Voltage |
| 4                     | Cold2              | Black | Ground       |
| Connector<br>Part No. | JST BHSR-02VS-1    |       |              |

### 5.5 Input Signal, Basic Display Colors and Gray Scale of Each Colors

| COLOR               | DISPLAY | DATA SIGNAL |    |    |    |    |    |    |       |    |    |    |    |    |    |      |    |    |    |    |    |    |    |    |    |   |   |   |   | GRAY SCALE LEVEL |   |   |   |   |   |   |   |   |      |         |         |
|---------------------|---------|-------------|----|----|----|----|----|----|-------|----|----|----|----|----|----|------|----|----|----|----|----|----|----|----|----|---|---|---|---|------------------|---|---|---|---|---|---|---|---|------|---------|---------|
|                     |         | RED         |    |    |    |    |    |    | GREEN |    |    |    |    |    |    | BLUE |    |    |    |    |    |    |    |    |    |   |   |   |   |                  |   |   |   |   |   |   |   |   |      |         |         |
|                     |         | R0          | R1 | R2 | R3 | R4 | R5 | R6 | R7    | G0 | G1 | G2 | G3 | G4 | G5 | G6   | G7 | B0 | B1 | B2 | B3 | B4 | B5 | B6 | B7 |   |   |   |   |                  |   |   |   |   |   |   |   |   |      |         |         |
| BASIC COLOR         | BLACK   | 0           | 0  | 0  | 0  | 0  | 0  | 0  | 0     | 0  | 0  | 0  | 0  | 0  | 0  | 0    | 0  | 0  | 0  | 0  | 0  | 0  | 0  | 0  | 0  | 0 | 0 | 0 | 0 | 0                | 0 | 0 | 0 | 0 | 0 | 0 | 0 | 0 | -    |         |         |
|                     | BLUE    | 0           | 0  | 0  | 0  | 0  | 0  | 0  | 0     | 0  | 0  | 0  | 0  | 0  | 0  | 0    | 0  | 0  | 1  | 1  | 1  | 1  | 1  | 1  | 1  | 1 | 1 | 1 | 1 | 1                | 1 | 1 | 1 | 1 | 1 | 1 | 1 | 1 | 1    | -       |         |
|                     | GREEN   | 0           | 0  | 0  | 0  | 0  | 0  | 0  | 0     | 1  | 1  | 1  | 1  | 1  | 1  | 1    | 1  | 1  | 0  | 0  | 0  | 0  | 0  | 0  | 0  | 0 | 0 | 0 | 0 | 0                | 0 | 0 | 0 | 0 | 0 | 0 | 0 | 0 | 0    | -       |         |
|                     | CYAN    | 0           | 0  | 0  | 0  | 0  | 0  | 0  | 0     | 1  | 1  | 1  | 1  | 1  | 1  | 1    | 1  | 1  | 1  | 1  | 1  | 1  | 1  | 1  | 1  | 1 | 1 | 1 | 1 | 1                | 1 | 1 | 1 | 1 | 1 | 1 | 1 | 1 | 1    | -       |         |
|                     | RED     | 1           | 1  | 1  | 1  | 1  | 1  | 1  | 1     | 0  | 0  | 0  | 0  | 0  | 0  | 0    | 0  | 0  | 0  | 0  | 0  | 0  | 0  | 0  | 0  | 0 | 0 | 0 | 0 | 0                | 0 | 0 | 0 | 0 | 0 | 0 | 0 | 0 | 0    | -       |         |
|                     | MAGENTA | 1           | 1  | 1  | 1  | 1  | 1  | 1  | 1     | 0  | 0  | 0  | 0  | 0  | 0  | 0    | 0  | 0  | 1  | 1  | 1  | 1  | 1  | 1  | 1  | 1 | 1 | 1 | 1 | 1                | 1 | 1 | 1 | 1 | 1 | 1 | 1 | 1 | 1    | -       |         |
|                     | YELLOW  | 1           | 1  | 1  | 1  | 1  | 1  | 1  | 1     | 1  | 1  | 1  | 1  | 1  | 1  | 1    | 1  | 1  | 0  | 0  | 0  | 0  | 0  | 0  | 0  | 0 | 0 | 0 | 0 | 0                | 0 | 0 | 0 | 0 | 0 | 0 | 0 | 0 | 0    | -       |         |
|                     | WHITE   | 1           | 1  | 1  | 1  | 1  | 1  | 1  | 1     | 1  | 1  | 1  | 1  | 1  | 1  | 1    | 1  | 1  | 1  | 1  | 1  | 1  | 1  | 1  | 1  | 1 | 1 | 1 | 1 | 1                | 1 | 1 | 1 | 1 | 1 | 1 | 1 | 1 | 1    | -       |         |
| GRAY SCALE OF RED   | BLACK   | 0           | 0  | 0  | 0  | 0  | 0  | 0  | 0     | 0  | 0  | 0  | 0  | 0  | 0  | 0    | 0  | 0  | 0  | 0  | 0  | 0  | 0  | 0  | 0  | 0 | 0 | 0 | 0 | 0                | 0 | 0 | 0 | 0 | 0 | 0 | 0 | 0 | R0   |         |         |
|                     | DARK ↑  | 0           | 0  | 0  | 0  | 0  | 0  | 0  | 0     | 0  | 0  | 0  | 0  | 0  | 0  | 0    | 0  | 0  | 0  | 0  | 0  | 0  | 0  | 0  | 0  | 0 | 0 | 0 | 0 | 0                | 0 | 0 | 0 | 0 | 0 | 0 | 0 | 0 | R1   |         |         |
|                     |         | 0           | 1  | 0  | 0  | 0  | 0  | 0  | 0     | 0  | 0  | 0  | 0  | 0  | 0  | 0    | 0  | 0  | 0  | 0  | 0  | 0  | 0  | 0  | 0  | 0 | 0 | 0 | 0 | 0                | 0 | 0 | 0 | 0 | 0 | 0 | 0 | 0 | R2   |         |         |
|                     | ↓       | :           | :  | :  | :  | :  | :  | :  | :     | :  | :  | :  | :  | :  | :  | :    | :  | :  | :  | :  | :  | :  | :  | :  | :  | : | : | : | : | :                | : | : | : | : | : | : | : | : | :    | R3-R252 |         |
|                     |         | :           | :  | :  | :  | :  | :  | :  | :     | :  | :  | :  | :  | :  | :  | :    | :  | :  | :  | :  | :  | :  | :  | :  | :  | : | : | : | : | :                | : | : | : | : | : | : | : | : | :    | R253    |         |
|                     |         | 1           | 0  | 1  | 1  | 1  | 1  | 1  | 1     | 0  | 0  | 0  | 0  | 0  | 0  | 0    | 0  | 0  | 0  | 0  | 0  | 0  | 0  | 0  | 0  | 0 | 0 | 0 | 0 | 0                | 0 | 0 | 0 | 0 | 0 | 0 | 0 | 0 | R254 |         |         |
|                     | LIGHT   | 0           | 1  | 1  | 1  | 1  | 1  | 1  | 1     | 0  | 0  | 0  | 0  | 0  | 0  | 0    | 0  | 0  | 0  | 0  | 0  | 0  | 0  | 0  | 0  | 0 | 0 | 0 | 0 | 0                | 0 | 0 | 0 | 0 | 0 | 0 | 0 | 0 | 0    | R255    |         |
| RED                 | 1       | 1           | 1  | 1  | 1  | 1  | 1  | 1  | 0     | 0  | 0  | 0  | 0  | 0  | 0  | 0    | 0  | 0  | 0  | 0  | 0  | 0  | 0  | 0  | 0  | 0 | 0 | 0 | 0 | 0                | 0 | 0 | 0 | 0 | 0 | 0 | 0 | 0 | 0    | R255    |         |
| GRAY SCALE OF GREEN | BLACK   | 0           | 0  | 0  | 0  | 0  | 0  | 0  | 0     | 0  | 0  | 0  | 0  | 0  | 0  | 0    | 0  | 0  | 0  | 0  | 0  | 0  | 0  | 0  | 0  | 0 | 0 | 0 | 0 | 0                | 0 | 0 | 0 | 0 | 0 | 0 | 0 | 0 | 0    | G0      |         |
|                     | DARK ↑  | 0           | 0  | 0  | 0  | 0  | 0  | 0  | 0     | 1  | 0  | 0  | 0  | 0  | 0  | 0    | 0  | 0  | 0  | 0  | 0  | 0  | 0  | 0  | 0  | 0 | 0 | 0 | 0 | 0                | 0 | 0 | 0 | 0 | 0 | 0 | 0 | 0 | 0    | G1      |         |
|                     |         | 0           | 0  | 0  | 0  | 0  | 0  | 0  | 0     | 0  | 1  | 0  | 0  | 0  | 0  | 0    | 0  | 0  | 0  | 0  | 0  | 0  | 0  | 0  | 0  | 0 | 0 | 0 | 0 | 0                | 0 | 0 | 0 | 0 | 0 | 0 | 0 | 0 | 0    | G2      |         |
|                     | ↓       | :           | :  | :  | :  | :  | :  | :  | :     | :  | :  | :  | :  | :  | :  | :    | :  | :  | :  | :  | :  | :  | :  | :  | :  | : | : | : | : | :                | : | : | : | : | : | : | : | : | :    | :       | G3-G252 |
|                     |         | :           | :  | :  | :  | :  | :  | :  | :     | :  | :  | :  | :  | :  | :  | :    | :  | :  | :  | :  | :  | :  | :  | :  | :  | : | : | : | : | :                | : | : | : | : | : | : | : | : | :    | G253    |         |
|                     |         | 0           | 0  | 0  | 0  | 0  | 0  | 0  | 0     | 1  | 0  | 1  | 1  | 1  | 1  | 1    | 1  | 1  | 0  | 0  | 0  | 0  | 0  | 0  | 0  | 0 | 0 | 0 | 0 | 0                | 0 | 0 | 0 | 0 | 0 | 0 | 0 | 0 | 0    | G254    |         |
|                     | LIGHT   | 0           | 0  | 0  | 0  | 0  | 0  | 0  | 0     | 1  | 1  | 1  | 1  | 1  | 1  | 1    | 1  | 0  | 0  | 0  | 0  | 0  | 0  | 0  | 0  | 0 | 0 | 0 | 0 | 0                | 0 | 0 | 0 | 0 | 0 | 0 | 0 | 0 | 0    | G255    |         |
| GREEN               | 0       | 0           | 0  | 0  | 0  | 0  | 0  | 0  | 1     | 1  | 1  | 1  | 1  | 1  | 1  | 1    | 0  | 0  | 0  | 0  | 0  | 0  | 0  | 0  | 0  | 0 | 0 | 0 | 0 | 0                | 0 | 0 | 0 | 0 | 0 | 0 | 0 | 0 | G255 |         |         |
| GRAY SCALE OF BLUE  | BLACK   | 0           | 0  | 0  | 0  | 0  | 0  | 0  | 0     | 0  | 0  | 0  | 0  | 0  | 0  | 0    | 0  | 0  | 0  | 0  | 0  | 0  | 0  | 0  | 0  | 0 | 0 | 0 | 0 | 0                | 0 | 0 | 0 | 0 | 0 | 0 | 0 | 0 | 0    | B0      |         |
|                     | DARK ↑  | 0           | 0  | 0  | 0  | 0  | 0  | 0  | 0     | 0  | 0  | 0  | 0  | 0  | 0  | 0    | 0  | 0  | 1  | 0  | 0  | 0  | 0  | 0  | 0  | 0 | 0 | 0 | 0 | 0                | 0 | 0 | 0 | 0 | 0 | 0 | 0 | 0 | 0    | B1      |         |
|                     |         | 0           | 0  | 0  | 0  | 0  | 0  | 0  | 0     | 0  | 0  | 0  | 0  | 0  | 0  | 0    | 0  | 0  | 0  | 1  | 0  | 0  | 0  | 0  | 0  | 0 | 0 | 0 | 0 | 0                | 0 | 0 | 0 | 0 | 0 | 0 | 0 | 0 | 0    | B2      |         |
|                     | ↓       | :           | :  | :  | :  | :  | :  | :  | :     | :  | :  | :  | :  | :  | :  | :    | :  | :  | :  | :  | :  | :  | :  | :  | :  | : | : | : | : | :                | : | : | : | : | : | : | : | : | :    | :       | B3-B252 |
|                     |         | :           | :  | :  | :  | :  | :  | :  | :     | :  | :  | :  | :  | :  | :  | :    | :  | :  | :  | :  | :  | :  | :  | :  | :  | : | : | : | : | :                | : | : | : | : | : | : | : | : | :    | B253    |         |
|                     |         | 0           | 0  | 0  | 0  | 0  | 0  | 0  | 0     | 0  | 0  | 0  | 0  | 0  | 0  | 0    | 0  | 0  | 1  | 0  | 1  | 1  | 1  | 1  | 1  | 1 | 1 | 1 | 1 | 1                | 1 | 1 | 1 | 1 | 1 | 1 | 1 | 1 | 1    | B254    |         |
|                     | LIGHT   | 0           | 0  | 0  | 0  | 0  | 0  | 0  | 0     | 0  | 0  | 0  | 0  | 0  | 0  | 0    | 0  | 0  | 1  | 1  | 1  | 1  | 1  | 1  | 1  | 1 | 1 | 1 | 1 | 1                | 1 | 1 | 1 | 1 | 1 | 1 | 1 | 1 | 1    | B255    |         |
| BLUE                | 0       | 0           | 0  | 0  | 0  | 0  | 0  | 0  | 0     | 0  | 0  | 0  | 0  | 0  | 0  | 0    | 0  | 1  | 1  | 1  | 1  | 1  | 1  | 1  | 1  | 1 | 1 | 1 | 1 | 1                | 1 | 1 | 1 | 1 | 1 | 1 | 1 | 1 | B255 |         |         |

Note) Definition of Gray :

Rn : Red Gray, Gn : Green Gray, Bn : Blue Gray (n = Gray level)

Input Signal : 0 = Low level voltage, 1 = High level voltage

## 6. Interface Timing

### 6.1 Timing Parameters ( DE only mode )

2pixel/clock

| Signal                         | Item                  | Symbol | Min. | Typ. | Max. | Unit   | Note |
|--------------------------------|-----------------------|--------|------|------|------|--------|------|
| Clock                          | Frequency             | 1/TC   | 42   | -    | 54   | MHz    | (2)  |
|                                | High Time             | TCH    | 4    | -    | -    | nsec   |      |
|                                | Low Time              | TCL    | 4    | -    | -    | nsec   |      |
| Data                           | Setup Time            | TDS    | 4    | -    | -    | nsec   |      |
|                                | Hold Time             | TDH    | 4    | -    | -    | nsec   |      |
| Data Enable                    | Setup Time            | TES    | 4    | -    | -    | nsec   | (1)  |
| Frame Frequency                | Cycle                 | TV     | -    | 16.7 | 16.7 | msec   |      |
|                                |                       |        | 1032 | 1066 | 1066 | lines  |      |
| Vertical Active Display Term   | Display Period        | TVD    | 1024 | 1024 | 1024 | lines  |      |
|                                | Vertical Blank Period | TVB    | 8    | -    | -    | lines  |      |
| One Line Scanning Time         | Cycle                 | TH     | 672  | -    | 844  | clocks |      |
| Horizontal Active Display Term | Display Period        | THD    | 640  | 640  | 640  | clocks |      |

Note (1) Test Point : TTL control signal and CLK at LVDS Tx input terminal in system

(2) Internal Vcc = 3.0V

6.2 Timing diagrams of interface signal ( DE only mode )

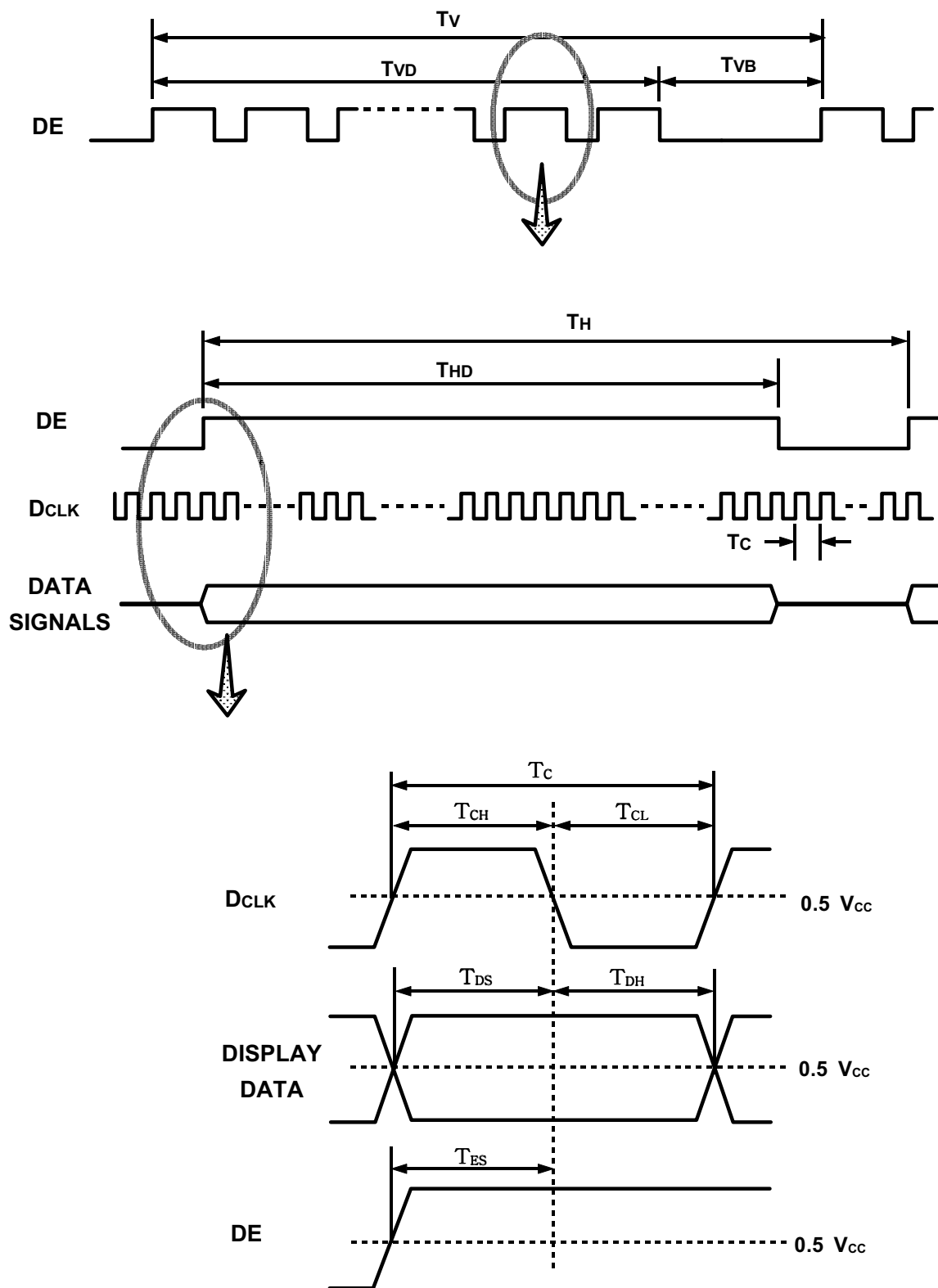

### 6.3 Power ON/OFF Sequence

: To prevent a latch-up or DC operation of the LCD module, the power on/off sequence should be as the diagram below.

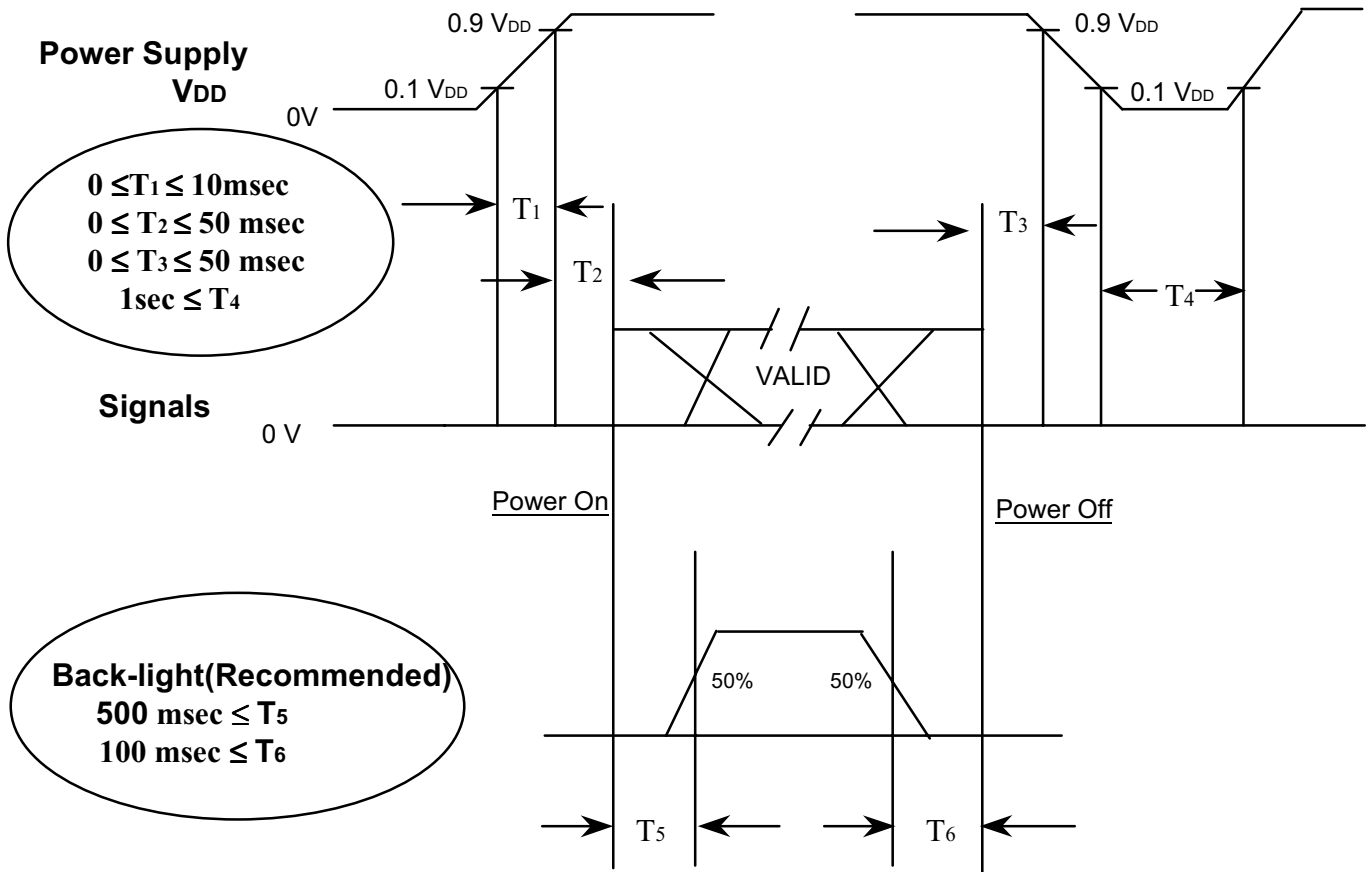

Power ON/OFF Sequence

#### NOTE.

- (1) The supply voltage of the external system for the module input should be the same as the definition of VDD.
- (2) Apply the lamp voltage within the LCD operation range. When the back-light turns on before the LCD operation or the LCD turns off before the back-light turns off, the display may momentarily become abnormal screen.
- (3) In case of VDD = off level, please keep the level of input signals on the low or keep a high impedance.
- (4) T<sub>4</sub> should be measured after the module has been fully discharged between power off and on period.
- (5) Interface signal shall not be kept at high impedance when the power is on.

## **7. Outline Dimension**

**Refer to the next page.**

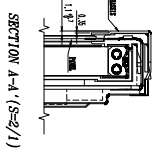
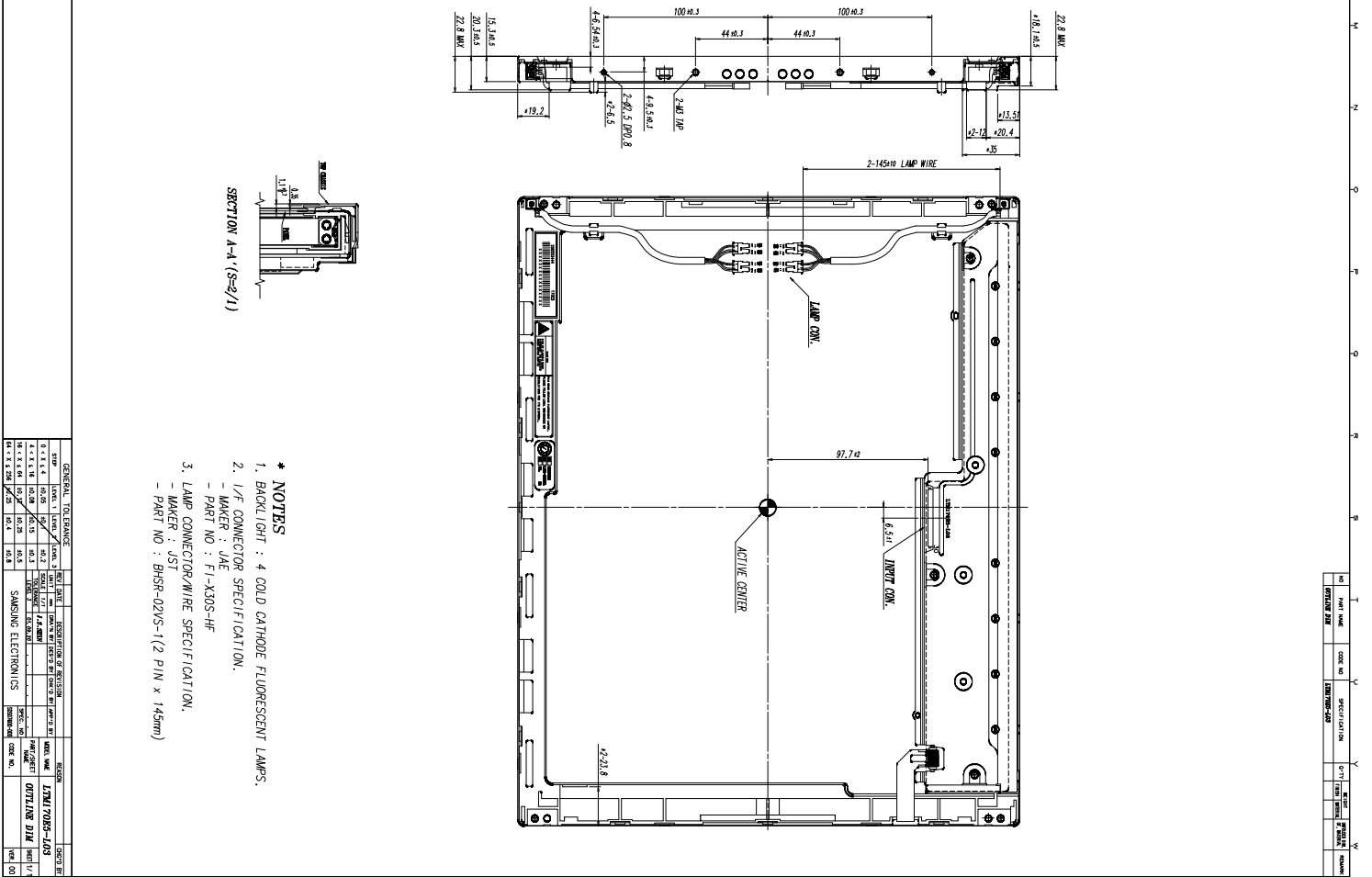
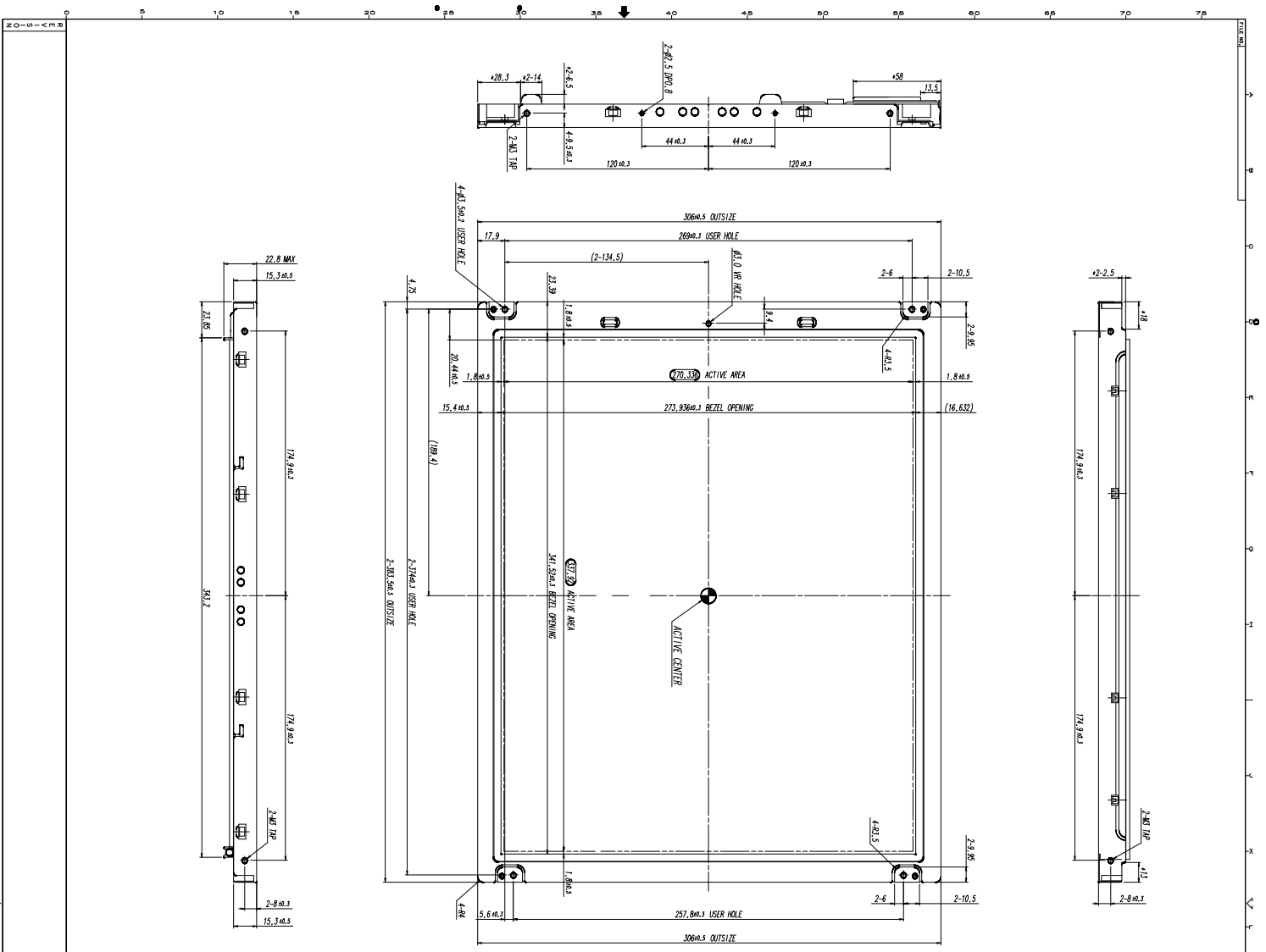

- \* NOTES**
1. BACKLIGHT : 4 COLD CATHODE FLUORESCENT LAMPS.
  2. I/F CONNECTOR SPECIFICATION.  
 - MAKER : LAE  
 - PART NO : FI-X305-HF
  3. LAMP CONNECTOR/WIRE SPECIFICATION.  
 - MAKER : JST  
 - PART NO : BHSR-02/S-(2 PIN x 145mm)

| REV | DATE     | DESCRIPTION    | BY | CHK | APP |
|-----|----------|----------------|----|-----|-----|
| 01  | 15.05.20 | INITIAL DESIGN |    |     |     |
| 02  | 15.06.15 | REVISED        |    |     |     |
| 03  | 15.08.10 | REVISED        |    |     |     |
| 04  | 15.09.15 | REVISED        |    |     |     |
| 05  | 15.10.20 | REVISED        |    |     |     |
| 06  | 15.11.25 | REVISED        |    |     |     |
| 07  | 15.12.30 | REVISED        |    |     |     |

| NO | NAME           | CODE NO    | SPECIFICATION | QTY | UNIT | REMARKS |
|----|----------------|------------|---------------|-----|------|---------|
| 1  | BACKLIGHT      | BHSR-02/S  | 2 PIN x 145mm | 4   | PCS  |         |
| 2  | LAMP CONNECTOR | FI-X305-HF |               | 4   | PCS  |         |
| 3  | LAMP WIRE      | BHSR-02/S  | 2 PIN x 145mm | 4   | M    |         |



## 8. General Precautions

### 8.1 Handling

- (a) When the module is assembled, it should be attached to the system firmly using every mounting hole. Be careful not to twist and bend the modules.
- (b) Refrain from strong mechanical shock and / or any force to the module. In addition to damage, this may cause improper operation or damage to the module and CCFT back-light.
- (c) Note that polarizers are very fragile and could be damaged easily. Do not press or scratch the surface harder than a HB pencil lead.
- (d) Wipe off water droplets or oil immediately. If you leave the droplets for a long time, stain and discoloration may occur.
- (e) If the surface of the polarizer is dirty, clean it using some absorbent cotton or soft cloth.
- (f) The desirable cleaners are water, IPA(Isopropyl Alcohol) or Hexane. Do not use Ketone type materials(ex. Acetone), Ethyl alcohol, Toluene, Ethyl acid or Methyl chloride. It might damage to the polarizer permanently due to chemical reaction.
- (g) If the liquid crystal material leaks from the panel, it should be kept away from the eyes or mouth. In case of contact with hands, legs or clothes, it must be washed away thoroughly with soap.
- (h) Protect the module from static, it may cause damage to the CMOS Gate Array IC.
- (i) Use finger-stalls with soft gloves in order to keep display clean during the incoming inspection and assembly process.
- (j) Do not disassemble the module.
- (k) Do not pull or fold the lamp wire.
- (l) Do not adjust the variable resistor which is located on the module.
- (m) Protection film for polarizer on the module shall be slowly peeled off just before use so that the electrostatic charge can be minimized.
- (n) Pins of I/F connector shall not be touched directly with bare hands.

## 8.2 Storage

- (a) Do not leave the module in high temperature and high humidity for a long time. It is highly recommended to store the module with temperature from 0 to 35°C and relative humidity of less than 70%.
- (b) Do not store the TFT-LCD module in the direct way of the sun.
- (c) The module shall be stored in a dark place. It is prohibited to apply sunlight or fluorescent light in storing.

## 8.3 Operation

- (a) Do neither connect nor disconnect the module in the "Power On" condition.
- (b) Power supply should always be turned on/off by the item 6.3 "Power on/off sequence"
- (c) Module has high frequency circuits. Sufficient suppression to the electromagnetic interference shall be done by system manufacturers. Grounding and shielding methods may be important to minimize the interference.
- (d) The cable between the back-light connector and its inverter power supply shall be a minimized length and be connected directly . A longer cable between the back-light and the inverter may cause lower luminance of lamp(CCFT) and may require higher startup voltage(Vs).

## 8.4 Others

- (a) An ultra-violet ray filter is necessary for outdoor operation.
- (b) Avoid condensation of water. It may result in improper operation or disconnection of electrode.
- (c) Do not exceed the absolute maximum rating value. ( the supply voltage variation, input voltage variation, variation in part contents and environmental temperature, and so on)  
Otherwise the module may be damaged.
- (d) If the module displays the same pattern continuously for a long period of time, it can be the situation that the image "Sticks" to the screen.
- (e) This module has its circuitry PCB on the rear side so should be handled carefully in order not to stress the PCB.