



SAMSUNG DISPLAY

PRODUCT SPECIFICATION



(√) PRODUCT INFORMATION

() APPROVAL SPECIFICATION

This is Product Information is subject to change after 3 months of issuing date

CUSTOMER	Cisco	MODEL	LTM230HL04
PROGRAM		EXTENSION CODE	

CUSTOMER APPROVAL & FEEDBACK

ARPPROVED BY	10 / Sep. / '12	Daniel Lee	
PREPARED BY	10 / Sep. / '12	Kyle Choi	
<p>Application Engineering Group Samsung Display Co., Ltd.</p>			

Product Configuration Approval Sheet**Description**

Items	Content
Customer	Cisco
Product Name	LTM230HL04
Project Name	-

Customer System Configuration

Items		Content
System Name		-
Purpose		-
IC	Scalar	-
	LED Driver	-
Input Interface		-
OS (AIO)		-
Graphic Card (AIO)		-

Notice : SDC product approval spec guarantee a above customer system.

Contents

Revision History -----	(4)
1. General Description -----	(5)
2. Absolute Maximum Ratings -----	(6)
3. Optical Characteristics -----	(8)
4. Block Diagram -----	(12)
5. Electrical Characteristics -----	(13)
5.1 TFT LCD Module	
5.2 Back Light Unit	
5.3 LVDS Input Characteristics	
5.4 Timing Parameters	
5.5 Input Signals, Basic Display Colors and Gray Scale of Each Color	
5.6 Power ON/OFF Sequence	
5.7 Input Terminal Pin Assignment	
6. Outline Dimension -----	(26)
7. Reliability Test -----	(28)
8. Packing -----	(29)
9. General Precautions -----	(31)
9.1 Handling Precautions	
9.2 Storage Precautions	
9.3 Operation Precaution	
9.4 Design Guide for System	

**SAMSUNG DISPLAY****Revision History**

Version	Date	Page	Description
P0.0	10.Sep., 2012	All	Product information



1. General Description

Overview

LTM230HL04 is a color active matrix liquid crystal display (LCD) that uses amorphous silicon TFT (Thin Film Transistor) as switching components. This model is composed of a TFT LCD panel, a driver circuit and a back light unit. The resolution of a 23.0" is 1920 x 1080 (FHD) and this model can display up to 16.7 million colors.

Features

Application <ul style="list-style-type: none"> - Workstation & Desktop monitors - Display terminals for AV Products - Monitors for Industrial machine
DE (Data Enable) only mode
LVDS (Low Voltage Differential Signaling) interface (2pixel/clock)
RoHS, Halogen Free
White LED Edge slim Backlight (1-side)
TCO 5.1 compliance <ul style="list-style-type: none"> - Except for 2.2 response time; this product does not have over driving function. It is recommended to support in system level

General Information

Items	Specification	Unit
Pixel Pitch	0.2655(H) x 0.2655(W)	mm
Active Display Area	509.76(H) x 286.74(V)	mm
Surface Treatment	AG type, Haze 25% , Hard coating (3H)	-
Display Colors	16.7M (Hi-FRC)	colors
Number of Pixels	1,920 x 1080	pixel
Pixel Arrangement	RGB vertical stripe	-
Display Mode	Normally Black	-
Luminance of White	250(Typ.)	cd/m ²
Power Consumption	Total 18.56W(Typ.) (Panel 4.3W / BLU 14.26W)	W

Mechanical Information

Item		Min.	Typ.	Max.	Unit	Note
Module size	Horizontal (H)	533.5	534.0	534.5	mm	-
	Vertical (V)	311.2	311.7	312.2	mm	
	Depth (D)	-	-	11.0	mm	-
Weight		-	-	2,500	g	LCD module only

Note (1) Mechanical tolerance is $\pm 0.5\text{mm}$ unless there is a special comment.

2. Absolute Maximum Ratings

If the condition exceeds maximum ratings, it can cause malfunction or unrecoverable damage to the device.

Item	Symbol	Min.	Max.	Unit	Note
Power Supply Voltage	V_{DD}	GND-0.5	6.5	V	(1)
Operating Temperature	T_{OPR}	0	50	$^{\circ}\text{C}$	(2)
Storage temperature	T_{STG}	-20	60	$^{\circ}\text{C}$	
Glass surface temperature (Operation)	T_{SUF}	0	65	$^{\circ}\text{C}$	(3)

Note (1) $T_a = 25 \pm 2^{\circ}\text{C}$

- (2) Temperature and relative humidity range are shown in the figure below.
- 90 % RH Max. ($T_a \leq 39\text{ }^\circ\text{C}$)
 - Maximum wet-bulb temperature at $39\text{ }^\circ\text{C}$ or less. ($T_a \leq 39\text{ }^\circ\text{C}$)
 - No condensation.
- (3) The maximum operating temperature of LCD module is defined with surface temperature of active area. Under any condition, the maximum ambient operating temperature should be keeping the surface of active area not any higher than $65\text{ }^\circ\text{C}$

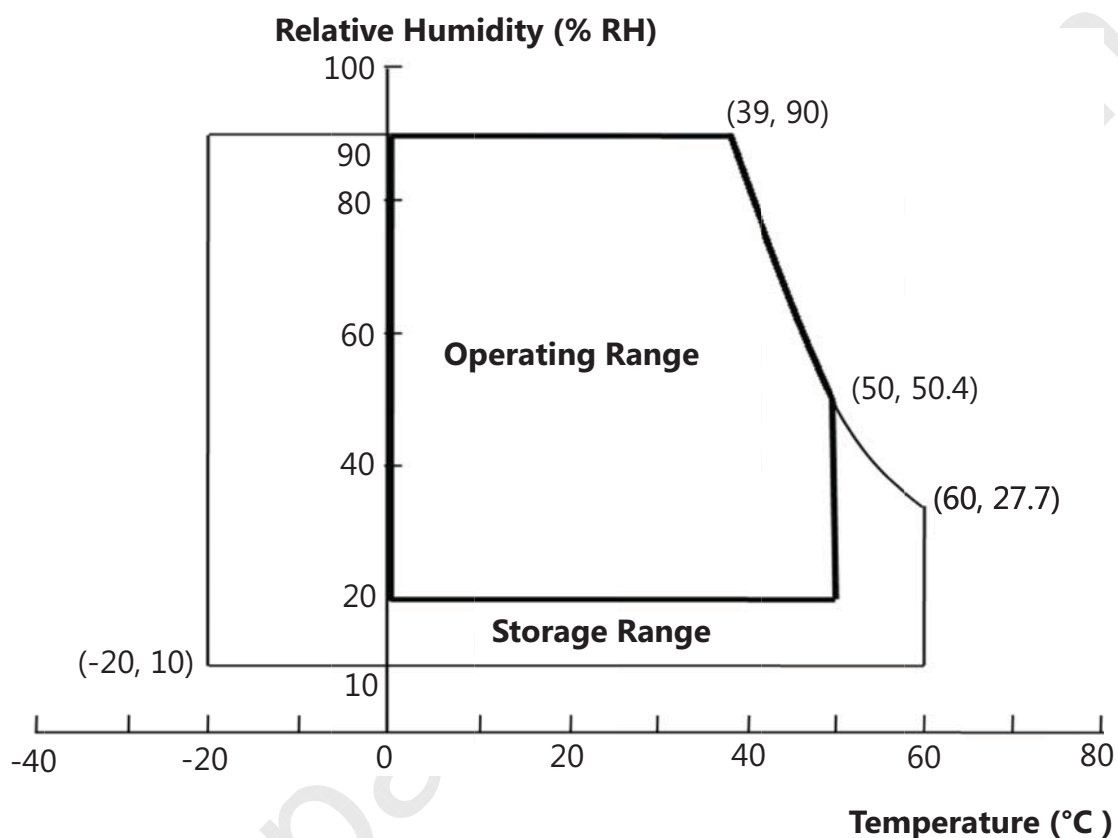

Fig. Temperature and Relative Humidity range

3. Optical Characteristics

The optical characteristics should be measured in a dark room or equivalent.

Measuring equipment : SR-3, RD-80S (TOPCON), EZ-Contrast (Eldim)

($T_a = 25 \pm 2^\circ\text{C}$, $V_{DD}=5\text{V}$, $f_v=60\text{Hz}$, $f_{DCLK}=59.2\text{MHz}$, $I_f=360\text{mA}$)

Item	Symbol	Condition	Min.	Typ.	Max.	Unit	Note
Contrast Ratio (Center of screen)	C/R		600	1000	-		(3) SR-3
Response Time	On/Off	G to G	-	12	-	msec	(5) RD-80S
Luminance of White (Center of screen)	Y_L		200	250	-	cd/m^2	(6) SR-3
Brightness Uniformity (9 Points)	B_{uni}		-	-	25	%	(4) SR-3
Color Chromaticity (CIE 1931)	Red	Rx	Normal $\theta_{L,R}=0$ $\theta_{U,D}=0$	0.645	+0.030		(7),(8) SR-3
		Ry		0.336			
	Green	Gx		0.328			
		Gy		0.615			
	Blue	Bx		0.146			
		By		0.055			
	White	Wx		0.313			
		Wy		0.329			
Color Chromaticity (CIE 1976)	Red	Ru'	-	0.449	-		
		Rv'	-	0.527	-		
	Green	Gu'	-	0.135	-		
		Gv'	-	0.569	-		
	Blue	Bu'	-	0.173	-		
		Bv'	-	0.147	-		
	White	Wu'	-	0.198	-		
		Wv'	-	0.468	-		

SAMSUNG DISPLAY

Item	Symbol	Condition	Min.	Typ.	Max.	Unit	Note	
Color Gamut	-		-	72	-	%		
Color Temperature	-		-	6500	-	K		
Viewing Angle	Hor.	θ_L	CR \geq 10	80	89	-	Degrees	(8) EZ- Contrast
		θ_R		80	89	-		
	Ver.	θ_U		80	89	-		
		θ_D		80	89	-		

Note (1) Test Equipment Setup

The measurement should be executed in a stable, windless and dark room between 30min after lighting the back light at the given temperature for stabilization of the back light. This should be measured in the center of screen.

LED forward current : If = 360mA Environment condition : Ta = 25 \pm 2 $^{\circ}$ C

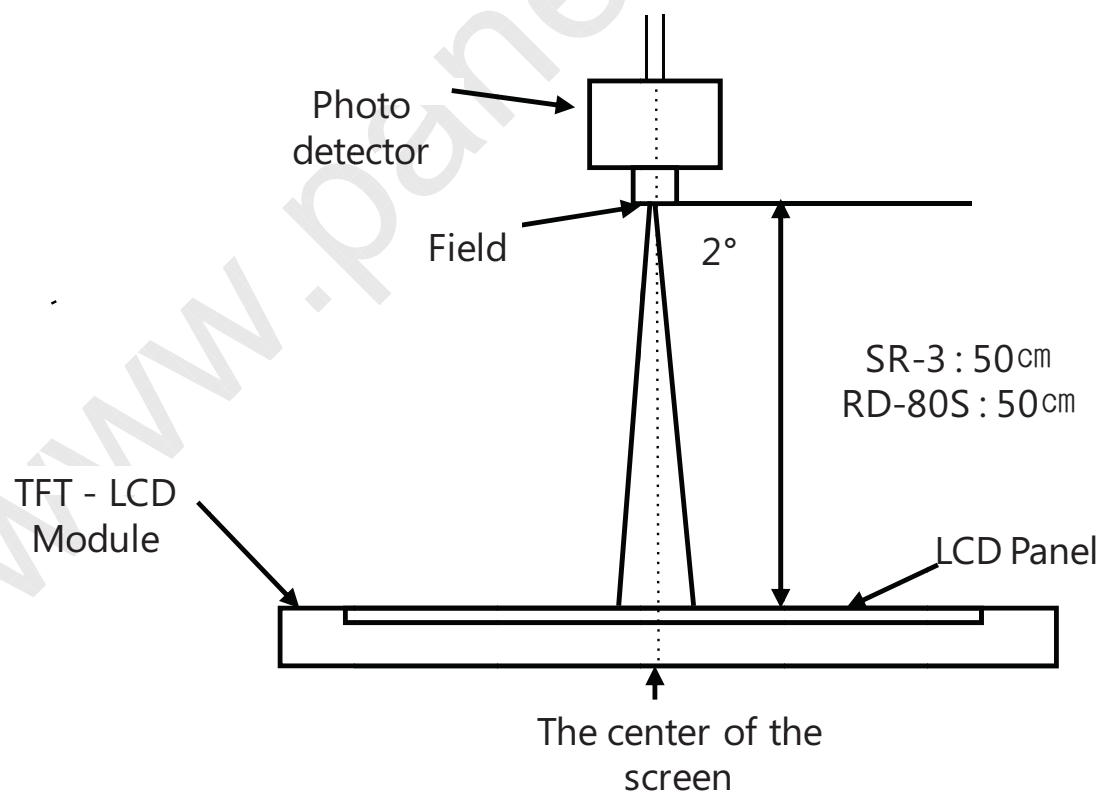

(2) Definition of test point

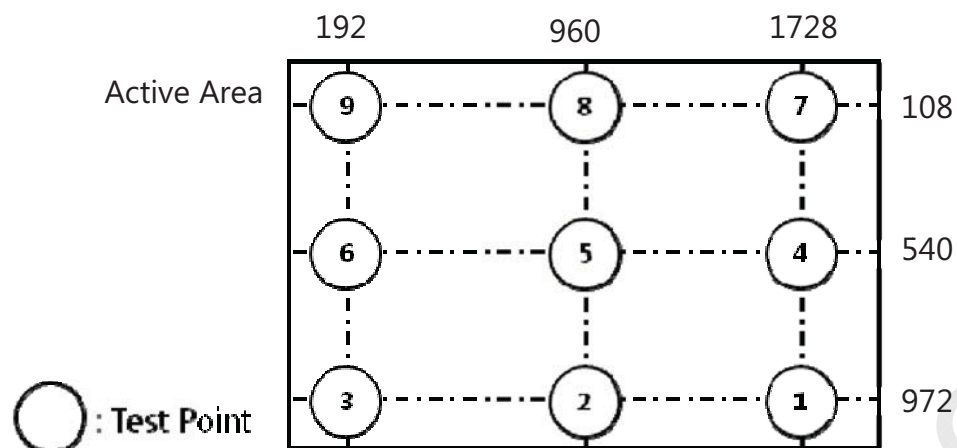

(3) Definition of Contrast Ratio (CR)

: Ratio of gray max (G_{max}) & gray min (G_{min}) at the center point⑤ of the panel

$$CR = \frac{G_{max}}{G_{min}}$$

G_{max} : Luminance with all pixels white

G_{min} : Luminance with all pixels black

(4) Definition of 9 points brightness uniformity

$$B_{uni} = 100 \times \frac{B_{max} - B_{min}}{B_{max}}$$

B_{max} : Maximum brightness

B_{min} : Minimum brightness

(5) Definition of Response time

GtoG : The time for transitions between specific gray levels

- 31 → 63, 63 → 95, 95 → 127, 127 → 159, 159 → 191, 191 → 223 grays and vice versa

- G to G typ. : Average time at rising and falling for gray transition except the transition

Optical Instruments

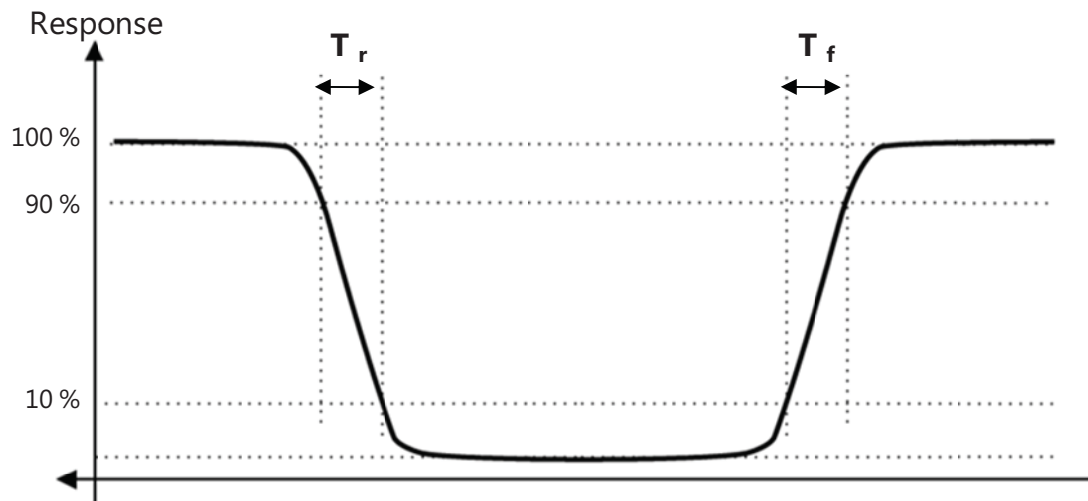

(6) Definition of Luminance of White : Luminance of white at center point (5)

(7) Definition of Color Chromaticity (CIE 1931, CIE1976)

Color coordinate of Red, Green, Blue & White at center point (5)

(8) Definition of Viewing Angle

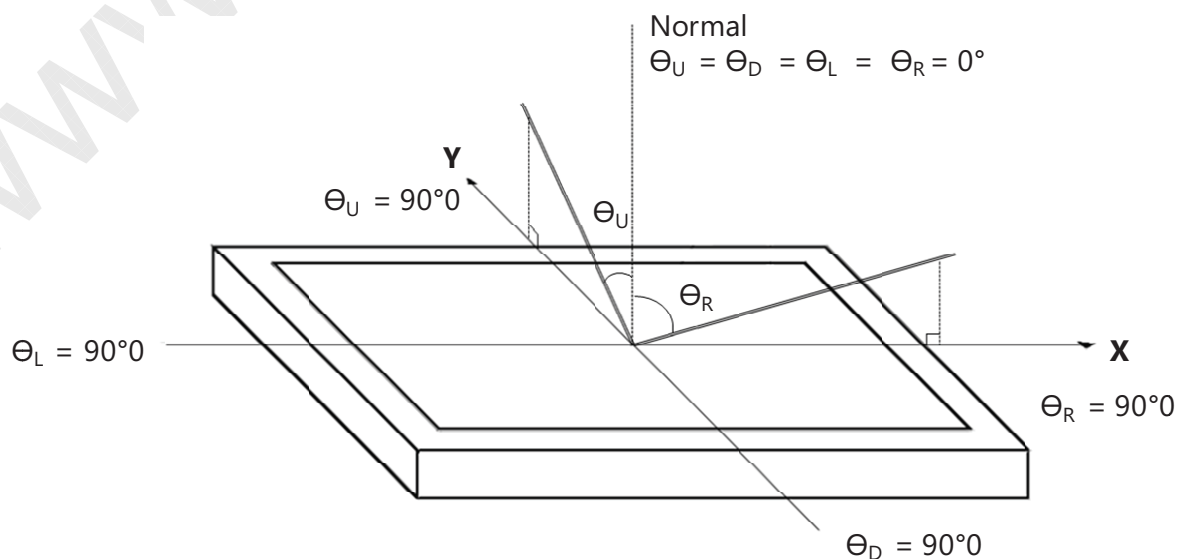
: Viewing angle range ($CR \geq 10$)

4. Block Diagram

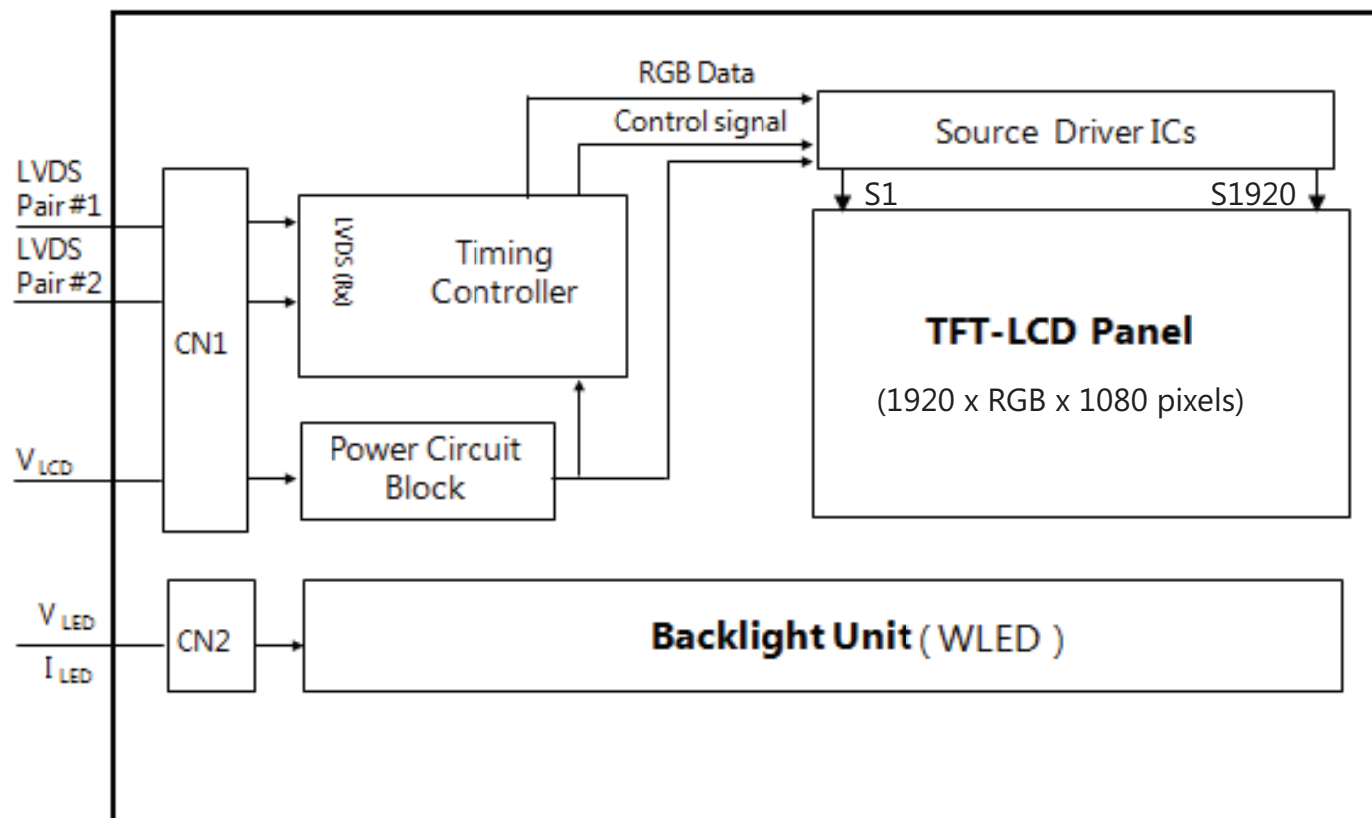

Fig. Function Block Diagram

Note (1) The connector for display data & timing signal should be connected

5. Electrical Characteristics

5.1 TFT LCD Module

The connector for display data & timing signal should be connected.

$T_a = 25 \pm 2^\circ\text{C}$

Item	Symbol	Min.	Typ.	Max.	Unit	Note
Voltage of Power Supply	V_{DD}	4.5	5.0	5.5	V	(1)
Power Dip Condition	V_{CC}	4.0	-	V_{DD}	V	(2)
	T_d	0	-	20	msec	
Current of Power Supply	(a) White	-	1,070	1,170	mA	(3),(4)
	(b) Black	-	650	-	mA	
	(c) Dot	-	860	-	mA	
Power Consumption	P_{LCD}	-	4.3	-	Watt	(4),(5)
Rush Current	I_{RUSH}	-	-	3.0	A	(6)

Note (1) The ripple voltage should be controlled under 10% of V_{DD}

(2) Definition of V_{DD} Power Dip

- The above conditions are for the glitch of the input voltage.
- For stable operation of an LCD Module power, please follow them.

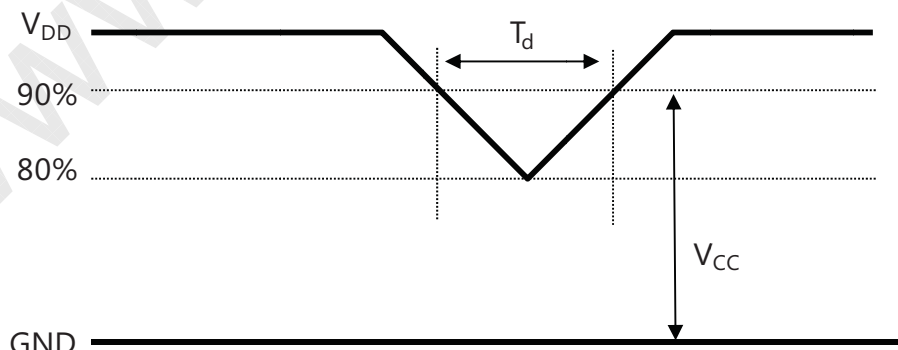

$$4.5\text{V} \leq V_{DD} \leq 5.5\text{V}$$

$$\text{If } V_{DD}(\text{Typ.}) \times 80\% \leq V_{CC} \leq V_{DD}(\text{Typ.}) \times 90\%,$$

$$\text{then } 0 < T_d \leq 20\text{msec}$$

(3) $f_V=60\text{Hz}$, $f_{\text{DCLK}} = 67.3\text{Hz}$, $V_{\text{DD}} = 5.0\text{V}$, DC Current.

(4) Power dissipation check pattern (LCD Module only)

a) White Pattern



b) Black Pattern



c) Dot Pattern

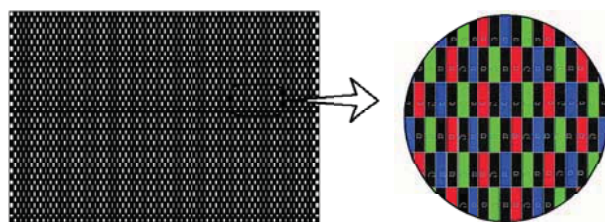

(5) The power consumption is specified whereas Dot pattern is displayed at $f_V=60\text{Hz}$, $f_{\text{DCLK}} = 67.3\text{MHz}$, $V_{\text{DD}} = 5.0\text{V}$

(6) Measurement Condition

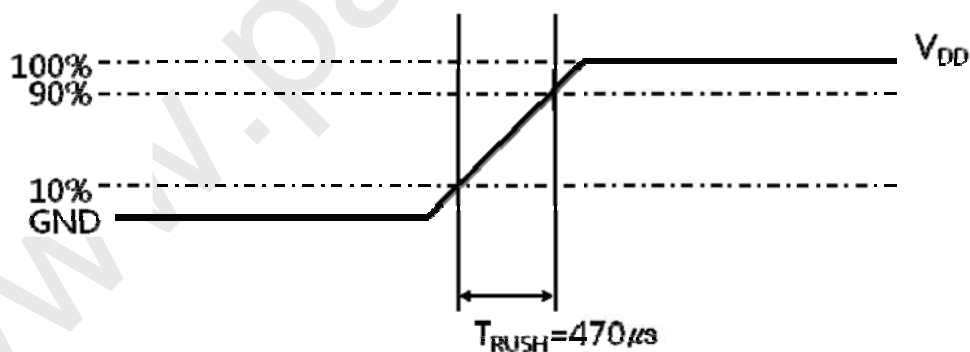

Rush Current I_{RUSH} can be measured when T_{RUSH} is $470\mu\text{s}$

5.2 Backlight Unit

The characteristics of LED bar

Ta=25 ± 2°C.

Item	Symbol	Min.	Typ.	Max.	Unit	Note
LED Forward Current	I_F	-	360	390	mA	(1),(2)
LED Array Voltage	V_P	-	39.6	42.0	V	(1)
Power Consumption	P_{BLU}	-	14.26	-	Watt	(3)
Operating Life Time	Hr	30,000	-	-	Hour	(4)

Note (1) The above specification is not for the converter output, but for the LED bar.

- The LED bar consists of 36 LED packages ; 3 parallel X 12 serial
- LED current is defined at 100% duty ratio of LED driver

(2) The LED Forward current for single LED channel is Typ.120mA

- The output current of converter in the system should be transmitted to the LED bar constantly.
- It is recommended to control the returned signal respectively for even distribution of current to each channel of LED bar

(3) The power consumption is specified at typical current 360mA with 100% duty ratio

- It does not include power loss of external LED driver circuit block
- Typical power consumption $P_{BLU} = I_F (\text{Typ.}) \times V_P (\text{Typ.})$

(4) Life time(Hr) is defined as the time when brightness of a LED package itself becomes 50% or less than its original value at the condition of Ta=25 ± 2°C and $I_F = 360\text{mA}$.

5.3 LVDS Characteristics

5.3.1. LVDS Input Characteristics

Ta=25 ± 2°C

Item	Symbol	Min.	Typ.	Max.	Unit	Note
Differential Input Voltage for LVDS receiver threshold	High	-	-	+50	mV	(1)
	Low	-50	-	-	mV	
LVDS skew	t_{SKEW}	-300	-	300	ps	(2)
Differential input voltage	$ V_{id} $	100	-	600	mV	(3)
Input voltage range(single ended)	V_{in}	0.7	-	1.7	V	(3)
Common mode voltage	V_{cm}	1.0	1.2	1.4	V	(3)

Note (1) Differential receiver voltage definitions and propagation delay and transition time test circuit

- All input pulses have frequency = 10MHz, t_R or t_F = 1ns
- C_L includes all probe and fixture capacitance

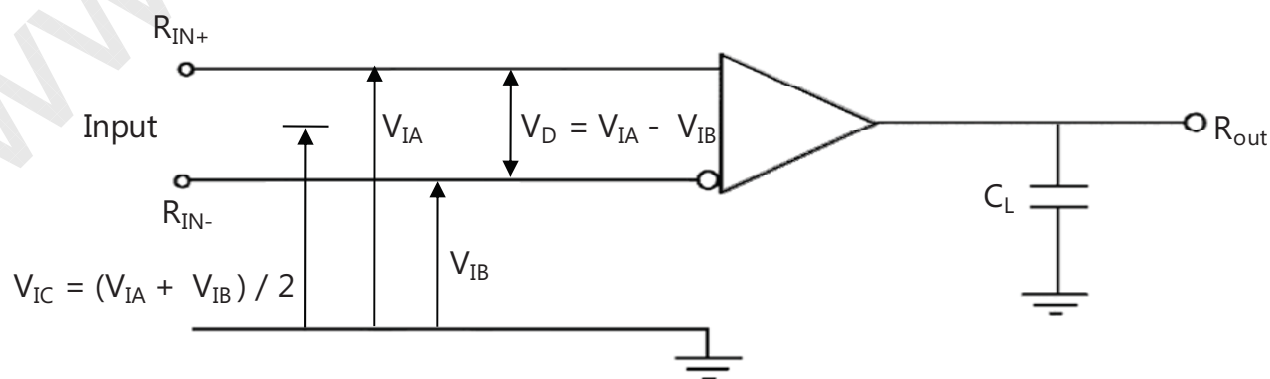

(2) LVDS Receiver DC parameters are measured under static and steady conditions which may not be reflective of its performance in the end application.

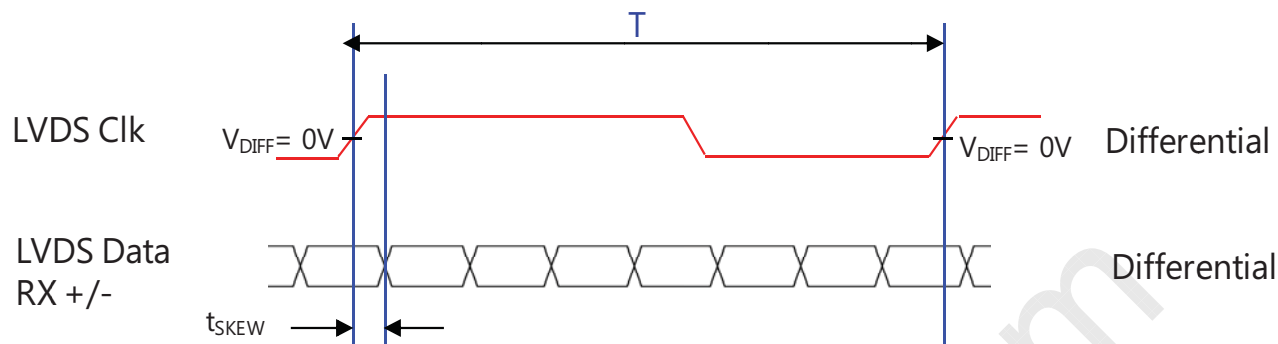

where t_{SKEW} : skew between LVDS clock & LVDS data,

T : 1 period time of LVDS clock

cf. (-/+) of 300psec means LVDS data goes before or after LVDS clock

(3) Definition of V_{ID} and V_{CM} using single-end signals

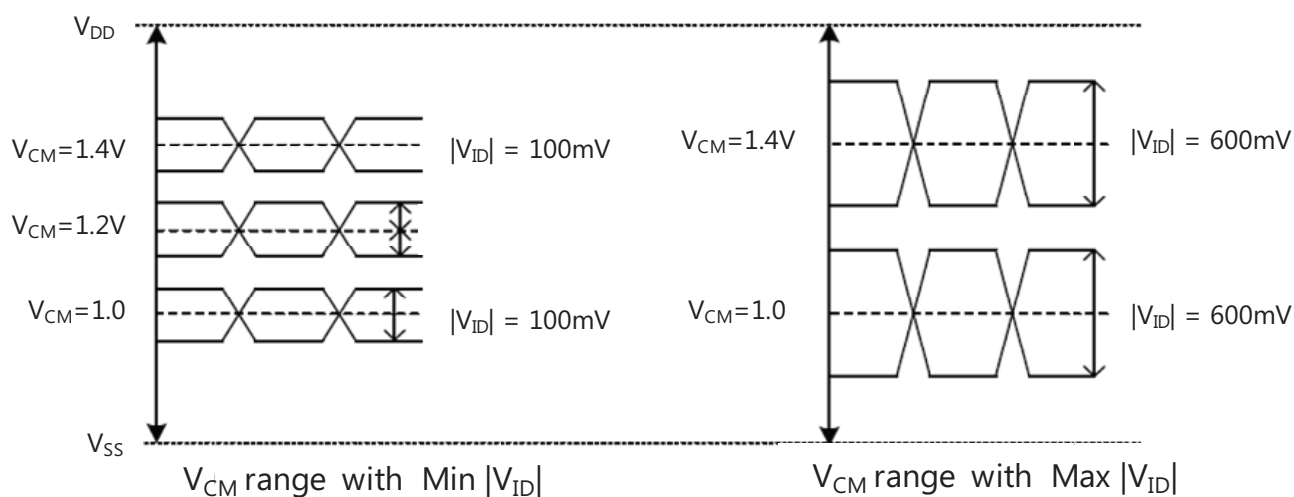

5.3.2. LVDS Data Format

Timing Diagrams of LVDS For Transmitting
 - LVDS Receiver : Integrated T-CON

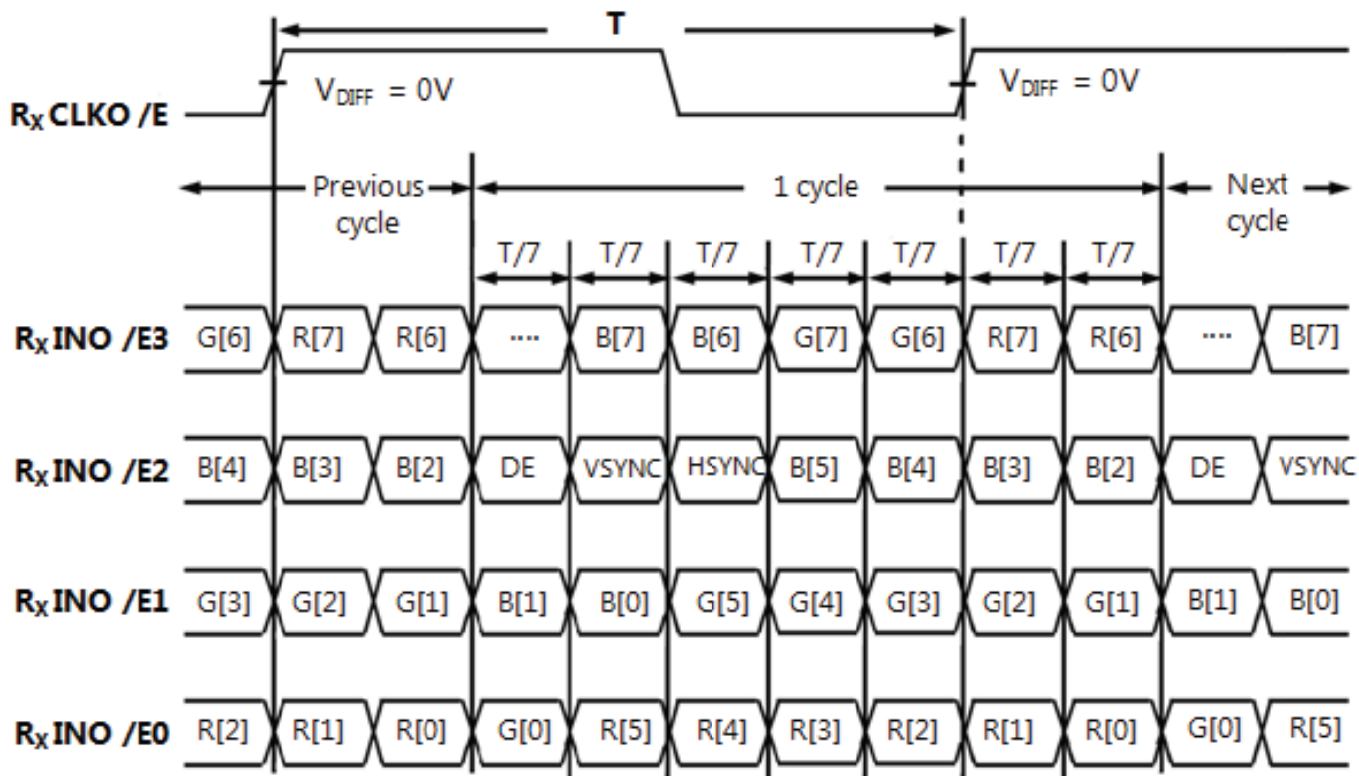

5.4 Interface Timing Specification

5.4.1. Timing Parameters

SIGNAL	ITEM	SYMBOL	Min.	Typ.	Max.	Unit	Note
Clock	Frequency	$1/T_C$	56.4	67.3	83.0	MHz	-
Hsync		F_H	54.2	66.0	83.8	kHz	-
Vsync		F_V	49	60	75	Hz	-
Vertical Display Term	Active Display Period	T_{VD}	1080	1080	1080	Lines	-
	Vertical Total	T_V	1105	1111	1118	Lines	-
Horizontal Display Term	Active Display Period	T_{HD}	960	960	960	Clocks	2pixel/clock
	Horizontal Total	T_H	990	1010	1040	clocks	2pixel/clock

Note (1) DE only mode

- While operation, DE signal should be have the same cycle.

(2) Best operation clock frequency is 67.3MHz(60Hz)

(3) Clock frequency = Frame frequency x T_V (Typ.) x T_H (Typ.)

(4) Max, Min variation range is at main clock typical value (67.3MHz)

(5) Main frequency Max is 83.0MHz without spread spectrum

5.4.2. Timing diagrams of interface signal (DE only mode)

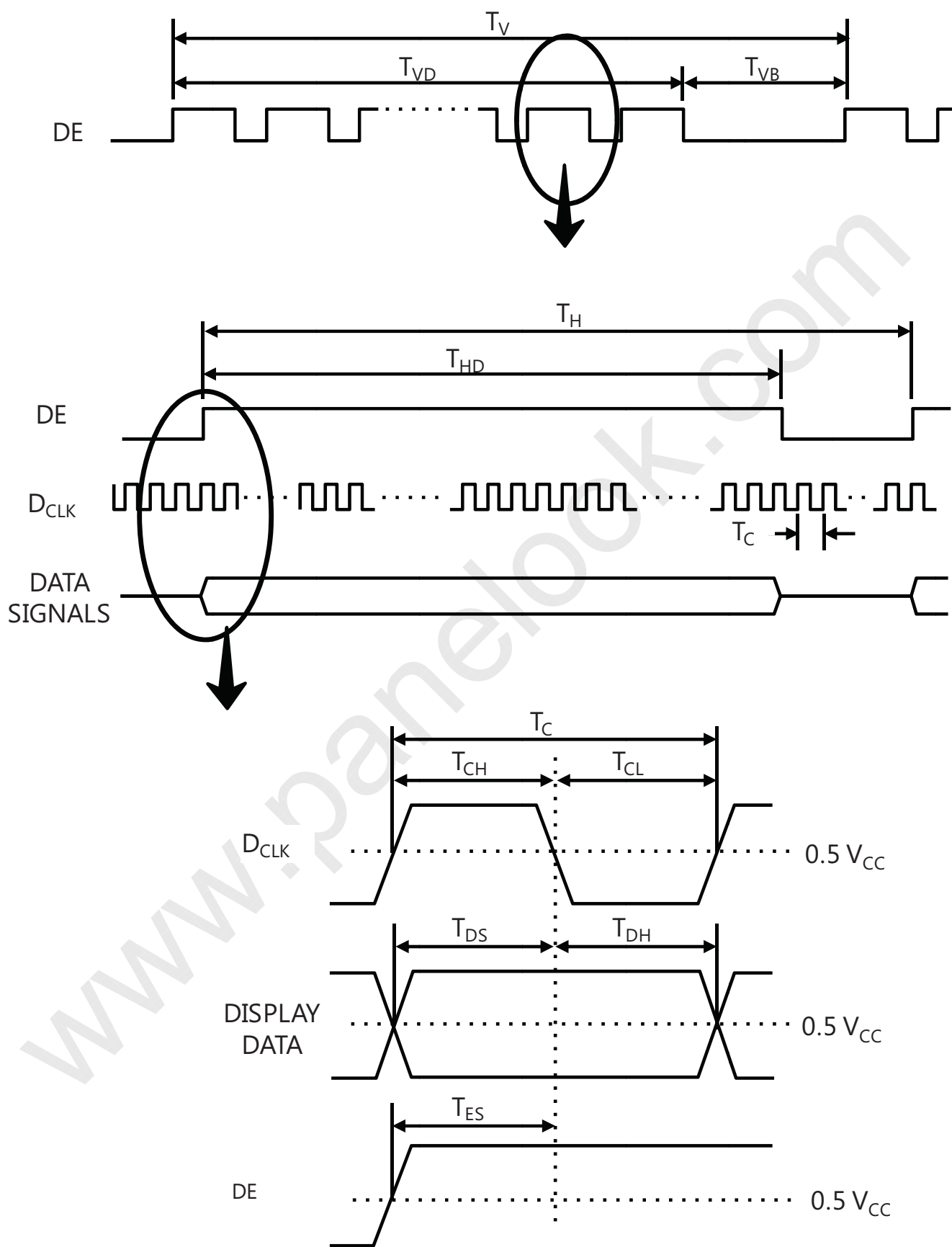

5.5 Input Signals, Basic Display Colors and Gray Scale of Each Color

COLOR	DISPLAY (8bit)	DATA SIGNAL																					GRAY SCALE LEVEL			
		RED							GREEN							BLUE										
		R0	R1	R2	R3	R4	R5	R6	R7	G0	G1	G2	G3	G4	G5	G6	G7	B0	B1	B2	B3	B4		B5	B6	B7
BASIC COLOR	BLACK	0	0	0	0	0	0	0	0	0	0	0	0	0	0	0	0	0	0	0	0	0	0	0	-	
	BLUE	0	0	0	0	0	0	0	0	0	0	0	0	0	0	0	0	1	1	1	1	1	1	1	1	-
	GREEN	0	0	0	0	0	0	0	0	1	1	1	1	1	1	1	1	0	0	0	0	0	0	0	0	-
	CYAN	0	0	0	0	0	0	0	0	1	1	1	1	1	1	1	1	1	1	1	1	1	1	1	1	-
	RED	1	1	1	1	1	1	1	1	0	0	0	0	0	0	0	0	0	0	0	0	0	0	0	0	-
	MAGENTA	1	1	1	1	1	1	1	1	0	0	0	0	0	0	0	0	1	1	1	1	1	1	1	1	-
	YELLOW	1	1	1	1	1	1	1	1	1	1	1	1	1	1	1	1	0	0	0	0	0	0	0	0	-
	WHITE	1	1	1	1	1	1	1	1	1	1	1	1	1	1	1	1	1	1	1	1	1	1	1	1	-
GRAY SCALE OF RED	BLACK	0	0	0	0	0	0	0	0	0	0	0	0	0	0	0	0	0	0	0	0	0	0	0	R0	
	DARK ↑	1	0	0	0	0	0	0	0	0	0	0	0	0	0	0	0	0	0	0	0	0	0	0	R1	
		0	1	0	0	0	0	0	0	0	0	0	0	0	0	0	0	0	0	0	0	0	0	0	R2	
		:	:	:	:	:	:	:	:	:	:	:	:	:	:	:	:	:	:	:	:	:	:	:	:	.
	↓ LIGHT	1	0	1	1	1	1	1	1	0	0	0	0	0	0	0	0	0	0	0	0	0	0	0	R253	
		0	1	1	1	1	1	1	1	0	0	0	0	0	0	0	0	0	0	0	0	0	0	0	R254	
		1	1	1	1	1	1	1	1	0	0	0	0	0	0	0	0	0	0	0	0	0	0	0	R255	
	RED	1	1	1	1	1	1	1	1	0	0	0	0	0	0	0	0	0	0	0	0	0	0	0	R255	
GRAY SCALE OF GREEN	BLACK	0	0	0	0	0	0	0	0	0	0	0	0	0	0	0	0	0	0	0	0	0	0	0	G0	
	DARK ↑	0	0	0	0	0	0	0	0	1	0	0	0	0	0	0	0	0	0	0	0	0	0	0	G1	
		0	0	0	0	0	0	0	0	0	1	0	0	0	0	0	0	0	0	0	0	0	0	0	G2	
		:	:	:	:	:	:	:	:	:	:	:	:	:	:	:	:	:	:	:	:	:	:	:	.	
	↓ LIGHT	0	0	0	0	0	0	0	0	1	0	1	1	1	1	1	1	0	0	0	0	0	0	0	G253	
		0	0	0	0	0	0	0	0	0	1	1	1	1	1	1	1	0	0	0	0	0	0	0	G254	
		0	0	0	0	0	0	0	0	1	1	1	1	1	1	1	1	0	0	0	0	0	0	0	G255	
	GREEN	0	0	0	0	0	0	0	0	1	1	1	1	1	1	1	1	0	0	0	0	0	0	0	G255	
GRAY SCALE OF BLUE	BLACK	0	0	0	0	0	0	0	0	0	0	0	0	0	0	0	0	0	0	0	0	0	0	0	B0	
	DARK ↑	0	0	0	0	0	0	0	0	0	0	0	0	0	0	0	0	1	0	0	0	0	0	0	B1	
		0	0	0	0	0	0	0	0	0	0	0	0	0	0	0	0	0	1	0	0	0	0	0	B2	
		:	:	:	:	:	:	:	:	:	:	:	:	:	:	:	:	:	:	:	:	:	:	:	.	
	↓ LIGHT	0	0	0	0	0	0	0	0	0	0	0	0	0	0	0	0	1	0	1	1	1	1	1	B253	
		0	0	0	0	0	0	0	0	0	0	0	0	0	0	0	0	0	1	1	1	1	1	1	B254	
		0	0	0	0	0	0	0	0	0	0	0	0	0	0	0	0	1	1	1	1	1	1	1	B255	
	BLUE	0	0	0	0	0	0	0	0	0	0	0	0	0	0	0	0	1	1	1	1	1	1	1	B255	

Note (1) Definition of Gray

- Rn : Red Gray, Gn : Green Gray, Bn : Blue Gray (n = Gray level)

Input Signal : 0 = Low level voltage, 1 = High level voltage

5.6 Power ON/OFF Sequence

To prevent a latch-up or DC operation of the LCD Module, the power on/off sequence should be as the diagram below.

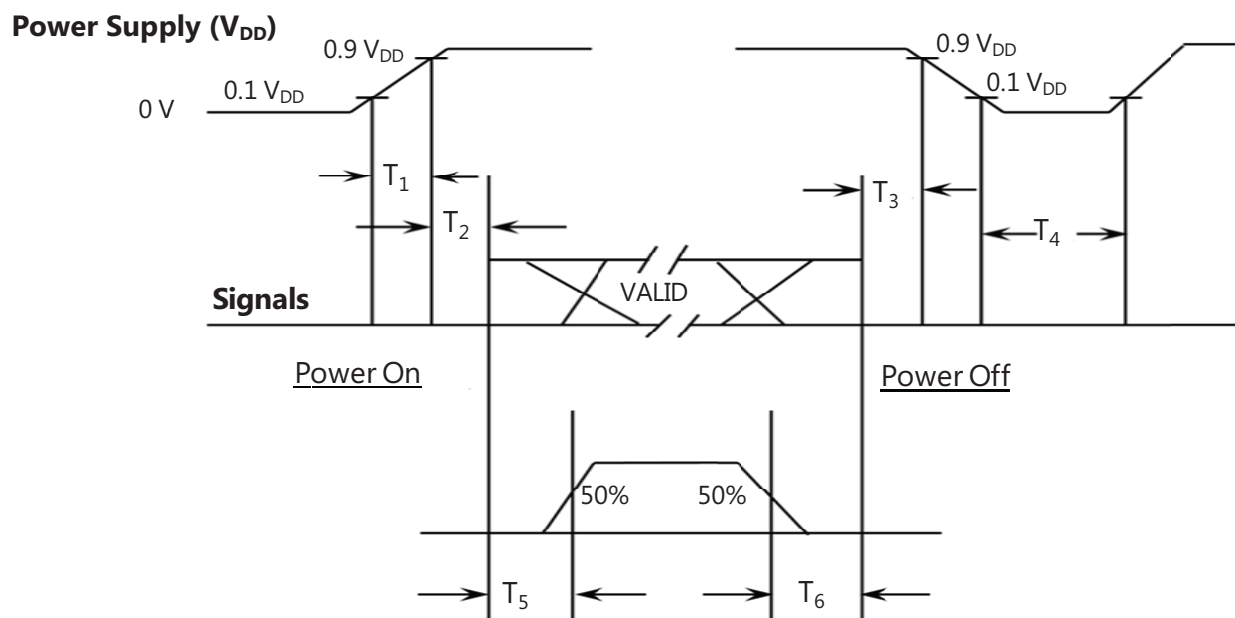

SYMBOL	Min.	Typ.	Max.	Unit	Description
T_1	0.5	-	10	ms	V_{DD} rising time from 10% to 90%
T_2	0.01	-	50	ms	The time from V_{DD} to valid data at power ON
T_3	0.01	-	50	ms	The time from valid data off to V_{DD} off at power Off
T_4	1	-	-	s	V_{DD} off time for Windows restart
T_5	500	-	-	ms	The time from valid data to B/L enable at power ON
T_6	100	-	-	ms	The time from valid data off to B/L disable at power Off

Note (1) The supply voltage of the external system for the Module input should be the same as the definition of VDD.

(2) Apply the BLU power within the LCD operation range. When the back light turns on before the LCD operation or the LCD turns off before the back light turns off, the display may momentarily show abnormal screen.

(3) In case of $V_{DD} = \text{off level}$, please keep the level of input signals low or keep a high impedance.

(4) T_4 should be measured after the Module has been fully discharged between power off and on period.

(5) Interface signal should not be kept at high impedance when the power is on.

5.7 Input Terminal Pin Assignment

5.7.1. Input signal & Power Pin Assignment

Connector : UJU IS100-L30B-C23 or equivalent

Pin No.	Symbol	Function
1	RXO0N	Negative LVDS differential data output
2	RXO0P	Positive LVDS differential data output
3	RXO1N	Negative LVDS differential data output
4	RXO1P	Positive LVDS differential data output
5	RXO2N	Negative LVDS differential data output
6	RXO2P	Positive LVDS differential data output
7	GND	High speed ground
8	RXOC-	Negative Sampling Clock (ODD data)
9	RXOC+	Positive Sampling Clock (ODD data)
10	RXO3N	Negative LVDS differential data output
11	RXO3P	Positive LVDS differential data output
12	RXE0N	Negative LVDS differential data output
13	RXE0P	Positive LVDS differential data output
14	GND	High speed ground
15	RXE1N	Negative LVDS differential data output
16	RXE1P	Positive LVDS differential data output
17	GND	High speed ground
18	RXE2N	Negative LVDS differential data output
19	RXE2P	Positive LVDS differential data output
20	RXEC-	Negative Sampling Clock (EVEN data)
21	RXEC+	Positive Sampling Clock (EVEN data)
22	RXE3N	Negative LVDS differential data output
23	RXE3P	Positive LVDS differential data output
24	GND	LCD logic and driver ground
25	NC	* Reserved for LCD manufacturer's use (CE_DVR)
26	NC	* Reserved for LCD manufacturer's use (CTL_DVR)
27	NC	No Connection
28	VDD	Power Supply : +5V
29	VDD	
30	VDD	

Note (1) If the system already uses the 25, 26pins, it should keep under GND level
The voltage applied to those pins should not exceed -200mV.

(2) Pin number starts from Left side

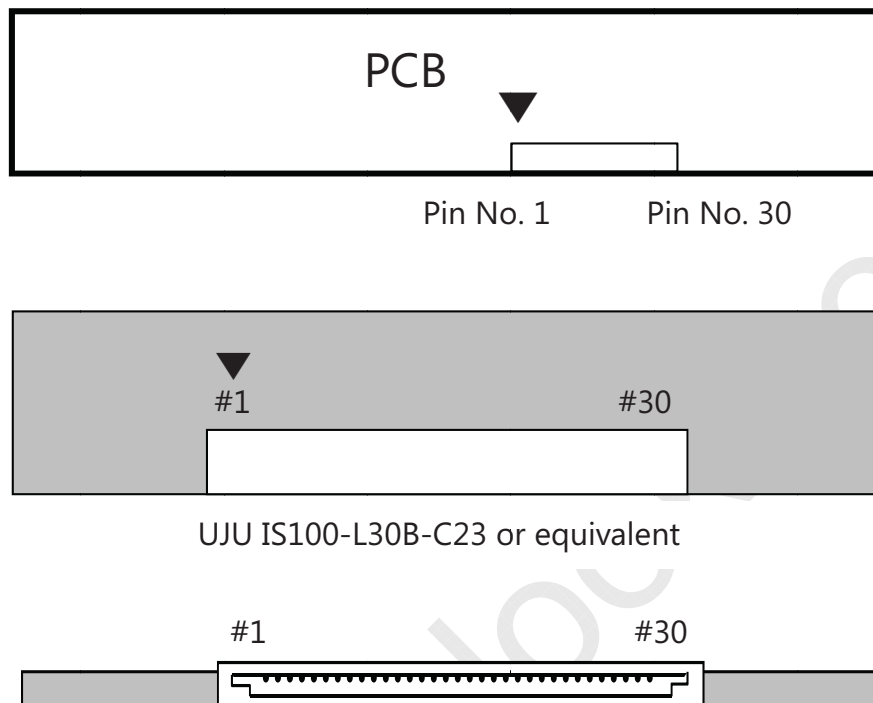

Fig. Connector diagram

- (3) All GND pins should be connected together and also be connected to the LCD's metal chassis.
- (4) All power input pins should be connected together.
- (5) All NC pins should be separated from other signal or power

5.7.2. LED Connector Pin assignment

Connector : Molex 104086-0410 pr equivalent

- The mating type connector : Molex 104085-0410 or equivalent

Pin No.	Symbol	Function
1	Vin	LED power input
2	RTN 1	Channel 1 LED return
3	RTN 2	Channel 2 LED return
4	RTN 3	Channel 3 LED return

Note (1) Pin number starts from Left side

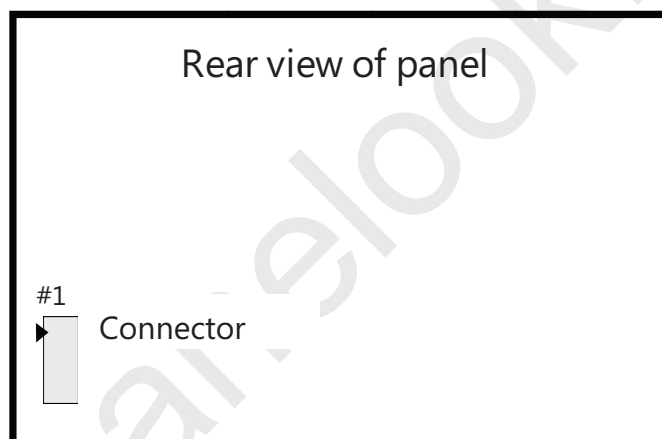

Fig. Connector diagram



6. Outline Dimension

[Refer to the next page]

www.panelook.com



7. Reliability test

Test Item	Condition	Time/Cycle	
HTOL	50°C , Bias	500 hrs	
LTOL	0°C , Bias	500 hrs	
THB	40°C / 95% , Bias	500 hrs	
HTS	70°C , No Bias	500 hrs	
LTS	-20°C , No Bias	500 hrs	
Thermal Cycle	-20°C/30min ~ +60°C/30min , No bias	100 cycle	
Shock (Non-operating)	50G , 11msec Sine wave , ± x/y/z axis	1 time/axis	
Vibration (Non-operating)	1.5G , 5~200 Hz x/y/z axis , sweep rate : 10 min	30min/axis	
ESD	Non-Operating	CDM : 150pF, 330Ω, 9point, 3 times/point	± 10kV
	Operating	Contact : 150pF, 330Ω, 100point, once/point	± 8kV
		Air(non-contact) : 150pF, 330Ω, 100point, once/point	± 15kV
Altitude	Thermal :-10~50°C, 15000ft(Operating), 40000ft(Non-operating) Normal :45°C, 15000ft	8Hr 10Hr	

[Result Evaluation Criteria]

Under the display quality test conditions with normal operation state, these should be no change which may affect practical display functions.

- HTOL / LTOL : High/Low Temperature Operating Life
- THB : Temperature Humidity Bias
- HTS/LTS : High/Low Temperature Storage

8. Packing

8.1 Carton

Item	Packing form	Specification
Weight	-	- Total Weight (Including Pallet) : Approx. 510Kg
Packing case	12 panels in a case	- Packing Case Size : W255 x L625 x H372 - Material : Paper (SW,DW)
Pallet box	16 cases in a box 192 panels in a box	- Packing Pallet Box Size : W1084 x L1268 x H736 - Material : Paper (SW)
Pallet	-	- Pallet Size : W1270 x L1150 x H122 - Material : Wood

Packing Pallet box

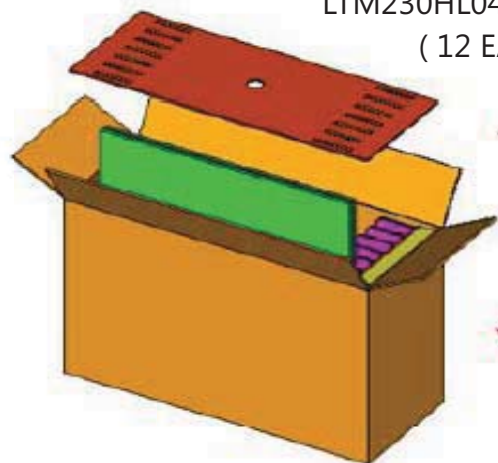
LTM230HL04 Module
(12 EA)

PACKING-Case

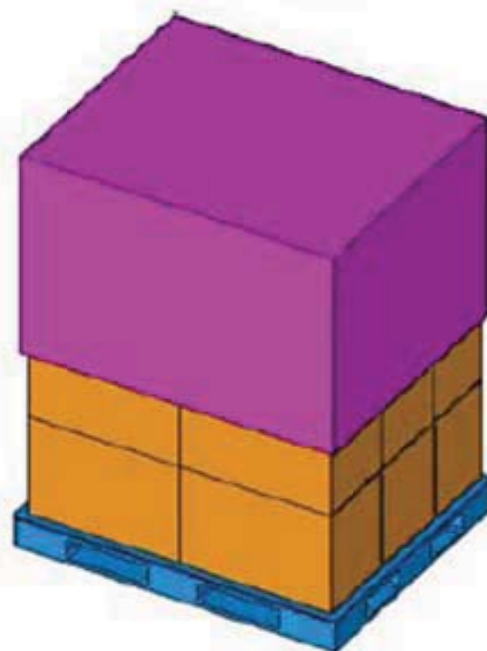

Wood Pallet

SAMSUNG DISPLAY

8.2 Marking

A nameplate bearing followed by is affixed to a shipped product at the specified location on each product.

- (1) Parts number : LTM230HL04
- (2) Revision: Three letters
- (3) Lot number : X X X X XXX XX X

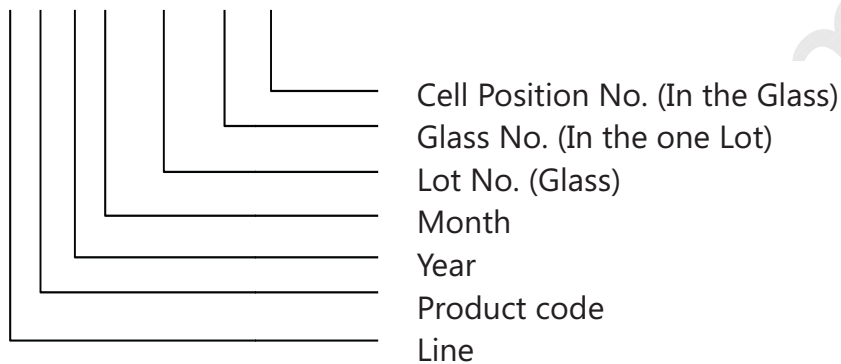

(4) Nameplate Indication

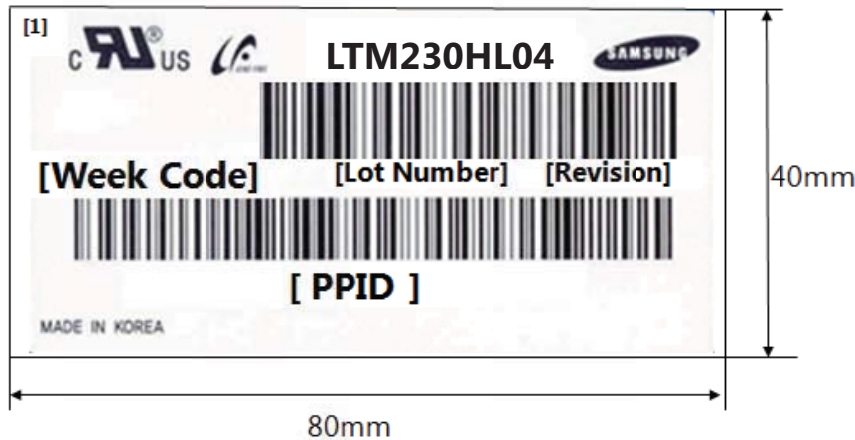

Week code : 11 09
 └─ week
 └─ year

[1] : Manufacturing site

(5) Packing box attach

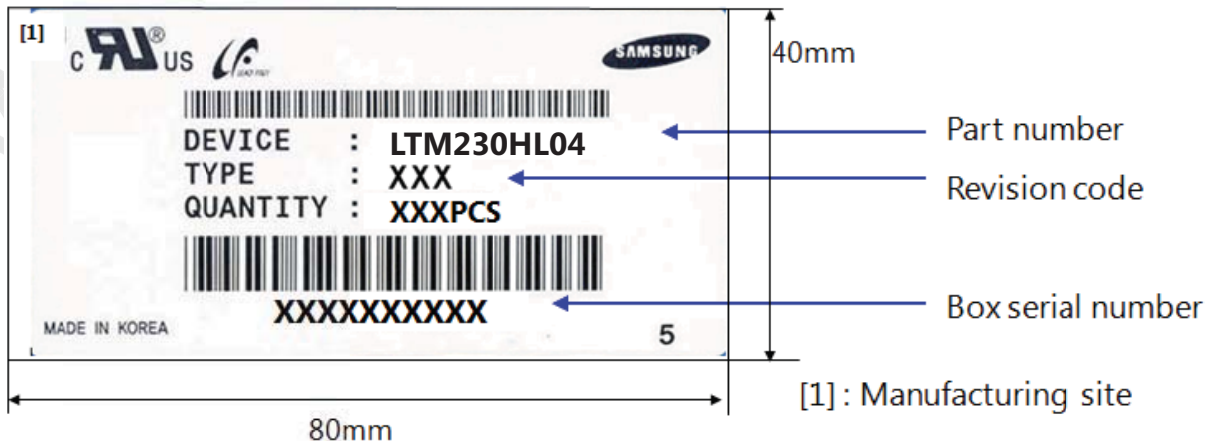

[1] : Manufacturing site

9. General Precautions

9.1 Handling Precautions

- A. When assembling LCD module into its system, using all the mounting holes is strongly suggested.
- B. Keep LCD module from any external shock or force which can cause physical damage to LCD module. It may cause improper operation or damage to LCD module.
- C. Polarizer films are very fragile. It could be damaged easily. Do not press or scratch the surface harder than a HB pencil lead.
- D. Wipe off water droplets or oil immediately. Water drops or oils can cause permanent stain or discoloration.
- E. To clean LCD module, please use IPA (Isopropyl Alcohol) or Hexane.
- F. Do not use ketone type material (ex. Acetone), ethyl alcohol, toluene, ethyl acid or methyl chloride. Using these could cause permanent polarizer damage to the LCD module.
- G. If the liquid crystal leaks from LCD module, keep it away from human eyes or mouth. In case of contact with human body or clothes, it should be washed with soap thoroughly.
- H. Protect LCD module from static discharge.
 - I. To keep the LCD module clean, make sure to wear fabric gloves and finger coats when you are inspecting and/or assembling the unit.
- J. Do not disassemble LCD module.
- K. Protection film on LCD module display area should be slowly peeled off just before assembly to prevent static discharge.
- L. Pins of the Interface connector should not be touched directly with bare hands.

9.2 Storage Precautions

It is highly recommended to comply with the criteria in the table below

Item	Unit	Min.	Max.
Storage Temperature	(°C)	5	40
Storage Humidity	(%rH)	35	75
Storage life	12 months		
Storage Condition	<ul style="list-style-type: none"> - The storage room should provide good ventilation and temperature Control . - Products should not be placed on the floor, but on the Pallet away from a wall . - Prevent products from direct sunlight, moisture nor water; Be cautious of a build up of condensation. - Avoid other hazardous environment while storing goods. - If products delivered or kept in conditions of over the storage period of 3 months, the recommended temperature or humidity range, it is recommended to leave them at a temperature of 20°C and a humidity of 50% for 24 hours. 		

9.3 Operating Precautions

- A. If the module is used to other applications besides the recommendation on General Description, please contact SAMSUNG for application engineering device in advance
- B. Do not connect or disconnect the LCD module when it is set to the "Power On" condition.
- C. Input power should always follow '5.6 Power on/off sequence'
- D. Polarizer films are very fragile. It could be damaged easily. Do not press or scratch the Polarizer films
- E. LCD module contains electrical circuits that operate in high frequencies. To minimize electromagnetic interference, be sure to sufficiently ground and shield the LCD module and system.
- F. If LCD module containing system is out of SAMSUNG 's operating condition, SAMSUNG can not guarantee LCD module operating properly.
- G. If the product will be used in extreme conditions such as high temperature, humidity, display patterns, operation time, etc., it is strongly recommended to contact SAMSUNG for application engineering device. Otherwise, the reliability and function of the module may not be guaranteed. Extreme conditions are commonly found at airports, transit stations, banks, stocks, markets, and controlling systems.
- H. Ultra-violet ray filter is necessary for outdoor operation.
- I. If the module keeps displaying the same pattern for a long period of time, the image maybe burned in to the screen. To avoid image retention, it is recommended to use a screen saver.
- J. This module has its PCB's circuitry on the rear side and should be handled carefully in order to avoid stress.
- K. Please contact SAMSUNG beforehand, if you plan to display the same pattern for a long period of time.
- L. Any foreign materials brought into an LCD module by external forced-airflow are not guaranteed by SAMSUNG .

9.4 Design Guide for System

- A. The LED driver should be designed in compliance with the specifications of LED bar strictly to make the LED in LCD module perform as expected.
- B. Design the rib of front cover of system not to be placed on the location where the driver ICs are located on the LCD module. It is recommended to place the rib of front cover of system at the point between the bottom chassis and the hook of mold frame to prevent the LCD module from being defected, which is resulted from the interference between the system and the LCD module.
(See '6. Outline Dimension ' for the exact location of driver ICs)

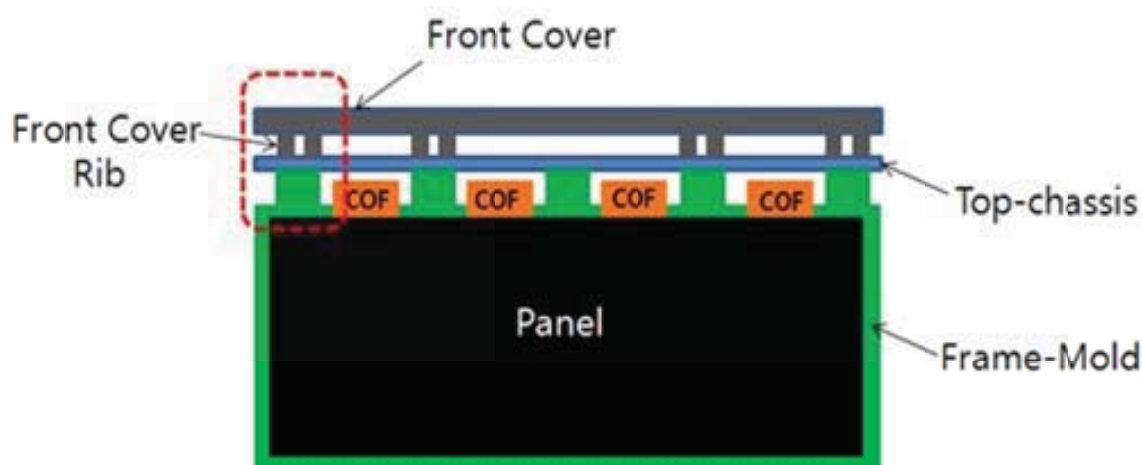

- C. Start screwing mounting holes from ones on the part, which the light source is located. It is recommended to prevent the mounting screw from being slid out.

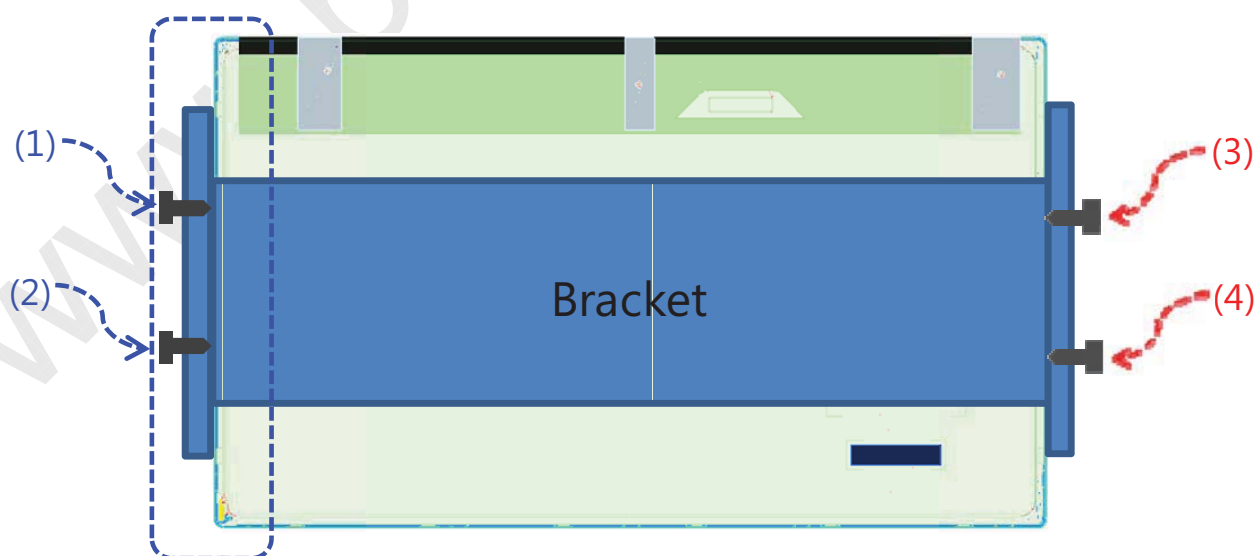

SAMSUNG DISPLAY

- D. Design the system bracket to be placed with being laid across on the LCD module. The adverse condition can happen to the LCD module which is assembled to the system when the external shock is applied to the system in the event that the bracket is not placed with being laid across on the LCD module.
- E. It is recommended to place the system bracket to cover the two sides of module. The LCD module can be defected by the condition, which the rear is pressurized when the bracket is located in the center only.
- F. If you don't follow the design for bracket as Samsung recommends, it is recommended to contact SAMSUNG to apply the engineering device.

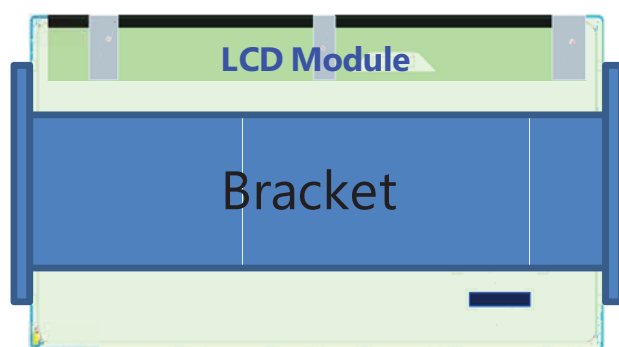

(Recommended)

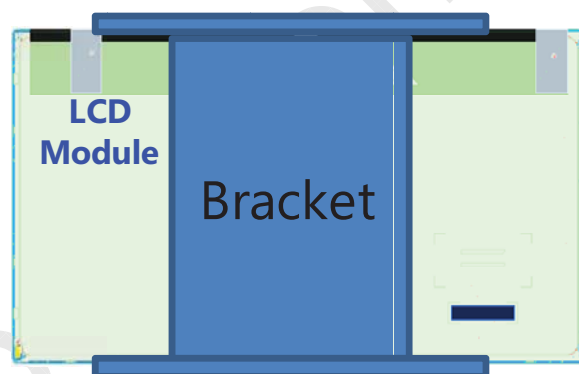

(Recommended)

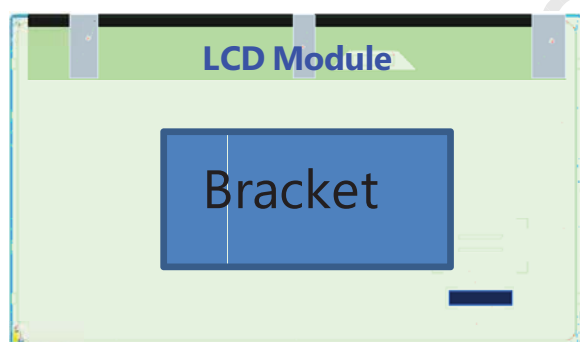

(Not recommended)

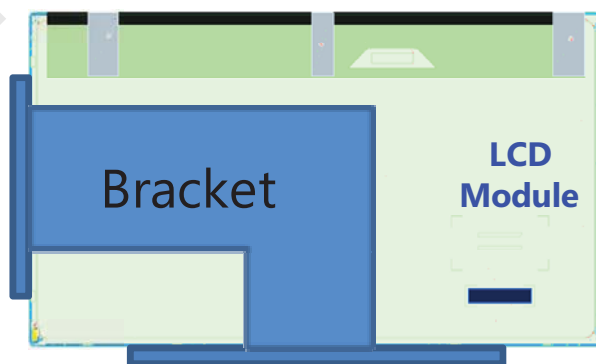

(Not recommended)

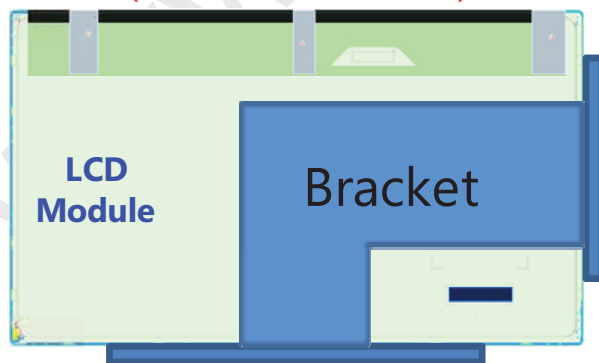

(Not recommended)