



Ceramic Filter - LTMW 455/450 Series

Pin Type - 6.5 x 9.5 x 6.2

• Features

Low cost

High performance

• General Specification

Part Number		Center Frequency	Insertion Loss	Passband Ripple	6dB Bandwidth	50dB Bandwidth	Spurious Attenuation fo±100kHz	Input/Output Impedance
		(fo)(kHz)	(dB)max	(dB)max	(kHz)min	(kHz)min	(dB) min	(Ω)
LTM455AW	LTM450AW	455±1.5	4	2	±17.5	±35	40	1000
LTM455BW	LTM450BW	455±1.5	4	2	±15.0	±30	40	1500
LTM455CW	LTM450CW	455±1.5	4	2	±12.5	±25	40	1500
LTM455DW	LTM450DW	455±1.5	4	2	±10.0	±20	40	1500
LTM455EW	LTM450EW	455±1.5	4	2	±7.5	±15	40	1500
LTM455FW	LTM450FW	455±1.5	6	2	±6.0	±12	40	2000
LTM455GW	LTM450GW	455±1.5	6	2	±4.5	±10	40	2000
LTM455HW	LTM450HW	455±1.5	6	2	±3.0	±9.0	40	2000
LTM455IW	LTM450IW	455±1.5	6	2	±2.0	±7.5	60	2000
LTM455HTW	LTM450HTW	455±1.6	6	2	±3.0	±9	60	2000

Operating temperature range: -20 to +80 °C

Storage temperature range: -40 to +85 °C

• Marking

Part number

• Ordering Information

Part number

NEWXTAL - New Crystal

Website: www.newxtal.com

Email: sales@newxtal.com

Ceramic Filter - LTMW 455/450 Series

• Dimensions

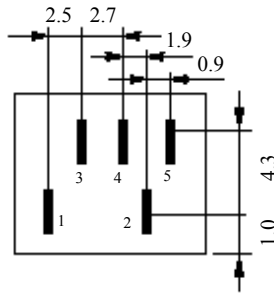
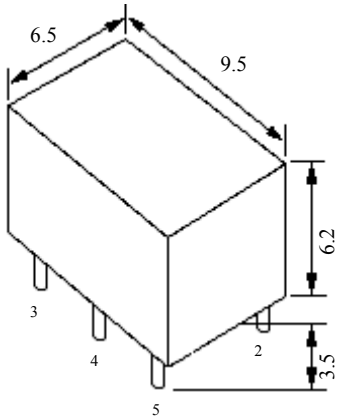

- 1. Input
- 2. Output
- 3. Ground
- 4. Ground
- 5. Ground

in mm

• Test Circuit

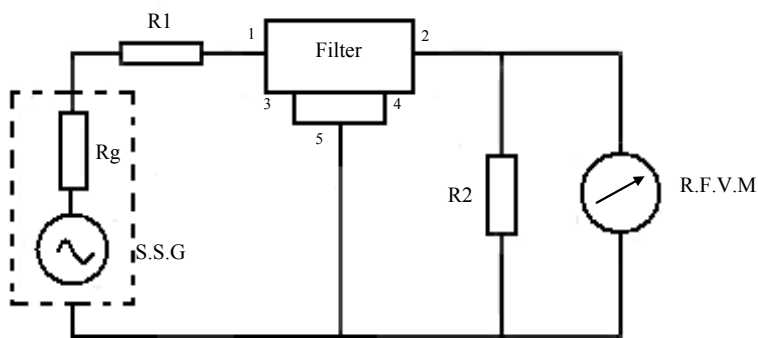

$$R_g + R_1 = R_2 = \text{Input/Output Impedance}$$

NEWXTAL - New Crystal

Website: www.newxtal.com

Email: sales@newxtal.com