



ELECTRONICS

Approval



TO : General
DATE : Nov.25. 2008

SAMSUNG TFT-LCD
MODEL NO : LTN089NT01

*Note: The product and specifications are subject to change without any notice.
Please ask for the latest Product Standards to guarantee the satisfaction of your product requirements.*

APPROVED BY : K. H. Shin

PREPARED BY : LCD Application Engineering Part (Mobile)

SAMSUNG ELECTRONICS CO., LTD.



Samsung Secret

Doc.No.	LTN089NT01	Rev.No	04-PI-S-081124	Page	1 / 27
---------	------------	--------	----------------	------	--------

Contents

Revision History

General Description

1. Absolute Maximum Ratings

- 1.1 Absolute Ratings Of Environment
- 1.2 Electrical Absolute Ratings

2. Optical Characteristics

3. Electrical Characteristics

- 3.1 TFT-LCD Module
- 3.2 Back-Light Unit

4. Block Diagram

- 4.1 TFT-LCD Block Diagram
- 4.2 Back-light Unit

5. Input Terminal Pin Assignment

- 5.1 TFT-LCD Module
- 5.2 Input Signal, Basic Display Colors and Gray Scale of Each Colors
- 5.3 Pixel Format

6. Interface Timing

- 6.1 Recommended Signal Timing
- 6.2 Timing Diagrams of LVDS for Transmission
- 6.3 Power up Sequence
- 6.4 EDID information

7. Outline Dimension

8. Packing(TBD)

- 8.1 Example of 8.9" WSVGA TFT-LCD

9. Marking & Others(TBD)

- 9.1 Product label attach
- 9.2 Packing case attach

10. General Precaution

- 10.1 Handling
- 10.2 Storage
- 10.3 Operation
- 10.4 Others



General Description

* Description

8.9" LCD is a transmissive type color active matrix TFT (Thin Film Transistor) liquid crystal display(LCD) that uses amorphous silicon TFT as a switching devices. This model is composed of a TFT-LCD module - a TFT-LCD panel, a driver IC, a FPC, a PCB and a Back-light unit. The resolution of a 8.9" contains 1024 x 600 pixels and can display up to 262K/16M colors.

* Features

- Triple-Gate Technology applied
- Transmissive type
- WSVGA(1024x600) resolution
- LEDs Back-light
- Dot/Column Inversion mode
- 6 bits/8 bits LVDS interface
- ROHS

* Applications

- UMPC(Ultra Mobile PC) application products
- Mini PC
- Portable CNS(P-CNS) and PMP(Portable Multimedia Player)

* General Information

Items	Specification	Unit	Note
Display area	195.07(H) x 113.4(V)	mm	-
Driver element	a-Si TFT active matrix	-	-
Display colors	262K/16M	colors	-
Color Gamut	45	%	-
Number of pixels	1024(H) x 600(V)	pixel	-
Pixel arrangement	RGB Horizontal stripe	-	-
Pixel pitch	0.1905(H) x 0.0630(V) x RGB	mm	-
Display mode	Normally White	-	-
Viewing Direction	6	o'clock	-

* Mechanical Information

Item	Min.	Typ.	Max.	Unit	Note	
Module size	Horizontal(H)	213.06	213.36	213.66	mm	(1)
	Vertical(V)	129.25	129.55	129.85	mm	(1)
	Depth(D)	4.85	5.15	5.45	mm	(1)
Weight	-	160	190	g	(1)	

Note (1) Back-light unit, mylar and PCB are included.



1. Absolute Maximum Ratings

1.1 Absolute Ratings of Environment

Item	Symbol	Min.	Max.	Unit	Note
Storage temperature	TSTG	-20	60	°C	(1)
Operating temperature (Ambient temperature)	TOPR	0	50	°C	(1),(2),(3)

Note (1) 90% RH Max. ($40\text{ }^{\circ}\text{C} \geq T_a$)

Maximum wet-bulb temperature at $39\text{ }^{\circ}\text{C}$ or less. ($T_a > 40\text{ }^{\circ}\text{C}$) No condensation.

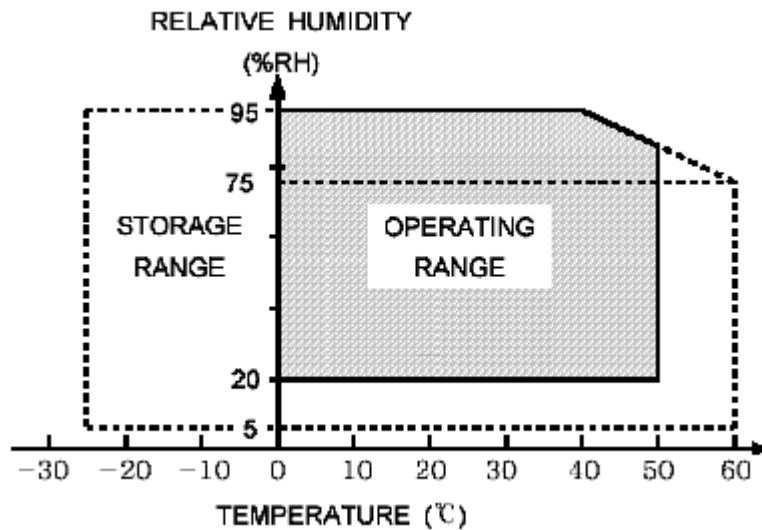

< Temperature & Humidity Graph at Absolute Environment >

Note (2) When operated at a temperature lower than $0\text{ }^{\circ}\text{C}$, the LCD worked slowly and the screen appeared low-contrast images due to the characteristics of LC (Liquid Crystal).

Note (3) If any fixed pattern is displayed on LCD for minutes, image-sticking phenomenon may occur.



1.2 Electrical Absolute Ratings

(1) TFT-LCD Module

(Ta = 25 ± 2°C)

Characteristics	Symbol	Min.	Max.	Unit	Note
Logic / LCD Voltage	VDD	2.7	3.6	V	(1)

Note (1) If used beyond absolute maximum ratings, the LSI may permanently be damaged. It is strongly recommended to use the LSI within the condition of electrical characteristics for normal operation. Exposure to a condition not within the electrical characteristics may affect the reliability of device.

(2) Back-Light Unit

(Ta = 25 ± 2°C)

Characteristics	Symbol	Min.	Max.	Unit	Note
LED Current	I _L	-	30	mA	(2)

Note (2) Permanent damage to the device may occur if maximum values are exceeded or reverse voltage is loaded. Functional operation should be restricted to the conditions described under normal operating conditions.



2. Optical Characteristics

The following items are measured under stable conditions. The optical characteristics should be measured in a dark room or equivalent state with the methods shown in Note (1), (2), (3).

* Measuring equipment: SR-3, BM-7, EZ-Contrast

(Ta = 25±2°C, VDD = 3.3V)

Item	Symbol	Condition	Min.	Typ.	Max.	Unit	Note	
Contrast ratio	C/R	B/L on (aver. 5p)	250	500	-	-	(4) SR-3	
Luminance of white	YL	I _L =20mA (aver. 5p)	170	200	-	cd/m ²	(5) SR-3	
NTSC Color Saturation	-	B/L on	40	45	-	%	-	
Response time	Rising:Tr	Tr+Tf	-	16	32	msec	(6) BM-7	
	Falling:Tf							
Color Chromaticity (CIE 1931)	White	Wx	Φ=0 θ=0 Normal Viewing Angle B/L On	(0.263)	0.313	(0.363)	-	(7) SR-3
		Wy		(0.279)	0.329	(0.379)		
	Red	Rx		(0.545)	0.595	(0.645)		
		Ry		(0.295)	0.345	(0.395)		
	Green	Gx		(0.270)	0.320	(0.370)		
		Gy		(0.505)	0.555	(0.605)		
	Blue	Bx		(0.100)	0.150	(0.200)		
		By		(0.095)	0.145	(0.195)		
Viewing angle	Hor.	qL	C/R≥10 B/L On	40	(50)	-	Degrees	(8) Ez-Contrast
		qR		40	(50)	-		
	Ver.	fH		15	(25)	-		
		fL		30	(40)	-		
White uniformity	B _{uni}	(13points)	62.5	80	-	%	(9) SR-3	



Note (1) The optical characteristics is measured with Back-light.

Note (2) If product is exposed to high temperatures for accelerated lift test or extended time, there is a possibility of the W/V polarizer film damage which could degrade the optical characteristics(Contrast ratio). But, Nothing is the matter in room temperature.

Note (3) Test Equipment Setup for the Transmissive Mode (Back-light On)

After stabilizing and leaving the panel alone at a given temperature for 30 sec, the measurement should be executed. Measurement should be executed in a stable, windless, and dark room. This should be measured in the center of screen.

- Back-light Current : $I_L=20 \text{ mA}$
- Back-Light On condition

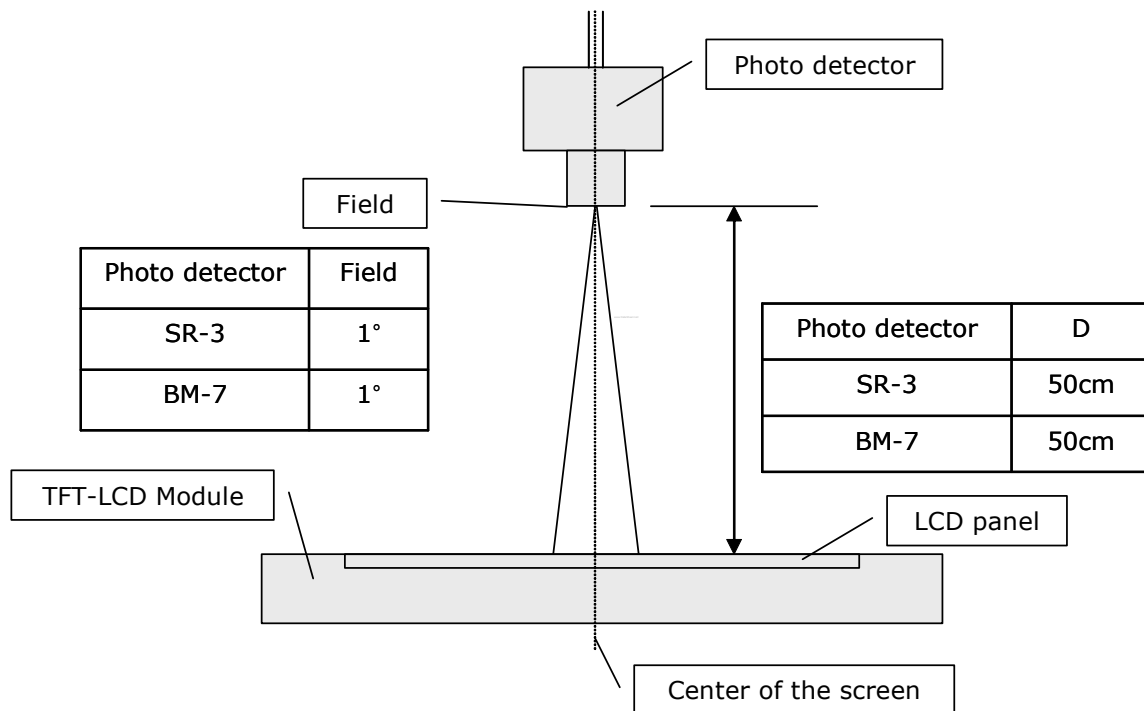

Note (4) Definition of Contrast Ratio (C/R) : Ratio of gray max (Gmax) & gray min (Gmin) of 5 points of the panel. (4, 5, 7, 9, 10 of Note(9))

If Back-light is on state, it is the light source and the SR-3 will be used to measure.

$$C/R = \frac{G_{max}}{G_{min}}$$

* Gmax : Luminance with all pixels white

* Gmin : Luminance with all pixels black



Note (5) Definition of Luminance of White : (Average) Luminance of white at 5 points.
 (4, 5, 7, 9, 10 of Note(9))

In this case, the incident light is not from the light source but from the Back-light that generates the reflected light source on LCD in the dark room.

Note (6) Definition of Response time : Sum of T_r, T_f

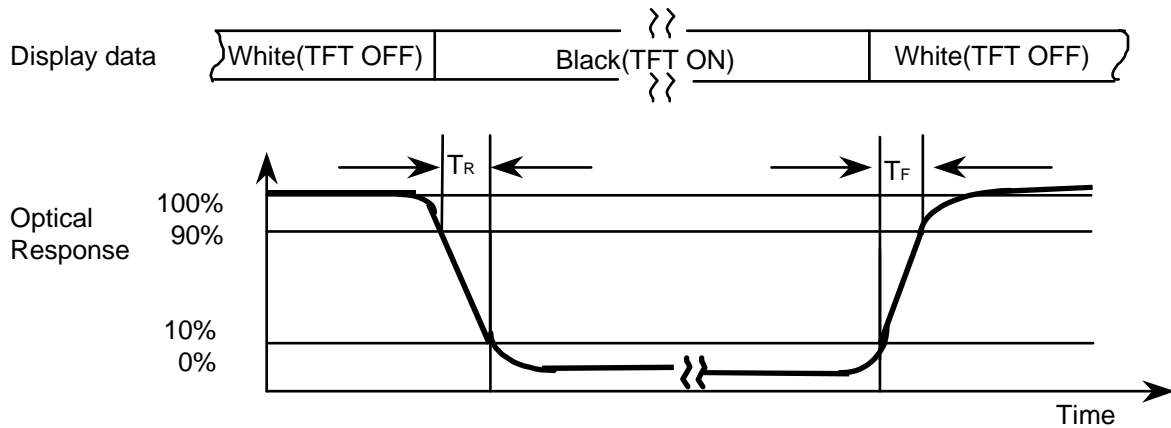

Note (7) Definition of Color Chromaticity (CIE 1931), (Back-light: On)

It should be measured with standard light source or single rank of LED.

Note (8) Definition of Viewing Angle : Viewing angle range

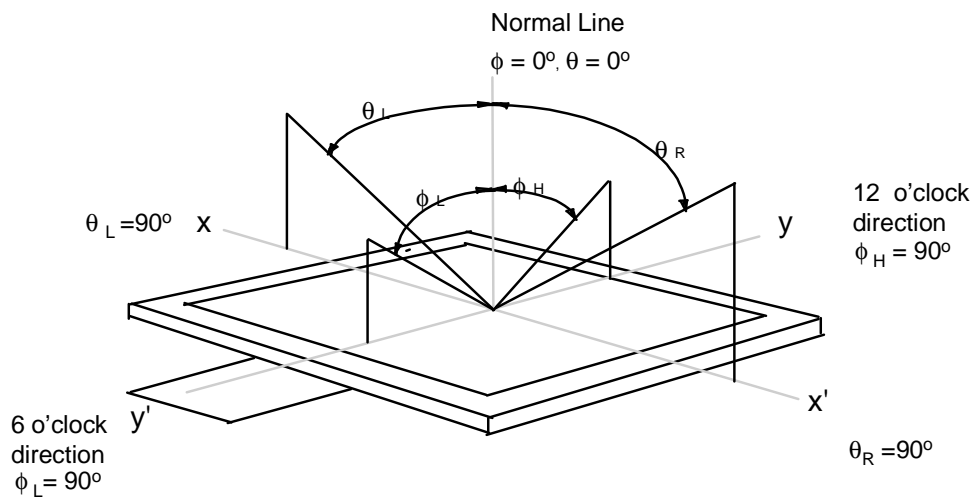

Note (9) Definition of Uniformity

$$\text{White Uniformity (\%)} = \frac{\text{Min. luminance of white among 13-points}}{\text{Max. luminance of white among 13-points}} \times 100$$

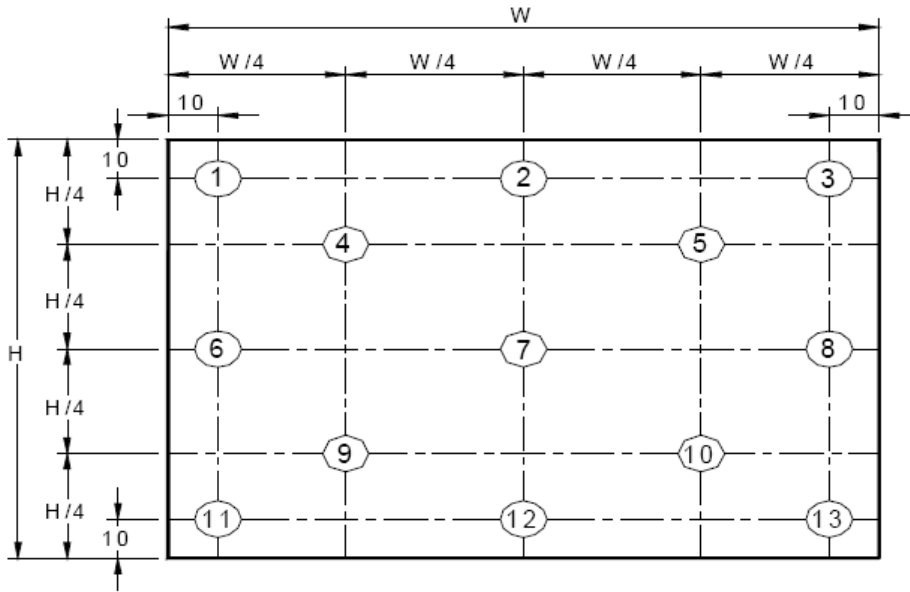

< The spot locations for luminance measurement >



3. Electrical Characteristics

3.1 TFT-LCD Module

(Ta = -20°C ~ 60°C)

Characteristics	Symbol	Min.	Typ.	Max.	Unit	Note	
Voltage of Power Supply	VDD	2.7	3.3	3.6	V		
Differential Input Voltage for LVDS Receiver Threshold	High	VIH	-	+100	mV	(1)	
	Low	VIL	-100	-	mV		
Vsync Frequency	fv	(55)	(60)	(65)	Hz	-	
Hsync Frequency	fH	-	(37.2)	-	KHz	-	
Main Frequency	fDCK	(43.6)	(47.6)	(51.6)	MHz	-	
Rush Current	IRUSH	-	-	(1.5)	A	(3)	
Current of Power Supply	White	IDD	-	(138)	-	mA	(2),(4)
	Mosaic		-	(140)	-	mA	
	Black		-	(150)	-	mA	

Note (1) Condition : VCM = +1.2V (Common mode Voltage)

(2) fv=60Hz, VDD=3.3V, DC Current

(3) Rush current measurement condition

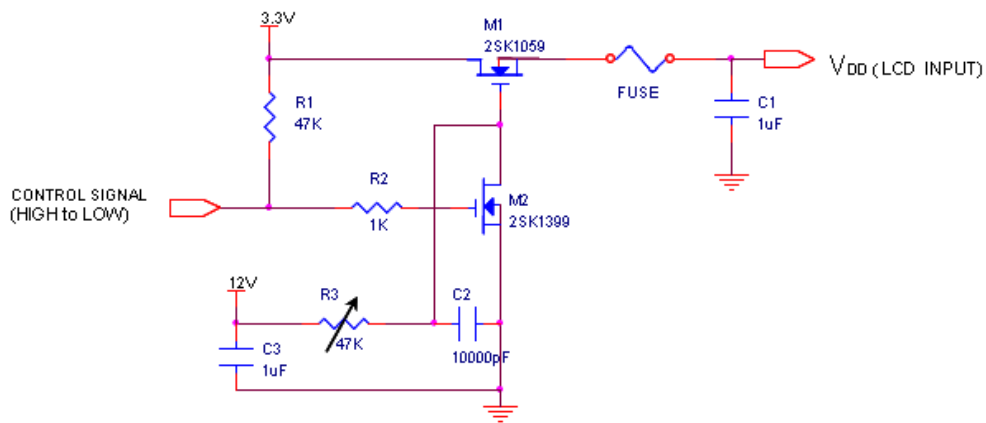

VDD rising time is 470us

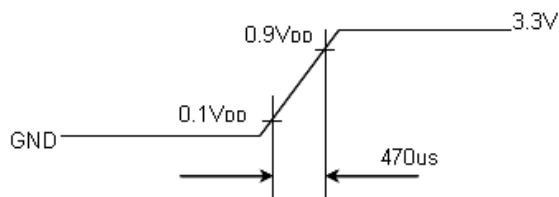

Note (4) Power dissipation check pattern

*a) White Pattern

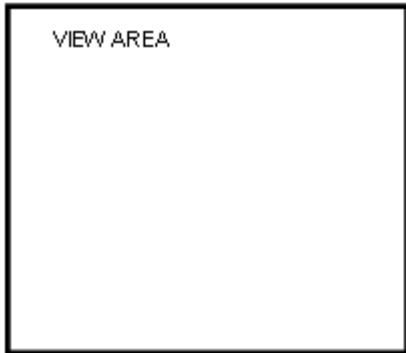

*b) Mosaic Pattern

Display Brightest Gray Level →

Display Darkest Gray Level →

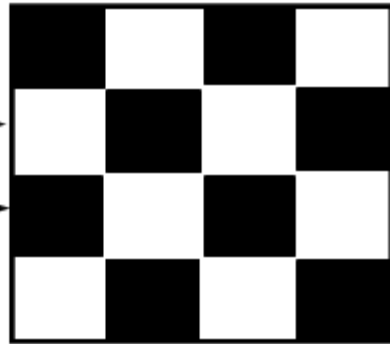

*c) Black pattern



3.2 Back-Light Unit

The Back-light system is an edge-lighting type with 24 white LED(Light Emitting Diode)s.
The characteristics of 24 white LEDs are shown in the following tables.

(Ta=25 ± 2°C)

Characteristics	Symbol	Min.	Typ.	Max.	Unit	Note
LED Power Voltage	VLED	4.5	5	5.5	V	(1)
LED Power Current	ILED		380	420	mA	Input=5V
LED PWM Frequency	L _{freq}	-	-	1K	Hz	-

Note (1) The LEDs parallel type (Refer to 4.2)

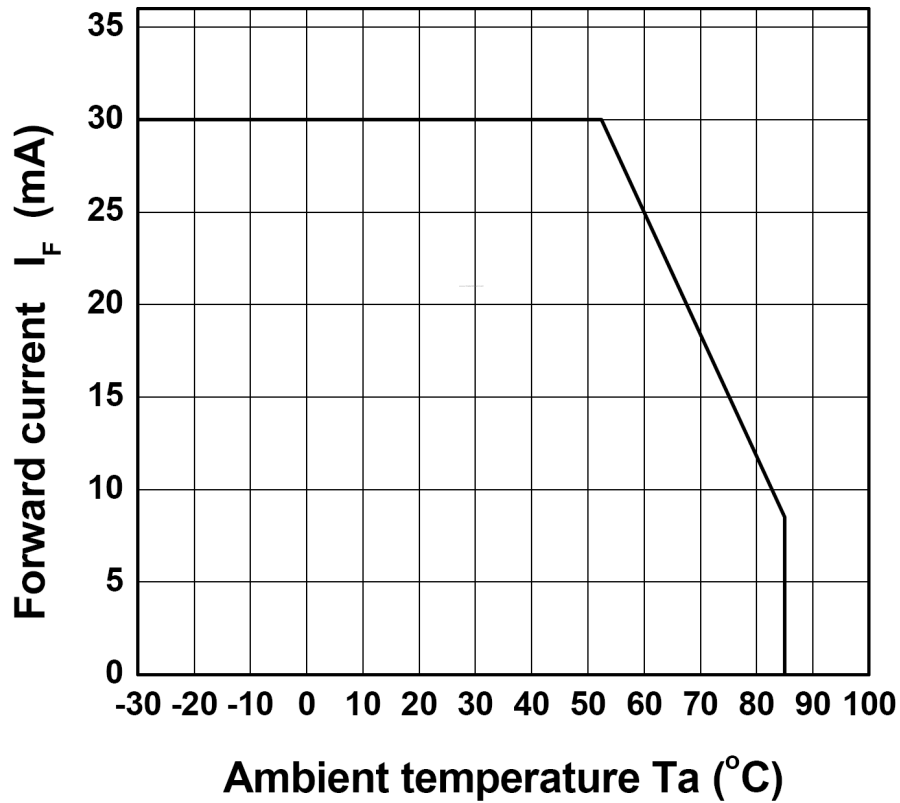

4. Block Diagram

4.1 TFT-LCD Block Diagram

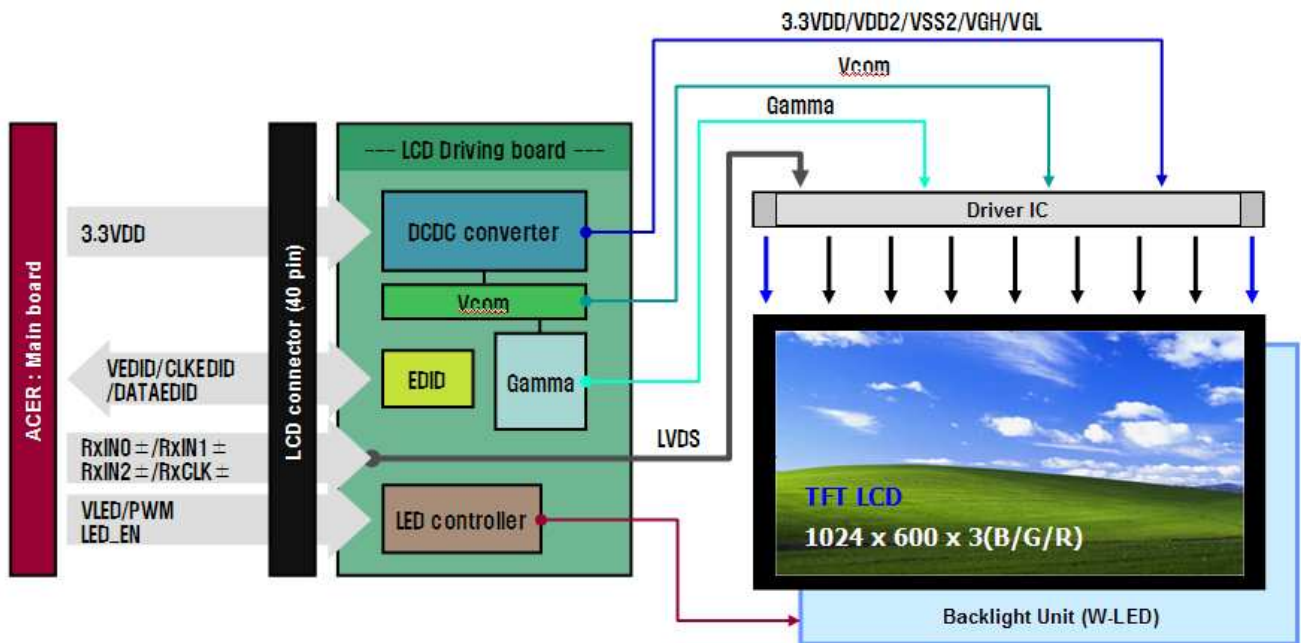

4.2 Back-light Unit

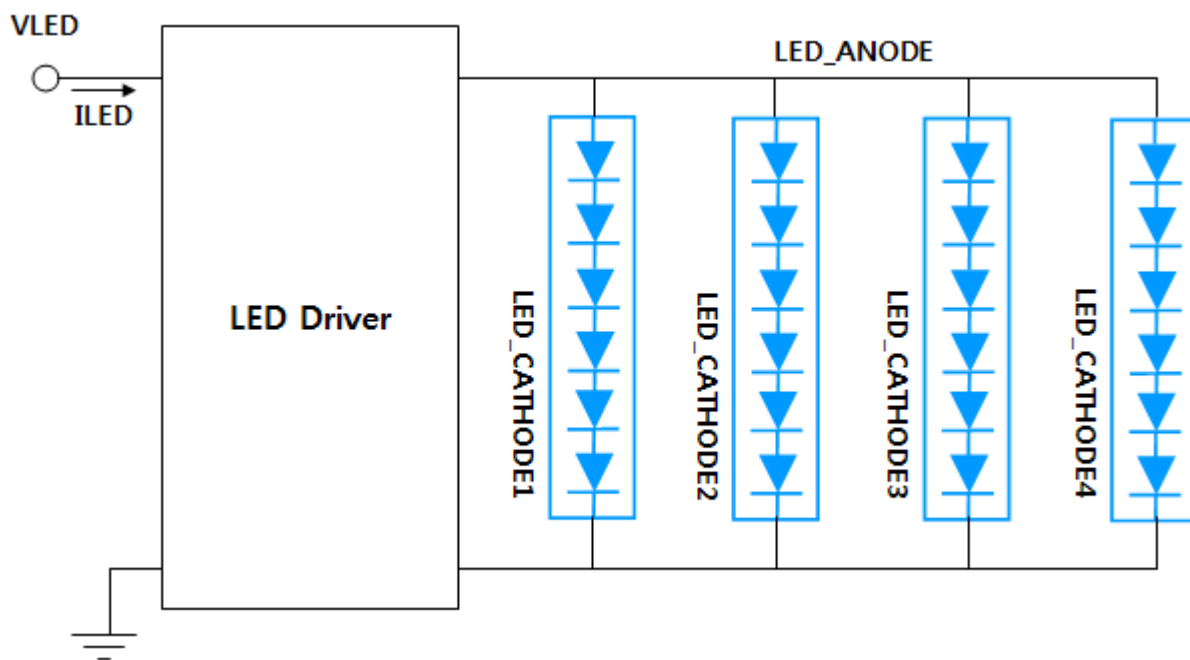

5. Input Terminal Pin Assignment

5.1 TFT-LCD Module (Connector : IPEX 20347-340E-12 or equivalent)

Pin No	Symbol	Description	Remark
1	GND	GROUND	
2	3.3VDD	3.3V POWER SUPPLY	
3	3.3VDD	3.3V POWER SUPPLY	
4	VEDID	3.3V EDID POWER	
5	NC	NO CONNECT	
6	CLKEDID	EDID CLK INPUT	
7	DATAEDID	EDID DATA INPUT	
8	RxIN0-	LVDS Differential Data Input	
9	RxIN0+	LVDS Differential Data Input	
10	GND	GROUND	
11	RxIN1-	LVDS Differential Data Input	
12	RxIN1+	LVDS Differential Data Input	
13	GND	GROUND	
14	RxIN2-	LVDS Differential Data Input	
15	RxIN2+	LVDS Differential Data Input	
16	GND	GROUND	
17	RxCLKIN-	LVDS Differential CLOCK Input	
18	RxCLKIN+	LVDS Differential CLOCK Input	
19	GND	GROUND	
20	NC	NO CONNECT	
21	NC	NO CONNECT	
22	GND	GROUND	
23	NC	NO CONNECT	
24	NC	NO CONNECT	
25	GND	GROUND	
26	NC	NO CONNECT	
27	NC	NO CONNECT	
28	GND	GROUND	
29	VLED	5V LED POWER SUPPLY	
30	VLED	5V LED POWER SUPPLY	
31	GND	GROUND	
32	GND	GROUND	
33	GND	GROUND	
34	NC	NO CONNECT	



Pin No	Symbol	Description	Remark
35	NC	NO CONNECT	
36	NC	NO CONNECT	
37	NC	NO CONNECT	
38	PWM	SYSTEM PWM SIGNAL INPUT	
39	NC/ENB	NO CONNECT or ENB pin INPUT	
40	NC	NO CONNECT	



5.2 Input Signal, Basic Display Colors and Gray Scale of Each Colors

< It depends upon LC operation mode >

COLOR	DISPLAY	DATA SIGNAL																	GRAY SCALE LEVEL
		BLUE					GREEN					RED							
		B0	B1	B2	B3	B4	B5	G0	G1	G2	G3	G4	G5	R0	R1	R2	R3	R4	
BASIC COLOR	BLACK	0	0	0	0	0	0	0	0	0	0	0	0	0	0	0	0	0	-
	BLUE	1	1	1	1	1	1	0	0	0	0	0	0	0	0	0	0	0	-
	GREEN	0	0	0	0	0	0	1	1	1	1	1	1	0	0	0	0	0	-
	CYAN	1	1	1	1	1	1	1	1	1	1	1	1	0	0	0	0	0	-
	RED	0	0	0	0	0	0	0	0	0	0	0	0	1	1	1	1	1	-
	MAGENTA	1	1	1	1	1	1	0	0	0	0	0	0	1	1	1	1	1	-
	YELLOW	0	0	0	0	0	0	1	1	1	1	1	1	1	1	1	1	1	-
	WHITE	1	1	1	1	1	1	1	1	1	1	1	1	1	1	1	1	1	-
GRAY SCALE OF BLUE	BLACK	0	0	0	0	0	0	0	0	0	0	0	0	0	0	0	0	0	B0
	DARK ↑	B1	1	0	0	0	0	0	0	0	0	0	0	0	0	0	0	0	B1
		B2	0	1	0	0	0	0	0	0	0	0	0	0	0	0	0	0	B2
		B3~B60	:	:	:	:	:	:	:	:	:	:	:	:	:	:	:	:	:
	LIGHT ↓	B61	1	0	1	1	1	1	0	0	0	0	0	0	0	0	0	0	B61
		B62	0	1	1	1	1	1	0	0	0	0	0	0	0	0	0	0	B62
		B63	1	1	1	1	1	1	0	0	0	0	0	0	0	0	0	0	B63
	GRAY SCALE OF GREEN	BLACK	0	0	0	0	0	0	0	0	0	0	0	0	0	0	0	0	0
DARK ↑		G1	0	0	0	0	0	0	1	0	0	0	0	0	0	0	0	0	G1
		G2	0	0	0	0	0	0	0	1	0	0	0	0	0	0	0	0	G2
		G3~G60	:	:	:	:	:	:	:	:	:	:	:	:	:	:	:	:	:
LIGHT ↓		G61	0	0	0	0	0	0	1	0	1	1	1	1	0	0	0	0	G61
		G62	0	0	0	0	0	0	0	1	1	1	1	1	0	0	0	0	G62
		G63	0	0	0	0	0	0	1	1	1	1	1	1	0	0	0	0	G63
GRAY SCALE OF RED		BLACK	0	0	0	0	0	0	0	0	0	0	0	0	0	0	0	0	0
	DARK ↑	R1	0	0	0	0	0	0	0	0	0	0	0	0	1	0	0	0	R1
		R2	0	0	0	0	0	0	0	0	0	0	0	0	0	1	0	0	R2
		R3~R60	:	:	:	:	:	:	:	:	:	:	:	:	:	:	:	:	:
	LIGHT ↓	R61	0	0	0	0	0	0	0	0	0	0	0	0	1	0	1	1	R61
		R62	0	0	0	0	0	0	0	0	0	0	0	0	0	1	1	1	R62
		R63	0	0	0	0	0	0	0	0	0	0	0	0	1	1	1	1	R63

Note (1) Definition of Gray

Rn : Red Gray, Gn : Green Gray, Bn : Blue Gray (n = Gray level)

Input Signal : 0 = Low level voltage, 1 = High level voltage



5.3 Pixel Format

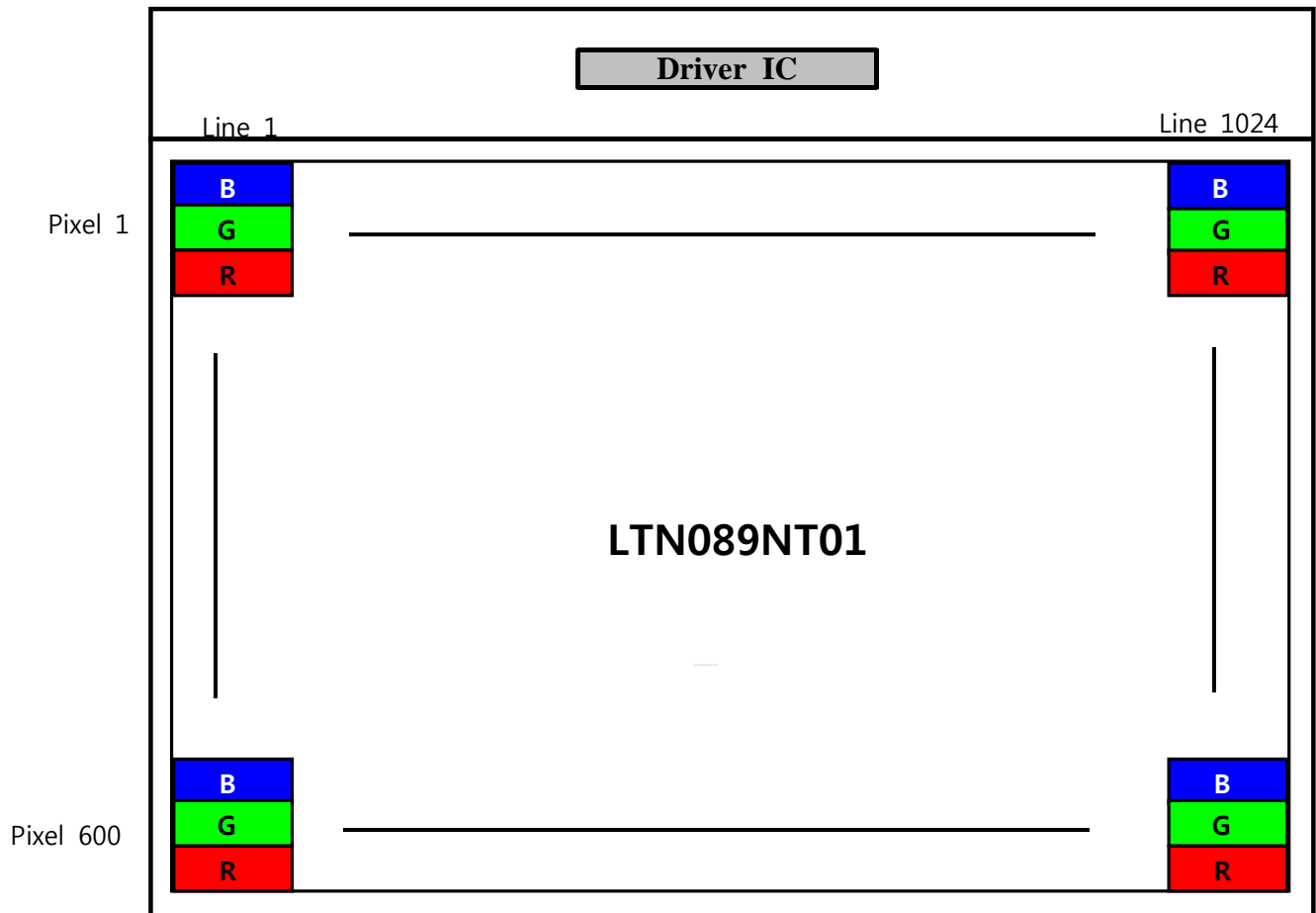

6. Interface Timing

6.1 Recommended Signal Timing

Signal	Item	Symbol	MIN	TYP	MAX	Unit	Note
Clock	Frequency	1/TC	-	(47.6)	-	MHz	
	Clock Pulse Width	TCW	TBD	(27.27)	-	nsec	
DATA	Setup Time	TDS	(2)	-	-	nsec	
	Hold Time	TDH	(0)	-	-	nsec	
Frame Frequency	Cycle	TV	-	16.7	-	msec	
			-	60	-	Hz	
Vertical Active Display Term	Display Period	TVD	-	600	-	lines	
	Vertical Blank Period	TVB	-	(20)	-	lines	
One Line Scanning Time	Cycle	TH	-	(1200)	-	clock	
Horizontal Active Display Term	Display Period	THD	-	1024	-	clock	

6.2 Timing Diagrams of LVDS for Transmission

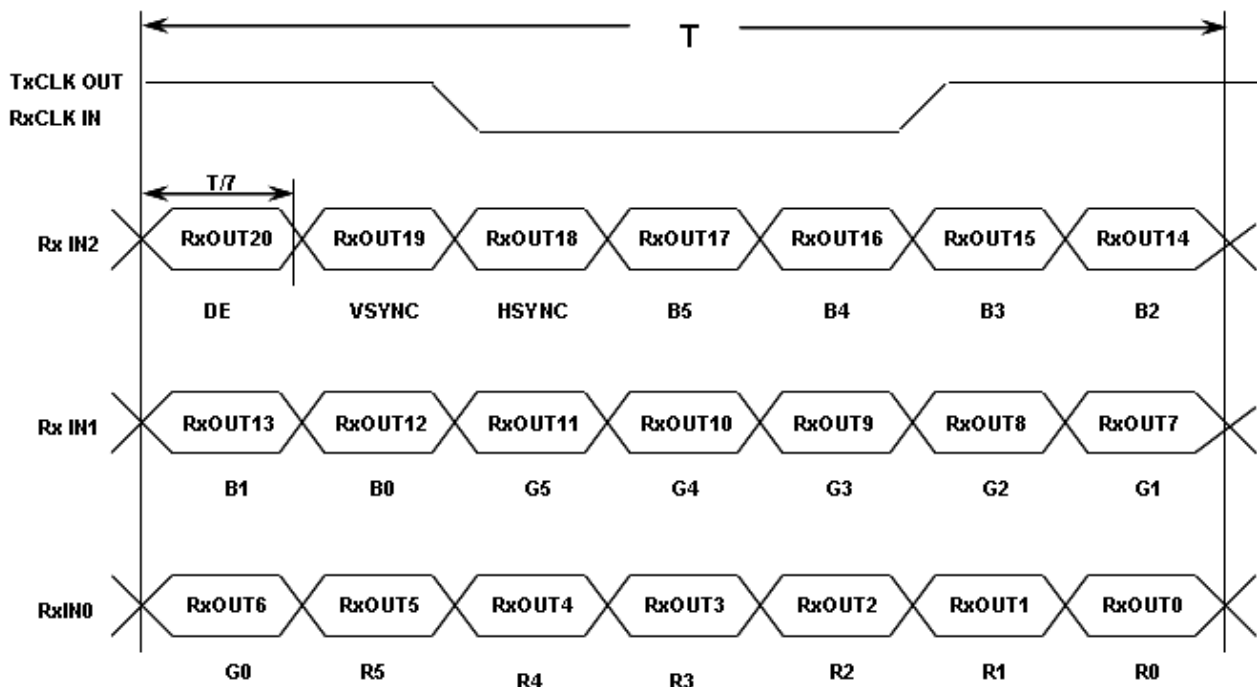

6.3 Power On/Off Sequence

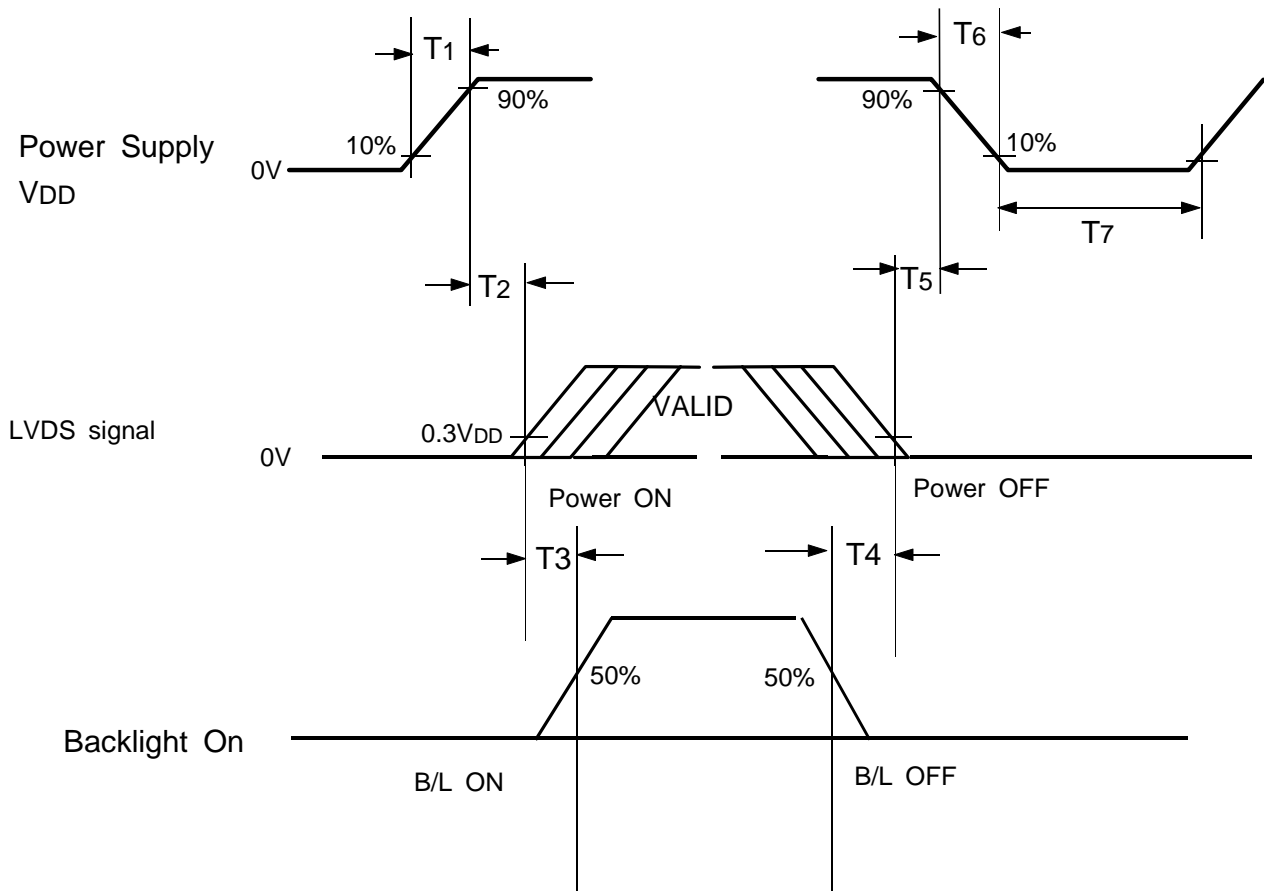

Parameter	Value			Unit
	Min.	Typ.	Max.	
T1	0.5	-	10	(ms)
T2	10	30	50	(ms)
T3	200	-	-	(ms)
T4	200	-	-	(ms)
T5	0	16.7	50	(ms)
T6	0	-	10	(ms)
T7	1000	-	-	(ms)

< Power Sequence timing >

- Note (1) The supply voltage of the external system for the module input should be the same as the definition of VDD.
- Note (2) Apply the lamp voltage within the LCD operation range. When the back-light turns on before the LCD operation or the LCD turns off before the Back-light turns off, the display may momentarily become white.
- Note (3) T4 should be measured after the module has been fully discharged between power off and on period.
- Note (4) Interface signal shall not be kept at high impedance when the power is on.



7. Outline Dimension

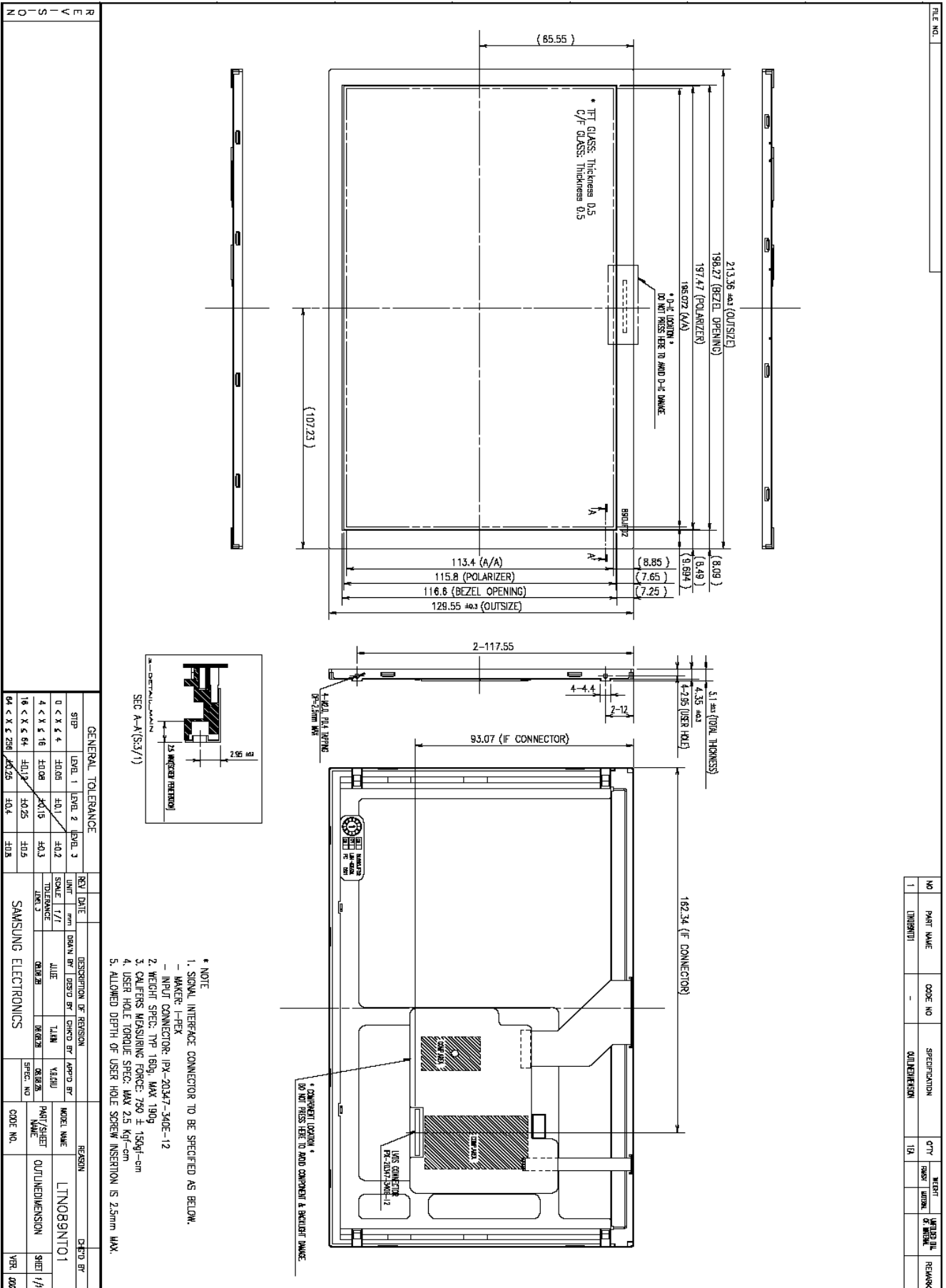

NO	PART NAME	CODE NO	SPECIFICATION	QTY	UNIT	REMARK
1	UNIBRNT01	-	OUTLINE DRAWING	1/1	1/1	

- * NOTE
1. SIGNAL INTERFACE CONNECTOR TO BE SPECIFIED AS BELOW.
- MAKER: I-REX
- INPUT CONNECTOR: PX-20347-340E-12
 2. WEIGHT SPEC: TYP: 80g, MAX: 100g
 3. CALIFERS MEASURING FORCE: 750 ± 1.50gf-cm
 4. USER HOLE TORQUE SPEC: MAX 2.5 kgf-cm
 5. ALLOWED DEPTH OF USER HOLE SCREW INSERTION IS 2.5mm MAX.

GENERAL TOLERANCE				REV	DATE	DESCRIPTION OF REVISION	REASON	CHG BY
STEP	LEVEL 1	LEVEL 2	LEVEL 3	UNIT	SCALE	T/1	VALU	
0 < X & 4	±0.05	±0.1	±0.2	mm	1/1			LTN089NT01
4 < X & 16	±0.08	±0.15	±0.3					
16 < X & 64	±0.1	±0.25	±0.5					
64 < X & 256	±0.25	±0.4	±0.8					

REV	NO	DATE	DESCRIPTION
1	1		



8. Packing(TBD)

8.1 Example of 8.9" WSVGA TFT-LCD

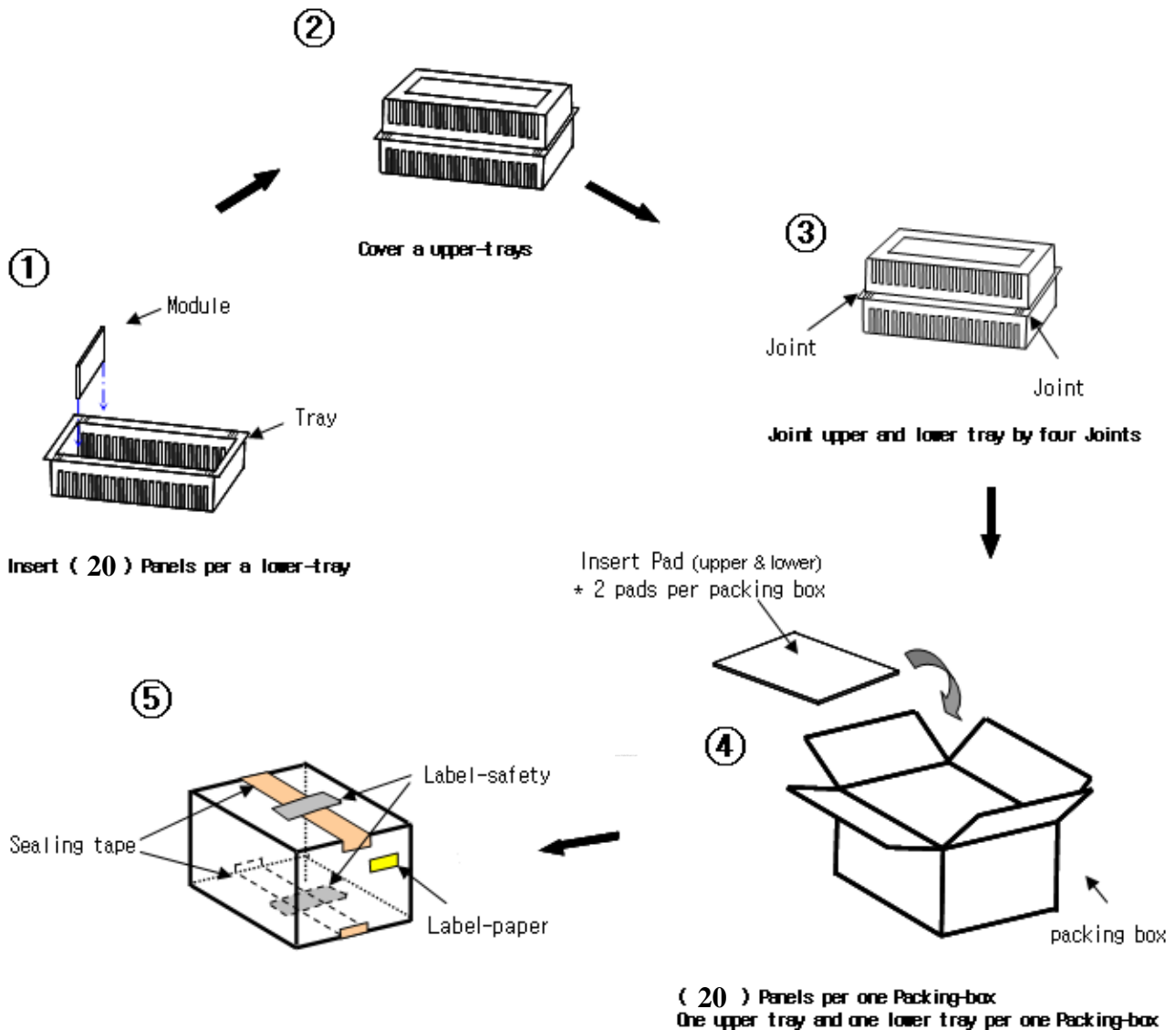

- Note (1) Total : Box Approx. TBD Kg
(2) Size : Box 505(W) x 355(D) x 312(H)
(3) Place the panels in the tray facing the direction shown in the figure.
(4) Place 1 packing-case inside the packing-box.
(5) Seal the packing-box. Affix the label-safety.
(6) Place 36 packing-box inside 1 pallet.



9. Marking & Others

9.1 Product label attach

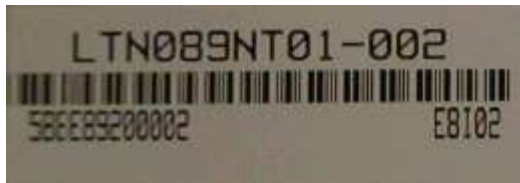

9.2 Packing case attach

A nameplate bearing followed by is affixed to a shipped product at the Specified location on each product.

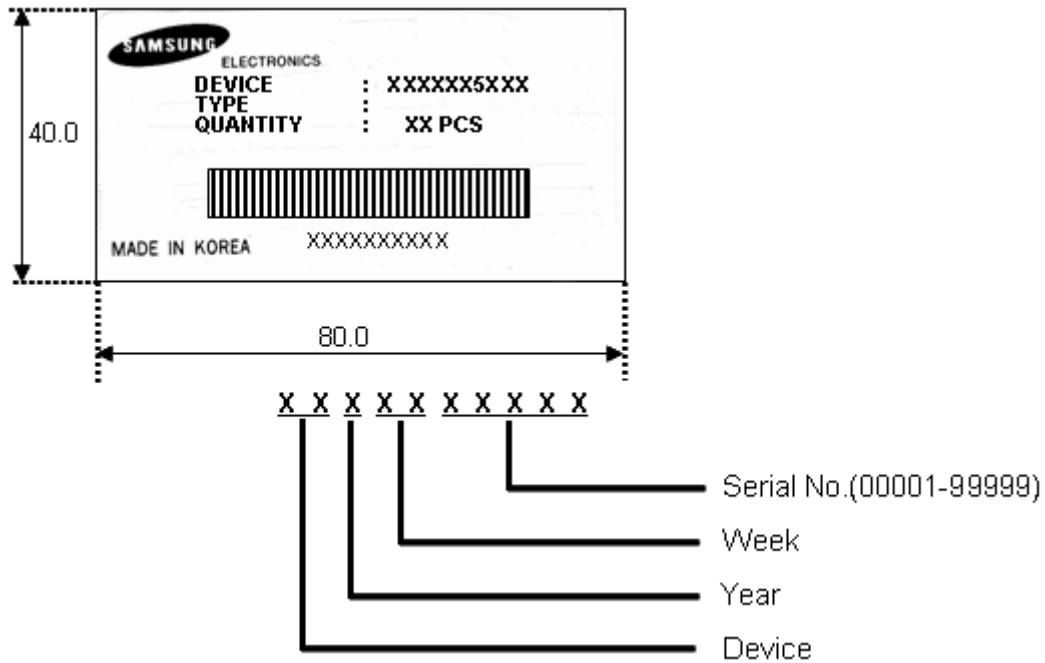

10. General Precautions

10.1 Handling

- (a) When the module is assembled, it should be attached to the system firmly. Be careful not to twist and bend the module.
- (b) Refrain from strong mechanical shock and / or any force to the module. In addition to damage, this may cause improper operation or damage to the module and back-light unit.
- (c) Note that polarizers are very fragile and could be easily damaged. Do not press or scratch the surface harder than a HB pencil lead.
- (d) Wipe off water droplets or oil immediately. If you leave the droplets for a long time, Staining and discoloration may occur.
- (e) If the surface of the polarizer is dirty, clean it using some absorbent cotton or soft cloth.
- (f) The desirable cleaners are water, IPA(Isopropyl Alcohol) or Hexane. Do not use Kepton type materials(ex. Acetone), Ethyl alcohol, Toluene, Ethyl acid or Methyl chloride. It might permanent damage to the polarizer due to chemical reaction.
- (g) If the liquid crystal material leaks from the panel, it should be kept away from the eyes or mouth. In case of contact with hands, legs or clothes, it must be washed away thoroughly with soap.
- (h) Protect the module from static, it may cause damage to the Integrated Gate Circuit.
- (i) Use finger-stalls with soft gloves in order to keep display clean during the incoming inspection and assembly process.
- (j) Do not disassemble the module.
- (k) Protection film for polarizer on the module shall be slowly peeled off just before use so that the electrostatic charge can be minimized.
- (l) Pins of I/F connector shall not be touched directly with bare hands.

10.2 Storage

- (a) Do not leave the panel in high temperature, and high humidity for a long time. It is highly recommended to store the module with temperature from 0 to 35°C and relative humidity of less than 70%.
- (b) Do not store the TFT-LCD module in direct sunlight.
- (c) The module shall be stored in a dark place. It is prohibited to apply sunlight or fluorescent light during the store.



10.3 Operation

- (a) Do not connect, disconnect the module in the "Power On" condition.
- (b) Power supply should always be turned on by the item 6.3. Power up sequence"

10.4 Others

- (a) The liquid-crystal is deteriorated by ultraviolet rays. Do not leave it in direct sunlight and strong ultraviolet rays for many hours.
- (b) Avoid condensation of water. It may result in improper operation or disconnection of electrode.
- (c) Do not exceed the absolute maximum rating value. (the supply voltage variation, input voltage variation, variation in part contents and environmental temperature, and so on) Otherwise the panel may be damaged.
- (d) If the panel displays the same pattern continuously for a long period of time, it can be the situation when the image "Sticks" to the screen.
- (e) This panel has its circuitry FPC on the bottom side and should be handled carefully in order not to be stressed.
- (f) If product is exposed to high temperatures for accelerated lift test or extended time, there is a possibility of the W/V polarizer film damage which could degrade the optical characteristics(Contrast ratio). But, Nothing is the matter in room temperature.

