

제품 표준

(LTN101AL03-801)

대상 제품	LTN101AL03-801		
승인정보	작성자	승인자	REV No.
	박상헌	편승범	V01
	2011.04.14		

목차

1. 개정 내역	-----	(3)
2. 일반 개요	-----	(4)
3. 절대 정격	-----	(5)
3.1 환경 절대 정격		
3.2 전기적 절대 정격		
4. Block Diagram	-----	(6)
5. 전기적 특성	-----	(7)
5.1 TFT LCD Module		
5.2 Back Light Unit		
6. 입력 사양	-----	(9)
6.1 입력 Pin 사양		
6.2 LVDS 입력 사양		
6.3 Interface Timing		
6.4 입력신호와 표시색상과의 관계		
6.5 PANEL상의 화소 표시위치		
6.6 Power sequence		
7. 광학적 특성	-----	(16)
8. 기구적 특성	-----	(22)
9. Label 및 포장 사양	-----	(23)
9.1 Label 사양		
9.2 포장 사양		
10. GENERAL PRECAUTION	-----	(24)

1. 개정 내역

개정일	Rev No.	개정자	개정 Page	개정 내용
11..04.05	00	이경모		최초 제정
11.04.14	01	박상헌	7 8 21	- Paenl 소비전력 SPEC 오류 정정 - BLU 소비전력 SPEC 오류 정정 - Crosstalk 측정 Note(6) 제거

2. 일반 개요

2.1 목적

제품 정보를 정의하고, 이를 부서간에 공유하기 위함.

2.2 관련표준

SQ00029 LCD 신뢰성 불량 판정 품질 표준

2.3 적용범위

LTN101AL03-801 제품

2.4 제품 개요

2.4.1 개요

LTN101AL01-C01은 비정질 실리콘(Amorphous Silicon) 박막 트랜지스터(TFT;Thin Film Transistor)를 스위칭 소자로 이용한 컬러 능동 행렬(Color active matrix) 방식의 TFT 액정 표시소자(LCD;Liquid Crystal Display)이다. 이는 TFT LCD Panel, 구동회로부와 LED를 광원으로 하는 Back light부로 구성 된다.

LTN101AL01-C01 의 대각선은 1280X800 Pixel을 포함하고 16,777,216의 색상을 지원한다.

2.4.2 특징

- ① 얇고 가볍다.
- ② 높은 휘도 대비비, 넓은 시야각, 넓은 색표현 범위 특성
- ③ RoHS compliance
- ④ DE Only Mode
- ⑤ 3.3V 구동 전원

2.4.3 응용분야

- ① Tablet PC 화면 표시기
- ② Note PC용 화면 표시기

2.4.4 일반사양

(Ta=25±2 °C)

항목	사양	단위	비고
환경 안전 규제	Pb Free, Halogen Free		
유효표시면적	216.96(H) X 135.60(V) (10.1"diagonal)	mm	
표현가능색 수	16,777,216 색 (8bit)		
해상도	1280 x 800 (WXGA)	pixel	16:10
화소배열	RGB 수직 줄배열(RGB VERTICAL STRIPE)		
Pixel 크기	0.1695(H) x 0.1695(V)	mm	
표시모드	흑색바탕모드(Normally black), PLS Mode		
표면처리	CF : Glare / TFT : APCF		
표면경도	3H		
광원	W-LED		
백색 휘도	400	cd/m ²	Typ
Module 크기	229.5(H) * 149.8(V)	mm	Typ
두께	2.39	mm	Typ
무게	130 ± 10	g	Cpk : 1.92
응답속도	30	ms	Typ
소비 전력	LOGIC 0.74	W	Typ @White

3. 절대 정격

3.1 환경 절대 정격

ITEM	SYMBOL	MIN.	MAX.	UNIT	NOTE
Storage temperature	TSTG	-20	60	°C	(1)
Operating temperature	TOPR	-20	50	°C	(1)

NOTE (1) 온도와 상대습도 관계는 아래 그림에 따른다.

Ta<40°C일때 상대습도 95%RH MAX.

Ta≥40°C일때 최대습구온도(Maximum Wet Bulb)는 39°C 이하.

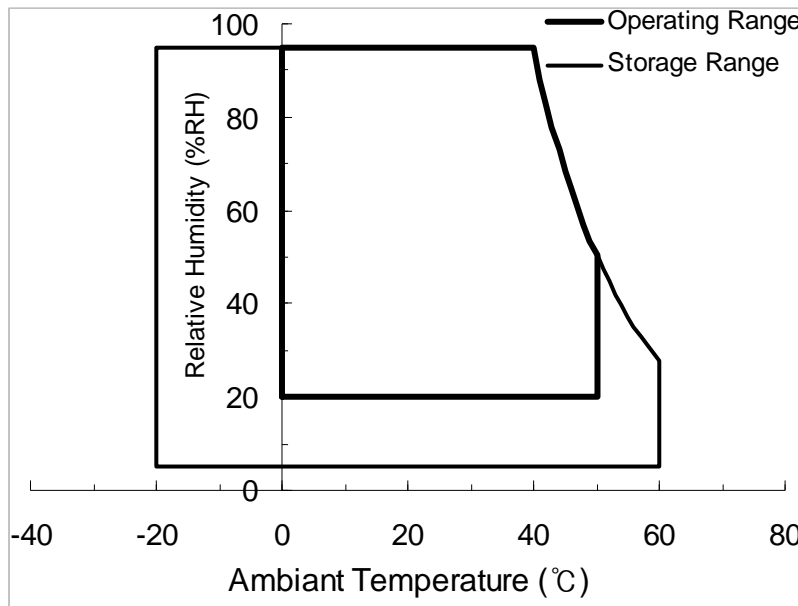

3.1.2 LCD 제품 보관 기준

ITEM	Unit	Min.	Max.
Storage Temperature	(°C)	5	40
Storage Humidity	(%rH)	35	75
Storage life	12 months		
Storage Condition	<ul style="list-style-type: none"> - . Prohibit direct sunlight - . Ventilation in storehouse and Control changing temperature is within limits of environment - . Put it on pallet, don' t put it on floor. and store them with removing form wall. - . Don't wet Out-BOX and avoid rain. - . Without condensation. - . Etc. Avoid harmful Condition. 		

3.1.3 장기 보관품 처리 기준

Long - term Storage Process	More than 3months Storage or Low temp. Delivery/under 5°C Storage, → On the 20°C 50%rH Condition , More than 10hr release.
-----------------------------	---

3.2 전기적 사양 절대 정격

3.2.1 입력 전압 및 BLU LED 전류

ITEM	SYMBOL	MIN.	MAX.	UNIT	NOTE
Power Supply Voltage	Vcc	-0.3	5	V	(1)
Logic Input Voltage (LVDS)	VLogic	-0.3	2.0	V	(1)
LED Current	ILED	-	35	mA	(2)

NOTE (1) 동작온도 범위 내에서.

(2) 외장형으로 1Ch당 LED Current.

4. Block Diagram

4.1 TFT LCD Module

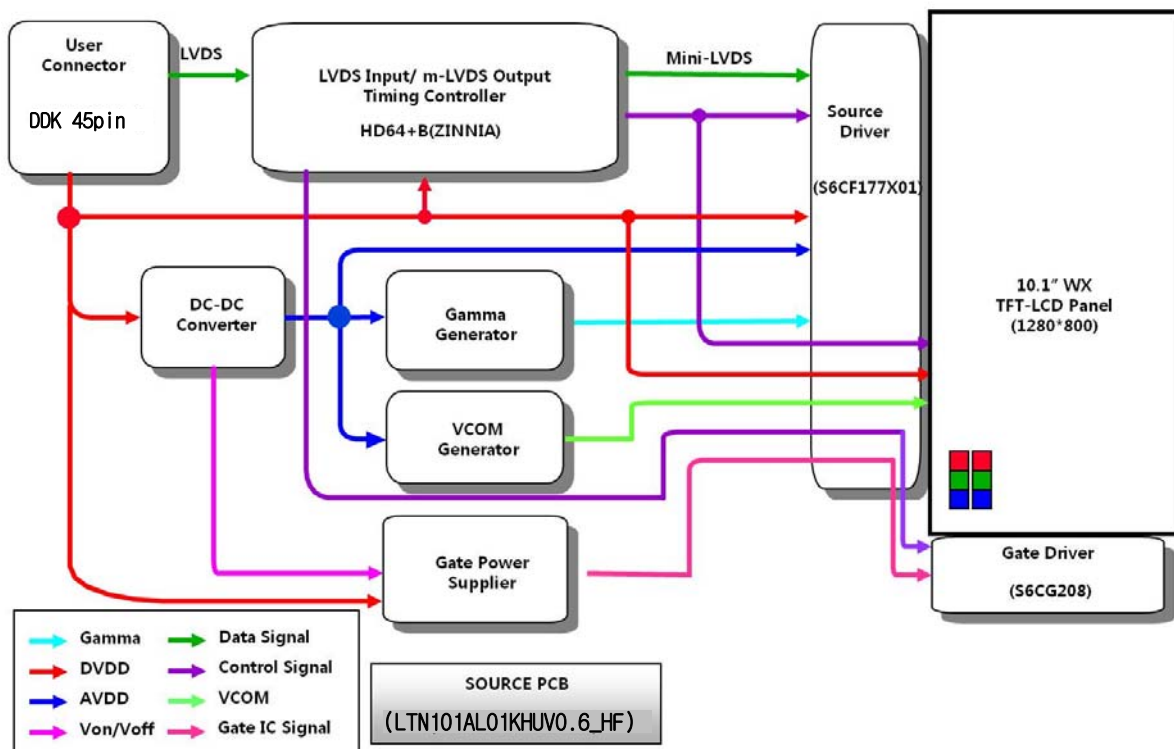

4.2 Back Light unit

String	LED1	LED2	LED3	LED4	LED5	LED6	LED7	LED8	LED9	LED10
1	1	2	3	4	5	6	7	8	9	10
2	11	12	13	14	15	16	17	18	19	20
3	21	22	23	24	25	26	27	28	29	30
4	31	32	33	34	35	36	37	38	39	40

LED Assignments on FPC String

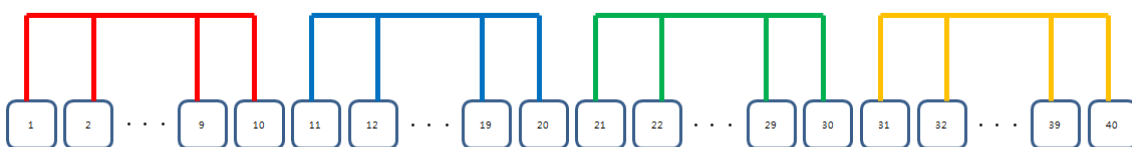

LED Connection On FPC

5. 전기적 특성

5.1 TFT LCD Module

(Ta=25±2 °C)

ITEM	SYMBOL	MIN.	TYP.	MAX.	UNIT	NOTE	
Power Supply Voltage	VCC	3.0	3.3	3.6	V		
Power Consumption	Panel	PCC	-	0.74	0.81	W	(2),(3)
	BLU	-	-	3.22	3.54		5.2.1참조
	Total	-	-	3.96	4.35	W	(2),(3),(4)
Differential input high threshold voltage	V _{TH}	-	-	100	mV	V _{CM} =1.2V	
Differential input high threshold voltage	V _{TH}	-100	-	-			
Vsync Frequency	fV	-	60	-	Hz		
Main Frequency	fDCLK	-	68.94	-	MHz	-	
Rush Current	IRUSH	-	-	1.5	A	(4)	

NOTE (1) 디스플레이 데이터 및 타이밍 신호용 콘넥터는 연결되어 있으며, 정상적인 화면 구동을 하고 있을 것 것(V_{SS} = 0V)

(2) f_v = 60Hz, f_{DCLK} = 68.94MHz, V_{CC} = 3.3 V, DC current

(3) 소비전력 체크 패턴



(White Pattern)

(4) Total Power consumption: Panel + BLU(With Driver) @91.8% Dimming

측정조건 (V_{CC} Rising time =470 μs)

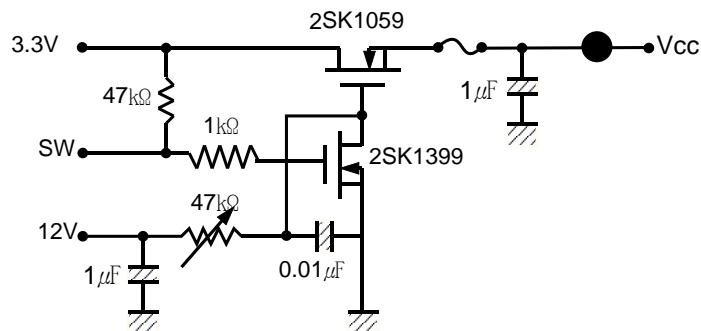

5.2 Back Light Unit

5.2.1 LED Ass'y

(Ta=25 °C)

ITEM	SYMBOL	MIN.	TYP.	MAX.	UNIT	NOTE
LED Forward Voltage	Vf	2.8	2.9	3.0	V	(1)
LED Forward Current	If	-	21	-	mA	-
BLU Power Consumption (Without LED Driver)	-	-	2.44	2.68	W	(3),(5)
BLU Power Consumption (With LED Driver Board)	-	-	3.22	3.54	W	(4),(5)
사용 LED 수	-	-	40	-	EA	(2)
LED 휘도	-	2400	2500	2600	mcd	(1)

NOTE (1) If = 21mA 일때

NOTE (2) 10EA x 4ch = 40EA

NOTE (3) LED Forward Voltage x LEDnumbers x LED Current

$$\rightarrow 2.9(v) \times 0.021(A) \times 40ea = 2.44W$$

NOTE (4) 외장형으로 23mA setting 된 Tablet Board V1.0 구동 Board에서 Duty 적용 측정

NOTE (5) PWM 92% (ILED=21mA)

6. 입력 사양

6.1.1 입력 Pin 사양 : Input Connector DDK 45PIN

No.	Symbol	Function	Polarity	Remarks
1	VSS	Ground		
2	VSS	Ground		
3	NC	NO CONNECT		
4	VDD	Power Supply +3.3V		Typ
5	VDD	Power Supply +3.3V		Typ
6	VDD	Power Supply +3.3V		Typ
7	VDD	Power Supply +3.3V		Typ
8	VDD	Power Supply +3.3V		Typ
9	WPN	WPN		
10	SCL	DVR_I2C CLK		
11	SDA	DVR_I2C Data		
12	VSS	Ground		
13	VSS	Ground		
14	VSS	Ground		
15	RxOIN3-	-LVDS Differential Data	Negative	
16	RxOIN3+	+LVDS Differential Data	Positive	
17	VSS	Ground		
18	RxOCKIN-	-LVDS Odd Differential CLK	Negative	CLOCK
19	RxOCKIN+	+LVDS Odd Differential CLK	Positive	
20	VSS	Ground		
21	RxOIN2-	-LVDS Differential Data	Negative	
22	RxOIN2+	+LVDS Differential Data	Positive	
23	VSS	Ground		
24	RxOIN1-	-LVDS Differential Data	Negative	
25	RxOIN1+	+LVDS Differential Data	Positive	
26	VSS	Ground		
27	RxOIN0-	-LVDS Differential Data	Negative	
28	RxOIN0+	+LVDS Differential Data	Positive	
29	VSS	Ground		
30	VSS	Ground		
31	NC	NO CONNECT		
32	FB1	Feedback1		
33	FB2	Feedback2		
34	FB3	Feedback3		
35	FB4	Feedback4		
36	NC	NO CONNECT		
37	NC	NO CONNECT		
38	NC	NO CONNECT		
39	VLED	BLU VCC		
40	VLED	BLU VCC		
41	VLED	BLU VCC		
42	VLED	BLU VCC		
43	VLED	BLU VCC		
44	NC	NO CONNECT		
45	VSS	Ground		

6.2 LVDS 입력 사양

6.2.1 LVDS DC 입력 사양

ITEM	SYMBOL	MIN.	TYP.	MAX.	UNIT	NOTE
LVDS Differential Voltage	VID	100	-	400	mV	
Input Common Mode Voltage	V_{CM}	0.6	0.8	1.0	V	
		0.8	1.2	1.4		

6.2.2 LVDS AC 입력 사양

ITEM	SYMBOL	MIN.	TYP.	MAX.	UNIT	NOTE	
LVDS input clock frequency	F_{CLK_LVDS}	20	-	90	MHz		
Modulating frequency of LVDS input clock during SSCG	F_{CLK_MOD}	-	-	300	KHz		
Maximum deviation of LVDS input clock frequency during SSCG	F_{CLK_DEV}	-	-	± 3	%		
RIN skew margin	$90MHz > F_{CLK_LVDS} \geq 65MHz$	$\Delta RSKM$	-400	-	400	ps	(1),(2)
	$65MHz > F_{CLK_LVDS} \geq 20MHz$		-600	-	600	ps	(1),(2)

Note (1) : LVDS Input Timing Diagram

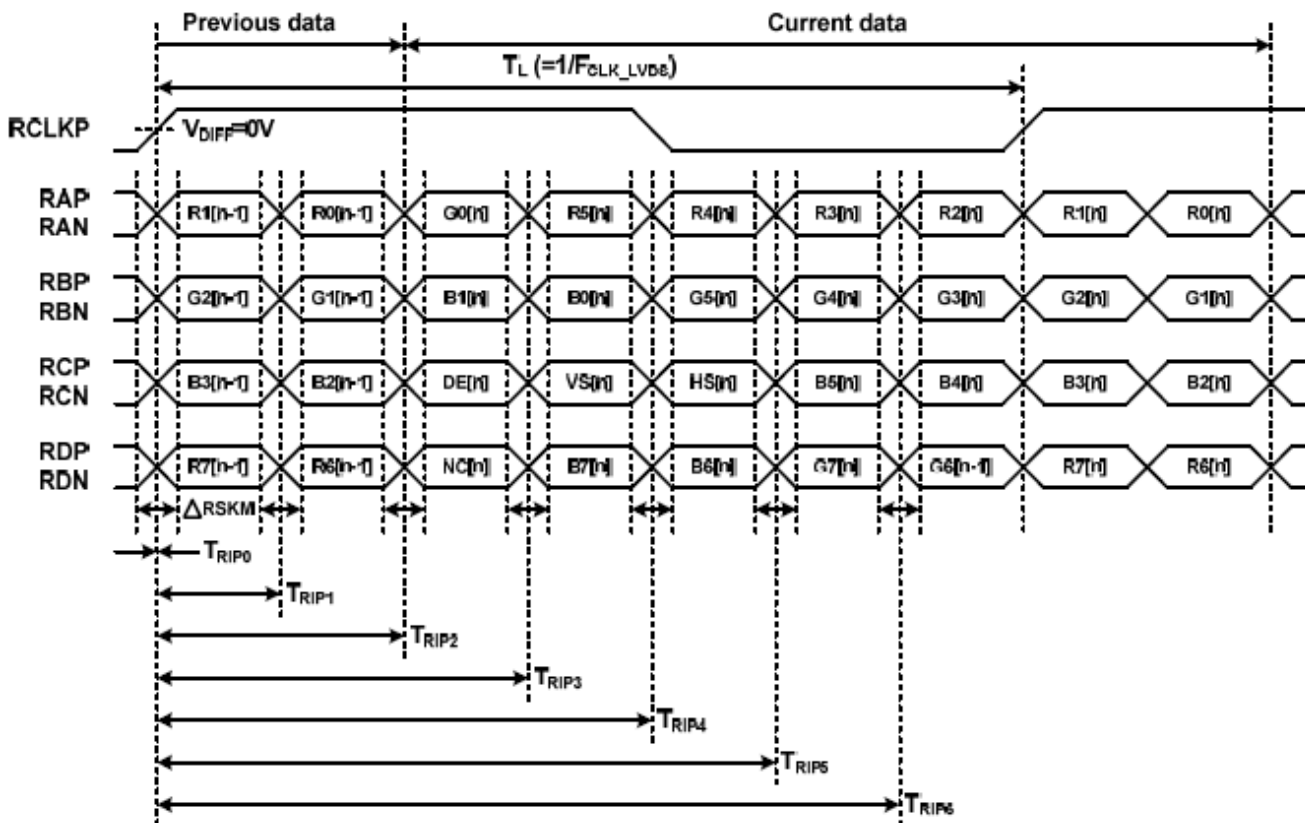

Note (2) LVDS Input Skew Margin

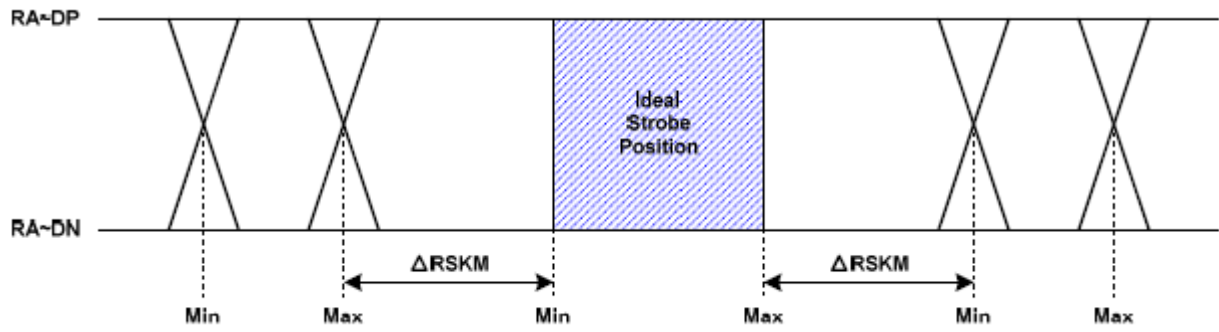

6.2.3 LVDS Inputs

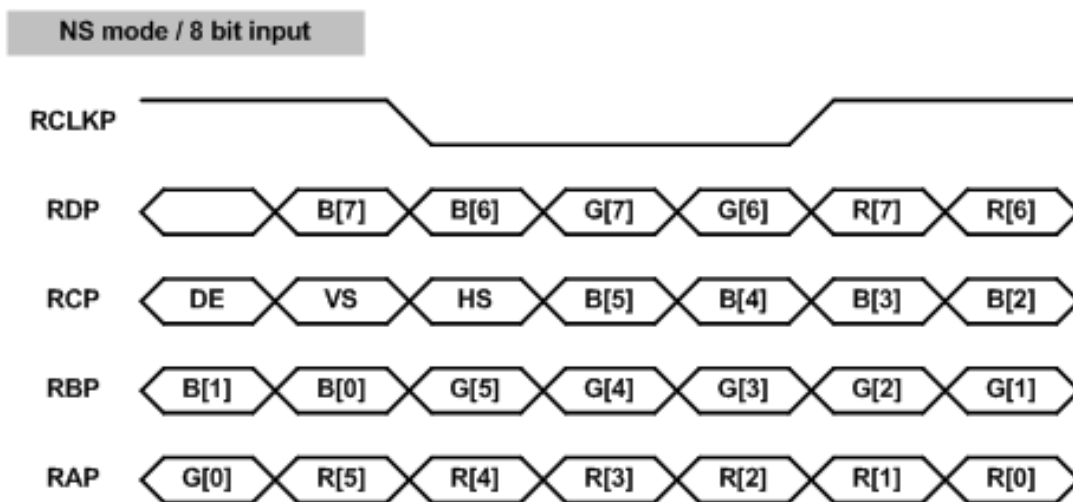

6.3 Interface Timing (DE Only Mode)

SIGNAL	ITEM	SYMBOL	MIN.	TYP.	MAX.	UNIT	NOTE
Frame Frequency	Cycle	f_V		60		Hz	
		T_V		816		lines	(1)
Vertical Active Display Term	Display Period	T_{VD}	-	800	-	lines	
	Vertical Blank Period	T_{VB}	-	16	-	lines	(1)
One Line Scanning Time	Cycle	T_H		1408		clocks	(1)
Horizontal Active Display Term	Display Period	T_{HD}	-	1280	-	clocks	(1)
		T_{HB}	-	128	-	pixels	
Main CLK Freq.	Cycle	$1/T_C$	-	68.94		MHz	

Note (1) $T_V \times T_H \times f_V$ 의 값이 Main CLK Freq.의 Max 값을 넘지 말것

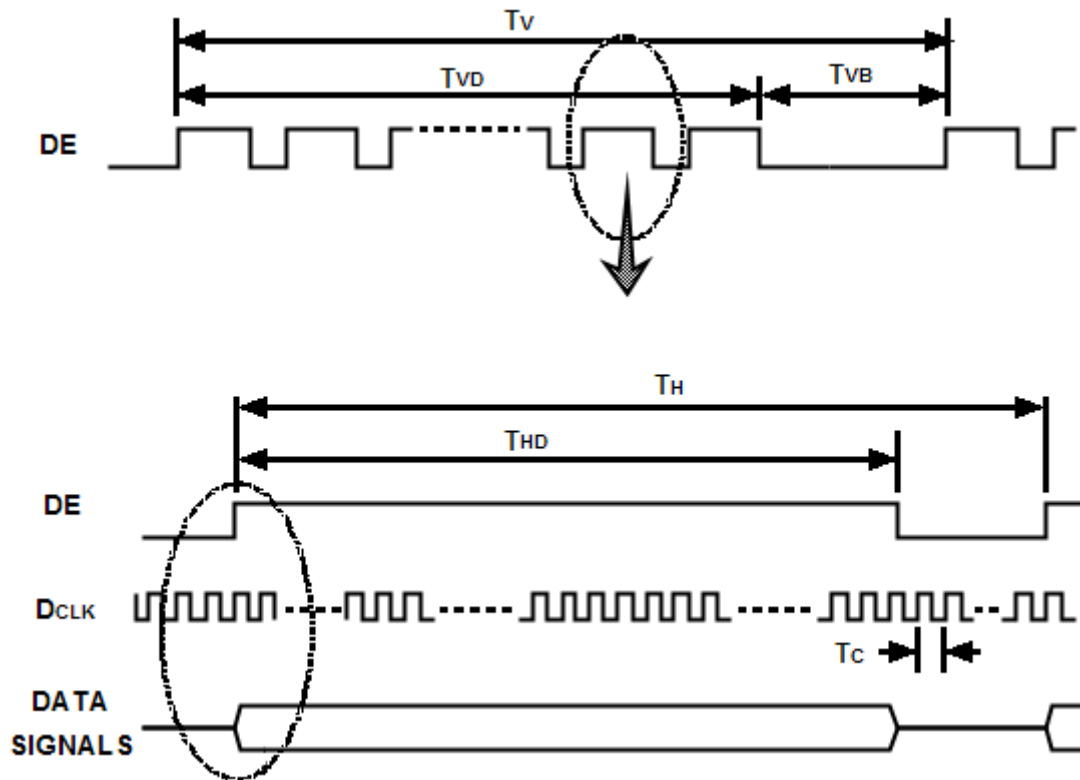

6.4 입력신호와 표시색상과의 관계

COLOR	DISPLAY	DATA SIGNAL																												GRAY SCALE LEVEL
		RED							GREEN							BLUE														
		R0	R1	R2	R3	R4	R5	R6	R7	G0	G1	G2	G3	G4	G5	G6	G7	B0	B1	B2	B3	B4	B5	B6	B7					
BASIC COLOR	BLACK	0	0	0	0	0	0	0	0	0	0	0	0	0	0	0	0	0	0	0	0	0	0	0	0	0	0	0	-	
	BLUE	0	0	0	0	0	0	0	0	0	0	0	0	0	0	0	0	1	1	1	1	1	1	1	1	1	1	1	-	
	GREEN	0	0	0	0	0	0	0	0	1	1	1	1	1	1	1	1	0	0	0	0	0	0	0	0	0	0	0	-	
	CYAN	0	0	0	0	0	0	0	0	1	1	1	1	1	1	1	1	1	1	1	1	1	1	1	1	1	1	1	-	
	RED	1	1	1	1	1	1	1	1	0	0	0	0	0	0	0	0	0	0	0	0	0	0	0	0	0	0	0	-	
	MAGENTA	1	1	1	1	1	1	1	1	0	0	0	0	0	0	0	0	1	1	1	1	1	1	1	1	1	1	1	-	
	YELLOW	1	1	1	1	1	1	1	1	1	1	1	1	1	1	1	1	0	0	0	0	0	0	0	0	0	0	0	-	
	WHITE	1	1	1	1	1	1	1	1	1	1	1	1	1	1	1	1	1	1	1	1	1	1	1	1	1	1	1	-	
GRAY SCALE OF RED	BLACK	0	0	0	0	0	0	0	0	0	0	0	0	0	0	0	0	0	0	0	0	0	0	0	0	0	0	R0		
	DARK ↑	1	0	0	0	0	0	0	0	0	0	0	0	0	0	0	0	0	0	0	0	0	0	0	0	0	0	R1		
		0	1	0	0	0	0	0	0	0	0	0	0	0	0	0	0	0	0	0	0	0	0	0	0	0	0	R2		
		:	:	:	:	:	:	:	:	:	:	:	:	:	:	:	:	:	:	:	:	:	:	:	:	:	:	R3~R252		
	:	:	:	:	:	:	:	:	:	:	:	:	:	:	:	:	:	:	:	:	:	:	:	:	:	:				
	↓ LIGHT	1	0	1	1	1	1	1	1	0	0	0	0	0	0	0	0	0	0	0	0	0	0	0	0	0	0	R253		
		0	1	1	1	1	1	1	1	0	0	0	0	0	0	0	0	0	0	0	0	0	0	0	0	0	0	R254		
	RED	1	1	1	1	1	1	1	1	0	0	0	0	0	0	0	0	0	0	0	0	0	0	0	0	0	0	R255		
GRAY SCALE OF GREEN	BLACK	0	0	0	0	0	0	0	0	0	0	0	0	0	0	0	0	0	0	0	0	0	0	0	0	0	0	G0		
	DARK ↑	0	0	0	0	0	0	0	0	1	0	0	0	0	0	0	0	0	0	0	0	0	0	0	0	0	0	G1		
		0	0	0	0	0	0	0	0	0	1	0	0	0	0	0	0	0	0	0	0	0	0	0	0	0	0	G2		
		:	:	:	:	:	:	:	:	:	:	:	:	:	:	:	:	:	:	:	:	:	:	:	:	:	:	G3~G252		
	:	:	:	:	:	:	:	:	:	:	:	:	:	:	:	:	:	:	:	:	:	:	:	:	:	:				
	↓ LIGHT	0	0	0	0	0	0	0	0	1	0	1	1	1	1	1	1	0	0	0	0	0	0	0	0	0	0	G253		
		0	0	0	0	0	0	0	0	0	1	1	1	1	1	1	1	0	0	0	0	0	0	0	0	0	0	G254		
	GREEN	0	0	0	0	0	0	0	0	1	1	1	1	1	1	1	1	0	0	0	0	0	0	0	0	0	0	G255		
GRAY SCALE OF BLUE	BLACK	0	0	0	0	0	0	0	0	0	0	0	0	0	0	0	0	0	0	0	0	0	0	0	0	0	0	B0		
	DARK ↑	0	0	0	0	0	0	0	0	0	0	0	0	0	0	0	0	1	0	0	0	0	0	0	0	0	0	B1		
		0	0	0	0	0	0	0	0	0	0	0	0	0	0	0	0	0	1	0	0	0	0	0	0	0	0	B2		
		:	:	:	:	:	:	:	:	:	:	:	:	:	:	:	:	:	:	:	:	:	:	:	:	:	:	B3~B252		
	:	:	:	:	:	:	:	:	:	:	:	:	:	:	:	:	:	:	:	:	:	:	:	:	:	:				
	↓ LIGHT	0	0	0	0	0	0	0	0	0	0	0	0	0	0	0	0	1	0	1	1	1	1	1	1	1	1	B253		
		0	0	0	0	0	0	0	0	0	0	0	0	0	0	0	0	0	1	1	1	1	1	1	1	1	1	B254		
	BLUE	0	0	0	0	0	0	0	0	0	0	0	0	0	0	0	0	1	1	1	1	1	1	1	1	1	1	B255		

입력신호 : 0=Low level voltage, 1=High level voltage
 NOTE : MSB는 R7,G7,B7이고 LSB는 R0,G0,B0

6.5 PANEL상의 화소 표시위치

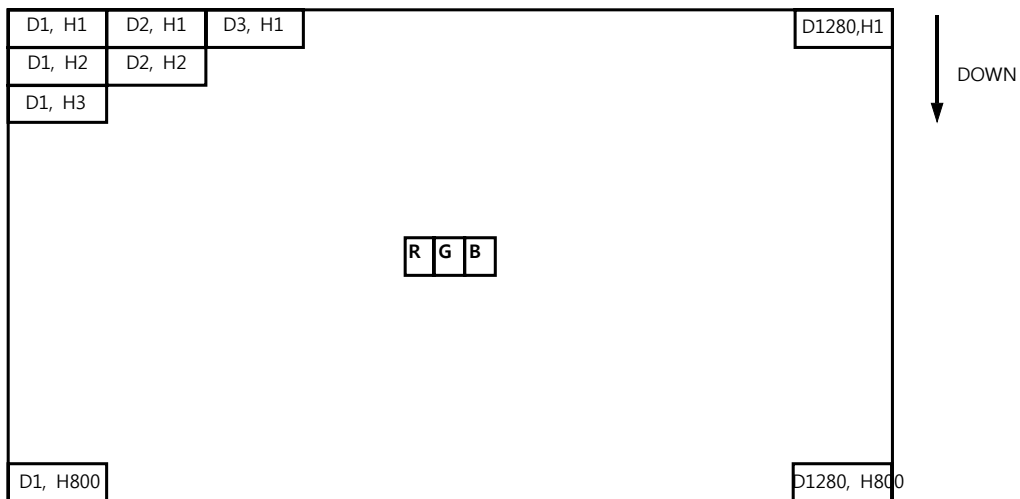

NOTE : (Dn, Hm) = 오른쪽으로 n번째, 아래로 m 번째 화소

6.6 Power sequence

: Latch-up이나 LCD 모듈의 DC operation을 막기 위해 전원 온/오프 순서는 아래와 같아야 함

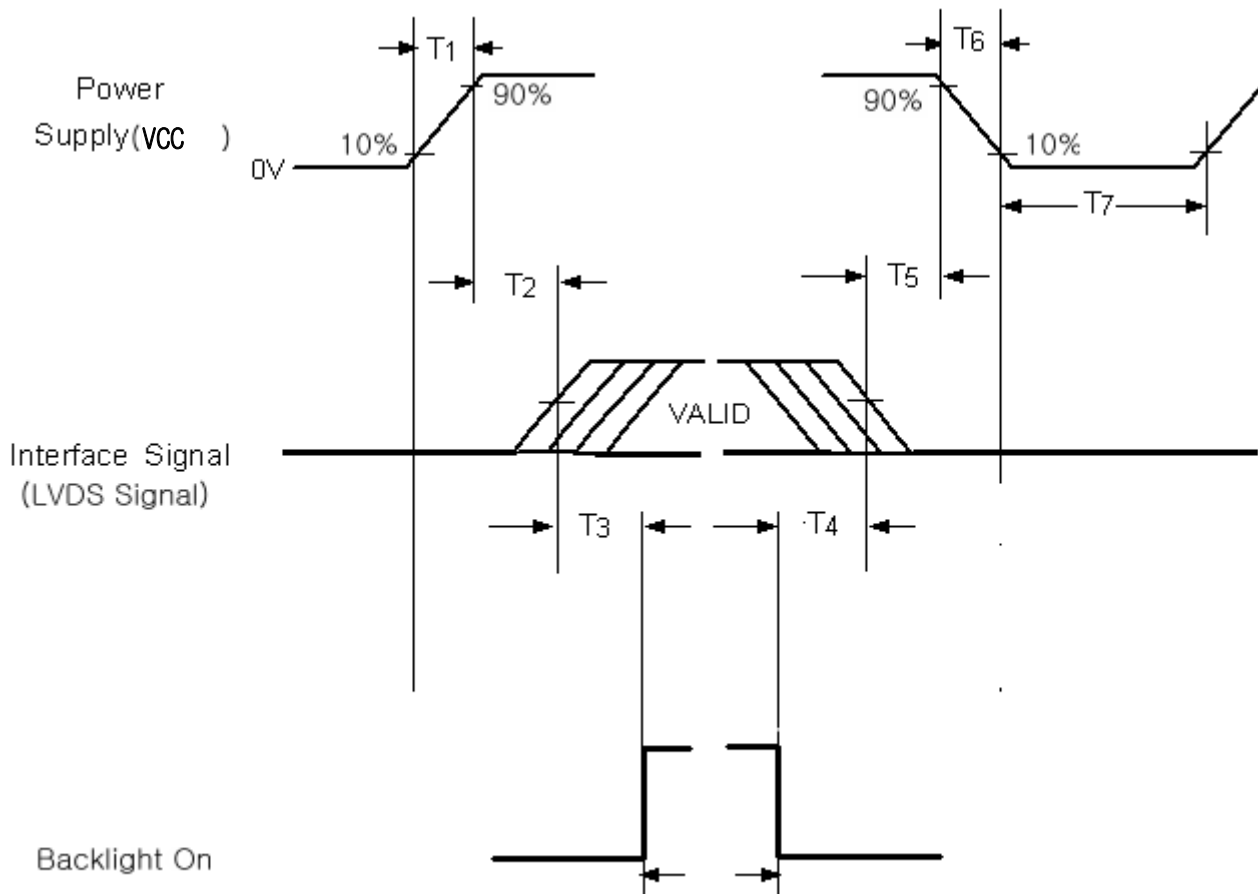

Item	Spec
T1	$0.5 \leq T1 \leq 10\text{msec}$
T2	$0 \leq T2 \leq 50\text{msec}$
T3	$T3 \geq 300\text{msec}$
T4	$T4 \geq 200\text{msec}$
T5	$0 \leq T5 \leq 50\text{msec}$
T6	$0 \leq T6 \leq 10\text{msec}$
T7	$T7 \geq 500\text{msec}$

NOTE

- (1) 모듈에 신호를 인가하는 외부장치의 전원은 Vcc와 같아야 한다.
- (2) LCD 동작 범위내에서 램프의 전압을 인가 할 것. LCD가 동작되기 전에 램프를 켜거나 램프를 끄기 전에 LCD를 끌 때, 화면이 순간적으로 백색상태가 됨.
- (3) Vcc가 인가된 후 인터페이스 신호가 들어가지 않는 상태(Interface Signal High Impedance)로 장시간 두지 말 것.
- (4) Power Off후 재 Power On하기 전에 제품이 완전히 방전 후 측정.

7. 광학적 특성

광특성은 Note (5)의 방법으로 암실에서 측정한다.

측정조건: Ta= 25±2°C, VCC=3.3V, fV=60Hz, fDCLK=68.94MHz, ILED = 23mA

※ 측정 Board 용 current 는 23mA 이나, PWM 으로 조절하여 21mA 로 측정

ITEM		SYMBOL	CONDITI ON	MIN.	TYP.	MAX.	UNIT	NOTE
Contrast Ratio(Center)		CR	φ=0 θ=0 Viewing Normal Angle	720	-	-		(2)의 ①
Response time at 25°C	Rising	TR + TF		-	30	45	ms	(3), (5)
	Falling							
Luminance of White(Center)		YL,AVG		320	400	-	cd/m ²	(2)의 ②
Cross Modulation		DSHA		-	-	2.0	%	(4)
색재현성		-		45	50	-	%	NTSC
색온도		T		6000	7000	8000	K	(2)의 ④
Gray scale linearity	Normal	Δu'v'		-	-	0.05	-	(2)의 ⑤
	DMB	Δu'v'		-	-	0.02	-	
Gamma		-		1.9	2.2	2.5	-	(2)의 ⑥
Δuv		-	0.00	0.01	0.02	-	(2)의 ⑦	
Color Chromaticity (CIE 1931)	Red	RX	TYP -0.03	TYP +0.03	0.601		CA-210 측정	
		RY			0.347			
	Green	GX			0.322			
		GY			0.580			
	Blue	BX			0.147			
		BY			0.126			
	White	WX			0.295			
		WY			0.327			
Viewing Angle	Hor.	θL	CR≥10	Degrees	-	80	-	(1),(5)
		θR			-	80	-	
	Ver.	φH			-	80	-	
		φL			-	80	-	
Uniformity (9 points)		ΔW		80%	-			(2)의 ③

NOTE (1)

시야각(Viewing angle)의 정의 : C/R이 10이상되는 시각의 범위

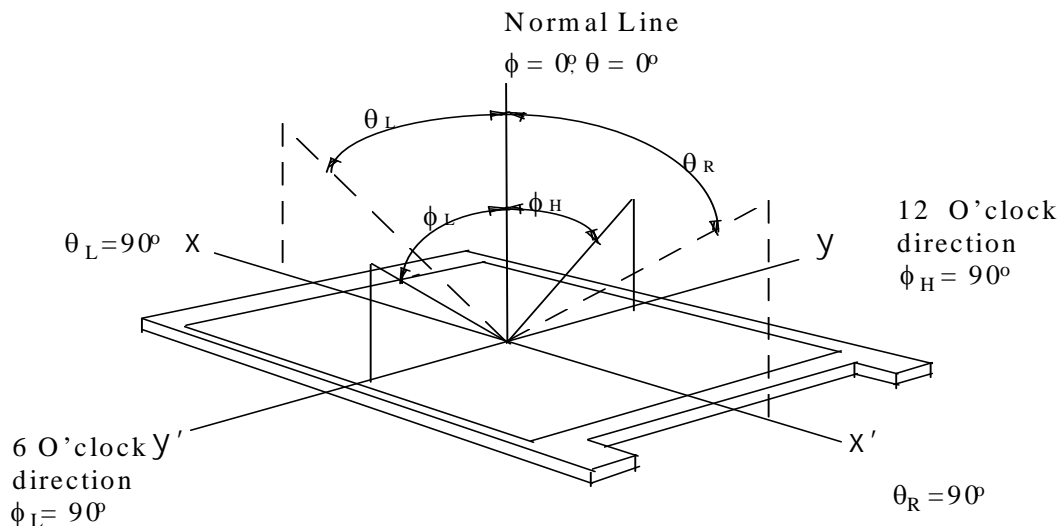

NOTE (2)

측정위치 : 패널상 측정위치는 9개 점으로 한다.

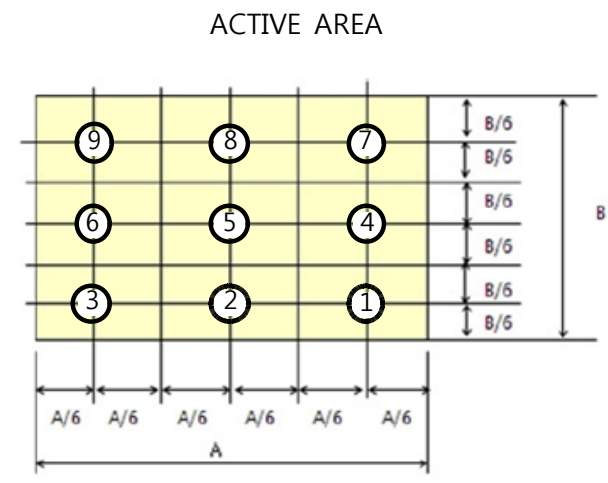

Fig. 1 (A,B : Active area)

○ : test point

① 대비비(C/R : Contrast ratio)

: 측정위치 중앙의 1개 점에서 밝은 상태(GMAX)와 어두운 상태(GMIN)의 비로 정의.

$$C/R(n) = \frac{\text{Panel 상 위치 } n\text{에서 밝은 상태 휘도}}{\text{Panel 상 위치 } n\text{에서 어두운 상태 휘도}}$$

여기서, n은 패널 중앙 측정위치임.

② White 휘도의 정의 (YL,AVG) :

: 측정위치는 패널 중앙에서 white 휘도를 측정한 값
 : ILED = 23mA 일때의 휘도 측정 값

③ Uniformity 9 point(δw) 측정

: 패널상의 9개의 test points를 측정하여 아래식과 같이 정의(①~⑨).

$$dW = \frac{\text{9개 측정값중 최소값}}{\text{9개 측정값중 최대값}}$$

④ 색온도 측정

: 패널 중앙 CA-210으로 측정

⑤ Gray scale linearity 측정

: CA-210으로 패널 중앙에서 u' , v' 측정

$$\Delta u'v' = (\Delta u'^2 + \Delta v'^2)^{0.5}$$

$$\Delta u' = \text{Max } u' - \text{Min } u'$$

$$\Delta v' = \text{Max } v' - \text{Min } v'$$

⑥ Gamma 측정

: CA-210으로 패널 중앙에 놓고 Gray별 휘도 측정 및 Graph 로 나타냄

: Gamma Graph(1.95, 2.2, 2.45)와 동시 비교 하여 Gamma 수치 비교

⑦ Δuv

: CA-210으로 패널 중앙에서 Δuv 측정

NOTE (3)

응답시간(Response time)의 정의

: 화면이 어두워 질 때와 밝아질 때에 투과율이 10%와 90%사이로 변화하는 시간의 합.(BM-7 측정, 거리 50cm)

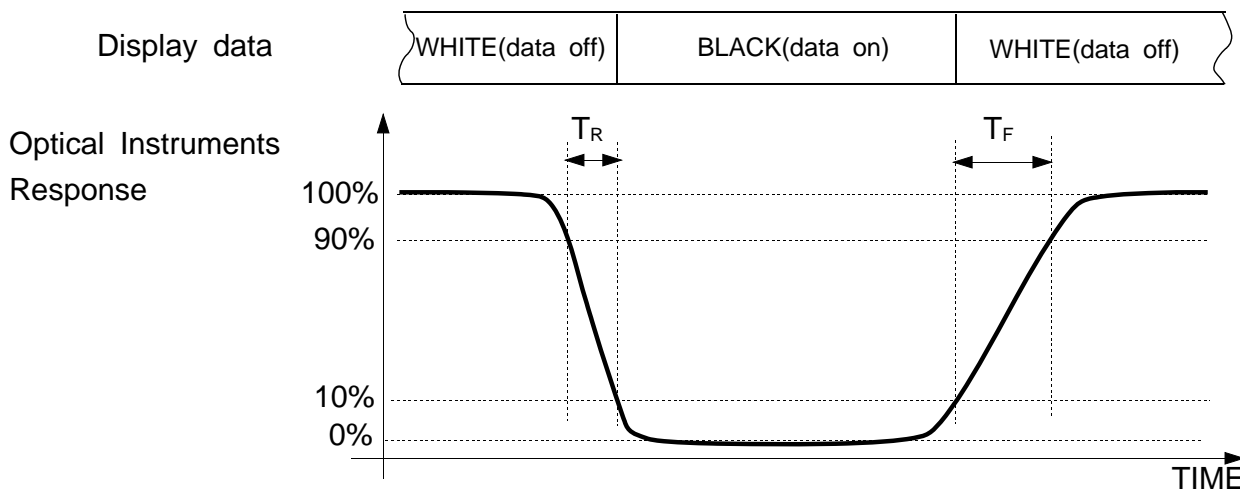

NOTE (4)

상호 혼선(Crosstalk; Cross modulation)의 정의(D_{SHA}): 화소간의 신호간섭에 의하여 대비비가 저하되는 현상.

Crosstalk 계산 방법

$$\text{Crosstalk Modulation Ratio}(D_{SHA}) = \frac{|Y_A - Y_B|}{Y_A} \times 100 (\%)$$

Where

Y_A, Y_B = 측정은 2°Viewing Angle (측정 area ψ12mm)

Black Bar 이외의 back ground pattern은 Gray 1~63 범위를 포함.

㉠ Horizontal-Crosstalk 측정방법

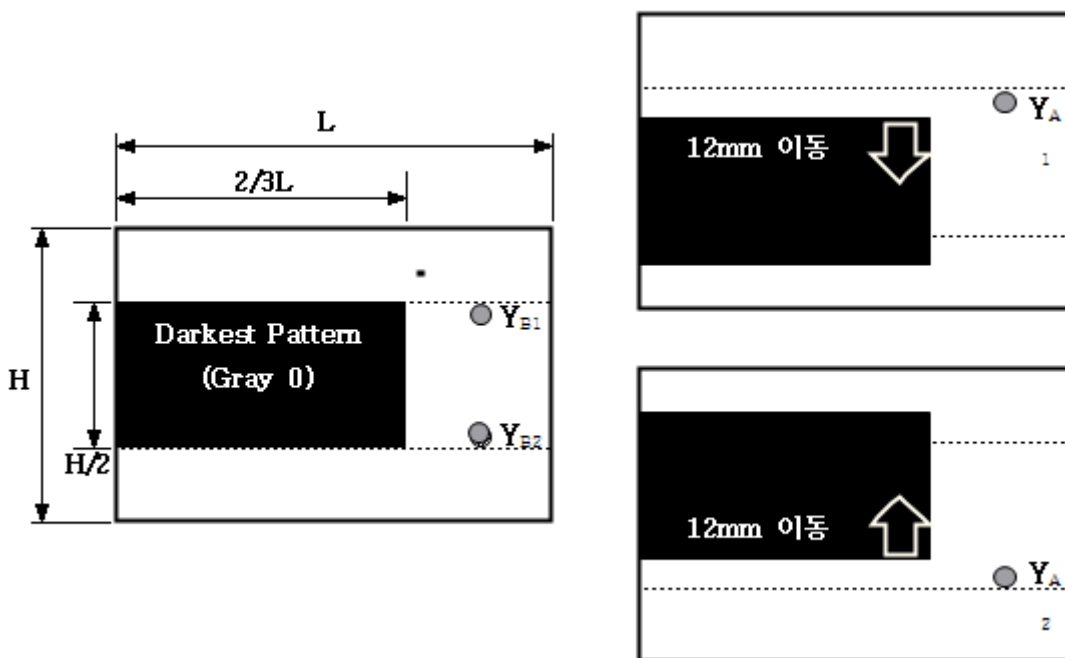

㉢ Vertical-Crosstalk 측정방법

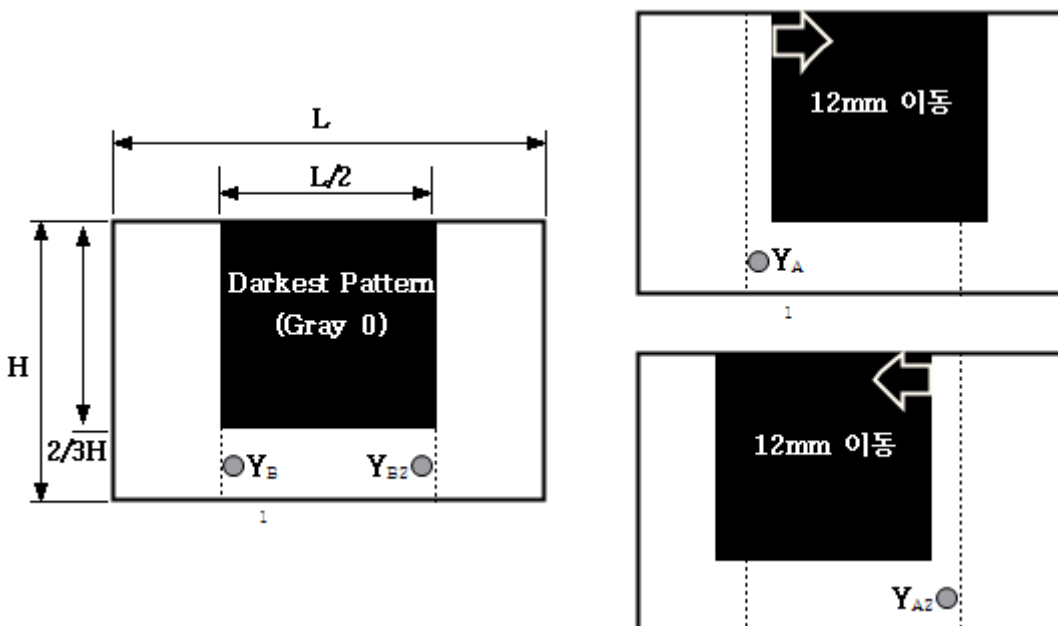

NOTE (5)

상온에서 30분 방치 후 정격에서 백라이트를 켜고 30분 후에 측정.

Photodetector : BM-5A ($d = 40\text{cm}$), PR-650 ($d = 50\text{cm}$)

환경조건: 주위 온도 : $25^{\circ}\text{C} \pm 2^{\circ}\text{C}$

암실, 무풍(직접적인 바람제거), 무진동

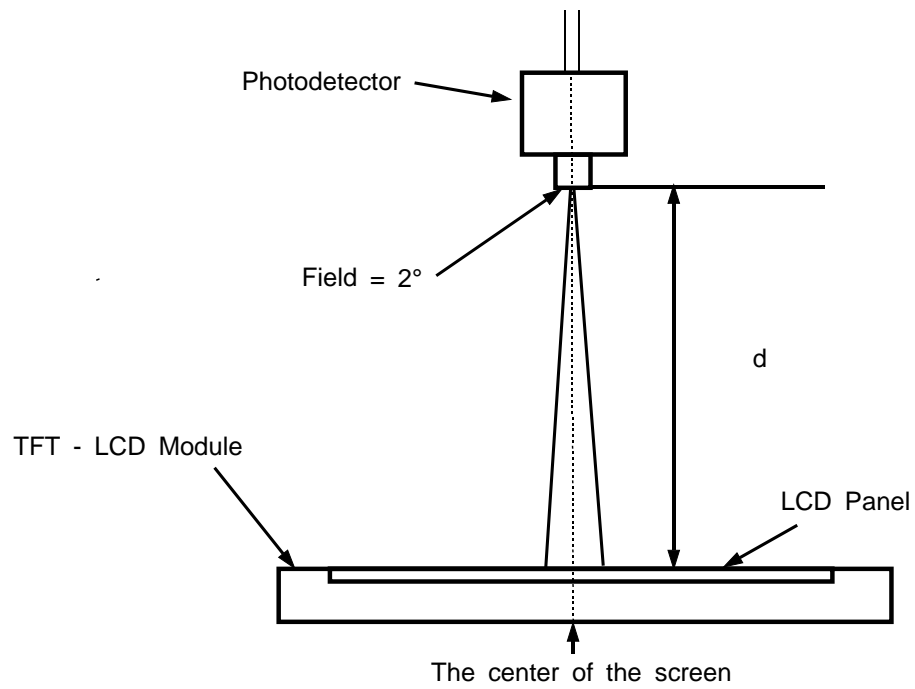

8. 기구적 특성

8-1 Module Size

항 목		MIN.	TYP.	MAX.	UNIT	비 고
OUTLINE	가로	227.91	228.21	228.51	mm	(1),(2)
	세로	148.56	148.86	149.16	mm	(1),(2)
두께		2.09	2.39	2.69	mm	(1),(2)
무게		120	130	140	g	(2)

NOTE 1) Outline Dimension 참조

- * Outline Dimension의 측정 조건 : 버니어 캘리퍼스를 이용
- 측정력:300g
- * W/O POL(上) 보호막(0.06mm)
- * 기타 Dimension 도면 참조.

NOTE 2) W/O Tape Thickness

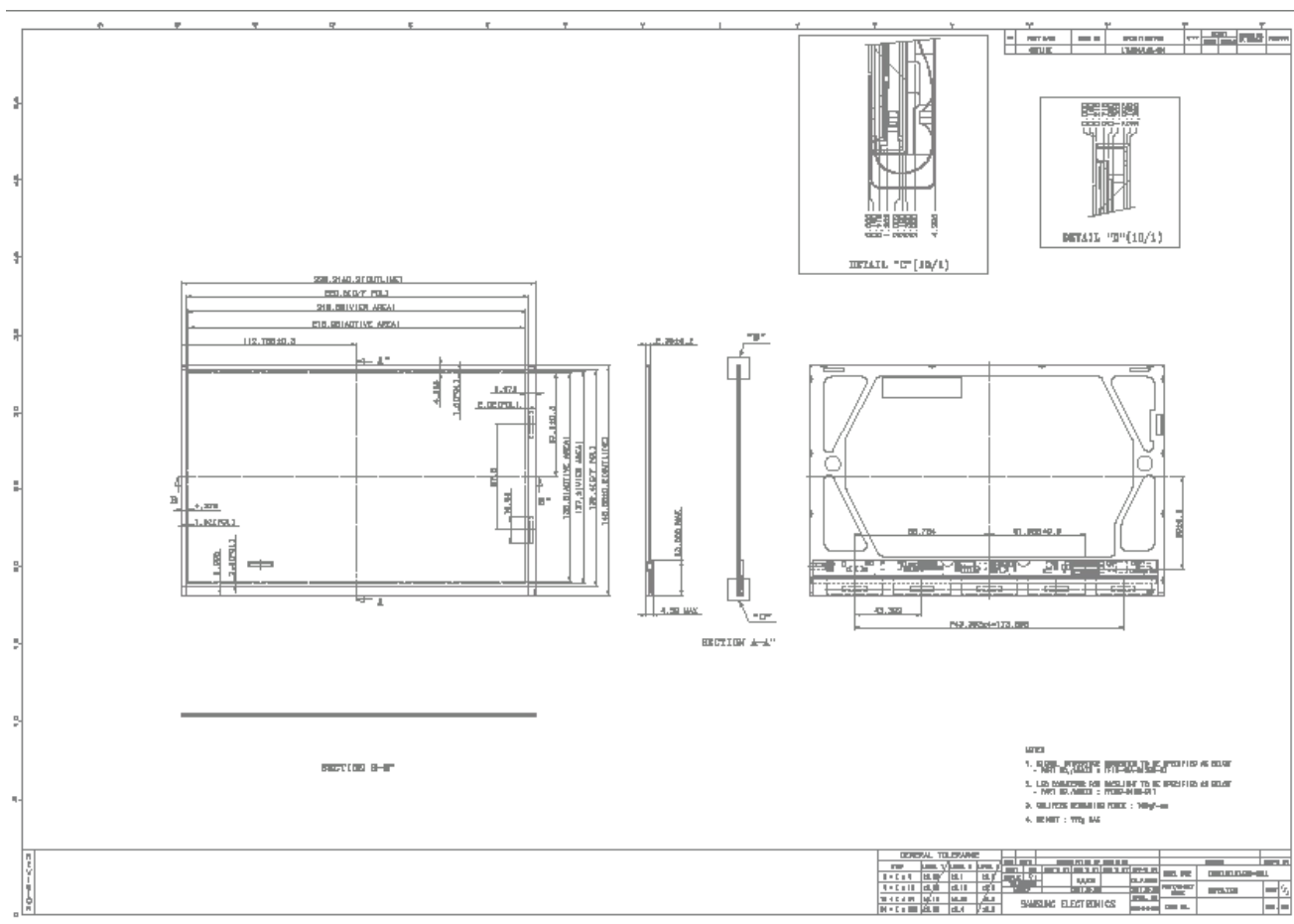

9. Label 및 포장 사양

9.1 Label 사양 (ES4~)

A nameplate bearing followed by is affixed to a shipped product at the specified location on each product.

R	A	10	07	12	1	0
①	②	③	④	⑤	⑥	⑦

① Module Site

→ R (Radiant), D (DID)

② Production Shift (A: Day, B: Swing, C: GY)

③ Year : 10(2010), 11(2011)

④ Month : 01(January), 02(February), 03(March)...

⑤ Day : 1~31 일

⑥ Assy 조립 Line : Radiant 기구조립 1~13 Line 표기 (1~D)

⑦ Sample 구분 (0: 양산, 1: 개발)

[제품 라벨]



* 바코드 사양

- ① 고객 라벨 사양
- ② Cell ID

* 라벨 사양

- ③ 고객 라벨 사양
- ④ 특허 번호
- ⑤ 제조국가 (최종단계 제조국가)
- ⑥ UR마크, PR Free마크
- ⑦ Sample 구분 표기
: 개발모델 - 7H / 양산모델 - 무표기
- ⑧ 제품명
- ⑨ Cell ID

[소BOX 라벨]

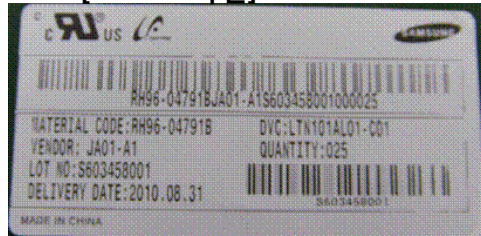

9.2 포장 사양

No	Part name	Quality	관리기준(표면저항)
1	Packing Bag	1Folding	10 [^] 11 이하
2	CUSHION-TRAY	2 modules / 1 tray 21 tray / 1box	10 [^] 11 이하
3	PACKING CASE	1 set	-

※ 기타 PACKING CASE LABEL 에 LEAD FREE Mark 반영 함

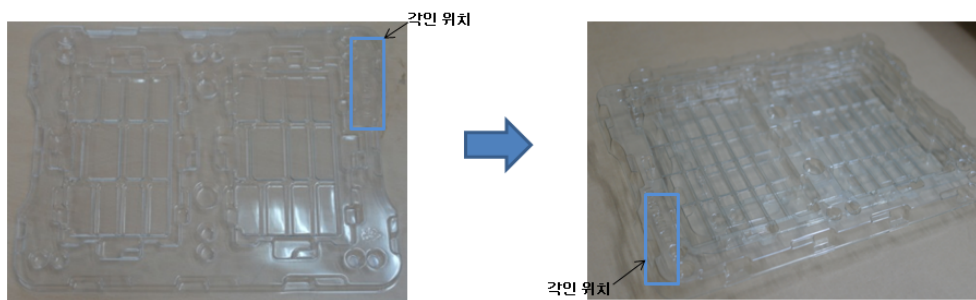
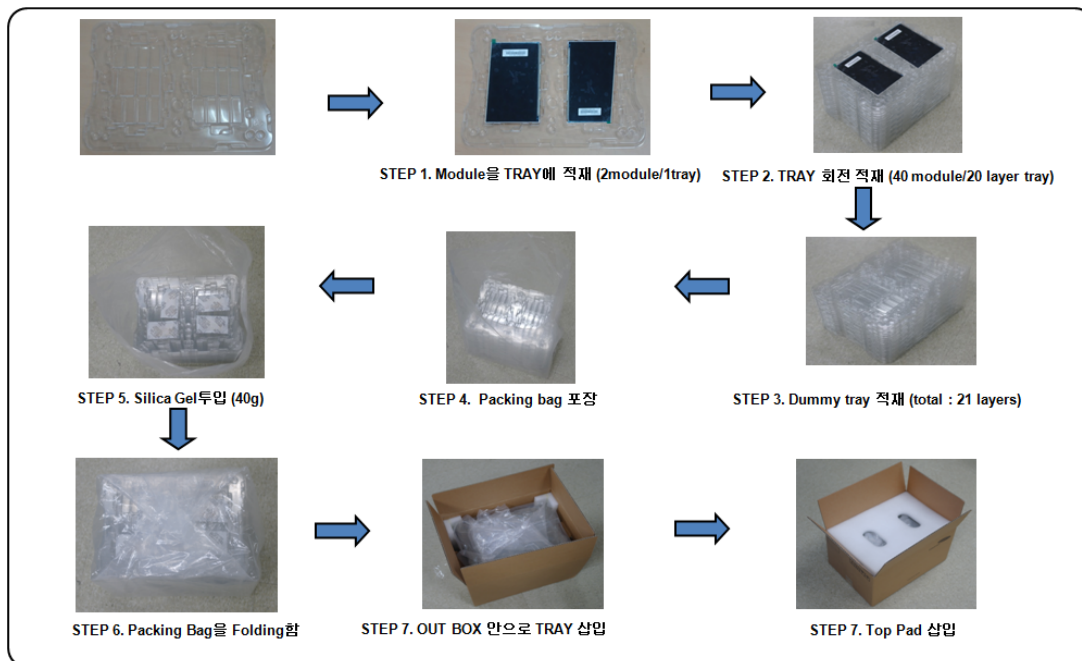
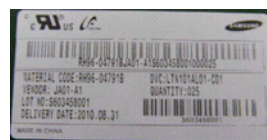

2번째 담은 각인 첫 단 반대 방향으로 올 수 있도록 회전 하여 적재 (매단 적재 시 각인 위치가 맞출리도록 회전하여 적재 함)

NO	품명	비고
1	TFT-LED Modules	40modules / 1box
2	CUSHION-TRAY	2 modules / 1 tray 21 tray / 1box
3	PACKING CASE	12ea /1Pallet
4	PACKING-PALLET BOX	1ea / 1Pallet
5	PALLET-PLASTIC	1ea
6	적재방법	12 Box / 1 Pallet Pallet 2단 적재

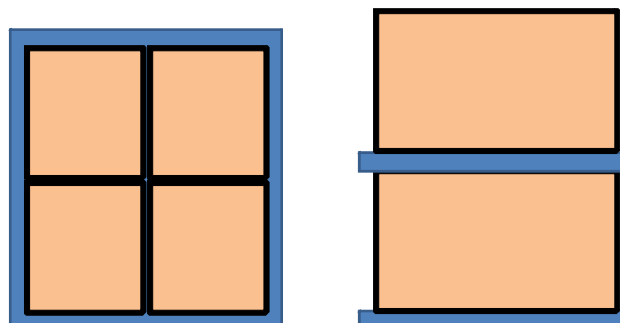

10. GENERAL PRECAUTIONS

1. Handling

- (a) When the module is assembled, it should be attached to the system firmly using every mounting holes. Be careful not to twist and bend the modules.
- (b) Refrain from strong mechanical shock and / or any force to the module. In addition to damage, this may cause improper operation or damage to the module and LED back-light.
- (c) Note that polarizers are very fragile and could be easily damaged. Do not press or scratch the surface harder than a HB pencil lead.
- (d) Wipe off water droplets or oil immediately. If you leave the droplets for a long time, staining and discoloration may occur.
- (e) If the surface of the polarizer is dirty, clean it using some absorbent cotton or soft cloth.
- (f) The desirable cleaners are water, IPA(Isopropyl Alcohol) or Hexane. Do not use Ketone type materials(ex. Acetone), Ethyl alcohol, Toluene, Ethyl acid or Methyl chloride. It might permanent damage to the polarizer due to chemical reaction.
- (g) If the liquid crystal material leaks from the panel, it should be kept away from the eyes or mouth. In case of contact with hands, legs or clothes, it must be washed away thoroughly with soap.
- (h) Protect the module from static, it may cause damage to the C-MOS Gate Array IC.
- (i) Use fingerstalls with soft gloves in order to keep display clean during the incoming inspection and assembly process.
- (j) Do not disassemble the module.
- (k) Do not pull or fold the lamp wire.
- (l) Do not adjust the variable resistor which is located on the back side.
- (m) Protection film for polarizer on the module shall be slowly peeled off just before use so that the electrostatic charge can be minimized.
- (n) Pins of I/F connector shall not be touched directly with bare hands.

2. STORAGE

- (a) Do not leave the module in high temperature, and high humidity for a long time. It is highly recommended to store the module with temperature from 5 to 40 °C and relative humidity of less than 70%.
- (b) Do not store the TFT-LCD module in direct sunlight.
- (c) The module shall be stored in a dark place. It is prohibited to apply sunlight or fluorescent light during the store.
- (d) Storage period is recommended not to exceed 1 year.

3. OPERATION

- (a) Do not connect, disconnect the module in the " Power On " condition.
- (b) Power supply should always be turned on / off by following item 6.3 " Power on / off sequence ".
- (c) Module has high frequency circuits. Sufficient suppression to the electromagnetic interference shall be done by system manufacturers. Grounding and shielding methods may be important to minimize the interference.
- (d) The FPC cable between the LED chips and its converter power supply shall be a minimized length and be connected directly. The longer cable between the back-light and the converter may cause lower luminance of light source (LED).
- (e) The standard limited warranty is only applicable when the module is used for general notebook applications. If used for purposes other than as specified, SEC is not to be held reliable for the defective operations. It is strongly recommended to contact SEC to find out fitness for a particular purpose.

4. OTHERS

- (a) Ultra-violet ray filter is necessary for outdoor operation.
- (b) Avoid condensation of water. It may result in improper operation or disconnection of electrode.
- (c) Do not exceed the absolute maximum rating value. (the supply voltage variation, input voltage variation, variation in part contents and environmental temperature, so on.) Otherwise the module may be damaged.
- (d) If the module displays the same pattern continuously for a long period of time, it can be the situation when the image "sticks" to the screen.
- (e) This module has its circuitry PCB's on the rear side and should be handled carefully in order not to be stressed.