

SAMSUNG

ELECTRONICS

Approval



TO : IT Solution Business.

DATE : May. 4, 2010

SAMSUNG TFT-LCD

MODEL NO. : LTN101NT06-001

NOTE : Extension code [XXX]
→ LTN101NT06[XXX]
Surface type [**Anti-Glare**]

The information described in this SPEC is preliminary and can be changed without prior notice.

A handwritten signature in black ink, appearing to read 'Janseng Sonum'.

APPROVED BY : _____

PREPARED BY : _____

H.S.Oh

Application Engineer part 1, Device Solution (LCD)

SAMSUNG ELECTRONICS CO., LTD.



Samsung Secret

Doc.No.	LTN101NT06	Rev.No	04-A00-G-100504	Page	1 / 32
---------	------------	--------	-----------------	------	--------

CONTENTS

Revision History	----- (3)
General Description	----- (4)
1. Absolute Maximum Ratings	----- (5)
1.1 Absolute Ratings of environment	
1.2 Electrical Absolute Ratings	
2. Optical Characteristics	----- (7)
3. Electrical Characteristics	----- (10)
3.1 TFT LCD Module	
3.2 Backlight Unit	
3.3 LED Driver	
4. Block Diagram	----- (13)
4.1 TFT LCD Module	
4.2 LED Placement Structure	
5. Input Terminal Pin Assignment	----- (14)
5.1 Input Signal & Power	
5.2 LVDS Interface	
5.3 Timing Diagrams of LVDS For Transmitting	
5.4 Input Signals, Basic Display Colors and Gray Scale of Each Color.	
5.5 Pixel format	
6. Interface Timing	----- (20)
6.1 Timing Parameters	
6.2 Timing Diagrams of interface Signal	
6.3 Power ON/OFF Sequence	
7. Outline Dimension	----- (23)
8. Packing	----- (25)
9. Markings & Others	----- (26)
10. General Precautions	----- (28)

Samsung Secret

REVISION HISTORY

Approval

Date	Revision No.	Page	Summary
May.4,2010	A00	All	The approval spec was issued.

Samsung Secret

GENERAL DESCRIPTION

DESCRIPTION

LTN101NT06 is a color active matrix TFT (Thin Film Transistor) liquid crystal display (LCD) that uses amorphous silicon TFT as switching devices. This model is composed of a TFT LCD panel, a driver circuit and a backlight unit. The resolution of a 10.1" contains 1024 x 600 pixels and can display up to 262,144 colors. 6 O'clock direction is the optimum viewing angle.

FEATURES

- High contrast ratio
- WSVGA (1024 x 600 pixels) resolution
- Fast Response
- LED Back Light with embedded LED Driver
- DE (Data enable) only mode
- 3.3V LVDS Interface
- Onboard EEDID chip
- Green product (RoHS compliant)

APPLICATIONS

- Notebook PC
- If the usage of this product is not for PC application, but for others, please contact SEC

GENERAL INFORMATION

Item	Specification	Unit	Note
Display area	222.72(H) x 125.28(V) (10.1" wide diagonal)	mm	
Driver element	a-Si TFT active matrix		
Display colors	262,144		
Number of pixel	1024 x 600	pixel	
Pixel arrangement	RGB vertical stripe		
Pixel pitch	0.2175(H) x 0.2088(V) (TYP.)	mm	
Display Mode	Normally white		
Surface treatment	Haze 25, Hard-Coating 3H		

Samsung Secret

Mechanical Information

Item		Min.	Typ.	Max.	Unit	Note
Module size	Horizontal (H)	234.5	235.0	235.5	mm	
	Vertical (V)	142.5	143.0	143.5	mm	
	Depth (D)	-	5.0	5.2	mm	(1)
Weight		-	-	200	g	

Note (1) Measurement condition of outline dimension
 . Equipment : Bernier Calipers
 . Push Force : 500g · f (minimum)

1. ABSOLUTE MAXIMUM RATINGS

1.1 ENVIRONMENTAL ABSOLUTE RATINGS

Item	Symbol	Min.	Max.	Unit	Note
Storage temperate	TSTG	-20	60	°C	(1)
Operating temperate (Temperature of glass surface)	TOPR	0	50	°C	(1)
Shock (non-operating)	Snop	-	240	G	(2),(4)
Vibration (non-operating)	Vnop	-	2.41	G	(3),(4)

Note (1) Temperature and relative humidity range are shown in the figure below.
 95 % RH Max. ($40\text{ }^{\circ}\text{C} \geq T_a$)
 Maximum wet - bulb temperature at $39\text{ }^{\circ}\text{C}$ or less. ($T_a > 40\text{ }^{\circ}\text{C}$) No condensation

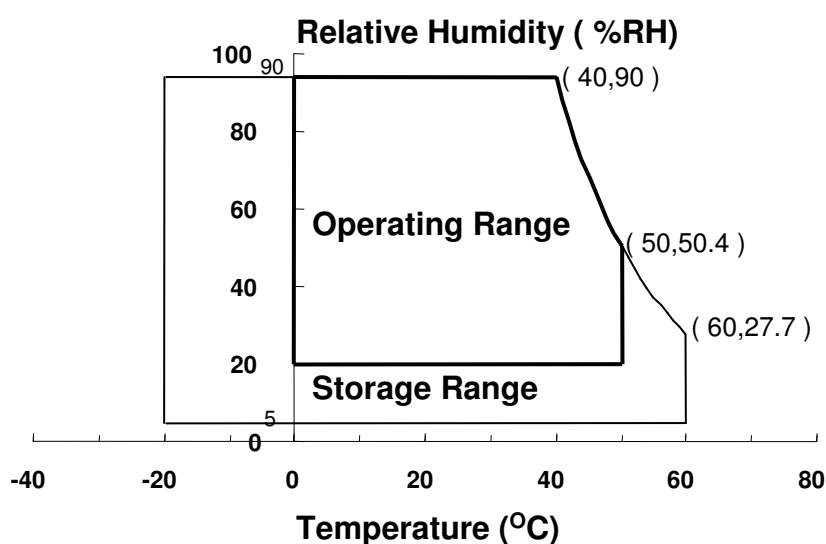

- (2) 2ms, half sine wave, one time for $\pm X$, $\pm Y$, $\pm Z$.
 (3) 5 - 500 Hz, random vibration, 30min for X, Y, Z.
 (4) At testing Vibration and Shock, the fixture in holding the Module to be tested have to be hard and rigid enough so that the Module would not be twisted or bent by the fixture.

Samsung Secret

1.2 ELECTRICAL ABSOLUTE RATINGS

(1) TFT LCD MODULE

 $V_{DD} = 3.3V, V_{SS} = GND = 0V$

Item	Symbol	Min.	Max.	Unit	Note
Power Supply Voltage	V_{DD}	$V_{DD} - 0.3$	$V_{DD} + 0.3$	V	(1)
Logic Input Voltage	V_{IN}	$V_{DD} - 0.3$	$V_{DD} + 0.3$	V	(1)

Note (1) Within T_a ($25 \pm 2 \text{ }^\circ\text{C}$)

(2) BACK-LIGHT UNIT

 $T_a = 25 \pm 2 \text{ }^\circ\text{C}$

Item	Symbol	Min.	Typ.	Max.	Unit	Note
LED Current	I_L	-	25.6	-	mA	(1)
LED Voltage	F_L	-	3.2	-	V	(1)

Note 1) Permanent damage to the device may occur if maximum values are exceeded
 Functional operation should be restricted to the conditions described under normal operating conditions.

Samsung Secret

2. OPTICAL CHARACTERISTICS

The following items are measured under stable conditions. The optical characteristics should be measured in a dark room or equivalent state with the methods shown in Note (5).
Measuring equipment : TOPCON SR-3

* Ta = 25 ± 2 °C, V_{DD}=3.3V, fv= 60Hz, fd_{CLK} = 54.2MHz, IF = 100% duty

Item	Symbol	Condition	Min.	Typ.	Max	Unit	Note	
Contrast Ratio (5 Points)	CR		300	-	-	-	(1), (2), (5)	
Response Time at Ta (Rising + Falling)	T _{RT}		-	16	25	msec	(1), (3)	
Average Luminance of White (5 Points)	Y _{L,AVE}		170	200	-	cd/m ²	IF=100% duty (1), (4)	
Color Chromaticity (CIE)	Red	R _X	Normal Viewing Angle φ = 0 θ = 0	0.523	0.553	0.583	-	(1), (5) SR-3
		R _Y		0.288	0.318	0.348		
	Green	G _X		0.322	0.352	0.382		
		G _Y		0.556	0.586	0.616		
	Blue	B _X		0.135	0.165	0.195		
		B _Y		0.080	0.110	0.140		
	White	W _X		0.283	0.313	0.343		
		W _Y		0.299	0.329	0.359		
Viewing Angle	Hor.	θ _L	CR ≥ 10 At center	40	45	-	Degrees	(1), (5) SR-3
		θ _H		40	45	-		
	Ver.	φ _H		15	20	-		
		φ _L		35	40	-		
Color Gamut	CG		-	45	-	%		
13 Points White Variation	δ _L		-	-	1.7	-	(6)	

Samsung Secret

Note 1) Definition of Viewing Angle : Viewing angle range($10 \leq C/R$)

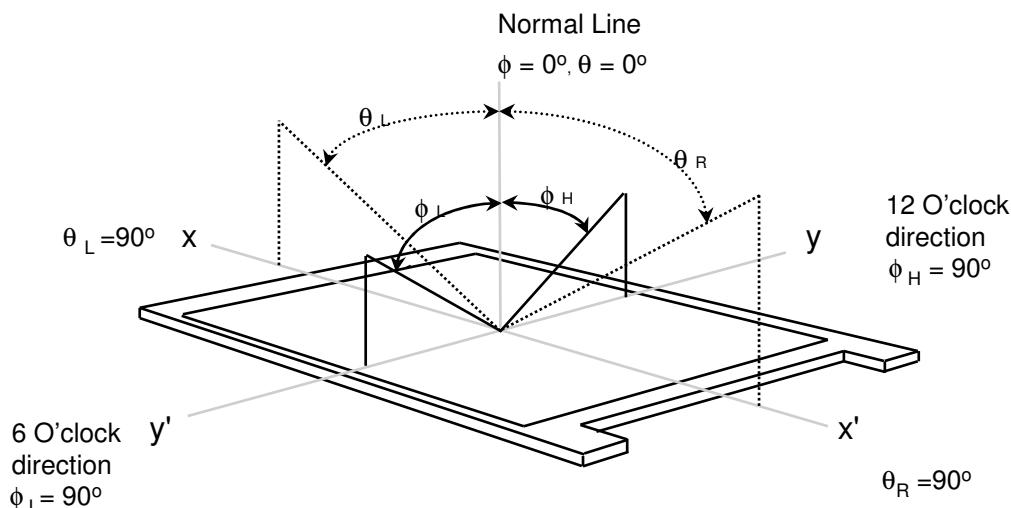

Note 2) Definition of Contrast Ratio (CR) : Ratio of gray max (Gmax) ,gray min (Gmin) at 5 points(4, 5, 7, 9, 10)

$$CR = \frac{CR(4) + CR(5) + CR(7) + CR(9) + CR(10)}{5}$$

Points : (4) , (5) , (7) , (9) , (10) at the figure of Note (6).

Note 3) Definition of Response time :

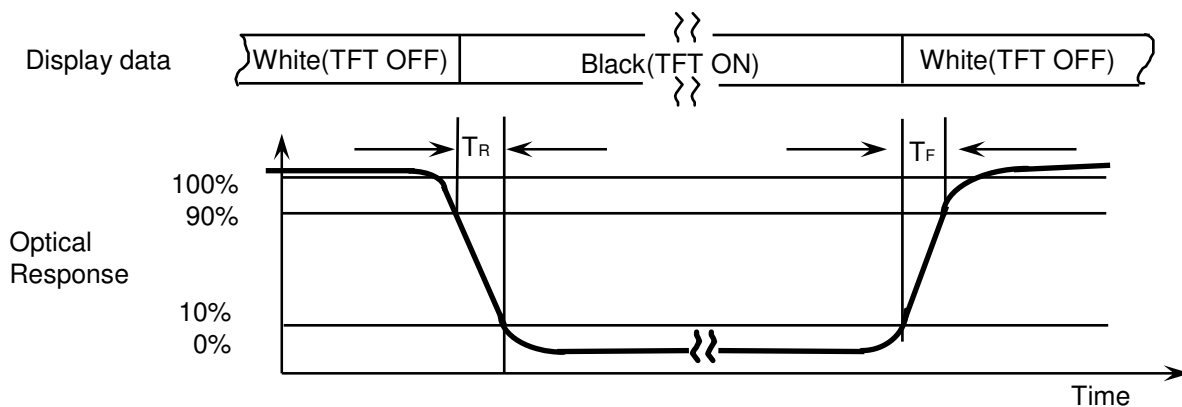

Note 4) Definition of Average Luminance of White : measure the luminance of white at 5 points.

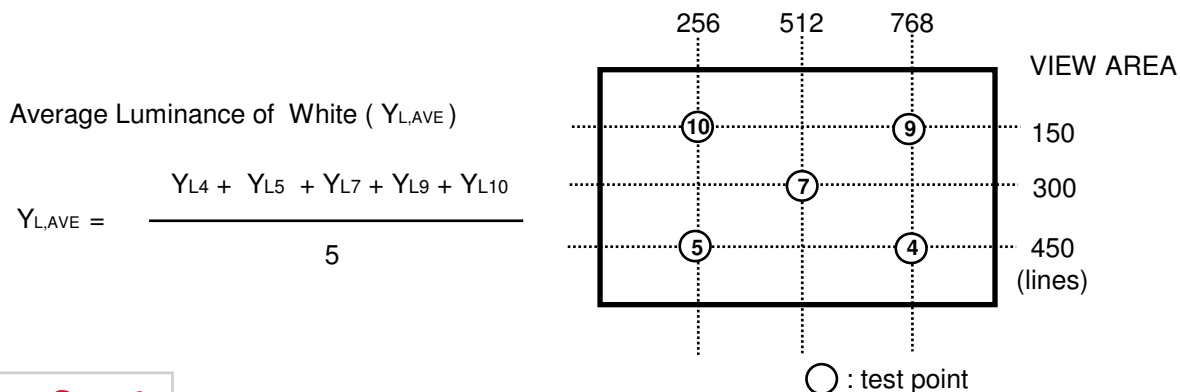

Samsung Secret

Note 5) After stabilizing and leaving the panel alone at a given temperature for 30 min , the measurement should be executed. Measurement should be executed in a stable, windless, and dark room. 30 min after lighting the backlight. This should be measured in the center of screen.
 IF current : 25.6mA
 Environment condition : $T_a = 25 \pm 2 \text{ } ^\circ\text{C}$

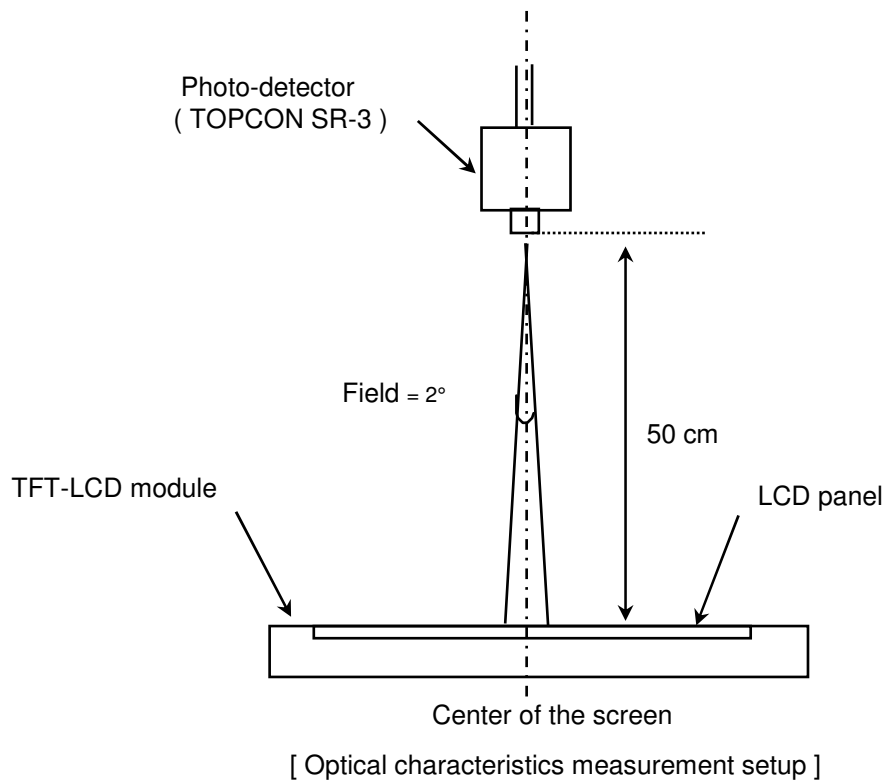

Note 6) Definition of 13 points white variation (δL), CR variation(C_{VER}) [① ~ ⑬]

$$\delta L = \frac{\text{Maximum luminance of 13 points}}{\text{Minimum luminance of 13 points}}$$

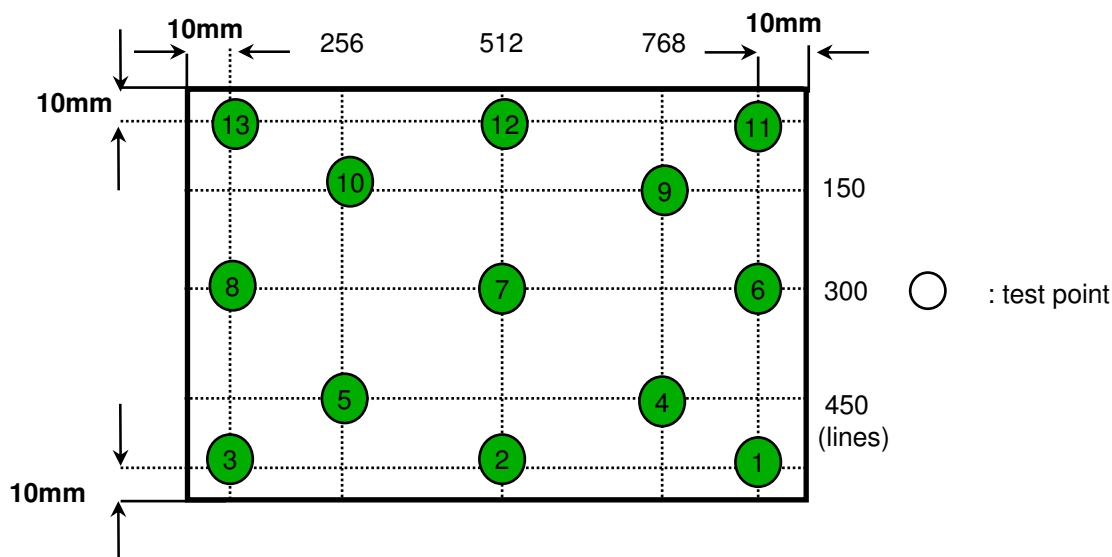

Samsung Secret

3. ELECTRICAL CHARACTERISTICS

3.1 TFT LCD MODULE

 $T_a = 25 \pm 2^\circ\text{C}$

Item	Symbol	Min.	Typ.	Max.	Unit	Note	
Voltage of Power Supply	V_{DD}	3.0	3.3	3.6	V		
Differential Input Voltage for LVDS Receiver Threshold	High	V_{IH}	-	-	+100	mV	$V_{CM} = +1.2V$
	Low	V_{IL}	-100	-	-	mV	
Vsync Frequency	f_V	-	60	-	Hz		
Hsync Frequency	f_H	-	40.38	-	KHz		
Main Frequency	f_{DCLK}	-	54.2	-	MHz	-	
Rush Current	I_{RUSH}	-	-	1.5	A	(4)	
Current of Power Supply	White	I_{DD}	-	175	-	mA	(2),(3)*a
	Mosaic		-	175	-	mA	(2),(3)*b
	V. stripe		-	210	240	mA	(2),(3)*c

Note (1) Display data pins and timing signal pins should be connected. (GND = 0V)

(2) $f_V = 60\text{Hz}$, $f_{DCLK} = 54.2\text{MHz}$, $V_{DD} = 3.3V$, DC Current.

(3) Power dissipation pattern

*a) White Pattern

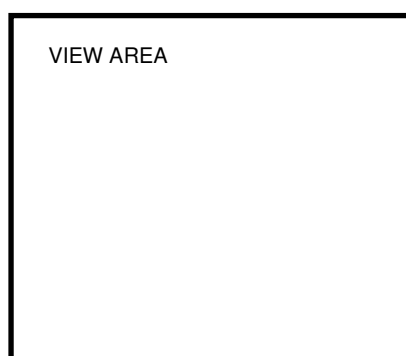

*b) Mosaic Pattern

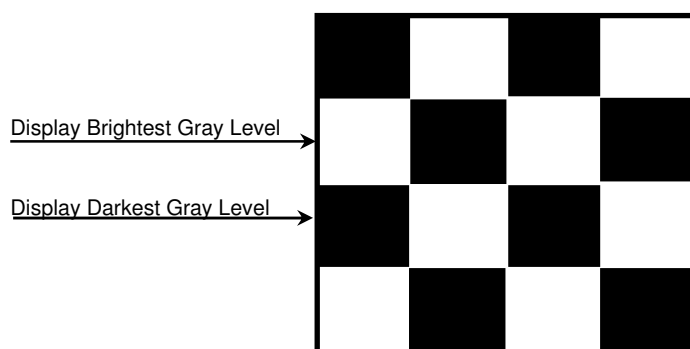

Samsung Secret

*c) 1dot Vertical stripe pattern

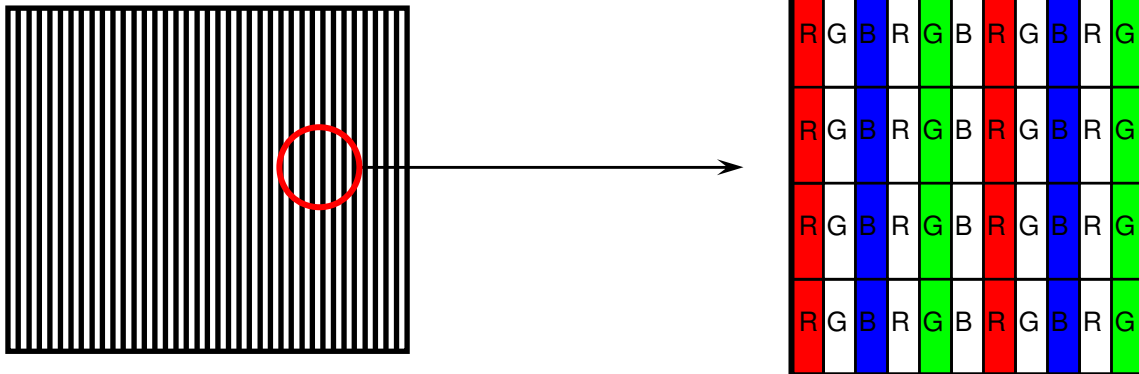

4) Rush current measurement condition

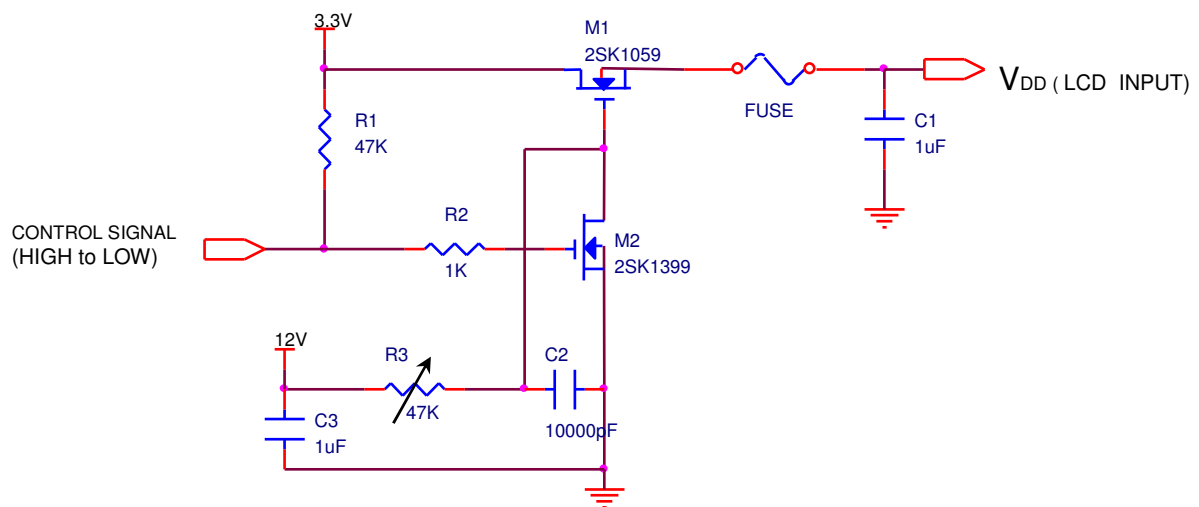

V_{DD} rising time is 470us

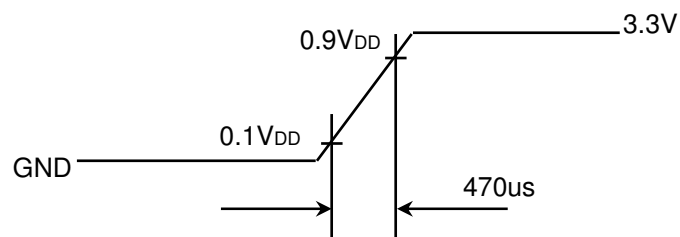

Samsung Secret

3.2 LED Driver

- On board LED Driver (Manufacturer : Richitek)

Ta= 25 ± 2 °C

Item	Symbol	Min.	Typ.	Max.	Unit	Note
Input Voltage	V _{in}	7	12	21	V	
Input Current	I	-	160	-	mA	
EN Control Level	ON	2	3.3	5.0	V	
	OFF	0	0	0.5	V	
PWM Control Level	ON	2	3.3	5.0	V	
	OFF	0	0	0.5	V	
Duty Ratio	D	10	-	100	%	PWM Freq: 1KHz~10KHz
		5	-	100		200Hz~1KHz
External PWM Dimming Control Frequency (BLIM)	F _{BLIM}	-	1	10	kHz	V _{in} =7~20V, BLIM=PWM 0V~3.3V

3.3 LED Driver

Item	Symbol	Min.	Typ.	Max.	Unit	Note
LED Forward Current	I _F	25	25.6	26	mA	
LED Forward Voltage	V _F	3.0	3.2	3.4	V	
LED Array Voltage	V _P	-	19.2	-	V	V _f X 18 LEDs
Power Consumption	P	-	1.9	2.45	W	@200nit, W/ driver

Samsung Secret

4. BLOCK DIAGRAM

4.1 TFT LCD Module

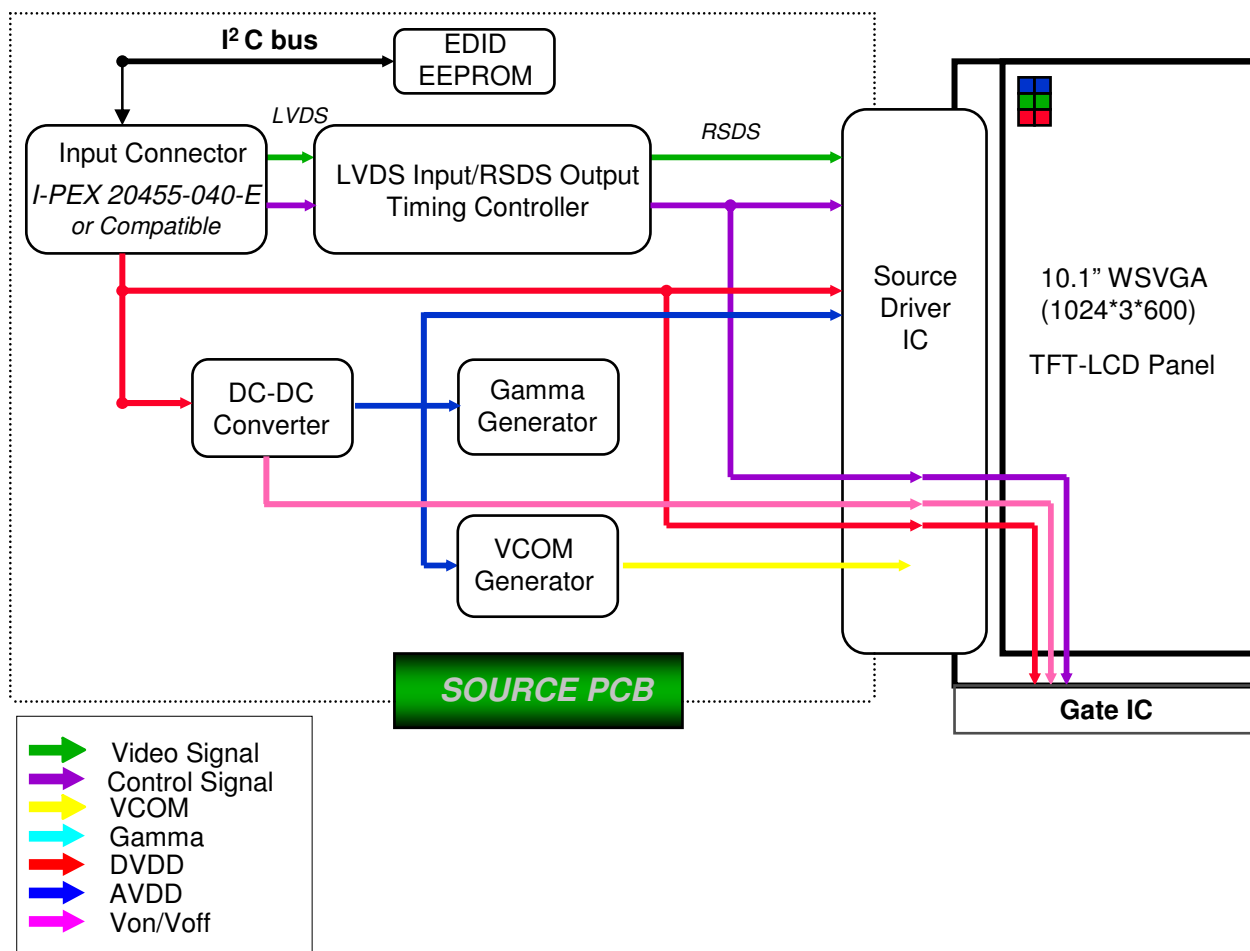

4.2 LED placement structure

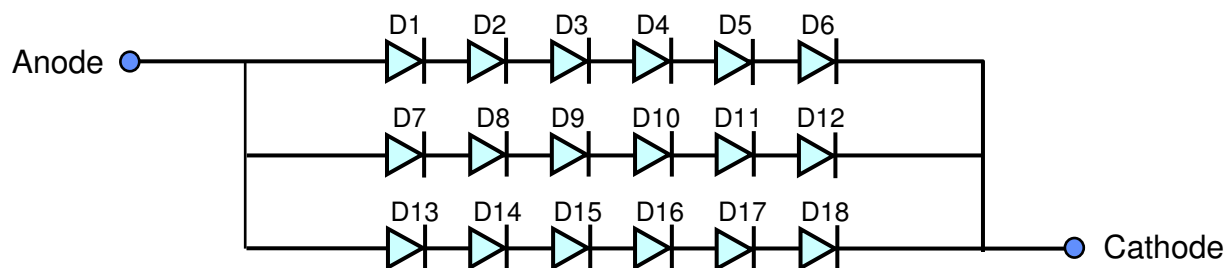

Samsung Secret

5. INPUT TERMINAL PIN ASSIGNMENT

5.1. Input Signal & Power (LVDS, Connector : I-PEX 20455-040E-## or equivalent)

No.	Symbol	Function	Polarity	Remarks
1	NC	No Connect		
2	VDD	Power Supply +3.3V		
3	VDD	Power Supply +3.3V		
4	VEDID	EDID +3.3V Power		
5	NC	No Connect		
6	CLK_EDID	EDID Clock Input		
7	DATA_EDID	EDID Data Input		
8	RxOIN0-	-LVDS Differential Data (Odd R0-R5, G0)	Negative	
9	RxOIN0+	+LVDS Differential Data (Odd R0-R5, G0)	Positive	
10	VSS	Ground		
11	RxOIN1-	-LVDS Differential Data (Odd G1-G5,B0-B1)	Negative	
12	RxOIN1+	+LVDS Differential Data (Odd G1-G5,B0-B1)	Positive	
13	VSS	Ground		
14	RxOIN2-	-LVDS Differential Data (Odd B2-B5,HS,VS,DE)	Negative	
15	RxOIN2+	+LVDS Differential Data (Odd B2-B5,HS,VS,DE)	Positive	
16	VSS	Ground		
17	RxOCKIN-	-LVDS Odd Differential CLK	Negative	
18	RxOCKIN+	+LVDS Odd Differential CLK	Positive	
19	VSS	Ground		
20	NC	No Connect		
21	NC	No Connect		
22	NC	No Connect		
23	NC	No Connect		
24	NC	No Connect		
25	NC	No Connect		
26	NC	No Connect		
27	NC	No Connect		
28	NC	No Connect		
29	NC	No Connect		
30	NC	No Connect		

Samsung Secret

No.	Symbol	Function	Polarity	Remarks
31	VLED_GND	LED Ground		
32	VLED_GND	LED Ground		
33	VLED_GND	LED Ground		
34	NC	No Connect		
35	S_PWMIN	System PWM signal Input		
36	BL_ON	LED enable pin (+3V input, +5V tolerance)		
37	NC	No Connect		
38	VLED	LED Power Supply 7V-20V		
39	VLED	LED Power Supply 7V-20V		
40	VLED	LED Power Supply 7V-20V		

Samsung Secret

5.2 LVDS Interface : Transmitter DS90CF363 or Compatible

Pin No.	Name	RGB Signal	Pin No.	Name	RGB Signal
51	TxIN0	R0	14	TxIN14	G5
52	TxIN1	R1	15	TxIN15	B0
54	TxIN2	R2	19	TxIN18	B1
55	TxIN3	R3	20	TxIN19	B2
56	TxIN4	R4	22	TxIN20	B3
3	TxIN6	R5	23	TxIN21	B4
4	TxIN7	G0	24	TxIN22	B5
6	TxIN8	G1	27	TxIN24	Hsync
7	TxIN9	G2	28	TxIN25	Vsync
11	TxIN12	G3	30	TxIN26	DE
12	TxIN13	G4	31	TxCLKIN	Clock

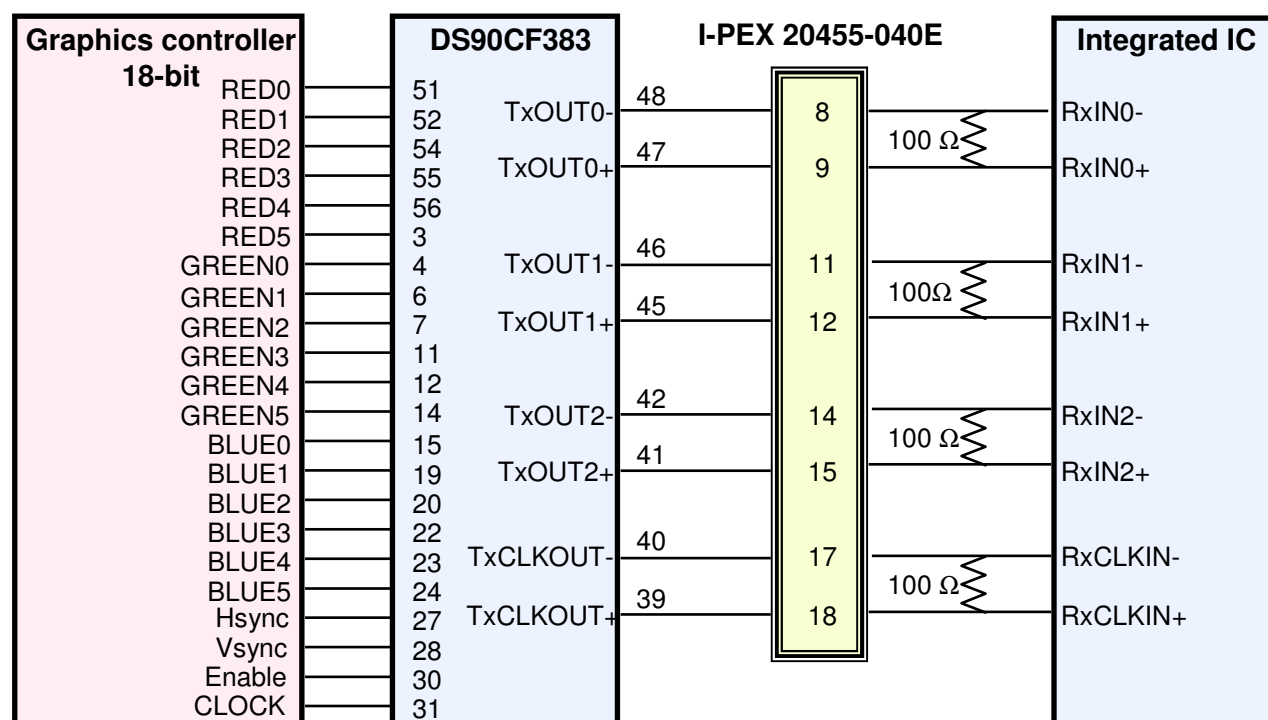
LVDS INTERFACE

Note : The LCD Module uses a 100ohm resistor between positive and negative lines of each receiver input.

Samsung Secret

5.3 Timing Diagrams of LVDS For Transmission

LVDS Receiver : Integrated T-CON

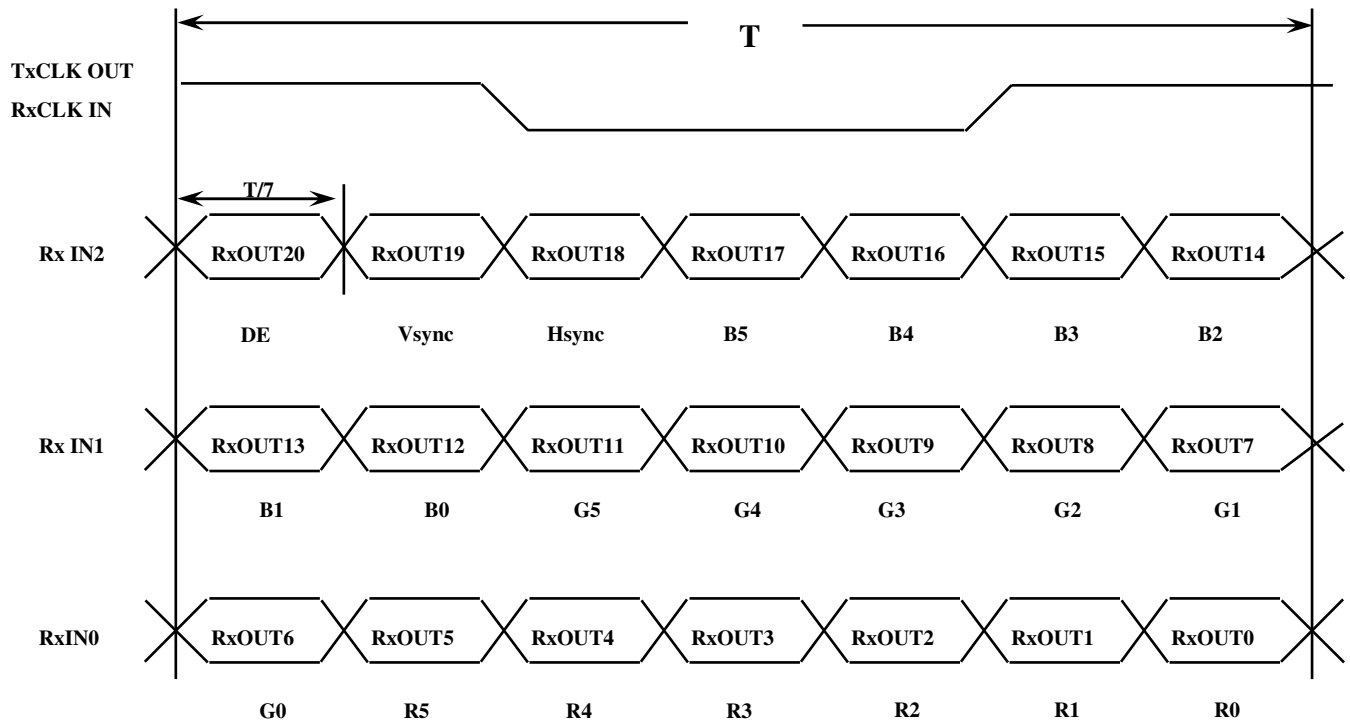

Samsung Secret

5.4 Input Signals, Basic Display Colors and Gray Scale of Each Color

Color	Display	Data Signal																Gray Scale Level	
		Red					Green					Blue							
		R0	R1	R2	R3	R4	R5	G0	G1	G2	G3	G4	G5	B0	B1	B2	B3		B4
Basic Colors	Black	0	0	0	0	0	0	0	0	0	0	0	0	0	0	0	0	0	-
	Blue	0	0	0	0	0	0	0	0	0	0	0	0	1	1	1	1	1	-
	Green	0	0	0	0	0	0	1	1	1	1	1	1	0	0	0	0	0	-
	Cyan	0	0	0	0	0	0	1	1	1	1	1	1	1	1	1	1	1	-
	Red	1	1	1	1	1	1	0	0	0	0	0	0	0	0	0	0	0	-
	Magenta	1	1	1	1	1	1	0	0	0	0	0	0	1	1	1	1	1	-
	Yellow	1	1	1	1	1	1	1	1	1	1	1	1	0	0	0	0	0	-
	White	1	1	1	1	1	1	1	1	1	1	1	1	1	1	1	1	1	-
Gray Scale Of Red	Black	0	0	0	0	0	0	0	0	0	0	0	0	0	0	0	0	0	R0
	Dark	1	0	0	0	0	0	0	0	0	0	0	0	0	0	0	0	0	R1
	↑	0	1	0	0	0	0	0	0	0	0	0	0	0	0	0	0	0	R3~R60
	:	:	:	:	:	:	:	:	:	:	:	:	:	:	:	:	:	:	
	:	:	:	:	:	:	:	:	:	:	:	:	:	:	:	:	:	:	
	↓	1	0	1	1	1	1	0	0	0	0	0	0	0	0	0	0	0	R61
	Light	0	1	1	1	1	1	0	0	0	0	0	0	0	0	0	0	0	R62
	Red	1	1	1	1	1	1	0	0	0	0	0	0	0	0	0	0	0	R63
Gray Scale Of Green	Black	0	0	0	0	0	0	0	0	0	0	0	0	0	0	0	0	0	G0
	Dark	0	0	0	0	0	0	1	0	0	0	0	0	0	0	0	0	0	G1
	↑	0	0	0	0	0	0	0	1	0	0	0	0	0	0	0	0	0	G3~G60
	:	:	:	:	:	:	:	:	:	:	:	:	:	:	:	:	:	:	
	:	:	:	:	:	:	:	:	:	:	:	:	:	:	:	:	:	:	
	↓	0	0	0	0	0	0	1	0	1	1	1	1	0	0	0	0	0	G61
	Light	0	0	0	0	0	0	0	1	1	1	1	1	0	0	0	0	0	G62
	Green	0	0	0	0	0	0	1	1	1	1	1	1	0	0	0	0	0	G63
Gray Scale Of Blue	Black	0	0	0	0	0	0	0	0	0	0	0	0	0	0	0	0	0	B0
	Dark	0	0	0	0	0	0	0	0	0	0	0	0	1	0	0	0	0	B1
	↑	0	0	0	0	0	0	0	0	0	0	0	0	0	1	0	0	0	B2
	:	:	:	:	:	:	:	:	:	:	:	:	:	:	:	:	:	:	B3~B60
	:	:	:	:	:	:	:	:	:	:	:	:	:	:	:	:	:	:	
	↓	0	0	0	0	0	0	0	0	0	0	0	0	1	0	1	1	1	
	Light	0	0	0	0	0	0	0	0	0	0	0	0	0	1	1	1	1	B62
	Blue	0	0	0	0	0	0	0	0	0	0	0	0	1	1	1	1	1	B63

Note 1) Definition of gray :

Rn: Red gray, Gn: Green gray, Bn: Blue gray (n=gray level)

Note 2) Input signal: 0 =Low level voltage, 1=High level voltage

Samsung Secret

5.5 Pixel Format in the display

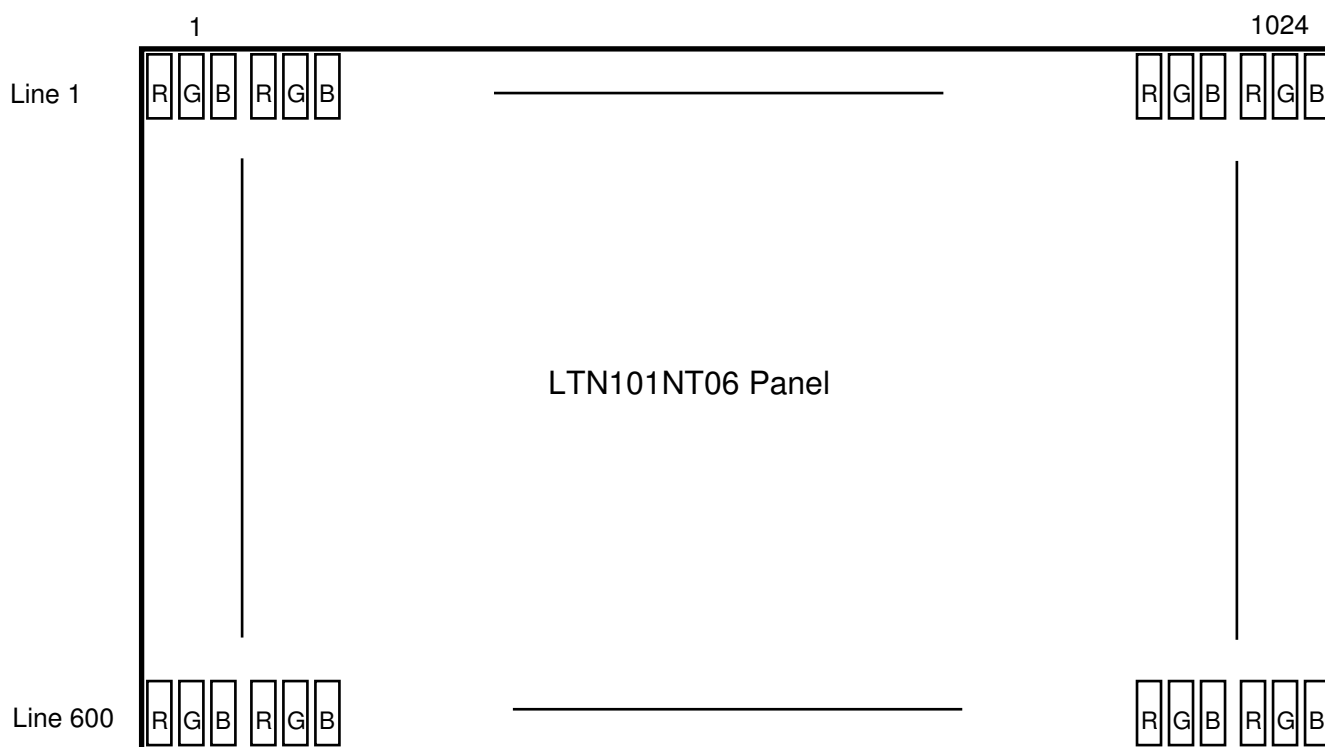

Samsung Secret

6. INTERFACE TIMING

6.1 Timing Parameters

Signal	Item	Symbol	Min.	Typ.	Max.	Unit	Note
Frame Frequency	Cycle	TV	-	673	-	Lines	
Vertical Active Display Term	Display Period	TVD	-	600	-	Lines	
One Line Scanning Time	Cycle	TH	1200	1400	1600	Clocks	
Horizontal Active Display Term	Display Period	THD	-	1024	-	Clocks	

6.2 Timing diagrams of interface signal

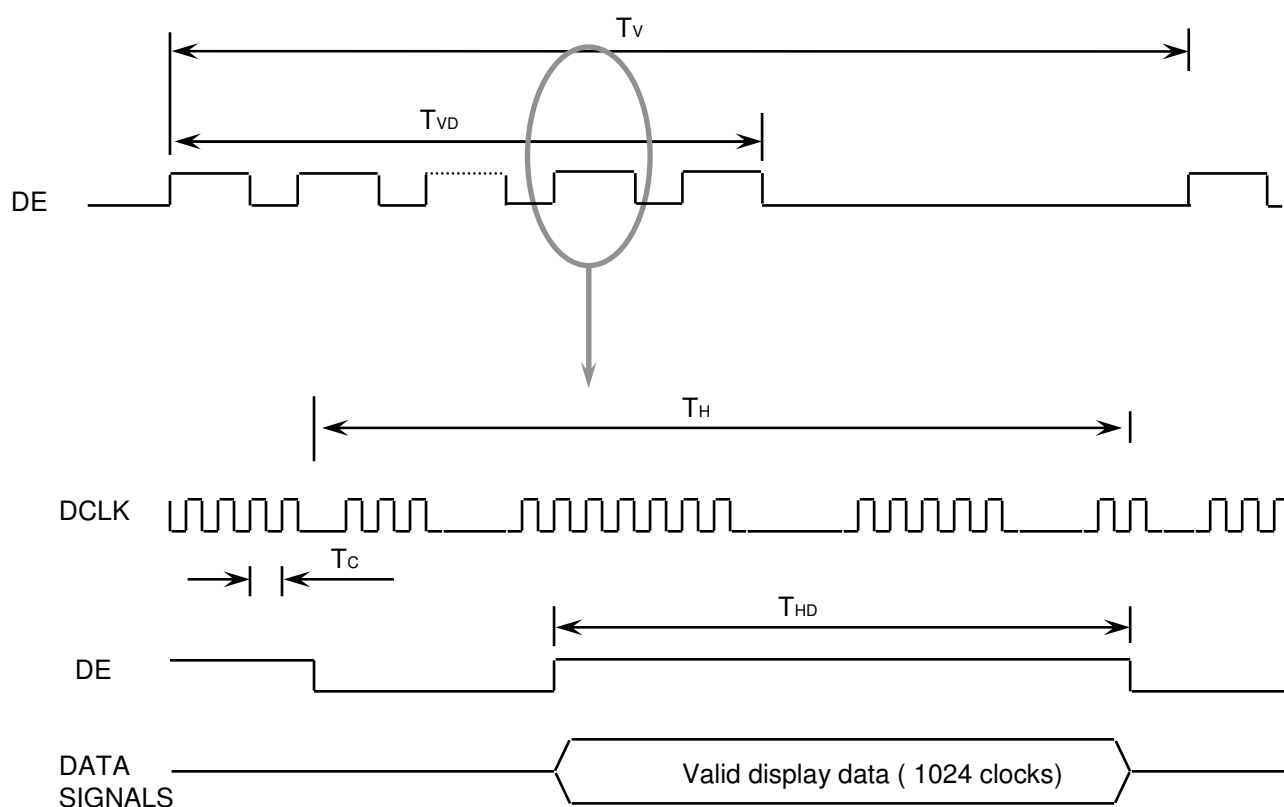

Samsung Secret

6.3 Power ON/OFF Sequence

: To prevent a latch-up or DC operation of the LCD module, the power on/off sequence should be as the diagram below.

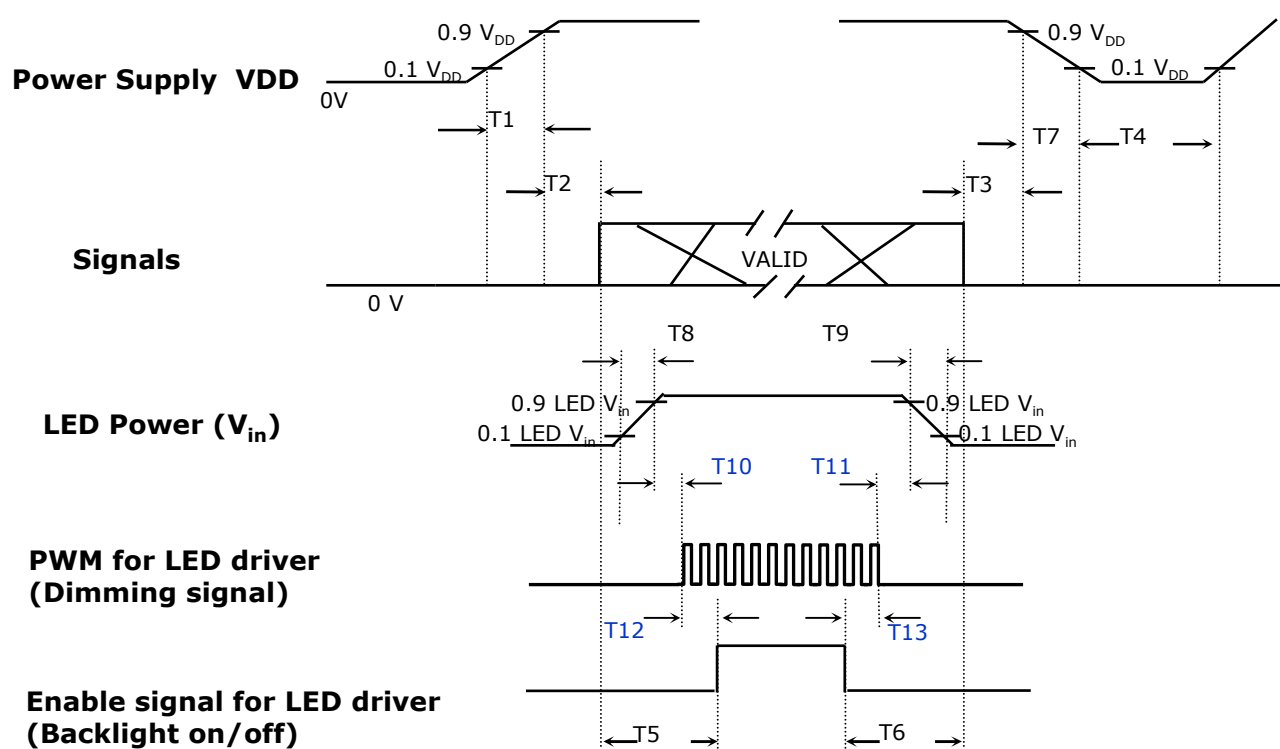

Power ON/OFF Sequence

Timing (ms)	Remarks
$0.5 < T1 \leq 10$	V _{DD} rising time from 10% to 90%
$0 < T2 \leq 50$	Delay from V _{DD} to valid data at power ON
$0 < T3 \leq 50$	Delay from valid data OFF to V _{DD} OFF at power Off
$500 \leq T4$	V _{DD} OFF time for Windows restart
$200 \leq T5$	Delay from valid data to B/L enable at power ON
$200 \leq T6$	Delay from valid data off to B/L disable at power Off
$0 < T7 \leq 10$	V _{DD} falling time from 90% to 10%
$0.5 < T8 \leq 10$	LED V _{in} rising time from 10% to 90%
$0.5 < T9 \leq 10$	LED V _{in} falling time from 90% to 10%
$0 \leq T10$	Delay from LED driver Vin rising time 90% to PWM ON
$0 \leq T11$	Delay from PWM Off to LED driver Vin falling time 10%, Must Keep rule
$0 \leq T12$	Delay from PWM ON to B/L Enable ON, Must Keep rule
$0 \leq T13$	Delay from B/L Enable Off to PWM Off

Power Sequence & Timing Parameters

Samsung Secret

6.3 Power ON/OFF Sequence

Approval

NOTE.

- (1) The supply voltage of the external system for the module input should be the same as the definition of V_{DD} .
- (2) Apply the lamp voltage within the LCD operation range. When the back-light turns on before the LCD operation or the LCD turns off before the back-light turns off, the display may momentarily become white.
- (3) In case of $V_{DD} = \text{off level}$, please keep the level of input signals on the low or keep a high impedance.
- (4) T_4 should be measured after the module has been fully discharged between power off and on period.
- (5) Interface signal shall not be kept at high impedance when the power is on.

Samsung Secret

Doc.No.	LTN101NT06	Rev.No	04-A00-G-100504	Page	22 / 32
----------------	------------	---------------	-----------------	-------------	---------

7. Mechanical Outline Dimension

Approval

Refer to the next page

Samsung Secret

Doc.No.	LTN101NT06	Rev.No	04-A00-G-100504	Page	23 / 32
----------------	------------	---------------	-----------------	-------------	---------

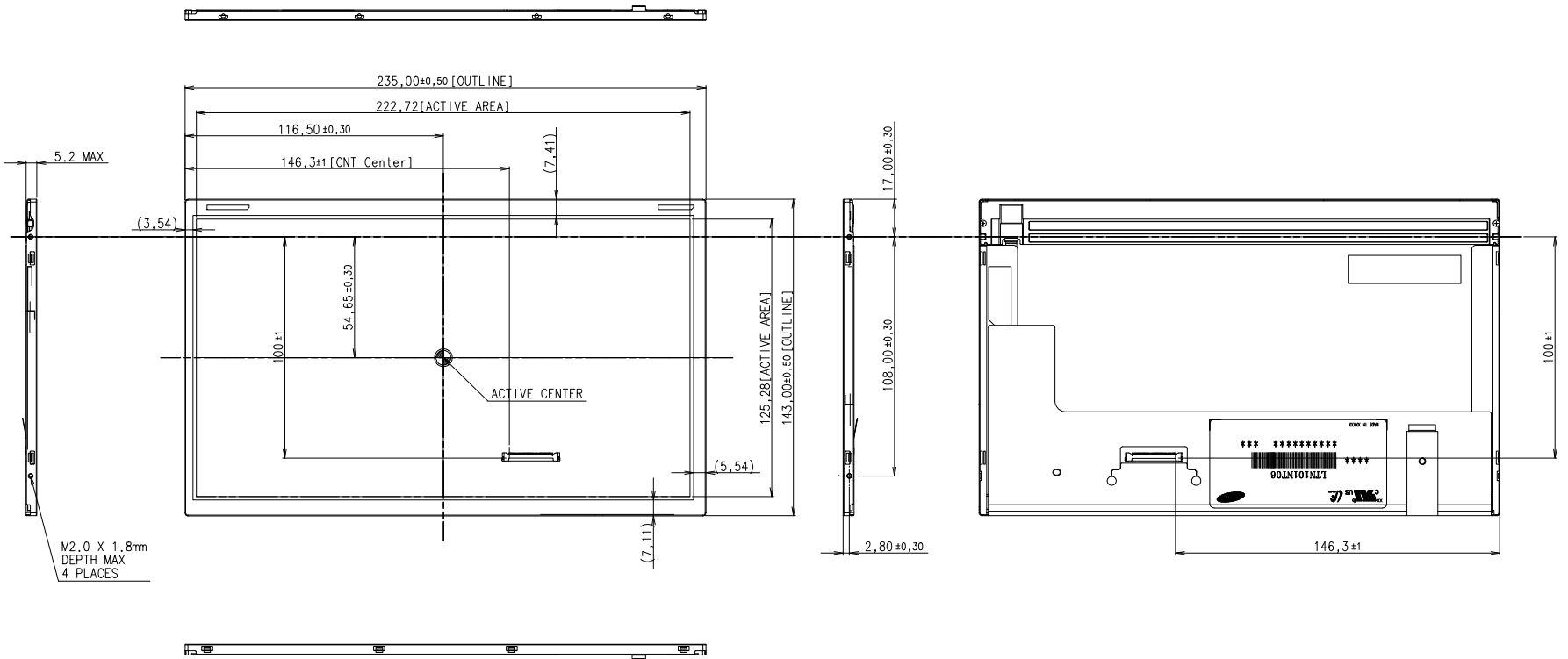

LTN101NT06-001

Samsung Confidential

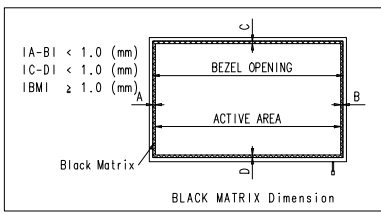

- * NOTE
- SIGNAL INTERFACE CONNECTOR TO BE SPECIFIED AS BELOW.
- MAKER : I-PEX
- INPUT : I-PEX 20455-040E-0 or EQUIVALENT(LOCK TYPE)
 - ALLOWED DEPTH OF USERHOLE SCREW INSERTION IS 1.8mm MAX.
 - CALIFERS MEASURING FORCE : 750 gf
 - USER HOLE TORQUE SPEC : 2.0 kgfcm Max(5TIMES)
 - WEIGHT SPEC : 200g Max
 - IN ORDER TO AVOID IC DAMAGE, IT IS NOT ALLOW THAT OVERLAPPING OF CABLES OR ANTENNAS, CAMERA, WLAN, WWAN OVER THESE COF LACATIONS
 - GENERAL TOLERANCE IS 0.5mm

ZD-0-0-0-0-0

REV	DATE	DESCRIPTION OF REVISION	REASON	CHK'D BY
UNI 1	mm	DRA'N BY DES'G BY CHK'ID BY APP'D BY	MODEL NAME	LTN101NT06-001
SCALE	1:1	Y.H.NM	H.S.CHN	PART/SHEET
GENERAL TOLERANCE	±0.5	2010.02.10	2010.02.10	NAME
			SPEC. NO	SHEET 1/1
SAMSUNG ELECTRONICS			CODE NO.	VER. 000

8. PACKING

1. CARTON(Internal Package)

(1) Packing Form

Corrugated fiberboard box and corrupad form as shock absorber

(2) Packing Method

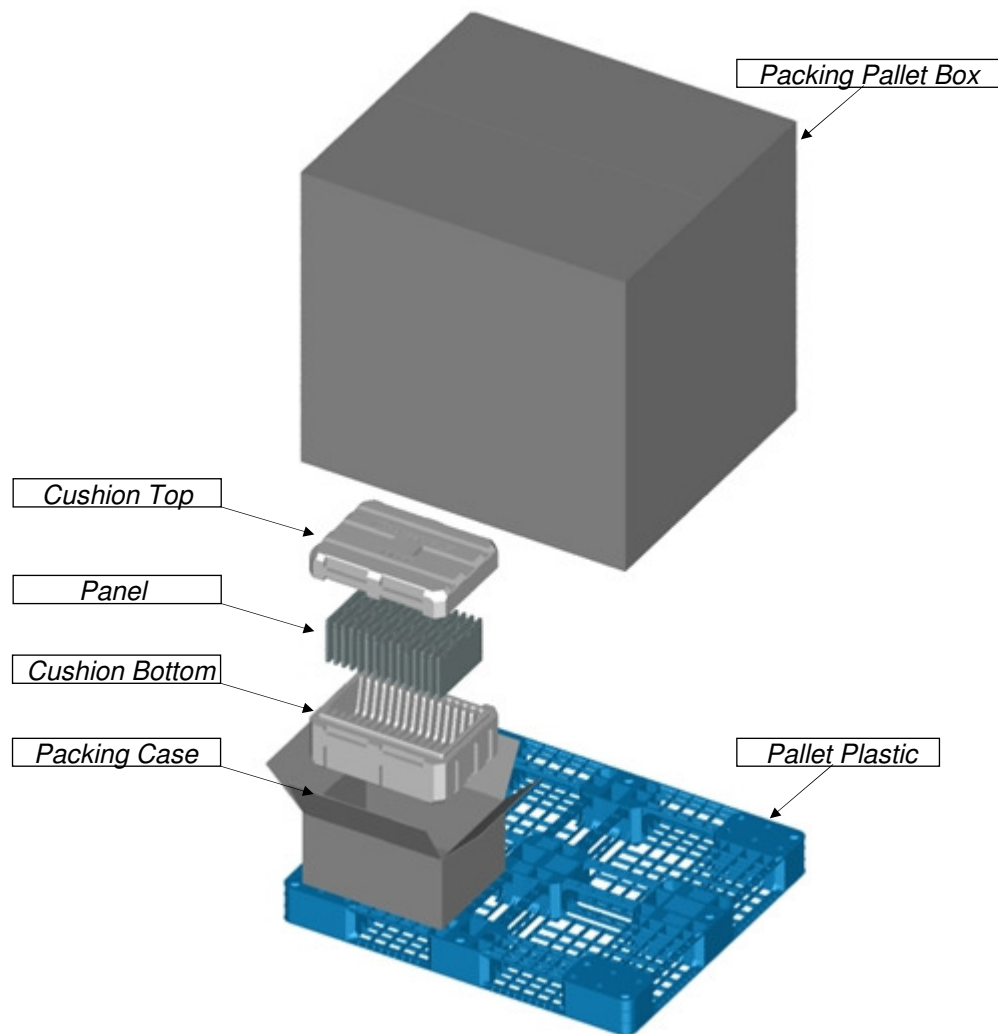

PACKING CASE

- Note 1) Total Weight : Approximately 7 kg
2) Acceptance number of piling : 30 sets
3) Carton size : 450(W) × 340(D) × 230(H)

Samsung Secret

(3)Packing Material

No	Part name	Quantity
1	Static electric protective sack	30
2	Packing case (Inner box) included shock absorber	1 set
3	Pictorial marking	2 pcs
4	Carton	1 set

9. MARKINGS & OTHERS

A nameplate bearing followed by is affixed to a shipped product at the specified location on each product.

(1)Parts number : LTN101NT06

(2)Revision code : 3 letters

(3)Lot number : X X X X XXX XX X **001**

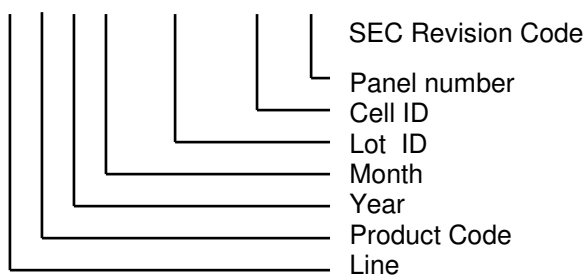

(5) Nameplate Indication

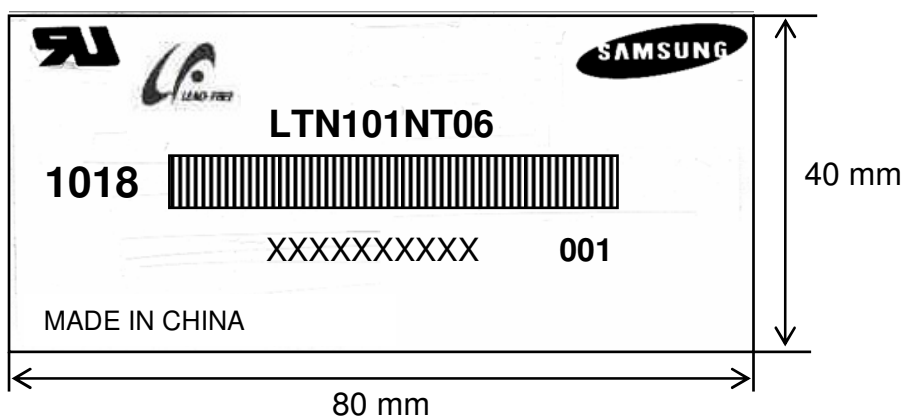

Parts name : LTN101NT06
Lot number : XXXXXXXXXXXX
Inspected work week : 1018 (2010 year, 18nd week)

Samsung Secret

High voltage caution label

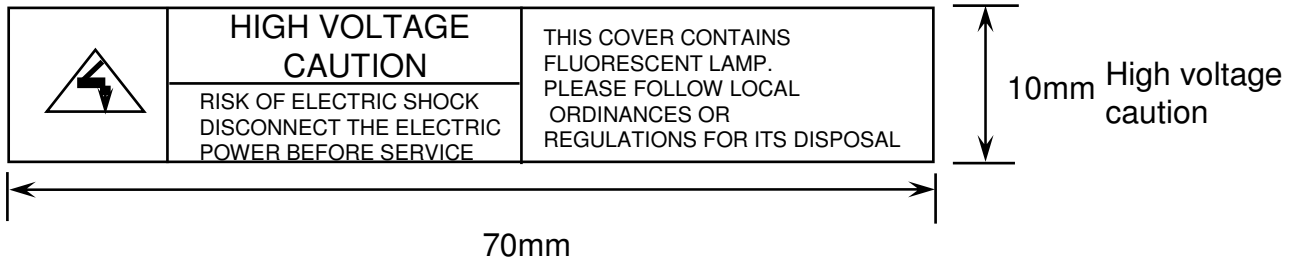

(6) Packing small box attach

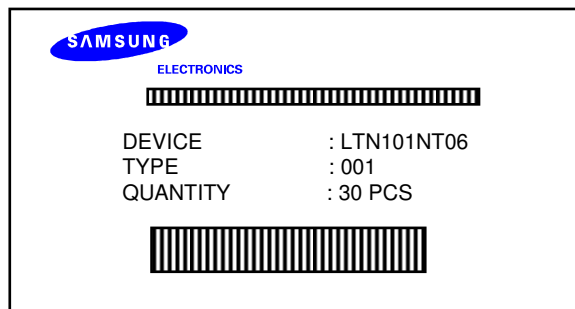

10. GENERAL PRECAUTIONS

Approval

1. Handling

- (a) When the module is assembled, It should be attached to the system firmly using every mounting holes. Be careful not to twist and bend the modules.
- (b) Refrain from strong mechanical shock and / or any force to the module. In addition to damage, this may cause improper operation or damage to the module and CCFT back-light.
- (c) Note that polarizers are very fragile and could be easily damaged. Do not press or scratch the surface harder than a HB pencil lead.
- (d) Wipe off water droplets or oil immediately. If you leave the droplets for a long time, Staining and discoloration may occur.
- (e) If the surface of the polarizer is dirty, clean it using some absorbent cotton or soft cloth.
- (f) The desirable cleaners are water, IPA (Isopropyl Alcohol) or Hexane. Do not use Ketone type materials(ex. Acetone), Ethyl alcohol, Toluene, Ethyl acid or Methyl chloride. It might permanent damage to the polarizer due to chemical reaction.
- (g) If the liquid crystal material leaks from the panel, it should be kept away from the eyes or mouth. In case of contact with hands, legs or clothes, it must be washed away thoroughly with soap.
- (h) Protect the module from static, it may cause damage to the C-MOS Gate Array IC.
- (i) Use fingerstalls with soft gloves in order to keep display clean during the incoming inspection and assembly process.
- (j) Do not disassemble the module.
- (k) Do not pull or fold the lamp wire.
- (l) Do not adjust the variable resistor which is located on the back side.
- (m) Protection film for polarizer on the module shall be slowly peeled off just before use so that the electrostatic charge can be minimized.
- (n) Pins of I/F connector shall not be touched directly with bare hands.

Samsung Secret

Doc.No.	LTN101NT06	Rev.No	04-A00-G-100504	Page	28 / 32
----------------	------------	---------------	-----------------	-------------	---------

2. STORAGE

- (a) Do not leave the module in high temperature, and high humidity for a long time. It is highly recommended to store the module with temperature from 0 to 35 °C and relative humidity of less than 70%.
- (b) Do not store the TFT-LCD module in direct sunlight.
- (c) The module shall be stored in a dark place. It is prohibited to apply sunlight or fluorescent light during the store.

3. OPERATION

- (a) Do not connect, disconnect the module in the “ Power On” condition.
- (b) Power supply should always be turned on/off by following item 6.3 “ Power on/off sequence “.
- (c) Module has high frequency circuits. Sufficient suppression to the electromagnetic interference shall be done by system manufacturers. Grounding and shielding methods may be important to minimize the interference.
- (d) The cable between the back-light connector and its inverter power supply shall be a minimized length and be connected directly . The longer cable between the back-light and the inverter may cause lower luminance of lamp(CCFT) and may require higher startup voltage (Vs).
- (e) The standard limited warranty is only applicable when the module is used for general notebook applications. If used for purposes other than as specified, SEC is not to be held reliable for the defective operations. It is strongly recommended to contact SEC to find out fitness for a particular purpose.

4. OTHERS

- (a) Ultra-violet ray filter is necessary for outdoor operation.
- (b) Avoid condensation of water. It may result in improper operation or disconnection of electrode.
- (c) Do not exceed the absolute maximum rating value. (the supply voltage variation, input voltage variation, variation in part contents and environmental temperature, so on) Otherwise the module may be damaged.
- (d) If the module displays the same pattern continuously for a long period of time, it can be the situation when the image “sticks” to the screen.
- (e) This module has its circuitry PCB's on the rear side and should be handled carefully in order not to be stressed.

Samsung Secret

Doc.No.	LTN101NT06	Rev.No	04-A00-G-100504	Page	29 / 32
----------------	------------	---------------	-----------------	-------------	---------

11. EDID

Approval

Address (HEX)	FUNCTION	Value	BIN	DEC	ASCII or Data	Notes
		HEX				
00	Header	00	00000000	0		EDID Header
01		FF	11111111	255		
02		FF	11111111	255		
03		FF	11111111	255		
04		FF	11111111	255		
05		FF	11111111	255		
06		FF	11111111	255		
07		00	00000000	0		
08	ID Manufacturer Name	4C	01001100	76	S	3 character ID
09		A3	10100011	163	E C	"SEC"
0A	ID Product Code	30	00110000	48	[0]	
0B		30	00110000	48	[0]	
0C	32-bit serial no.	00	00000000	0		
0D		00	00000000	0		
0E		00	00000000	0		
0F		00	00000000	0		
10	Week of manufacture	00	00000000	0		
11	Year of manufacture	14	00010100	20	2010	2010
12	EDID Structure Ver.	01	00000001	1	1	EDID Ver. 1.0
13	EDID revision #	03	00000011	3	3	EDID Rev. 3
14	Video input definition	80	10000000	128		
15	Max H image size	16	00010110	22	22	22 cm(approx)
16	Max V image size	0D	00001101	13	13	13 cm(approx)
17	Display Gamma	78	01111000	120	2.2	Gamma 2.2
18	Feature support	0A	00001010	10		
19	Red/green low bits	85	10000101	133		10000111
1A	Blue/white low bits	95	10010101	149		11111110
1B	Red x/ high bits	99	10011001	153	0.600	Red x0.600= 1001010010
1C	Red y	57	01010111	87	0.340	Red y0.340= 0101011100
1D	Green x	4F	01001111	79	0.310	Green x0.310= 0100111101
1E	Green y	8F	10001111	143	0.560	Green y0.560= 1000110011
1F	Blue x	26	00100110	38	0.150	Blue x0.155= 0010011111
20	Blue y	21	00100001	33	0.130	Blue y0.155= 0010011111
21	White x	50	01010000	80	0.313	White x0.313= 0101000001
22	White y	54	01010100	84	0.329	White y0.329= 0101010001

Samsung Secret

11. EDID

Approval

23	Established timing 1	00	00000000	0		
24	Established timing 2	00	00000000	0		
25	Established timing 3	00	00000000	0		
26	Standard timing #1	01	00000001	1		not used
27		01	00000001	1		
28	Standard timing #2	01	00000001	1		not used
29		01	00000001	1		
2A	Standard timing #3	01	00000001	1		not used
2B		01	00000001	1		
2C	Standard timing #4	01	00000001	1		not used
2D		01	00000001	1		
2E	Standard timing #5	01	00000001	1		not used
2F		01	00000001	1		
30	Standard timing #6	01	00000001	1		not used
31		01	00000001	1		
32	Standard timing #7	01	00000001	1		not used
33		01	00000001	1		
34	Standard timing #8	01	00000001	1		not used
35		01	00000001	1		
36	Detailed timing/monitor descriptor #1	2C	00101100	44	54.2	Main clock= 54.2 MHz(@60Hz)
37		15	00010101	21		
38		00	00000000	0	1024	Hor active=1024 pixels
39		40	01000000	64	320	Hor blanking=320 pixels
3A		41	01000001	65		4bit : 4bit
3B		58	01011000	88	600	Vertical active=600 lines
3C		46	01000110	70	70	Vertical blanking=70 lines
3D		20	00100000	32		4bit : 4bit
3E		18	00011000	24	24	Hor sync. Offset=24 pixels
3F		88	10001000	136	136	H sync. Width=136 pixels
40		36	00110110	54	3 6	V sync. Offset=3 lines V sync. Width=6 lines
41		00	00000000	0		2bit : 2bit :2bit :2bit
42		DF	11011111	223	223	H image size= 223 mm(approx)
43		7D	01111101	125	125	V image size = 125 mm(approx)
44		00	00000000	0		
45		00	00000000	0		No Horizontal Border
46		00	00000000	0		No Vertical Border
47	19	00011001	25			
48	Detailed timing/monitor descriptor #2	00	00000000	0		Manufacturer Specified (Timing)
49		00	00000000	0		
4A		00	00000000	0		
4B		0F	00001111	15		
4C		00	00000000	0		
4D		00	00000000	0		
4E		00	00000000	0		
4F		00	00000000	0		
50		00	00000000	0		Value=HSPWmin / 2
51		00	00000000	0		Value=HSPWmax / 2
52		00	00000000	0		Value=Thbpmin / 2
53		00	00000000	0		Value=Thbpmax / 2
54		00	00000000	0		Value=VSPWmin / 2
55		00	00000000	0		Value=VSPWmax / 2
56		00	00000000	0		Value=Tvbpmin / 2
57		00	00000000	0		Value=Tvbpmax / 2
58		23	00100011	35		Thpmin=value*2 + HA pixelclks
59	87	10000111	135		Thpmax=value*2 + HA pixelclks	
	02	00000010	2		Tvpmin=value*2 + VA lines	
	64	01100100	100		Tvpmax=value*2 + VA lines	
	00	00000000	0		Module revision	

Samsung Secret

11. EDID

Approval

5A	Detailed timing/monitor descriptor #3	00	00000000	0		ASCII Data String Tag
5B		00	00000000	0		
5C		00	00000000	0		
5D		FE	11111110	254		
5E		00	00000000	0		
5F		53	01010011	83	[S]	
60		41	01000001	65	[A]	
61		4D	01001101	77	[M]	
62		53	01010011	83	[S]	
63		55	01010101	85	[U]	
64		4E	01001110	78	[N]	
65		47	01000111	71	[G]	
66		0A	00001010	10	[^]	
67		20	00100000	32	[]	
68		20	00100000	32	[]	
69		20	00100000	32	[]	
6A		20	00100000	32	[]	
6B		20	00100000	32	[]	
6C		Detailed timing/monitor descriptor #4	00	00000000	0	
6D	00		00000000	0		
6E	00		00000000	0		
6F	FE		11111110	254		
70	00		00000000	0		
71	4C		01001100	76	[L]	
72	54		01010100	84	[T]	
73	4E		01001110	78	[N]	
74	31		00110001	49	[1]	
75	30		00110000	48	[0]	
76	31		00110001	49	[1]	
77	4E		01001110	78	[N]	
78	54		01010100	84	[T]	
79	30		00110000	48	[0]	
7A	36		00110110	54	[6]	
7B	30		00110000	48	[0]	
7C	30		00110000	48	[0]	
7D	31		00110001	49	[1]	
7E	Extension Flag		00	00000000	0	
7F	Checksum	D0	11010000	208		

Samsung Secret