

**SAMSUNG****ELECTRONICS**

Approval



TO : Lenovo / Wistron

DATE : July 9. 2008

**SAMSUNG TFT-LCD****MODEL NO.: LTN121AP02-001**

**NOTE** : Green product (Complied with RoHS requirement)  
 PVA mode (Normally Black)  
 Surface type [Anti-Glare]

Any Modification of Spec is not allowed without SEC' permission

APPROVED BY :

PREPARED BY : **Mobile LCD, Application Engineering Part****SAMSUNG ELECTRONICS CO., LTD.****Samsung Secret**

Doc.No.	LTN121AP02-001	Rev.No	04-A00-S-080709	Page	1 / 30
---------	----------------	--------	-----------------	------	--------

Approval

**CONTENTS**

Revision History	----- ( 2 )
General Description	----- ( 3 )
1. Absolute Maximum Ratings	----- ( 4 )
1.1 Absolute Ratings of environment	
1.2 Electrical Absolute Ratings	
2. Optical Characteristics	----- ( 6 )
3. Electrical Characteristics	----- ( 10 )
3.1 TFT LCD Module	
3.2 Backlight Unit	
4. Block Diagram	----- ( 13 )
4.1 TFT LCD Module	
4.2 Backlight Unit	
5. Input Terminal Pin Assignment	----- ( 14 )
5.1 Input Signal & Power	
5.2 LVDS Interface	
5.3 Backlight Unit	
5.4 Timing Diagrams of LVDS For Transmitting	
5.5 Input Signals, Basic Display Colors and Gray Scale of Each Color.	
5.6 Pixel format	
6. Interface Timing	----- ( 20 )
6.1 Timing Parameters(DE Mode)	
6.2 Timing Diagrams of interface Signal (DE Mode)	
6.3 Power ON/OFF Sequence	
7. Outline Dimension	----- ( 22 )
8. Packing	----- ( 24 )
9. Product Marking & Others	----- ( 26 )
10.General Precautions	----- ( 27 )
11. EDID	----- ( 29 )

**Samsung Secret**

<b>Doc.No.</b>	LTN121AP02-001	<b>Rev.No</b>	04-A00-S-080709	<b>Page</b>	2 / 30
----------------	----------------	---------------	-----------------	-------------	--------

## REVISION HISTORY

Approval

Date	Revision No.	Page	Summary
Mar 3, 2008	P00	All	LTN121AP02-001 Model spec was issued first.
June. 6, 2008	P01	P28-30	EDID was revised. (AS-IS) checksum "6A" → (TO-BE) "8D"
July 9. 2008	A00	All	Approval specification of LTN121AP02-001 was issued.

**Samsung Secret**

<b>Doc.No.</b>	LTN121AP02-001	<b>Rev.No</b>	04-A00-S-080709	<b>Page</b>	3 / 30
----------------	----------------	---------------	-----------------	-------------	--------

Approval

**GENERAL DESCRIPTION****DESCRIPTION**

LTN121AP02-001 is a color active matrix TFT (Thin Film Transistor) liquid crystal display (LCD) that uses amorphous silicon TFT as a switching devices. This model is composed of a TFT LCD panel, a driver circuit and a backlight system. The resolution of a 12.1" contains 1280 X 800 pixels and can display up to 262,144 colors. 6 O'clock direction is the Optimum viewing angle.

**FEATURES**

- Wide viewing angle
- High contrast ratio
- WXGA (1280X800 pixels) resolution
- Low power consumption
- DE (Data enable) only mode.
- LVDS Interface with 1 pixel / clock (1 channel)
- Auto-Recovery Function

**APPLICATIONS**

- Tablet PC
- Display terminals for AV application products
- If the usage of this product is not for PC application, but for others, please contact SEC

**GENERAL INFORMATION**

ITEM	SPECIFICATION	UNIT	NOTE
Display area	261.12(H) x 163.2(V) ( 12.1" wide diagonal )	mm	
Driver element	a-si TFT active matrix		
Display colors	262,144		
Number of pixel	1280 x 800 (WXGA)	pixel	
Pixel arrangement	RGB vertical stripe	mm	
Pixel pitch	0.204(H) x 0.204(V)		
Display Mode	Normally Black		
Surface treatment	Anti-glare (HAZE 44, HARD-COATING 3H)		

**Samsung Secret**

<b>Doc.No.</b>	LTN121AP02-001	<b>Rev.No</b>	04-A00-S-080709	<b>Page</b>	4 / 30
----------------	----------------	---------------	-----------------	-------------	--------

Approval

## Mechanical Information

ITEM		MIN.	TYP.	MAX.	NOTE
Module size	Horizontal (H)	275.3	275.8	276.3	
	Vertical (V)	177.5	178.0	178.5	
	Depth (D)	-	6.3	6.6	
Weight		-	285g	300g	

## 1. ABSOLUTE MAXIMUM RATINGS

## 1.1 ENVIRONMENTAL ABSOLUTE RATINGS

Item	Symbol	Min.	Max.	Unit	Note
Storage temperate	TSTG	-20	60	°C	(1)
Operating temperate (Temperature of glass surface)	TOPR	0	50	°C	(1)
Shock ( non-operating )	Snop	-	240	G	(2),(4)
Vibration (non-operating)	Vnop	-	2.41	G	(3),(4)

Note (1) Temperature and relative humidity are shown in the figure below.

95 % RH Max. ( $40\text{ }^{\circ}\text{C} \geq T_a$ )

Maximum wet - bulb temperature at  $39\text{ }^{\circ}\text{C}$  or less. ( $T_a > 40\text{ }^{\circ}\text{C}$ ) No condensation

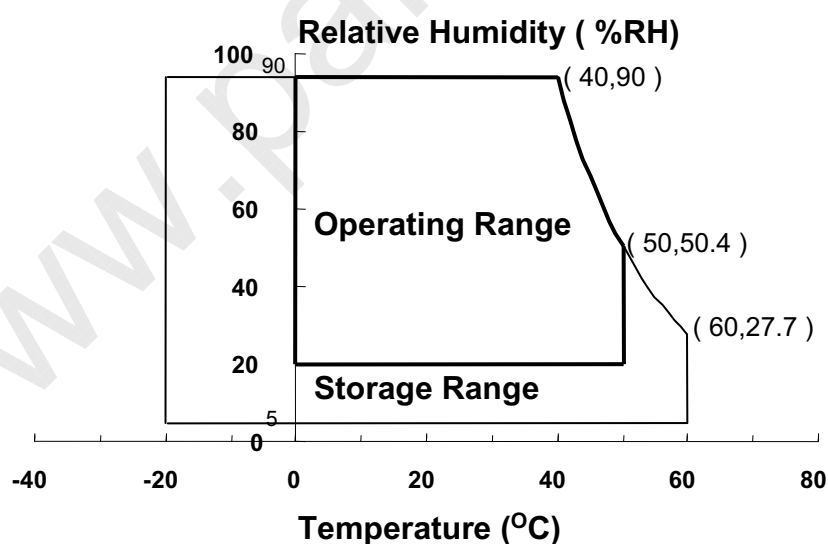

(2) 2ms, half sine wave, one time for  $\pm X, \pm Y, \pm Z$ .

(3) 5 - 500 Hz, random vibration, 30min for X, Y, Z.

(4) At testing Vibration and Shock, the fixture in holding the Module to be tested have to be hard and rigid enough so that the Module would not be twisted or bent by the fixture.

Samsung Secret

Doc.No.	LTN121AP02-001	Rev.No	04-A00-S-080709	Page	5 / 30
---------	----------------	--------	-----------------	------	--------

Approval

## 1.2 ELECTRICAL ABSOLUTE RATINGS

## (1) TFT LCD MODULE

 $V_{DD} = 3.3V, V_{SS} = GND = 0V$ 

Item	Symbol	Min.	Max.	Unit	Note
Power Supply Voltage	$V_{DD}$	$V_{DD} - 0.3$	$V_{DD} + 0.3$	V	(1)
Logic Input Voltage	$V_{IN}$	$V_{DD} - 0.3$	$V_{DD} + 0.3$	V	(1)

Note (1) Within  $T_a$  ( $25 \pm 2 \text{ }^\circ\text{C}$ )

## (2) BACK-LIGHT UNIT

 $T_a = 25 \pm 2 \text{ }^\circ\text{C}$ 

Item	Symbol	Min.	Max.	Unit	Note
Lamp Current	$I_L$	2.0	7.0	mArms	(1)
Lamp frequency	$F_L$	40	80	kHz	(1)

Note 1) Permanent damage to the device may occur if maximum values are exceeded

Functional operation should be restricted to the conditions described under normal operating conditions.

Samsung Secret

Doc.No.	LTN121AP02-001	Rev.No	04-A00-S-080709	Page	6 / 30
---------	----------------	--------	-----------------	------	--------

Approval

## 2. OPTICAL CHARACTERISTICS

The following items are measured under stable conditions. The optical characteristics should be measured in a dark room or equivalent state with the methods shown in Note (5).

Measuring equipment : SR-3

\* Ta = 25 ± 2 °C, V<sub>DD</sub>=3.3V, fv= 60Hz, fd<sub>CLK</sub>=76.77MHz, IL = 6.0 mA

Item	Symbol	Condition	Min.	Typ.	Max	Unit	Note
Contrast Ratio (5 Points)	CR	Normal Viewing Angle $\phi = 0$ $\theta = 0$	800	1000	-	-	(1), (2), (5)
Response Time at Ta ( Rising + Falling )	T <sub>RT</sub>		-	25	35	msec	(1), (3)
Average Luminance of White (5 Points)	Y <sub>L,AVE</sub>		170	210	-	cd/m <sup>2</sup>	I <sub>L</sub> =6.0mA (1), (4)
Color Chromaticity ( CIE )	Red	R <sub>X</sub>	0.572	0.602	0.632	-	(1), (5)
		R <sub>Y</sub>	0.307	0.337	0.367		
	Green	G <sub>X</sub>	0.300	0.330	0.360		
		G <sub>Y</sub>	0.513	0.543	0.573		
	Blue	B <sub>X</sub>	0.123	0.153	0.183		
		B <sub>Y</sub>	0.096	0.126	0.156		
	White	W <sub>X</sub>	0.285	0.313	0.341		
		W <sub>Y</sub>	0.309	0.329	0.349		
Viewing Angle	Hor.	$\theta_L$	-	85	-	Degrees	(1), (5)
		$\theta_H$	-	85	-		
	Ver.	$\phi_H$	-	85	-		
		$\phi_L$	-	85	-		
5 points White Variation	$\delta_L$		60	-	-	%	(6)
13 Points White Variation	$\delta_L$		45	-	-	%	(6)

**Samsung Secret**

Doc.No.	LTN121AP02-001	Rev.No	04-A00-S-080709	Page	7 / 30
---------	----------------	--------	-----------------	------	--------

Approval

Note 1) Definition of Viewing Angle : Viewing angle range( $10 \leq C/R$ )

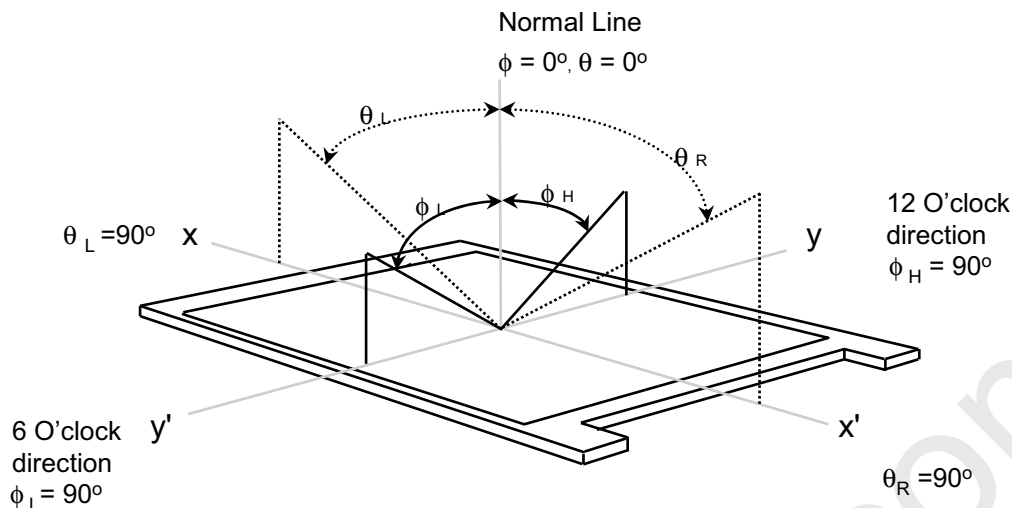

Note 2) Definition of Contrast Ratio (CR) : Ratio of gray max (Gmax) ,gray min (Gmin) at 5 points(4, 5, 7, 9, 10)

$$CR = \frac{CR(4) + CR(5) + CR(7) + CR(9) + CR(10)}{5}$$

Points : (4) , (5) , (7) , (9) , (10) at the figure of Note (6).

Note 3) Definition of Response time :

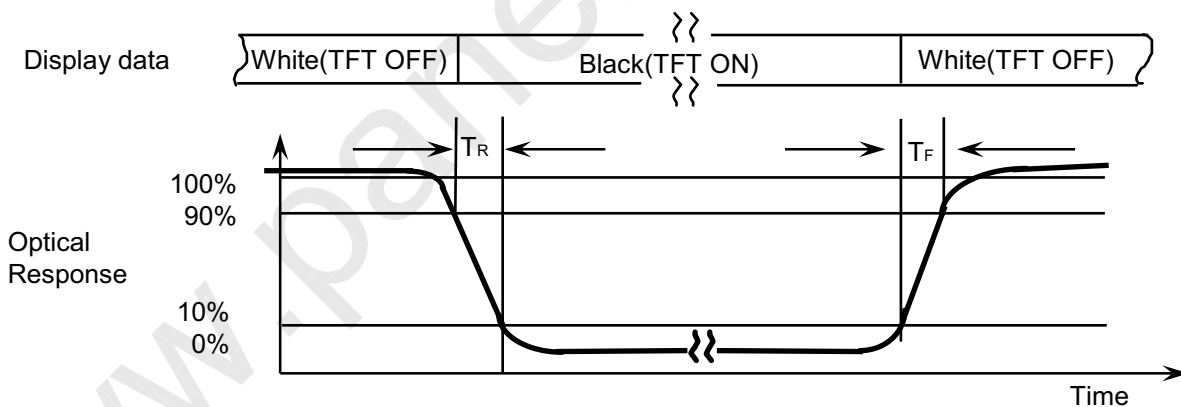

Note 4) Definition of Average Luminance of White : measure the luminance of white at 5 points.

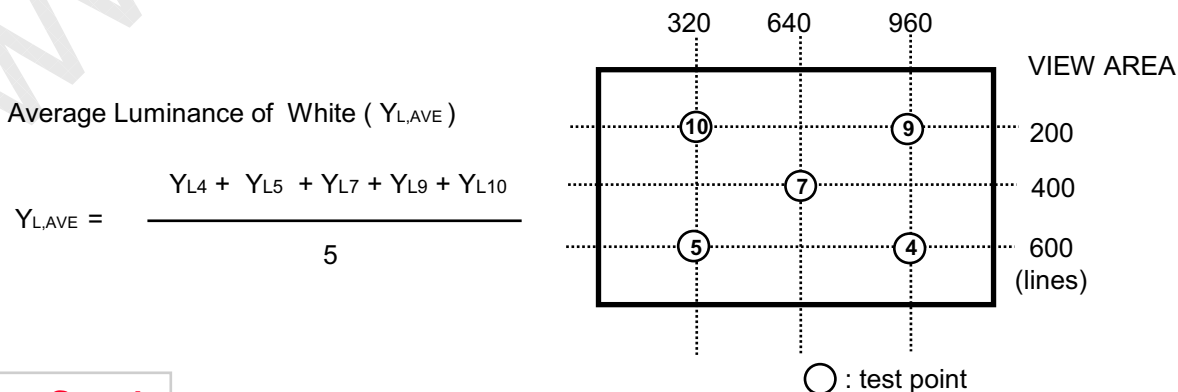

Samsung Secret



Approval

Note 5) After stabilizing and leaving the panel alone at a given temperature for 30 min , the measurement should be executed. Measurement should be executed in a stable, windless, and dark room. 30 min after lighting the backlight. This should be measured in the center of screen.  
 Lamp current : 6.0mA ( Inverter : SIC-130T )  
 Environment condition : Ta = 25 ± 2 °C

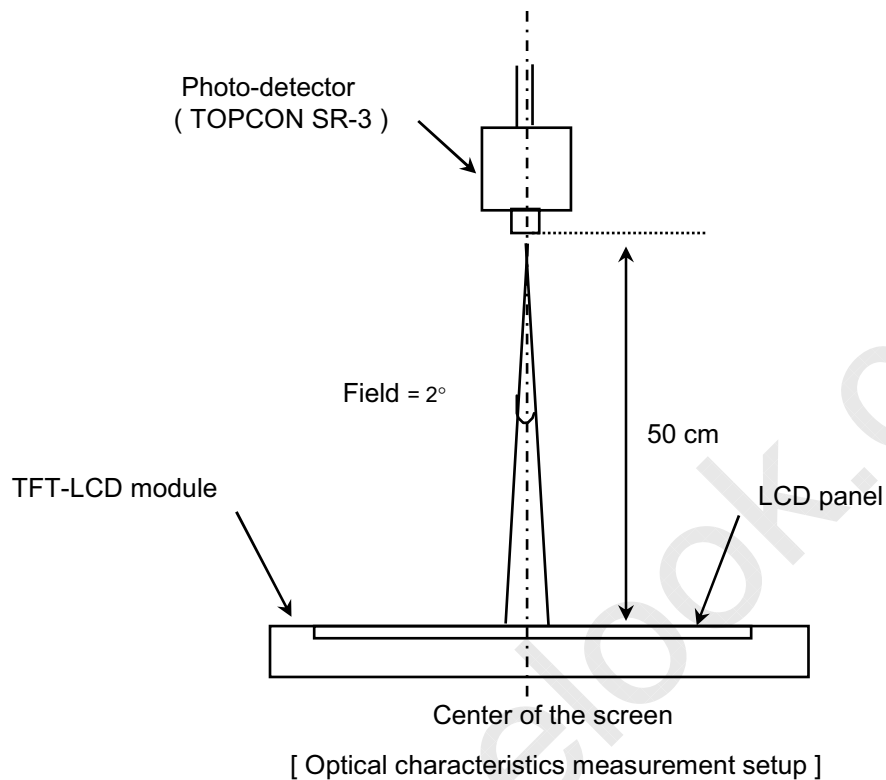

Note 6) Definition of 13 points white variation ( $\delta L$ ), CR variation( $C_{VER}$ ) [ ① ~ ⑬ ]

$$\delta L = \frac{\text{Minimum luminance of 13 points}}{\text{Maximum luminance of 13 points}}$$

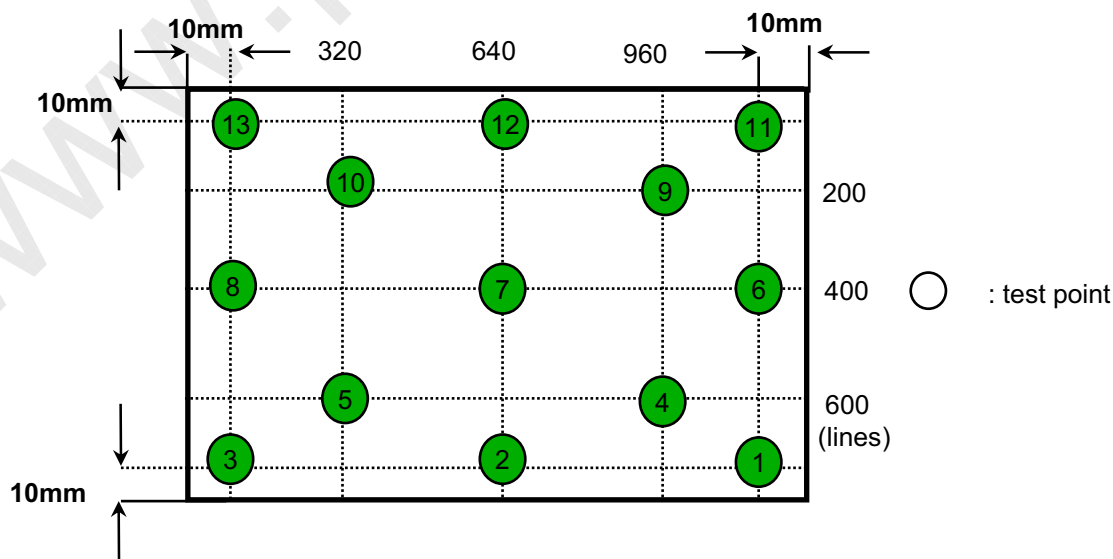

**Samsung Secret**

Doc.No.	LTN121AP02-001	Rev.No	04-A00-S-080709	Page	9 / 30
---------	----------------	--------	-----------------	------	--------

### 3. ELECTRICAL CHARACTERISTICS

Approval

#### 3.1 TFT LCD MODULE

Ta=25 ± 2 °C

ITEM		SYMBOL	MIN	TYP	MAX	UNIT	NOTE	
Voltage of Power Supply		V <sub>DD</sub>	3.0	3.3	3.6	V		
Differential Input Voltage for LVDS Receiver Threshold	High	V <sub>IH</sub>	-	-	+100	mV	V <sub>CM</sub> =+1.2V	
	Low	V <sub>IL</sub>	-100	-	-	mV		
Vsync Frequency	60Hz	Hsync Freq	F <sub>H</sub>	46.38	48.96	60	KHz	
		Main Freq	F <sub>DCLK</sub>	60.99	76.77	105	MHz	
	50Hz	Hsync Freq	F <sub>H</sub>	38.65	40.80	50	KHz	
		Main Freq	F <sub>DCLK</sub>	50.82	63.97	87.5	MHz	
	40Hz	Hsync Freq	F <sub>H</sub>	30.92	32.64	40	KHz	
		Main Freq	F <sub>DCLK</sub>	40.66	51.18	70	MHz	
Rush Current		I <sub>RUSH</sub>	-	-	1.5	A	(4)	
Current of Power Supply		White	I <sub>DD</sub>	-	270	-	mA	(2),(3)*a
		Mosaic		-	260	-	mA	(2),(3)*b
		WinXP Pattern		-	250	-	mA	(2),(3)*c
		Max Pattern		-	290	330	mA	(2),(3)*d

Note (1) Display data pins and timing signal pins should be connected.(GND=0V)

(2) f<sub>v</sub>=60Hz, f<sub>DCLK</sub> =76.77MHZ, V<sub>dd</sub> = 3.3V , DC Current.

(3) Power dissipation pattern

\*a) White Pattern

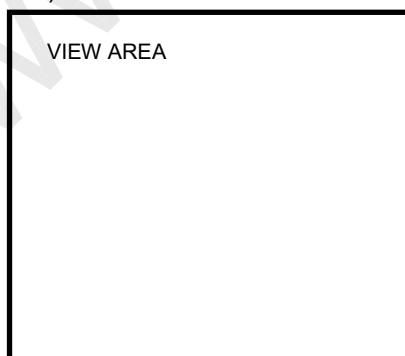

\*b) Mosaic Pattern

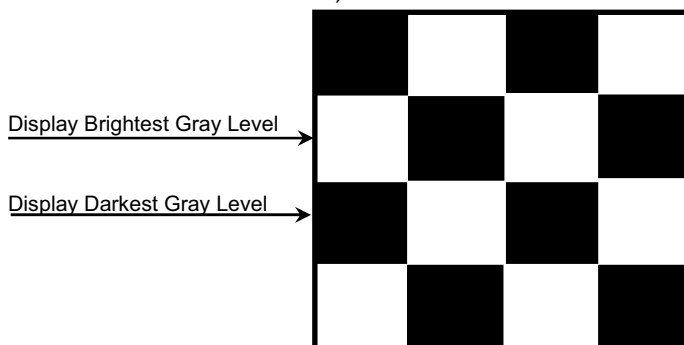

**Samsung Secret**

Doc.No.	LTN121AP02-001	Rev.No	04-A00-S-080709	Page	10 / 30
---------	----------------	--------	-----------------	------	---------

Approval

\*c) 1dot Vertical stripe pattern

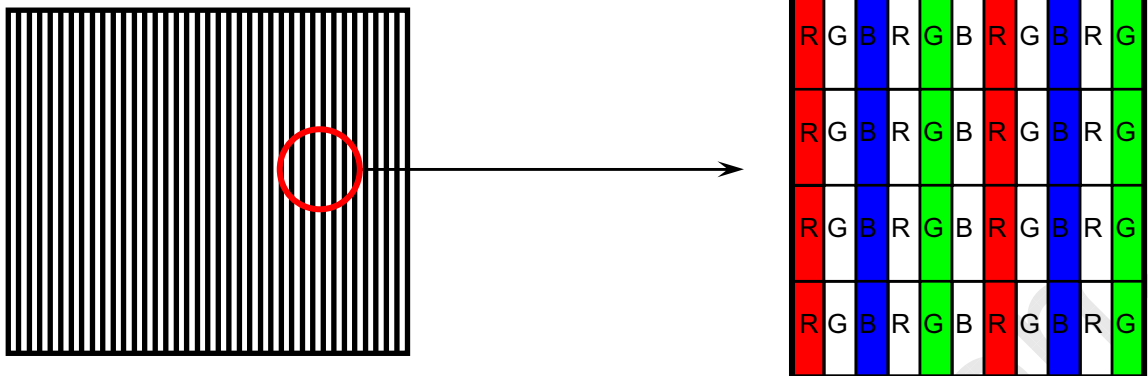

4) Rush current measurement condition

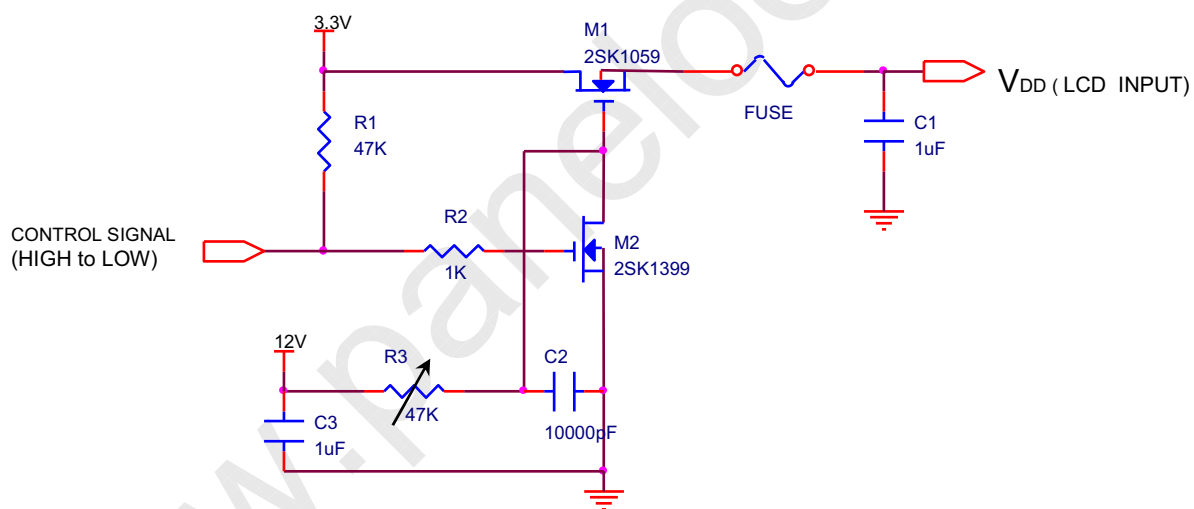

V<sub>DD</sub> rising time is 470us

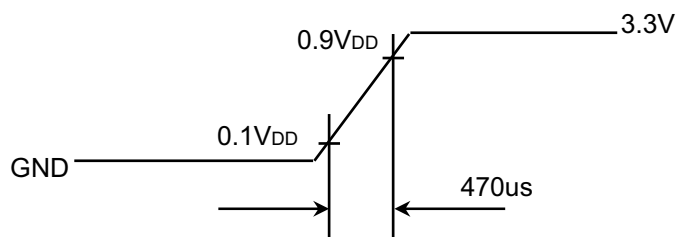

**Samsung Secret**

Doc.No.	LTN121AP02-001	Rev.No	04-A00-S-080709	Page	11 / 30
---------	----------------	--------	-----------------	------	---------

Approval

### 3.2 BACK-LIGHT UNIT

The backlight system is an edge-lighting type with a single CCFT ( Cold Cathode Fluorescent Tube ).  
The characteristics of a single lamp are shown in the following table.

-INVERTER : SEM SIC 130T

-Lamp : SS18C2700N6580C2702600S

Ta= 25 ± 2 °C

Item	Symbol	Min.	Typ.	Max.	Unit	Note
Lamp Current	I <sub>L</sub>	3.0	6.0	6.5	mArms	(1)
Lamp Voltage	V <sub>L</sub>	-	605	-	Vrms	I <sub>L</sub> = 6.0mA
Frequency	f <sub>L</sub>	50	60	65	KHz	(2)
Power Consumption	P <sub>L</sub>		3.8		W	(3) I <sub>L</sub> = 6.0mA
Operating Life Time	Hr	12,000			Hour	(4)
Startup Voltage	V <sub>s</sub>			1,030	Vrms	25°C, (5)
				1,235	Vrms	0°C, (5)
Lamp Start-up time	T <sub>s</sub>	-	-	1.0	sec	

**Note) The waveform of the inverter output voltage must be area symmetric and the design of the inverter must have specifications for the modularized lamp.**

The performance of the backlight, for example life time or brightness, is much influenced by the characteristics of the DC-AC inverter for the lamp. So all the parameters of an inverter should be carefully designed so as not to produce too much leakage current from high-voltage output of the inverter. When you design or order the inverter, please make sure that a poor lighting caused by the mismatch of the backlight and the inverter(miss lighting, flicker, etc.) never occur. When you confirm it, the module should be operated in the same condition as it is installed in your instrument.

Note (1) Lamp current is measured with a high frequency current meter as shown below.

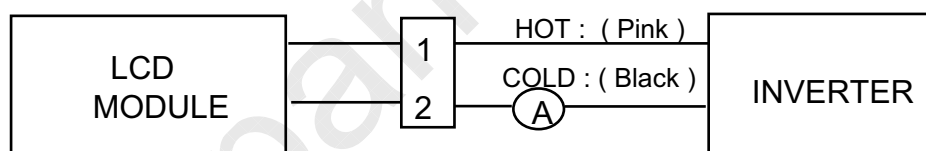

(2) Lamp frequency may produce interference with horizontal synchronous frequency and this may cause line flow on the display. Therefore lamp frequency should be detached from the horizontal synchronous frequency and its harmonics as far as possible in order to avoid interference.

(3) Refer to I<sub>L</sub> × V<sub>L</sub> to calculate.

(4) Life time (Hr) of a lamp can be defined as the time in which it continues to operate under the condition Ta= 25 ± 2 °C and I<sub>L</sub> = 6.0 mArms until one of the following event occurs.

1. When the brightness becomes 50% or lower than the original.
2. When the Effective ignition length becomes 80% or lower than the original value.  
(Effective ignition length is defined as an area that has less than 70% brightness compared to the brightness in the center point.)

(5) The inverter open voltage - this voltage should be measured after ballast capacitor- have to be larger than the lamp startup voltage, otherwise backlight may has blinking for a moment after turns on or not be turned on.

If an inverter has shutdown function it should keep its open voltage for longer than 1 second even if lamp connector open.

**Samsung Secret**

Doc.No.	LTN121AP02-001	Rev.No	04-A00-S-080709	Page	12 / 30
---------	----------------	--------	-----------------	------	---------

Approval

### 4. BLOCK DIAGRAM

#### 4.1 TFT LCD Module

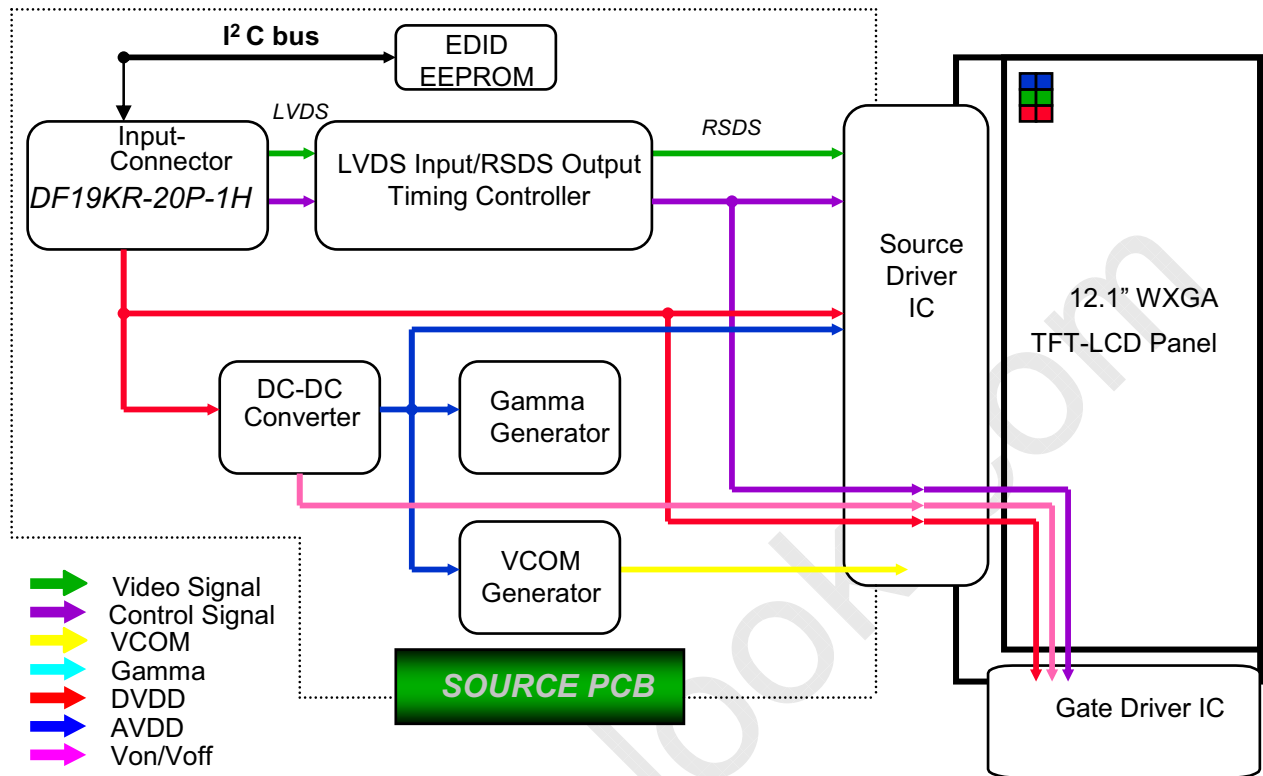

#### 4.2 BACK-LIGHT UNIT

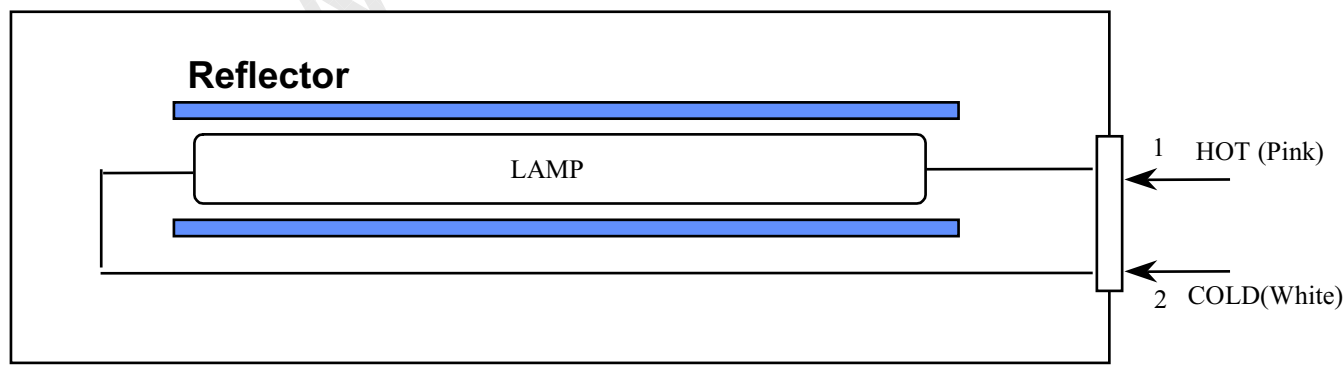

Note) The output of the inverter may change according to the material of the reflector.

**Samsung Secret**

Doc.No.	LTN121AP02-001	Rev.No	04-A00-S-080709	Page	13 / 30
---------	----------------	--------	-----------------	------	---------

Approval

## 5. INPUT TERMINAL PIN ASSIGNMENT

### 5.1. Input Signal & Power LVDS, Connector : DF-19KR-20P-1H(Hirose)

No.	Symbol	Function	Polarity	Remarks
1	VSS	Ground		
2	VDD	POWER SUPPLY +3.3V		
3	VDD	POWER SUPPLY +3.3V		
4	VEEDID	DDC 3.3V Power		
5	N.C	No connection		
6	CLKEDID	DDC Clock		
7	DATAEDID	DDC data		
8	RxIN0-	LVDS Differential Data INPUT (R0-R5,G0)	Negative	
9	RxIN0+	LVDS Differential Data INPUT (R0-R5,G0)	Positive	
10	GND	Ground		
11	RxIN1-	LVDS Differential Data INPUT (G1-G5,B0-B1)	Negative	
12	RxIN1+	LVDS Differential Data INPUT (Odd G1-G5,B0-B1)	Positive	
13	GND	Ground		
14	RxIN2-	LVDS Differential Data INPUT (B2-B5,Sync,DE)	Negative	
15	RxIN2+	LVDS Differential Data INPUT (B2-B5,Sync,DE)	Positive	
16	GND	Ground		
17	RxCLK-	LVDS Differential Data INPUT	Negative	
18	RxCLK+	LVDS Differential Data INPUT	Positive	
19	GND	Ground		
20	GND	Ground		

**Samsung Secret**

<b>Doc.No.</b>	LTN121AP02-001	<b>Rev.No</b>	04-A00-S-080709	<b>Page</b>	14 / 30
----------------	----------------	---------------	-----------------	-------------	---------

Approval

## 5.2 LVDS Interface : Transmitter DS90CF363 or Compatible

Pin No.	Name	RGB Signal	Pin No.	Name	RGB Signal
51	TxIN0	R0	14	TxIN14	G5
52	TxIN1	R1	15	TxIN15	B0
54	TxIN2	R2	19	TxIN18	B1
55	TxIN3	R3	20	TxIN19	B2
56	TxIN4	R4	22	TxIN20	B3
3	TxIN6	R5	23	TxIN21	B4
4	TxIN7	G0	24	TxIN22	B5
6	TxIN8	G1	27	TxIN24	Hsync
7	TxIN9	G2	28	TxIN25	Vsync
11	TxIN12	G3	30	TxIN26	DE
12	TxIN13	G4	31	TxCLKIN	Clock

### LVDS INTERFACE

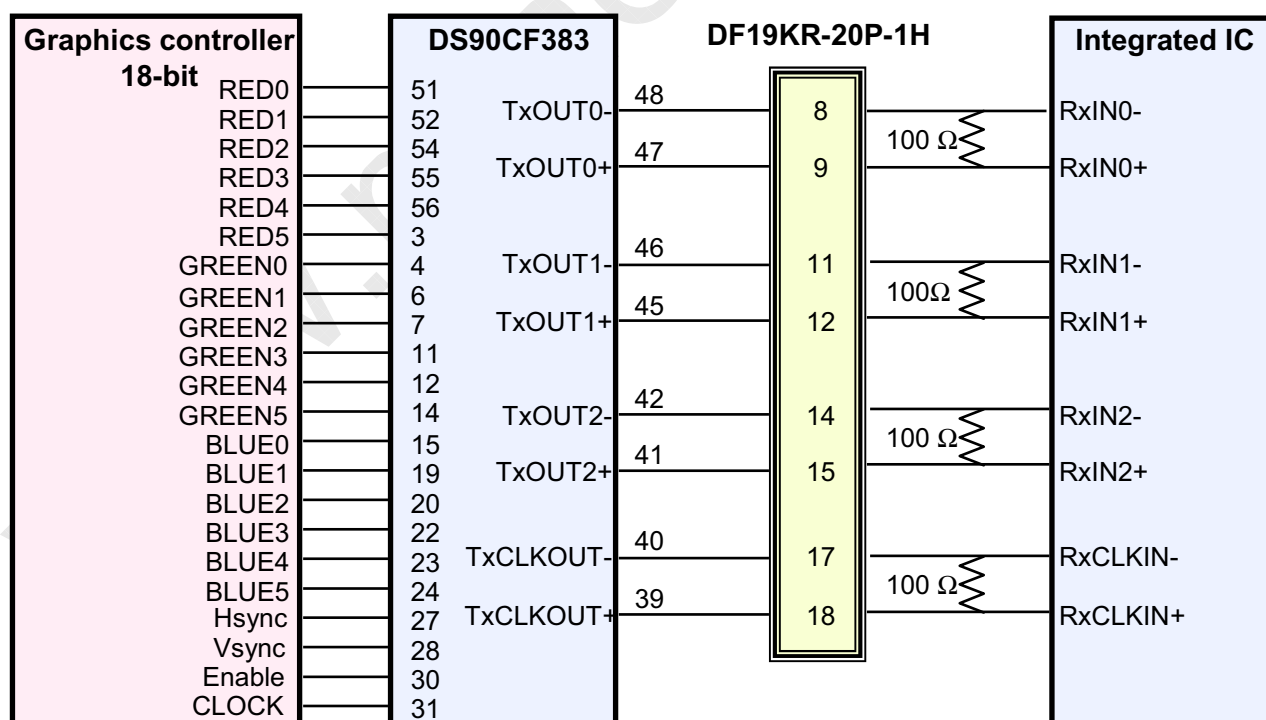

Note : The LCD Module uses a 100ohm resistor between positive and negative lines of each receiver input.

**Samsung Secret**

Doc.No.	LTN121AP02-001	Rev.No	04-A00-S-080709	Page	15 / 30
---------	----------------	--------	-----------------	------	---------

Approval

### 5.3 BACK LIGHT UNIT

Connector : JST BHSR - 02VS -1  
Mating Connector : SM02B-BHSS-1(JST)

Pin NO.	Symbol	Color	Function
1	HOT	Pink	High Voltage
2	COLD	Black	Low Voltage

### 5.4 Timing Diagrams of LVDS For Transmission

LVDS Receiver : Integrated T-CON

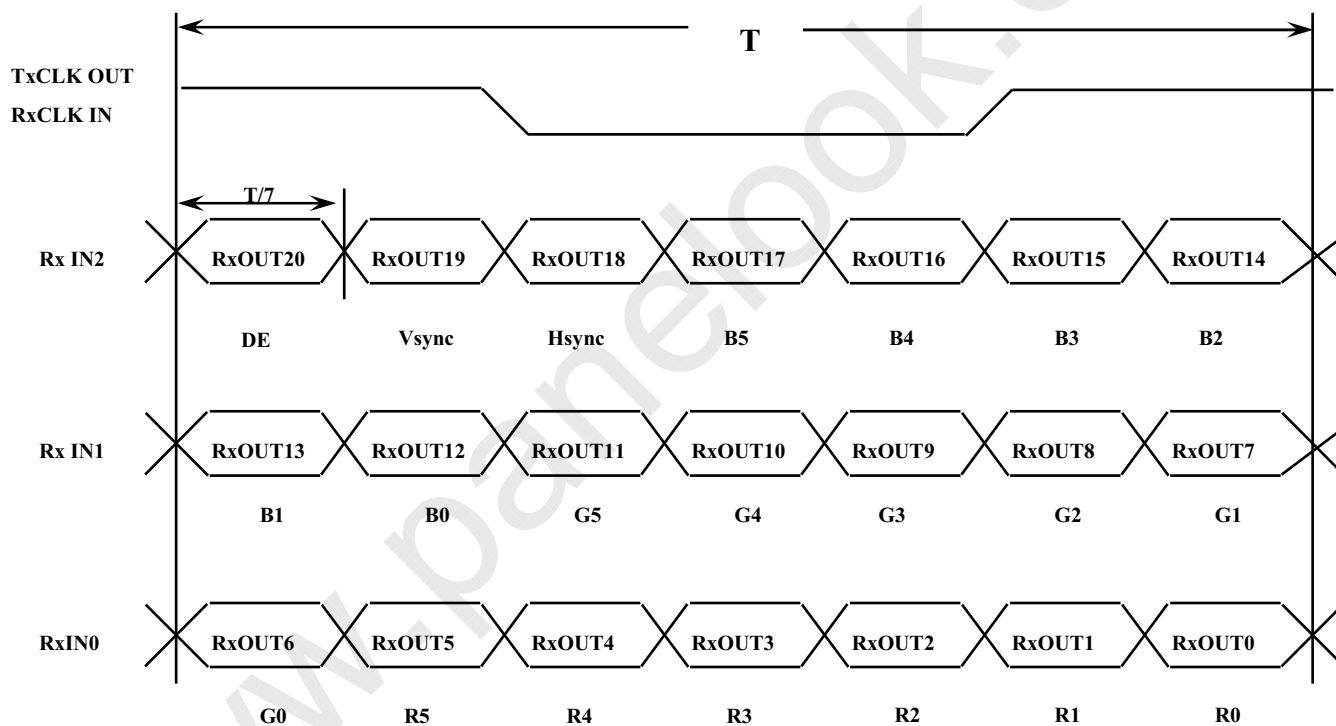

**Samsung Secret**



5.5 Input Signals, Basic Display Colors and Gray Scale of Each Color

Approval

COLOR	DISPLAY	DATA SIGNAL																GRAY SCALE LEVEL		
		RED					GREEN					BLUE								
		R0	R1	R2	R3	R4	R5	G0	G1	G2	G3	G4	G5	B0	B1	B2	B3		B4	B5
COLOR	BLACK	0	0	0	0	0	0	0	0	0	0	0	0	0	0	0	0	0	0	-
	BLUE	0	0	0	0	0	0	0	0	0	0	0	0	1	1	1	1	1	1	-
	GREEN	0	0	0	0	0	0	1	1	1	1	1	1	0	0	0	0	0	0	-
	CYAN	0	0	0	0	0	0	1	1	1	1	1	1	1	1	1	1	1	1	-
	RED	1	1	1	1	1	1	0	0	0	0	0	0	0	0	0	0	0	0	-
	MAGENTA	1	1	1	1	1	1	0	0	0	0	0	0	1	1	1	1	1	1	-
	YELLOW	1	1	1	1	1	1	1	1	1	1	1	1	0	0	0	0	0	0	-
	WHITE	1	1	1	1	1	1	1	1	1	1	1	1	1	1	1	1	1	1	-
GRAY SCALE OF RED	BLACK	0	0	0	0	0	0	0	0	0	0	0	0	0	0	0	0	0	0	R0
	DARK ↑	1	0	0	0	0	0	0	0	0	0	0	0	0	0	0	0	0	0	R1
		0	1	0	0	0	0	0	0	0	0	0	0	0	0	0	0	0	0	R2
		:	:	:	:	:	:	:	:	:	:	:	:	:	:	:	:	:	:	R3~R60
	:	:	:	:	:	:	:	:	:	:	:	:	:	:	:	:	:	:		
	LIGHT ↓	1	0	1	1	1	1	0	0	0	0	0	0	0	0	0	0	0	0	R61
		0	1	1	1	1	1	0	0	0	0	0	0	0	0	0	0	0	0	R62
RED	1	1	1	1	1	1	0	0	0	0	0	0	0	0	0	0	0	0	R63	
GRAY SCALE OF GREEN	BLACK	0	0	0	0	0	0	0	0	0	0	0	0	0	0	0	0	0	0	G0
	DARK ↑	0	0	0	0	0	0	1	0	0	0	0	0	0	0	0	0	0	0	G1
		0	0	0	0	0	0	0	1	0	0	0	0	0	0	0	0	0	0	G2
		:	:	:	:	:	:	:	:	:	:	:	:	:	:	:	:	:	:	G3~G60
	:	:	:	:	:	:	:	:	:	:	:	:	:	:	:	:	:	:		
	LIGHT ↓	0	0	0	0	0	0	1	0	1	1	1	1	0	0	0	0	0	0	G61
		0	0	0	0	0	0	0	1	1	1	1	1	0	0	0	0	0	0	G62
GREEN	0	0	0	0	0	0	1	1	1	1	1	1	0	0	0	0	0	0	G63	
GRAY SCALE OF BLUE	BLACK	0	0	0	0	0	0	0	0	0	0	0	0	0	0	0	0	0	0	B0
	DARK ↑	0	0	0	0	0	0	0	0	0	0	0	0	1	0	0	0	0	0	B1
		0	0	0	0	0	0	0	0	0	0	0	0	0	1	0	0	0	0	B2
		:	:	:	:	:	:	:	:	:	:	:	:	:	:	:	:	:	:	B3~B60
	:	:	:	:	:	:	:	:	:	:	:	:	:	:	:	:	:	:		
	LIGHT ↓	0	0	0	0	0	0	0	0	0	0	0	0	1	0	1	1	1	1	B61
		0	0	0	0	0	0	0	0	0	0	0	0	0	1	1	1	1	1	B62
GREEN	0	0	0	0	0	0	0	0	0	0	0	0	1	1	1	1	1	1	B63	

Note 1) Definition of gray :

Rn: Red gray, Gn: Green gray, Bn: Blue gray (n=gray level)

Note 2) Input signal: 0 =Low level voltage, 1=High level voltage

**Samsung Secret**

Approval

## 5.6 Pixel Format in the display

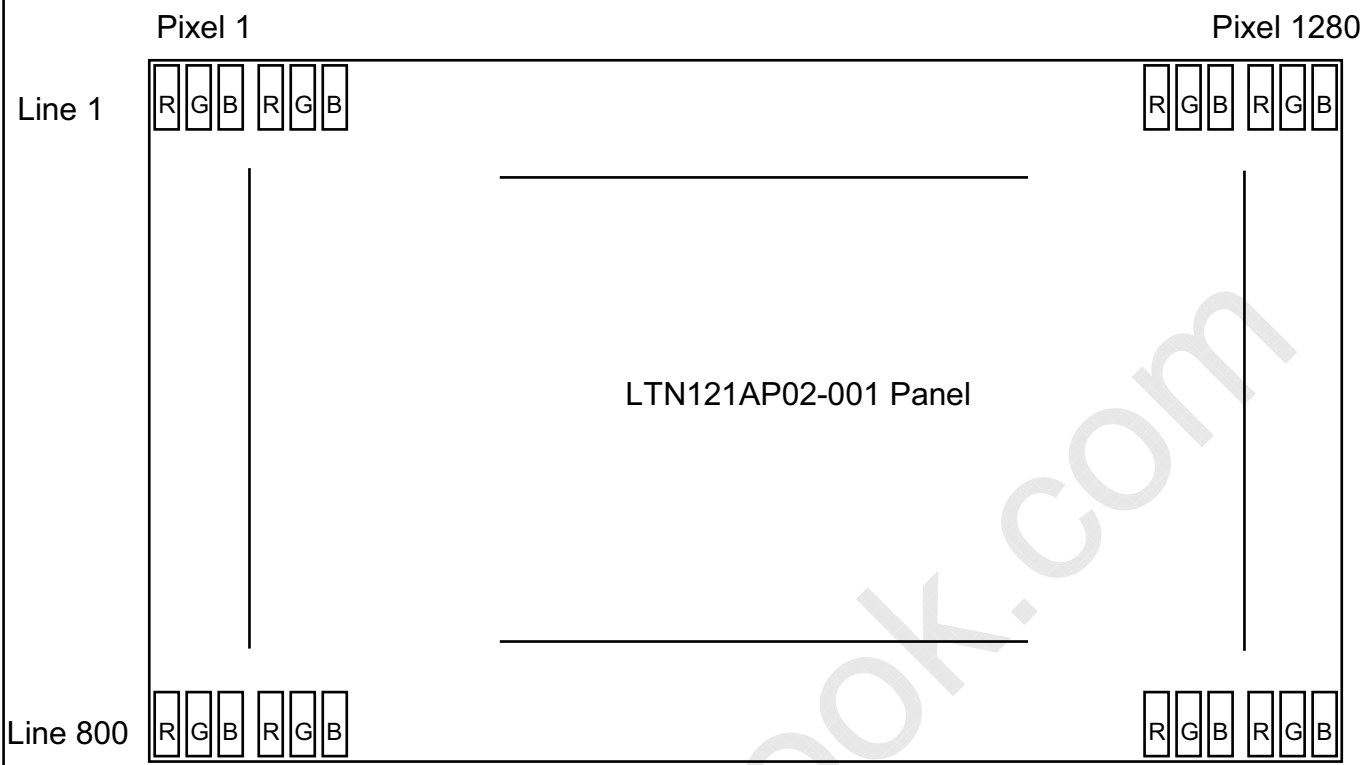

Samsung Secret

Doc.No.	LTN121AP02-001	Rev.No	04-A00-S-080709	Page	18 / 30
---------	----------------	--------	-----------------	------	---------

## 6. INTERFACE TIMING

Approval

### 6.1 Timing Parameters

Signal	Item	Symbol	Min.	Typ.	Max.	Unit	Note
Frame Frequency	Cycle	TV	804	816	828	Lines	
Vertical Active Display Term	Display Period	TVD	-	800	-	Lines	
One Line Scanning Time	Cycle	TH	1302	1408	1514	Clocks	
Horizontal Active Display Term	Display Period	THD	-	1280	-	Clocks	

### 6.2 Timing diagrams of interface signal

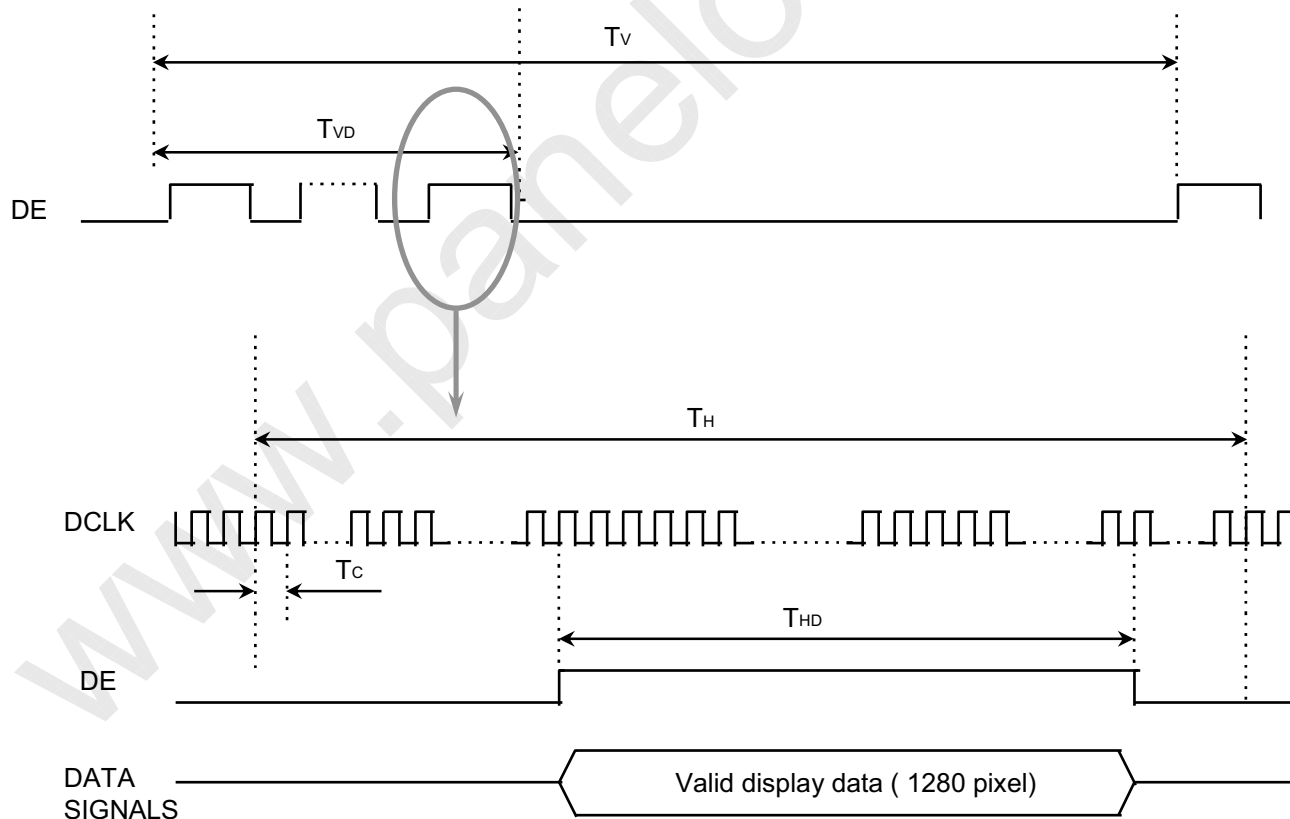

Samsung Secret

Approval

### 6.3 Power ON/OFF Sequence

: To prevent a latch-up or DC operation of the LCD module, the power on/off sequence shall be as shown below.

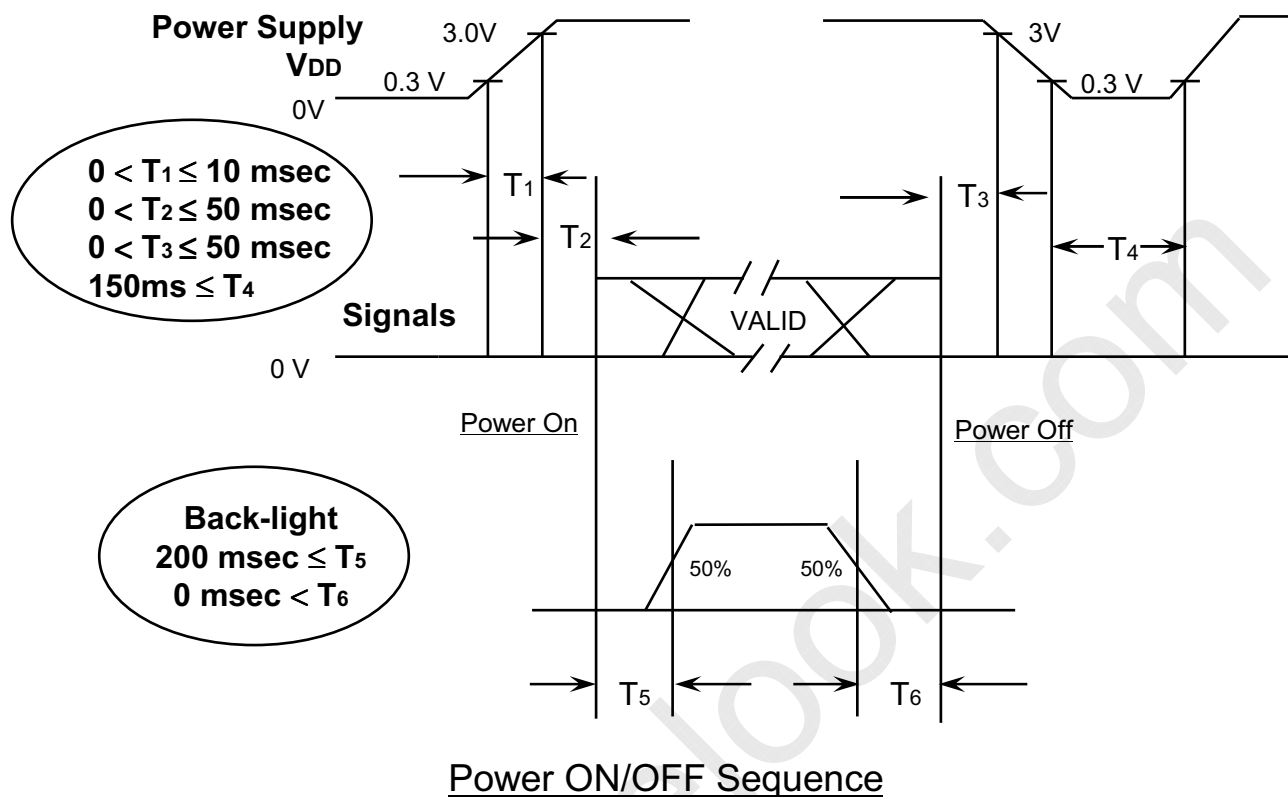

**Power ON/OFF Sequence**

- T1 : Vdd rising time from 0.3V to 3.0V
- T2 : The time from Vdd to valid data at power ON.
- T3 : The time from valid data off to Vdd off at power Off.
- T4 : Vdd off time for Windows restart
- T5 : The time from valid data to B/L enable at power ON.
- T6 : The time from valid data off to B/L disable at power Off.

#### NOTE.

- (1) The supply voltage of the external system for the module input should be the same as the definition of VDD.
- (2) Apply the lamp voltage within the LCD operation range. When the backlight turns on before the LCD operation or the LCD turns off before the backlight turns off, the display may momentarily become white.
- (3) In case of VDD = off level, please keep the level of input signals on the low or keep a high impedance.
- (4) T4 should be measured after the module has been fully discharged between power off and on period.
- (5) Interface signal shall not be kept at high impedance when the power is on.

**Samsung Secret**

Doc.No.	LTN121AP02-001	Rev.No	04-A00-S-080709	Page	20 / 30
---------	----------------	--------	-----------------	------	---------



### 7. Mechanical Outline Dimension

Approval

*[ Refer to the Next page ]*

www.panelook.com

**Samsung Secret**

<b>Doc.No.</b>	LTN121AP02-001	<b>Rev.No</b>	04-A00-S-080709	<b>Page</b>	21 / 30
----------------	----------------	---------------	-----------------	-------------	---------

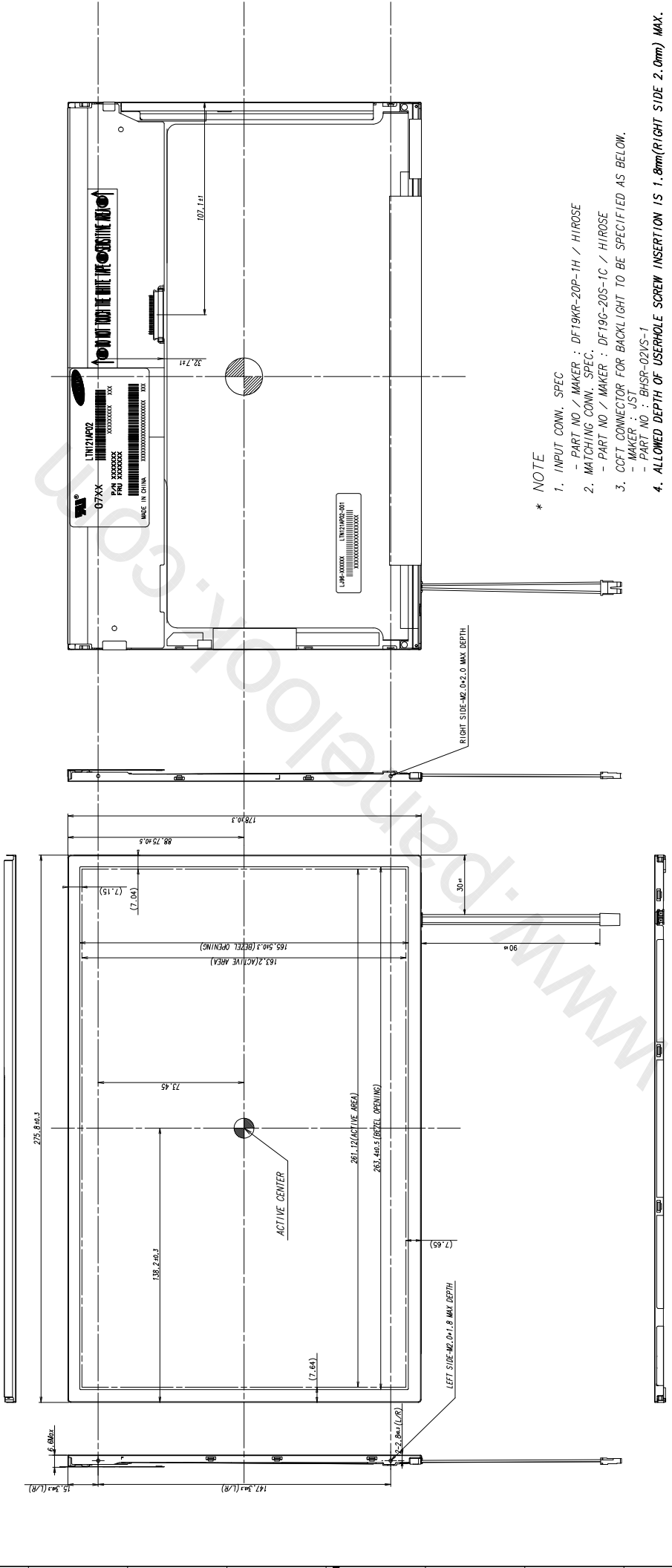
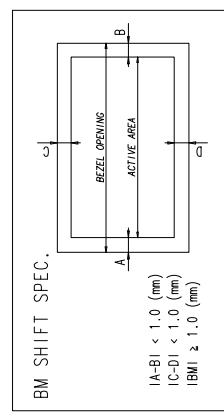
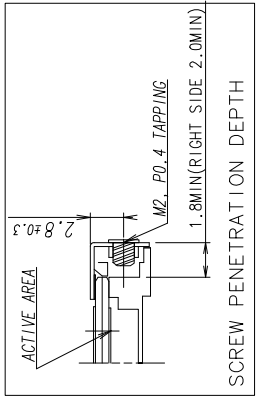
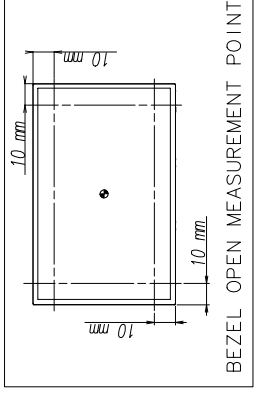

\* NOTE

1. INPUT CONN. SPEC  
- PART NO / MAKER : DF19KR-20P-1H / HIROSE
2. MATCHING CONN. SPEC.  
- PART NO / MAKER : DF19G-20S-1C / HIROSE
3. COFT CONNECTOR FOR BACKLIGHT TO BE SPECIFIED AS BELOW.  
- MAKER : JST  
- PART NO : BHSR-02/VS-1
4. ALLOWED DEPTH OF USERHOLE SCREW INSERTION IS 1.8mm(RIGHT SIDE 2.0mm) MAX.
5. MEASURING FORCE : 750±250gf-cm
6. MODULE WEIGHT : 300g MAX
7. MAXIMUM SCREW TORQUE : 2.5kgf-cm
8. CHASSIS TOP BEZEL OPEN SIZE MUST BE CHECKED AT MEASUREMENT POINT

REV.	DATE	DESCRIPTION OF REVISION	CHK'D BY
1		DRAWN BY DES'D BY CHK'D BY APP'D BY	
SCALE	1/1	J.E. 100	S.H. LEE
TOLERANCE	0.01/2X	0.01/2X	0.01/2X
REV.	NO	SPEC.	NO
SAMSUNG ELECTRONICS			
MODEL NAME		LTM21P02-001	
PART/SHEET NAME		OUTLINE DIMENSION	
SHEET 1/1		VER. 000	

## 8. PACKING

Approval

### 1. CARTON(Internal Package)

#### (1) Packing Form

Corrugated Cardboard box and Corrupad form as shock absorber

#### (2) Packing Method

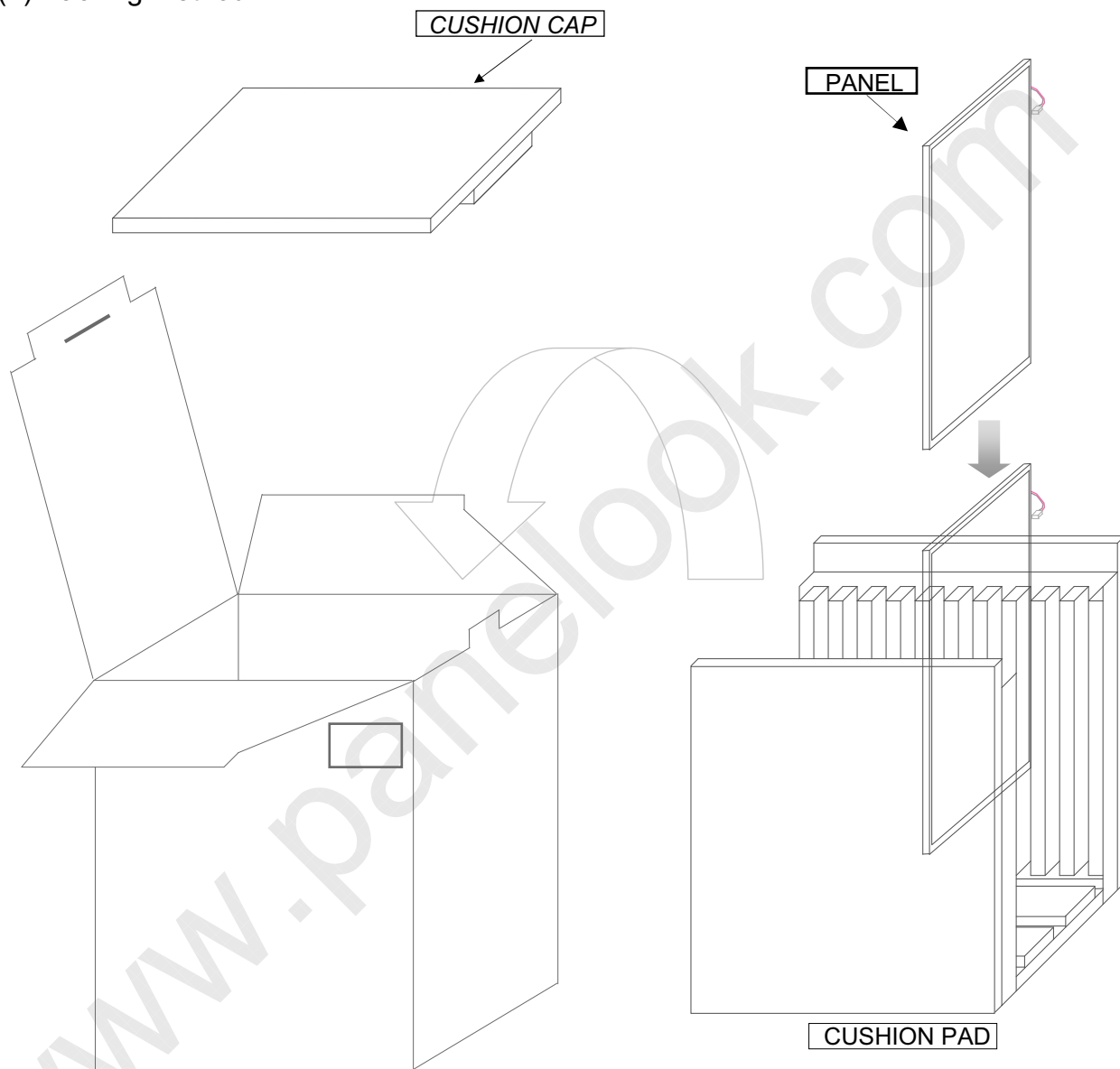

PACKING CASE

- Note 1) Total Weight : Approximately 4.0 kg  
 2) Acceptance number of piling : 10 sets  
 3) Carton size : 295(W) × 280(D) × 364(H)  
 4) MAX accumulation quantity : 5 cartons

**Samsung Secret**

Doc.No.	LTN121AP02-001	Rev.No	04-A00-S-080709	Page	23 / 30
---------	----------------	--------	-----------------	------	---------

Approval

No	Part name	Quantity
1	Static electric protective sack	10
2	Packing case (Inner box) included shock absorber	1 set
3	Pictorial marking	2 pcs
4	Carton	1 set

**Samsung Secret**

<b>Doc.No.</b>	LTN121AP02-001	<b>Rev.No</b>	04-A00-S-080709	<b>Page</b>	24 / 30
----------------	----------------	---------------	-----------------	-------------	---------



Approval

### 9. Product Markings and Others

A nameplate bearing followed by is affixed to a shipped product at the specified location on each product.

- (1)Parts number : LTN121AP02-001
- (2)Revision : Three letters
- (3)Control code : One letter
- (4)Lot number : X X X X XXX XX X 001

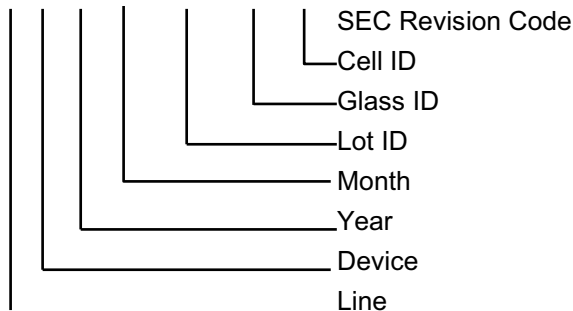

#### (5) Product Label Definition - SESL

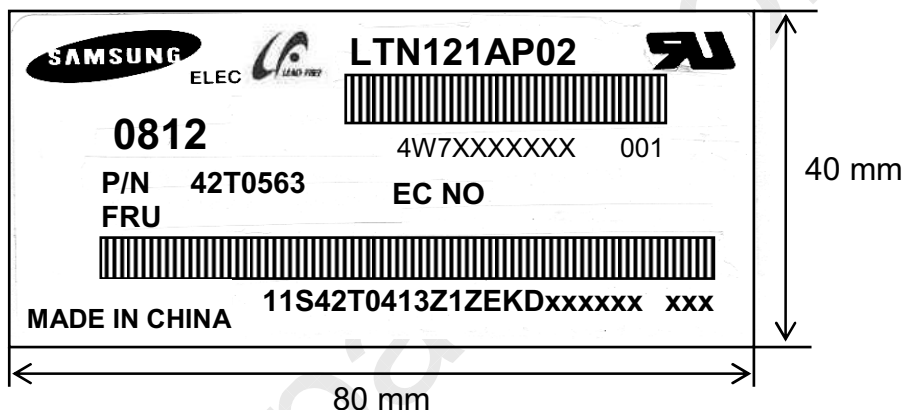

- TFT-LCD Product name : LTN121AP02
- Lot number : 4W7XXXXXXXXX
- Revision Code : 001
- Inspected work week : 0812(2008 Year, the 12<sup>th</sup> week)
- P/N : Lenovo Part Number (42T0563)
- EC NO : Engineering Change Number (Blank)
- FRU : Field Replaceable Unit Part Number (Blank)
- Header Code : 1ZEKD
- Lenovo Lot No : 11S42T0563Z1ZEKD XXXXXX XXX

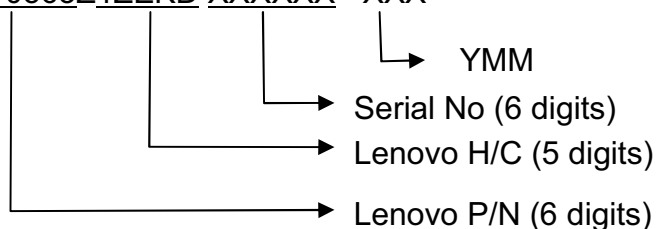

**Samsung Secret**

<b>Doc.No.</b>	LTN121AP02-001	<b>Rev.No</b>	04-A00-S-080709	<b>Page</b>	25 / 30
----------------	----------------	---------------	-----------------	-------------	---------

Approval

## 10. GENERAL PRECAUTIONS

### 1. Handling

- (a) When the module is assembled, It should be attached to the system firmly using selected mounting holes. Be careful not to twist and bend the modules.
- (b) Refrain from strong mechanical shock and / or any force to the module. In addition to damage, this may cause improper operation or damage to the module and CCFT backlight.
- (c) Note that polarizers are very fragile and could be easily damaged. Do not press or scratch the surface harder than a HB pencil lead.
- (d) Wipe off water droplets or oil immediately. If you leave the droplets for a long time, Staining and discoloration may occur.
- (e) If the surface of the polarizer is dirty, clean it using some absorbent cotton or soft cloth.
- (f) The desirable cleaners are water, IPA (Isoprophyl Alcohol) or Hexane. Do not use Ketone type materials(ex. Acetone), Ethyl alcohol, Toluene, Ethyl acid or Methyl chloride. It might permanent damage to the polarizer due to chemical reaction.
- (g) If the liquid crystal material leaks from the panel, it should be kept away from the eyes or mouth. In case of contact with hands, legs or clothes, it must be washed away thoroughly with soap.
- (h) Protect the module from static, it may cause damage to the C-MOS Gate Array IC.
- (i) Use fingerstalls with soft gloves in order to keep display clean during the incoming inspection and assembly process.
- (j) Do not disassemble the module.
- (k) Do not pull or fold the lamp wire.
- (l) Do not adjust the variable resistor which is located on the back side.
- (m) Protection film for polarizer on the module shall be slowly peeled off just before use so that the electrostatic charge can be minimized.
- (n) Pins of I/F connector shall not be touched directly with bare hands.

**Samsung Secret**

<b>Doc.No.</b>	LTN121AP02-001	<b>Rev.No</b>	04-A00-S-080709	<b>Page</b>	26 / 30
----------------	----------------	---------------	-----------------	-------------	---------

Approval

## 2. STORAGE

- (a) Do not leave the module in high temperature, and high humidity for a long time. It is highly recommended to store the module with temperature from 0 to 35°C and relative humidity of less than 70%.
- (b) Do not store the TFT-LCD module in direct sunlight.
- (c) The module shall be stored in a dark place. It is prohibited to apply sunlight or fluorescent light during the store.

## 3. OPERATION

- (a) Do not connect, disconnect the module in the “ Power On” condition.
- (b) Power supply should always be turned on/off by following item 6.3 “ Power on/off sequence “.
- (c) Module has high frequency circuits. Sufficient suppression to the electromagnetic interference shall be done by system manufacturers. Grounding and shielding methods may be important to minimize the interference.
- (d) The cable between the backlight connector and its inverter power supply shall be a minimized length and be connected directly . The longer cable between the backlight and the inverter may cause lower luminance of lamp(CCFT) and may require higher startup voltage(Vs).

## 4. OTHERS

- (a) Ultra-violet ray filter is necessary for outdoor operation.
- (b) Avoid condensation of water. It may result in improper operation or disconnection of electrode.
- (c) Do not exceed the absolute maximum rating value. ( the supply voltage variation, input voltage variation, variation in part contents and environmental temperature, so on) Otherwise the module may be damaged.
- (d) If the module displays the same pattern continuously for a long period of time, it can be the situation when the image “sticks” to the screen.
- (e) This module has its circuitry PCB's on the rear side and should be handled carefully in order not to be stressed.

**Samsung Secret**

<b>Doc.No.</b>	LTN121AP02-001	<b>Rev.No</b>	04-A00-S-080709	<b>Page</b>	27 / 30
----------------	----------------	---------------	-----------------	-------------	---------

# 11. EDID

Approval

Address (HEX)	FUNCTION	Value	BIN	DEC	ASCII or Data	Notes
		HEX				
00	Header	00	00000000	0		EDID Header
01		FF	11111111	255		
02		FF	11111111	255		
03		FF	11111111	255		
04		FF	11111111	255		
05		FF	11111111	255		
06		FF	11111111	255		
07		00	00000000	0		
08	ID Manufacturer Name	30	00110000	48	L E N	3 character ID
09		AE	10101110	174		"LEN" as an end-customer
0A	ID Product Code	10	00010000	16		#WXGA
0B		40	01000000	64		
0C	32-bit serial no.	00	00000000	0		
0D		00	00000000	0		
0E		00	00000000	0		
0F		00	00000000	0		
10	Week of manufacture	2D	00101101	45		
11	Year of manufacture	12	00010010	18	2008	2007
12	EDID Structure Ver.	01	00000001	1	1	EDID Ver. 1.0
13	EDID revision #	03	00000011	3	3	EDID Rev. 3
14	Video input definition	80	10000000	128		
15	Max H image size	1A	00011010	26	26	26 cm(approx)
16	Max V image size	10	00010000	16	16	16 cm(approx)
17	Display Gamma	78	01111000	120	2.2	Gamma 2.2
18	Feature support	EA	11101010	234		
19	Red/green low bits	85	10000101	133		10000111
1A	Blue/white low bits	C5	11000101	197		11111110
1B	Red x/ high bits	94	10010100	148	0.580	Red x 0.569= 1001010010
1C	Red y	57	01010111	87	0.340	Red y 0.332= 0101011100
1D	Green x	4F	01001111	79	0.310	Green x 0.312= 0100111101
1E	Green y	8A	10001010	138	0.540	Green y 0.544= 1000110011
1F	Blue x	27	00100111	39	0.155	Blue x 0.149= 0010011111
20	Blue y	20	00100000	32	0.125	Blue y 0.132= 0010011111
21	White x	50	01010000	80	0.313	White x 0.313= 0101000001
22	White y	54	01010100	84	0.329	White y 0.329= 0101010001
23	Established timing 1	00	00000000	0		
24	Established timing 2	00	00000000	0		
25	Established timing 3	00	00000000	0		
26	Standard timing #1	01	00000001	1		not used
27		01	00000001	1		
28	Standard timing #2	01	00000001	1		not used
29		01	00000001	1		
2A	Standard timing #3	01	00000001	1		not used
2B		01	00000001	1		
2C	Standard timing #4	01	00000001	1		not used
2D		01	00000001	1		
2E	Standard timing #5	01	00000001	1		not used
2F		01	00000001	1		
30	Standard timing #6	01	00000001	1		not used
31		01	00000001	1		
32	Standard timing #7	01	00000001	1		not used
33		01	00000001	1		
34	Standard timing #8	01	00000001	1		not used
35		01	00000001	1		

**Samsung Secret**

Approval

36	Detailed timing/monitor descriptor #1	FD	11111101	253	76.77	Main clock= 76.77 MHz (@60Hz)	
37		1D	00011101	29			
38		00	00000000	0	1280		Hor active=640*2 pixels
39		20	00100000	32	288		Hor blanking=288 pixels
3A		51	01010001	81			4bit : 4bit
3B		20	00100000	32	800		Vertical active=800 lines
3C		10	00010000	16	16		Vertical blanking=16 lines
3D		30	00110000	48			4bit : 4bit
3E		34	00110100	52	52		Hor sync. Offset=52 pixels
3F		40	01000000	64	64		H sync. Width=64 pixels
40		33	00110011	51	3		V sync. Offset=3 lines
					3		V sync. Width=3 lines
41		00	00000000	0			2bit : 2bit :2bit :2bit
42		05	00000101	5	261		H image size= 261 mm(approx)
43		A3	10100011	163	163		V image size = 163 mm(approx)
44		10	00010000	16			
45		00	00000000	0			No Horizontal Border
46	00	00000000	0		No Vertical Border		
47	19	00011001	25				
48	Detailed timing/monitor descriptor #2	FD	11111101	253	76.77	Main clock= 76.77MHz (@60Hz)	
49		1D	00011101	29			
4A		00	00000000	0	1280		Hor active=640*2 pixels
4B		20	00100000	32	288		Hor blanking=288 pixels
4C		51	01010001	81			4bit : 4bit
4D		20	00100000	32	800		Vertical active=800 lines
4E		10	00010000	16	16		Vertical blanking=16 lines
4F		30	00110000	48			4bit : 4bit
50		34	00110100	52	52		Hor sync. Offset=52 pixels
51		40	01000000	64	64		H sync. Width=64 pixels
52		33	00110011	51	3		V sync. Offset=3 lines
					3		V sync. Width=3 lines
53		00	00000000	0			2bit : 2bit :2bit :2bit
54		05	00000101	5	261		H image size= 261 mm(approx)
55		A3	10100011	163	163		V image size = 163 mm(approx)
56		10	00010000	16			
57		00	00000000	0			No Horizontal Border
58	00	00000000	0		No Vertical Border		
59	19	00011001	25				
5A	descriptor #3	00	00000000	0		Manufacturer Specified (Timing)	
5B		00	00000000	0			
5C		00	00000000	0			
5D		0F	00001111	15			
5E		00	00000000	0			
5F		81	10000001	129		(Horizontal active pixel /8)-31	
60		0A	00001010	10		Image Aspect Ratio(16:10)	
61		3C	00111100	60		Low Refresh Rate #1(50Hz)	
62		81	10000001	129		(Horizontal active pixel /8)-31	
63		0A	00001010	10		Image Aspect Ratio(16:10)	
64		3C	00111100	60		Low Refresh Rate #1(40Hz)	
65		15	00010101	21		Brightness(1/10nit) = 200/10nit	
66	00	00000000	0		Feature flag(TN mode)		
67	00	00000000	0				
68	4C	01001100	76				
69	A3	10100011	163		supplier ID "SEC"		
6A	57	01010111	87	[A]	Product code "AP"		
6B	31	00110001	49	[P]	(Hex, LSB first)		

Samsung Secret

Approval

6C	Detailed timing/monitor descriptor #4	00	00000000	0		Monitor Name Tag (ASCII)
6D		00	00000000	0		
6E		00	00000000	0		
6F		FE	11111110	254		
70		00	00000000	0		
71		4C	01001100	76	[L]	
72		54	01010100	84	[T]	
73		4E	01001110	78	[N]	
74		31	00110001	49	[1]	
75		32	00110010	50	[2]	
76		31	00110001	49	[1]	
77		41	01000001	65	[A]	
78		50	01010000	80	[P]	
79		30	00110000	48	[0]	
7A		32	00110010	50	[2]	
7B	30	00110000	48	[0]		
7C	30	00110000	48	[0]		
7D	31	00110001	49	[1]		
7E	Extension Flag	00	00000000	0		
7F	Checksum	8D	10001101	141		

Samsung Secret

Doc.No.	LTN121AP02-001	Rev.No	04-A00-S-080709	Page	30 / 30
---------	----------------	--------	-----------------	------	---------