

SAMSUNG**ELECTRONICS**

Preliminary



TO : General
 DATE : July.10 2009

SAMSUNG TFT-LCD**MODEL NO. : LTN121AT06-L02**

NOTE :

- Extension code [**L02**]
- Surface type [**Glare**]

The information described in this SPEC is preliminary and can be changed without prior notice.

APPROVED BY : **Je-Hwan Oh**

PREPARED BY : **TCS Team , Application Engineering Part**

SAMSUNG ELECTRONICS CO., LTD.**Samsung Secret**

Doc.No.	LTN121AT06-L02	Rev.No	04-P00-G-090710	Page	1 / 27
----------------	----------------	---------------	-----------------	-------------	--------

CONTENTS

Preliminary

Revision History	----- (3)
General Description	----- (4)
1. Absolute Maximum Ratings	----- (5)
1.1 Absolute Ratings of environment	
1.2 Electrical Absolute Ratings	
2. Optical Characteristics	----- (7)
3. Electrical Characteristics	----- (10)
3.1 TFT LCD Module	
3.2 Backlight Unit	
3.3 LED Driver	
4. Block Diagram	----- (13)
4.1 TFT LCD Module	
5. Input Terminal Pin Assignment	----- (14)
5.1 Input Signal & Power	
5.2 LVDS Interface	
5.3 Timing Diagrams of LVDS For Transmitting	
5.4 Input Signals, Basic Display Colors and Gray Scale of Each Color.	
5.5 Pixel format	
5.6 LED Driver Connector & Pin Assignment	
6. Interface Timing	----- (19)
6.1 Timing Parameters	
6.2 Timing Diagrams of interface Signal	
6.3 Power ON/OFF Sequence	
7. Outline Dimension	----- (21)
8. Packing	----- (23)
9. Markings & Others	----- (24)
10. General Precautions	----- (26)
11. EDID	----- (28)

Samsung Secret

REVISION HISTORY

Preliminary

Date	Revision No.	Page	Summary
July.10. 2009	P00	All	LTN121AT06-L02 model spec was issued first. (This model will be provided through Line 6)

Samsung Secret

Doc.No.	LTN121AT06-L02	Rev.No	04-P00-G-090710	Page	3 / 27
----------------	----------------	---------------	-----------------	-------------	--------

Preliminary

GENERAL DESCRIPTION

DESCRIPTION

LTN121AT06 is a color active matrix TFT (Thin Film Transistor) liquid crystal display (LCD) that uses amorphous silicon TFT as switching devices. This model is composed of a TFT LCD panel, a driver circuit and a backlight unit. The resolution of a 12.1" contains 1280 x 800 pixels and can display up to 262,144 colors. 6 O'clock direction is the optimum viewing angle.

FEATURES

- High contrast ratio
- WXGA (1280 x 800 pixels) resolution
- Low power consumption
- Fast Response
- LED Back Light with embedded LED Driver
- DE (Data enable) only mode
- 3.3V LVDS Interface
- Onboard EEDID chip
- Green product (RoHS compliant)

APPLICATIONS

- Notebook PC
- If the usage of this product is not for PC application, but for others, please contact SEC

GENERAL INFORMATION

Item	Specification	Unit	Note
Display area	261.12(H) x 163.2(V) (12.1" wide diagonal)	mm	
Driver element	a-Si TFT active matrix		
Display colors	262,144		
Number of pixel	1280 x 800	pixel	
Pixel arrangement	RGB vertical stripe		
Pixel pitch	0.204(H) x 0.204(V) (TYP.)	mm	
Display Mode	Normally white		
Surface treatment	Haze 0, Hard-Coating 3H		Glare

Samsung Secret

Preliminary

Mechanical Information

Item		Min.	Typ.	Max.	Unit	Note
Module size	Horizontal (H)	275.3	275.8	276.3	mm	
	Vertical (V)	177.6	178.1	178.6	mm	
	Depth (D)	-	5.2	5.5	mm	(1)
Weight		-	278	295	g	

Note (1) Measurement condition of outline dimension
 . Equipment : Bernier Calipers
 . Push Force : 500g · f (minimum)

1. ABSOLUTE MAXIMUM RATINGS

1.1 ENVIRONMENTAL ABSOLUTE RATINGS

Item	Symbol	Min.	Max.	Unit	Note
Storage temperate	TSTG	-20	60	°C	(1)
Operating temperate (Temperature of glass surface)	TOPR	0	50	°C	(1)
Shock (non-operating)	Snop	-	240	G	(2),(4)
Vibration (non-operating)	Vnop	-	2.41	G	(3),(4)

Note (1) Temperature and relative humidity range are shown in the figure below.

95 % RH Max. ($40\text{ }^{\circ}\text{C} \geq T_a$)

Maximum wet - bulb temperature at $39\text{ }^{\circ}\text{C}$ or less. ($T_a > 40\text{ }^{\circ}\text{C}$) No condensation

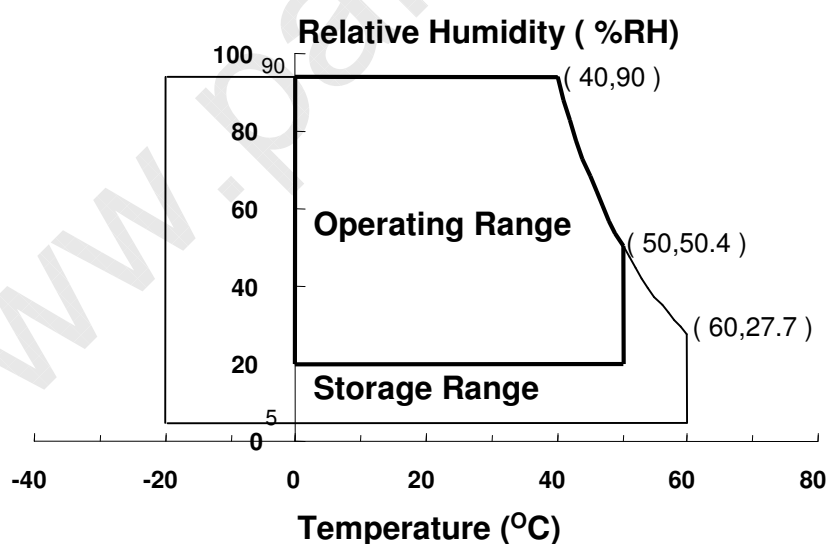

(2) 2ms, half sine wave, one time for $\pm X, \pm Y, \pm Z$.

(3) 5 - 500 Hz, random vibration, 30min for X, Y, Z.

(4) At testing Vibration and Shock, the fixture in holding the Module to be tested have to be hard and rigid enough so that the Module would not be twisted or bent by the fixture.

Samsung Secret

Preliminary

1.2 ELECTRICAL ABSOLUTE RATINGS

(1) TFT LCD MODULE

 $V_{DD} = 3.3V, V_{SS} = GND = 0V$

Item	Symbol	Min.	Max.	Unit	Note
Power Supply Voltage	V_{DD}	$V_{DD} - 0.3$	$V_{DD} + 0.3$	V	(1)
Logic Input Voltage	V_{IN}	$V_{DD} - 0.3$	$V_{DD} + 0.3$	V	(1)

Note (1) Within T_a (25 ± 2 °C)

Samsung Secret

Preliminary

2. OPTICAL CHARACTERISTICS

The following items are measured under stable conditions. The optical characteristics should be measured in a dark room or equivalent state with the methods shown in Note (5).
Measuring equipment : TOPCON SR-3

* Ta = 25 ± 2 °C, V_{DD}=3.3V, fv= 60Hz, fd_{CLK} = 69.3MHz, IF = 18.0 mA

Item	Symbol	Condition	Min.	Typ.	Max	Unit	Note
Contrast Ratio (5 Points)	CR		400	500	-	-	(1), (2), (5)
Response Time at Ta (Rising + Falling)	T _{RT}		-	25	35	msec	(1), (3)
Average Luminance of White (5 Points)	Y _{L,AVE}		170	200	-	cd/m ²	IF=18.0mA (1), (4)
Color Chromaticity (CIE)	Red	R _X	0.536	0.566	0.596	-	(1), (5) SR-3
		R _Y	0.307	0.337	0.367		
	Green	G _X	0.321	0.351	0.381		
		G _Y	0.530	0.560	0.590		
	Blue	B _X	0.120	0.150	0.180		
		B _Y	0.064	0.094	0.124		
	White	W _X	0.283	0.313	0.343		
		W _Y	0.299	0.329	0.359		
Viewing Angle	Hor.	θ _L	30	45	CR ≥ 10 At center	Degrees	(1), (5) SR-3
		θ _H	30	45			
	Ver.	φ _H	10	20			
		φ _L	20	30			
13 Points White Variation	δ _L	-	1.4	1.6	-	(6)	

Samsung Secret

Doc.No.

LTN121AT06-L02

Rev.No

04-P00-G-090710

Page

7 / 27

Preliminary

Note 1) Definition of Viewing Angle : Viewing angle range($10 \leq C/R$)

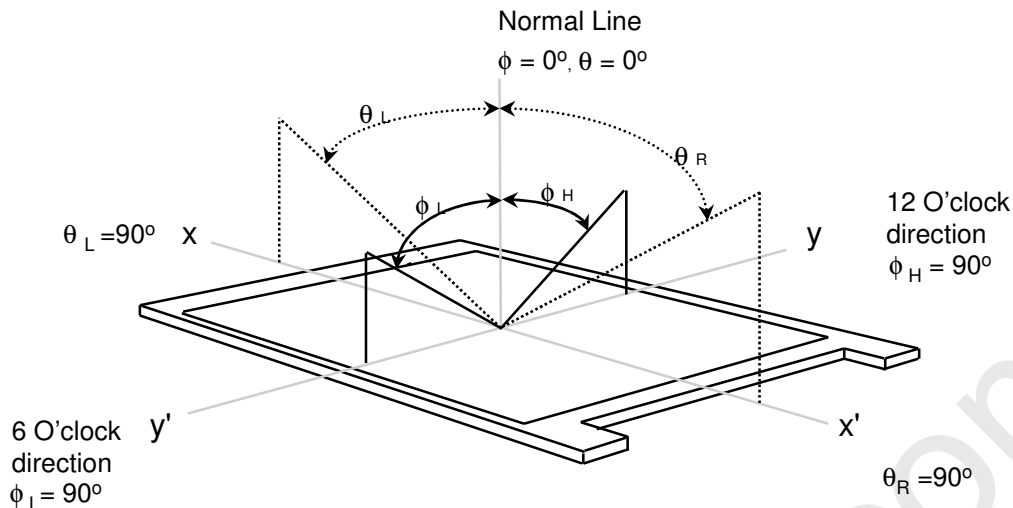

Note 2) Definition of Contrast Ratio (CR) : Ratio of gray max (Gmax) ,gray min (Gmin) at 5 points(4, 5, 7, 9, 10)

$$CR = \frac{CR(4) + CR(5) + CR(7) + CR(9) + CR(10)}{5}$$

Points : (4) , (5) , (7) , (9) , (10) at the figure of Note (6).

Note 3) Definition of Response time :

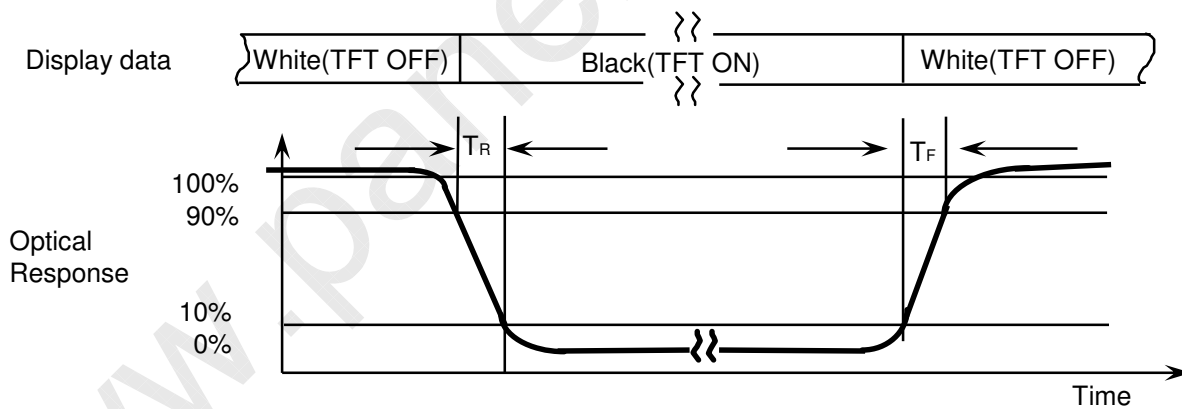

Note 4) Definition of Average Luminance of White : measure the luminance of white at 5 points.

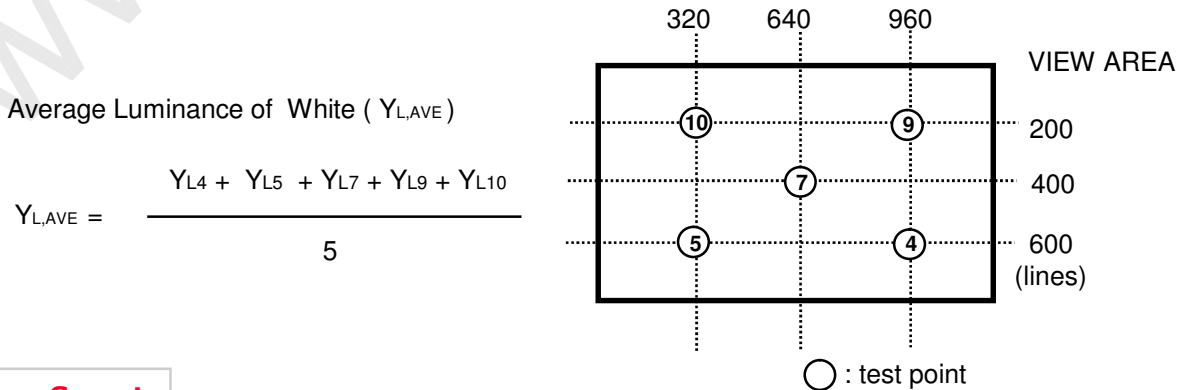

Samsung Secret

Preliminary

Note 5) After stabilizing and leaving the panel alone at a given temperature for 30 min , the measurement should be executed. Measurement should be executed in a stable, windless, and dark room. 30 min after lighting the backlight. This should be measured in the center of screen.
 IF current : 19.0mA
 Environment condition : Ta = 25 ± 2 °C

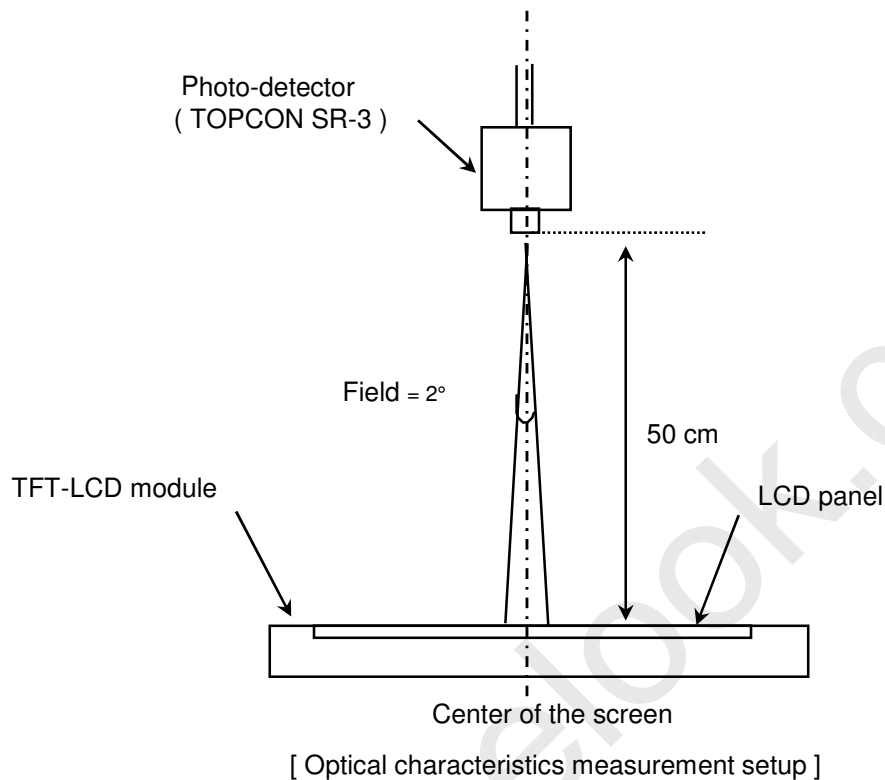

Note 6) Definition of 13 points white variation (δL), CR variation(C_{VER}) [① ~ ⑬]

$$\delta L = \frac{\text{Maximum luminance of 13 points}}{\text{Minimum luminance of 13 points}}$$

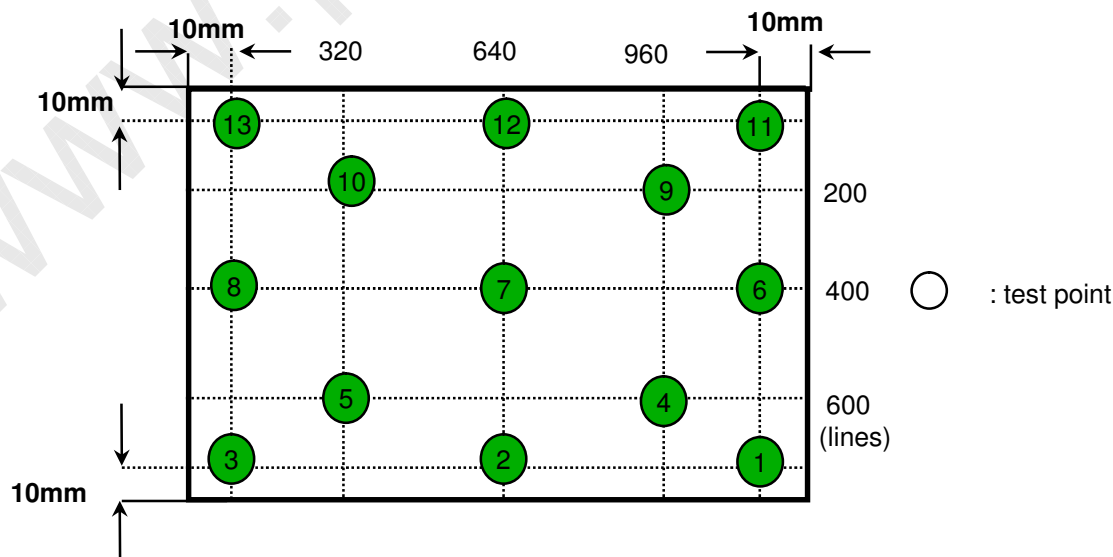

Samsung Secret

Doc.No.	LTN121AT06-L02	Rev.No	04-P00-G-090710	Page	9 / 27
---------	----------------	--------	-----------------	------	--------

3. ELECTRICAL CHARACTERISTICS

Preliminary

3.1 TFT LCD MODULE

Ta= 25 ± 2°C

Item	Symbol	Min.	Typ.	Max.	Unit	Note	
Voltage of Power Supply	V _{DD}	3.0	3.3	3.6	V		
Differential Input Voltage for LVDS Receiver Threshold	High	V _{IH}	-	-	+100	mV	V _{CM} = +1.2V
	Low	V _{IL}	-100	-	-	mV	
Vsync Frequency	f _v	-	60	-	Hz		
Hsync Frequency	f _H	-	51.2	-	KHz		
Main Frequency	f _{DCLK}	67.2	69.3	70.6	MHz		
Rush Current	I _{RUSH}	-	-	1.5	A	(4)	
Current of Power Supply	White	I _{DD}	-	220	-	mA	(2),(3)*a
	Mosaic		-	240	-	mA	(2),(3)*b
	V. stripe		-	280	320	mA	(2),(3)*c

Note (1) Display data pins and timing signal pins should be connected. (GND = 0V)

(2) f_v = 60Hz, f_{DCLK} = 69.3MHz, V_{DD} = 3.3V, DC Current.

(3) Power dissipation pattern

*a) White Pattern

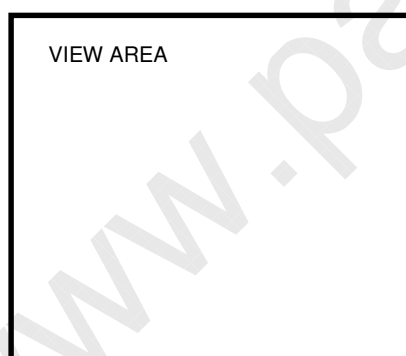

*b) Mosaic Pattern

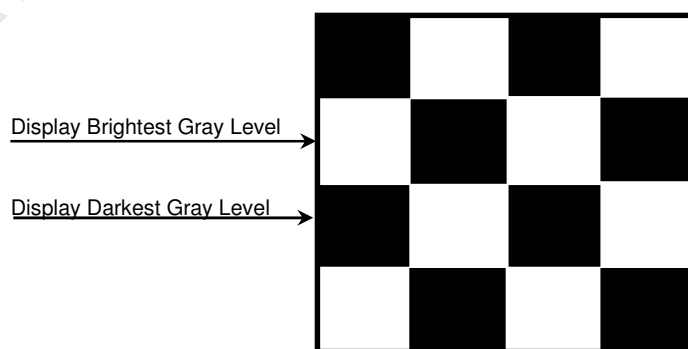

Samsung Secret

Preliminary

*c) 1dot Vertical stripe pattern

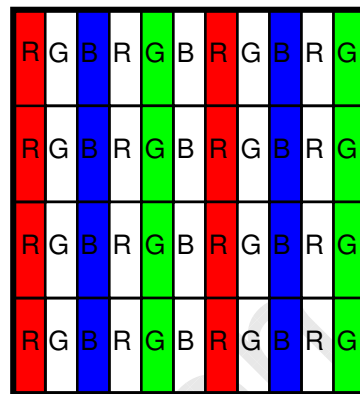
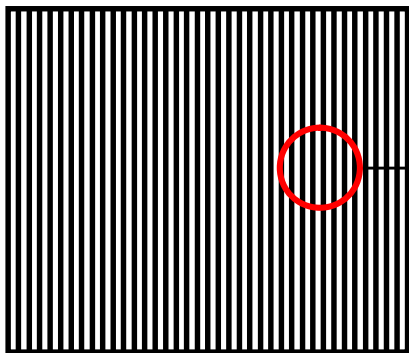

4) Rush current measurement condition

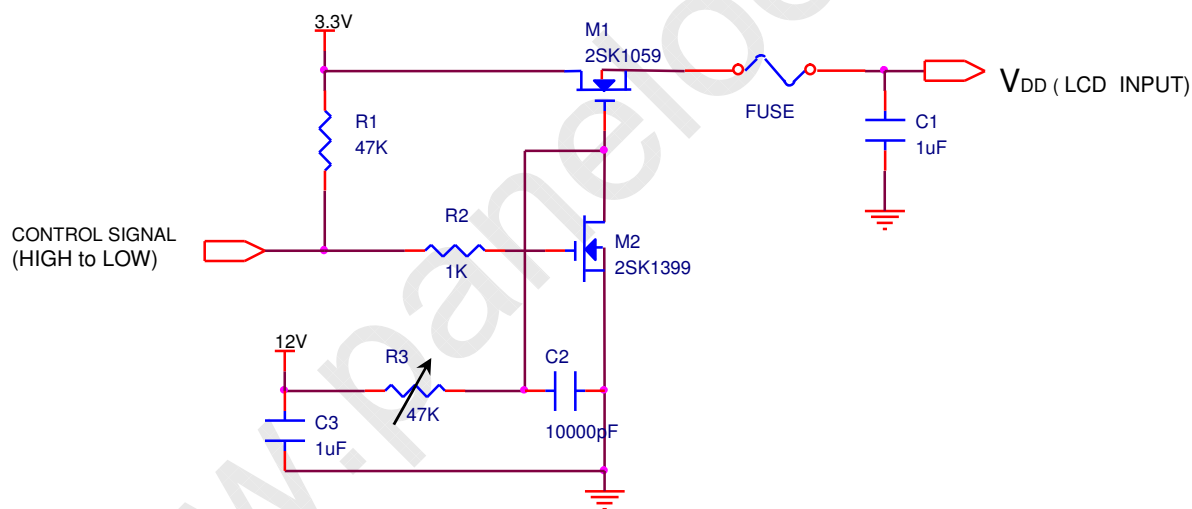

V_{DD} rising time is 470us

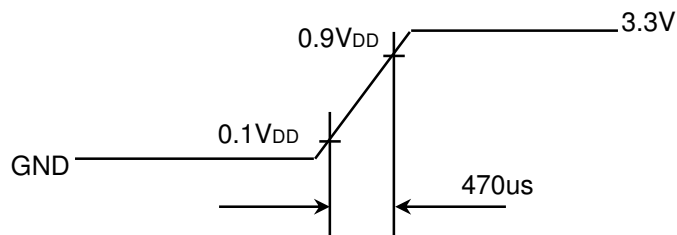

Samsung Secret

Doc.No.	LTN121AT06-L02	Rev.No	04-P00-G-090710	Page	11 / 27
---------	----------------	--------	-----------------	------	---------

Preliminary

3.2 BACK-LIGHT UNIT

Ta= 25 ± 2 °C

Item	Symbol	Min.	Typ.	Max.	Unit	Note
LED Forward Current	IF	-	18	-	mA	
LED Forward Voltage	VF	-	3.2	-	V	
LED Array Voltage	VP	-	25.6	-	V	VF X 8 LEDs
Power Consumption	P	-	2.3	-	W	IF X VF X 40LEDs
Operating Life Time	Hr	10,000	-	-	Hour	(1)

Note (1) Life time (Hr) of LEDs can be defined as the time in which it continues to operate under the condition Ta= 25 ± 2 °C and IF = 19.0 mArms until one of the following event occurs.

1. When the brightness becomes 50% or lower than the original.

3.3 LED Driver

- On board LED Driver (Manufacturer : SEC)

Ta= 25 ± 2 °C

Item	Symbol	Min.	Typ.	Max.	Unit	Note
Input Voltage	V _{in}	6	12	20	V	
Input Current	I	-	-	-	mA	
Input Power	P _{in}	-	2.6	2.8	W	
Operating Frequency	F _o	0.8	1.0	1.2	MHz	
Burst Ratio	D	10	-	100	%	
External PWM Dimming Control Frequency (BLIM)	F _{BLIM}	0.2	-	20	kHz	V _{in} =7~20V, BLIM=PWM 0V~3.3V

Note - Test Equipment : Fluke 45

Samsung Secret

Preliminary

4. BLOCK DIAGRAM

4.1 TFT LCD Module

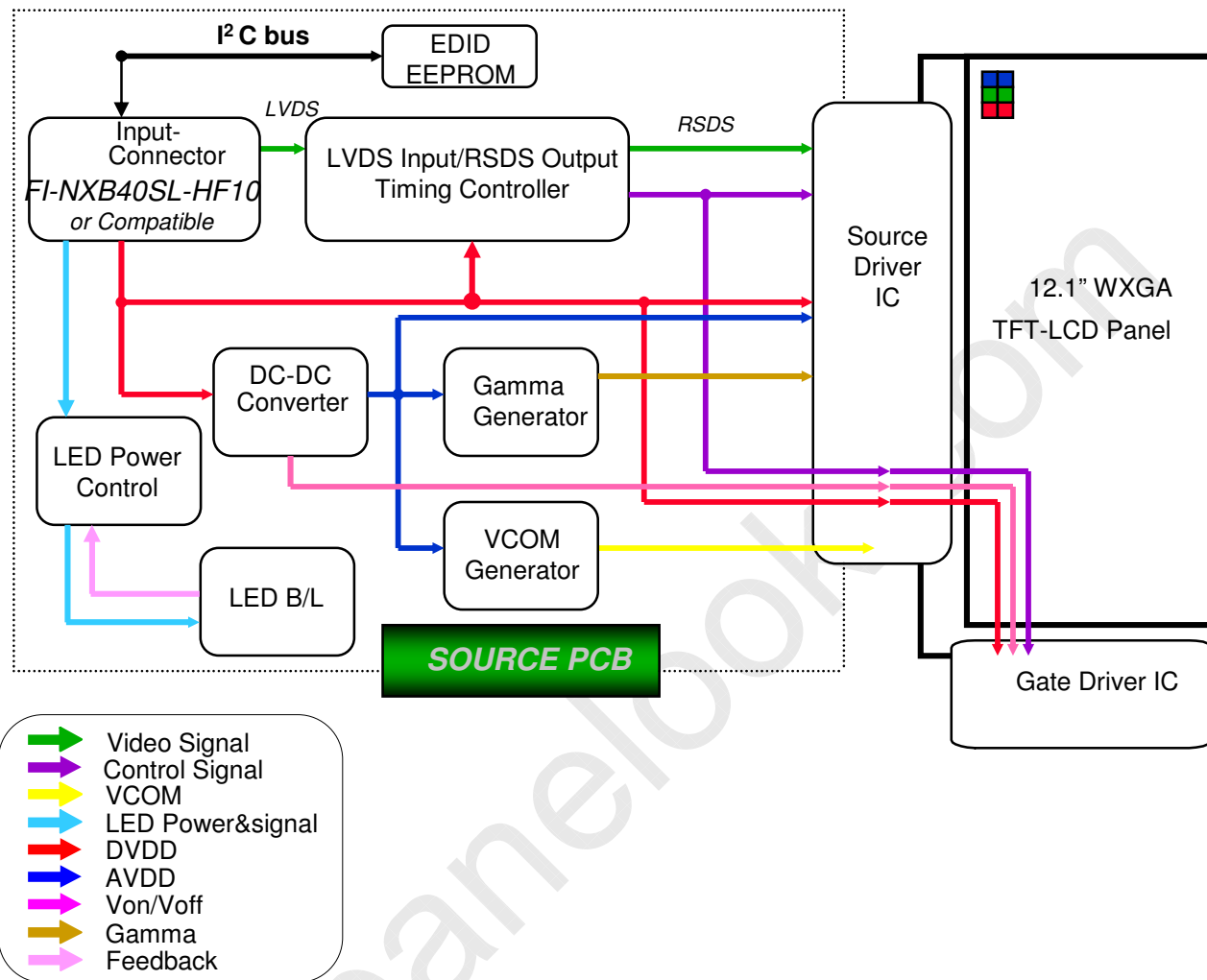

Samsung Secret

Doc.No.	LTN121AT06-L02	Rev.No	04-P00-G-090710	Page	13 / 27
----------------	----------------	---------------	-----------------	-------------	---------

Preliminary

5. INPUT TERMINAL PIN ASSIGNMENT**5.1. Input Signal & Power (LVDS, Connector : TBD)**

No.	Symbol	Function	Polarity	Remarks
1	NC	No Connection		
2	AVDD	Power Supply 3.3V (typical)		
3	AVDD	Power Supply 3.3V (typical)		
4	DVDD	DDC 3.3V power		
5	NC	No Connection		
6	SCL	DDC Clock		
7	SDA	DDC data		
8	RIN0-	LVDS differential data input (R0-R5, G0)	Negative	
9	RIN0+	LVDS differential data input (R0-R5, G0)	Positive	
10	GND	Ground		
11	RIN1-	LVDS differential data input (G1-G5, B0-B1)	Negative	
12	RIN1+	LVDS differential data input (G1-G5, B0-B1)	Positive	
13	GND	Ground		
14	RIN2-	LVDS differential data input (B2-B5, HS, VS, DE)	Negative	
15	RIN2+	LVDS differential data input (B2-B5, HS, VS, DE)	Positive	
16	GND	Ground		
17	CLK-	LVDS differential clock input	Negative	
18	CLK+	LVDS differential clock input	Positive	
19	GND	Ground		
20~21	NC	No Connection		
22	GND	Ground		
23~24	NC	No Connection		
25	GND	Ground		
26~27	NC	No Connection		
28	GND	Ground		
29~30	NC	No Connection		
31~33	VBL-	LED Power return		
34	NC	No Connection		
35~37	VBL+	7V – 20V LED power		
38	BLIM	PWM for luminance control (200~1KHz, 3.3V)		
39	BL_Enable	BL On/Off (On: 2.0~3.3V, Off: 0~0.5V)		
40	NC	No Connection		

Samsung Secret

Preliminary

5.2 LVDS Interface : Transmitter DS90CF363 or Compatible

Pin No.	Name	RGB Signal	Pin No.	Name	RGB Signal
51	TxIN0	R0	14	TxIN14	G5
52	TxIN1	R1	15	TxIN15	B0
54	TxIN2	R2	19	TxIN18	B1
55	TxIN3	R3	20	TxIN19	B2
56	TxIN4	R4	22	TxIN20	B3
3	TxIN6	R5	23	TxIN21	B4
4	TxIN7	G0	24	TxIN22	B5
6	TxIN8	G1	27	TxIN24	Hsync
7	TxIN9	G2	28	TxIN25	Vsync
11	TxIN12	G3	30	TxIN26	DE
12	TxIN13	G4	31	TxCLKIN	Clock

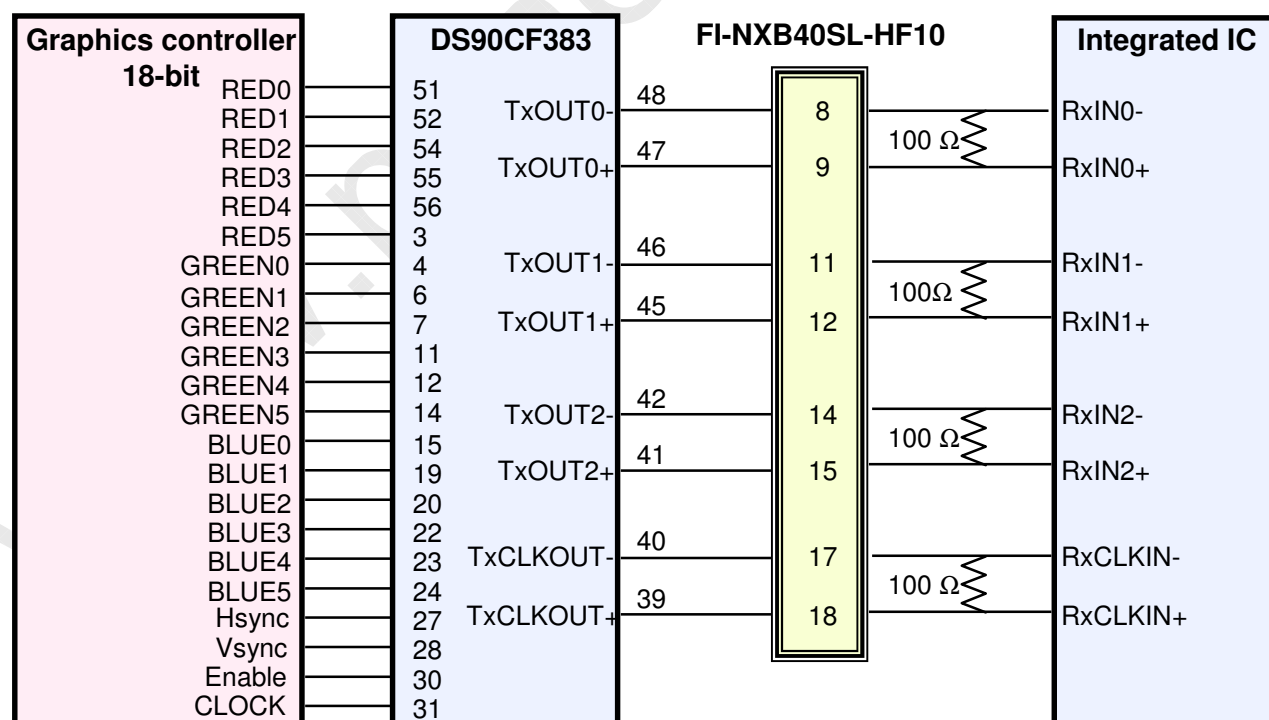
LVDS INTERFACE

Note : The LCD Module uses a 100ohm resistor between positive and negative lines of each receiver input.

Samsung Secret

Preliminary

5.3 Timing Diagrams of LVDS For Transmission

LVDS Receiver : Integrated T-CON

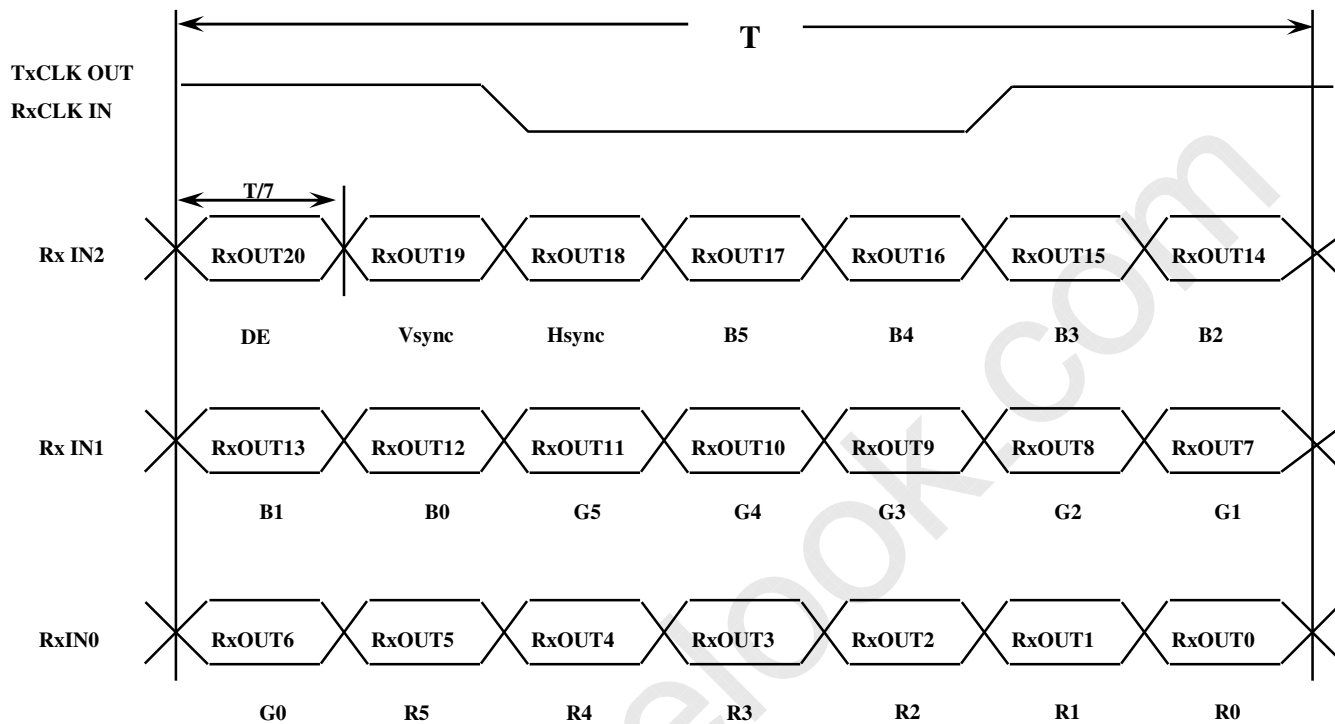

Samsung Secret

Doc.No.	LTN121AT06-L02	Rev.No	04-P00-G-090710	Page	16 / 27
----------------	----------------	---------------	-----------------	-------------	---------

Preliminary

5.4 Input Signals, Basic Display Colors and Gray Scale of Each Color

Color	Display	Data Signal																Gray Scale Level	
		Red					Green					Blue							
		R0	R1	R2	R3	R4	R5	G0	G1	G2	G3	G4	G5	B0	B1	B2	B3		45
Basic Colors	Black	0	0	0	0	0	0	0	0	0	0	0	0	0	0	0	0	0	-
	Blue	0	0	0	0	0	0	0	0	0	0	0	0	1	1	1	1	1	-
	Green	0	0	0	0	0	0	1	1	1	1	1	1	0	0	0	0	0	-
	Cyan	0	0	0	0	0	0	1	1	1	1	1	1	1	1	1	1	1	-
	Red	1	1	1	1	1	1	0	0	0	0	0	0	0	0	0	0	0	-
	Magenta	1	1	1	1	1	1	0	0	0	0	0	0	1	1	1	1	1	-
	Yellow	1	1	1	1	1	1	1	1	1	1	1	1	0	0	0	0	0	-
	White	1	1	1	1	1	1	1	1	1	1	1	1	1	1	1	1	1	-
Gray Scale Of Red	Black	0	0	0	0	0	0	0	0	0	0	0	0	0	0	0	0	0	R0
	Dark	1	0	0	0	0	0	0	0	0	0	0	0	0	0	0	0	0	R1
	↑	0	1	0	0	0	0	0	0	0	0	0	0	0	0	0	0	0	R2
	:	:	:	:	:	:	:	:	:	:	:	:	:	:	:	:	:	:	R3~R60
	:	:	:	:	:	:	:	:	:	:	:	:	:	:	:	:	:	:	
	↓	1	0	1	1	1	1	0	0	0	0	0	0	0	0	0	0	0	R61
	Light	0	1	1	1	1	1	0	0	0	0	0	0	0	0	0	0	0	R62
	Red	1	1	1	1	1	1	0	0	0	0	0	0	0	0	0	0	0	R63
Gray Scale Of Green	Black	0	0	0	0	0	0	0	0	0	0	0	0	0	0	0	0	0	G0
	Dark	0	0	0	0	0	0	1	0	0	0	0	0	0	0	0	0	0	G1
	↑	0	0	0	0	0	0	0	1	0	0	0	0	0	0	0	0	0	G2
	:	:	:	:	:	:	:	:	:	:	:	:	:	:	:	:	:	:	G3~G60
	:	:	:	:	:	:	:	:	:	:	:	:	:	:	:	:	:	:	
	↓	0	0	0	0	0	0	1	0	1	1	1	1	0	0	0	0	0	G61
	Light	0	0	0	0	0	0	0	1	1	1	1	1	0	0	0	0	0	G62
	Green	0	0	0	0	0	0	1	1	1	1	1	1	0	0	0	0	0	G63
Gray Scale Of Blue	Black	0	0	0	0	0	0	0	0	0	0	0	0	0	0	0	0	0	B0
	Dark	0	0	0	0	0	0	0	0	0	0	0	0	1	0	0	0	0	B1
	↑	0	0	0	0	0	0	0	0	0	0	0	0	0	1	0	0	0	B2
	:	:	:	:	:	:	:	:	:	:	:	:	:	:	:	:	:	:	B3~B60
	:	:	:	:	:	:	:	:	:	:	:	:	:	:	:	:	:	:	
	↓	0	0	0	0	0	0	0	0	0	0	0	0	1	0	1	1	1	B61
	Light	0	0	0	0	0	0	0	0	0	0	0	0	0	1	1	1	1	B62
	Blue	0	0	0	0	0	0	0	0	0	0	0	0	1	1	1	1	1	B63

Note 1) Definition of gray :
 Rn: Red gray, Gn: Green gray, Bn: Blue gray (n=gray level)
 Note 2) Input signal: 0 =Low level voltage, 1=High level voltage

Samsung Secret

Preliminary

5.5 Pixel Format in the display

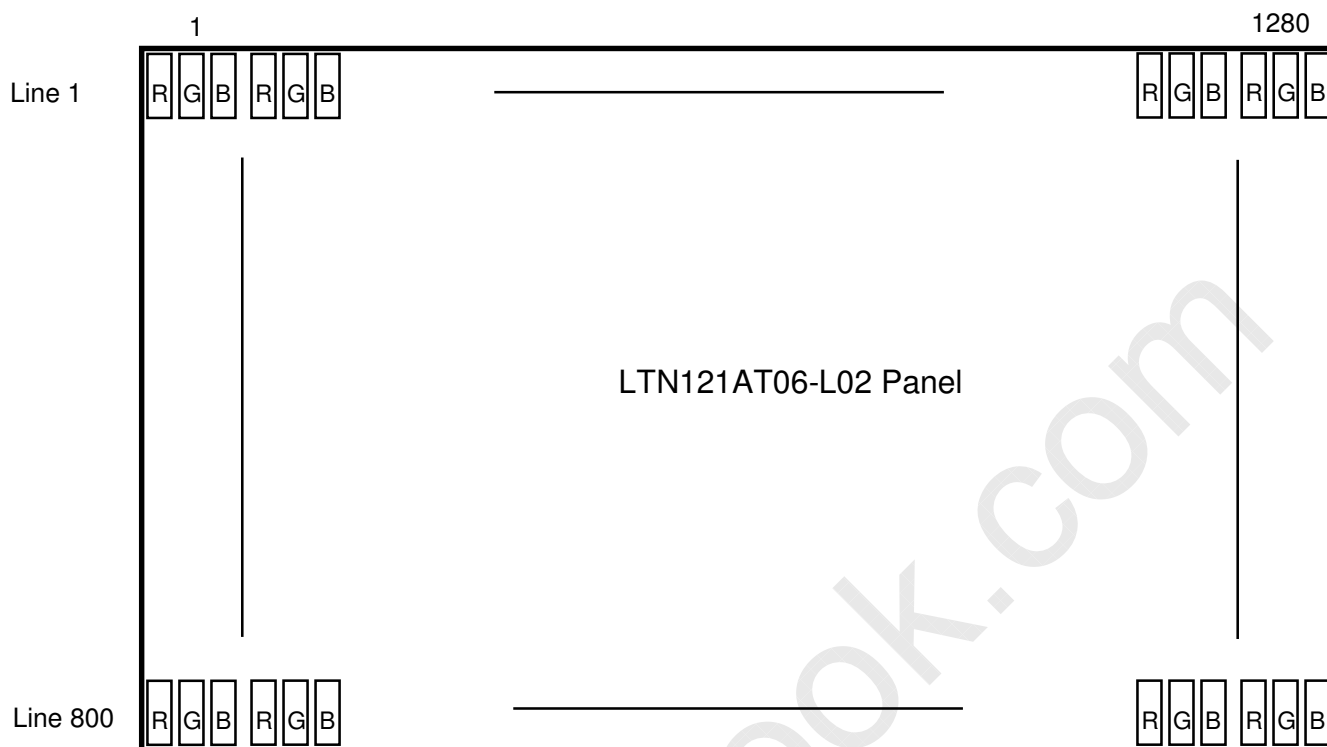
**Samsung Secret****Doc.No.**

LTN121AT06-L02

Rev.No

04-P00-G-090710

Page

18 / 27

Preliminary

6. INTERFACE TIMING

6.1 Timing Parameters

Signal	Item	Symbol	Min.	Typ.	Max.	Unit	Note
Frame Frequency	Cycle	TV	804	816	860	Lines	
Vertical Active Display Term	Display Period	TVD	-	800	-	Lines	
One Line Scanning Time	Cycle	TH	1350	1415	1460	Clocks	
Horizontal Active Display Term	Display Period	THD	-	1280	-	Clocks	

6.2 Timing diagrams of interface signal

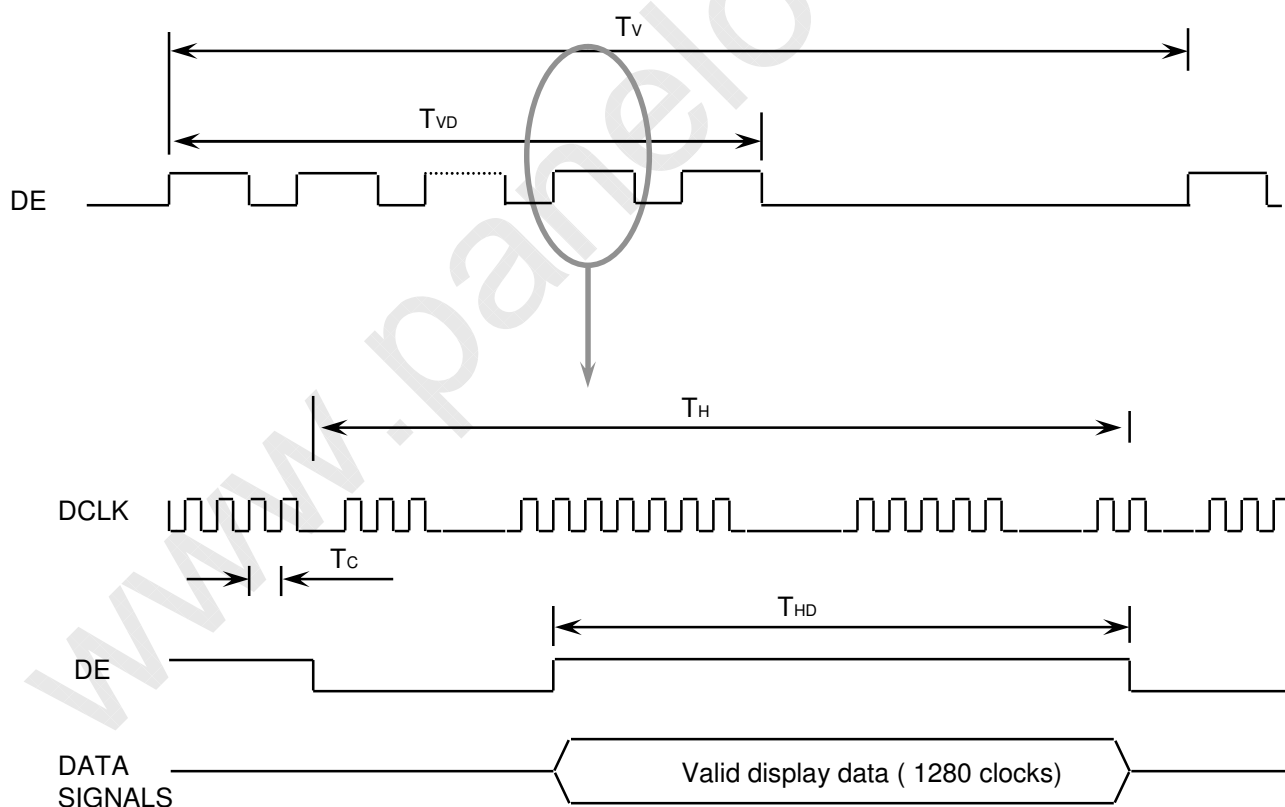

Samsung Secret

6.3 Power ON/OFF Sequence

Preliminary

: To prevent a latch-up or DC operation of the LCD module, the power on/off sequence should be as the diagram below.

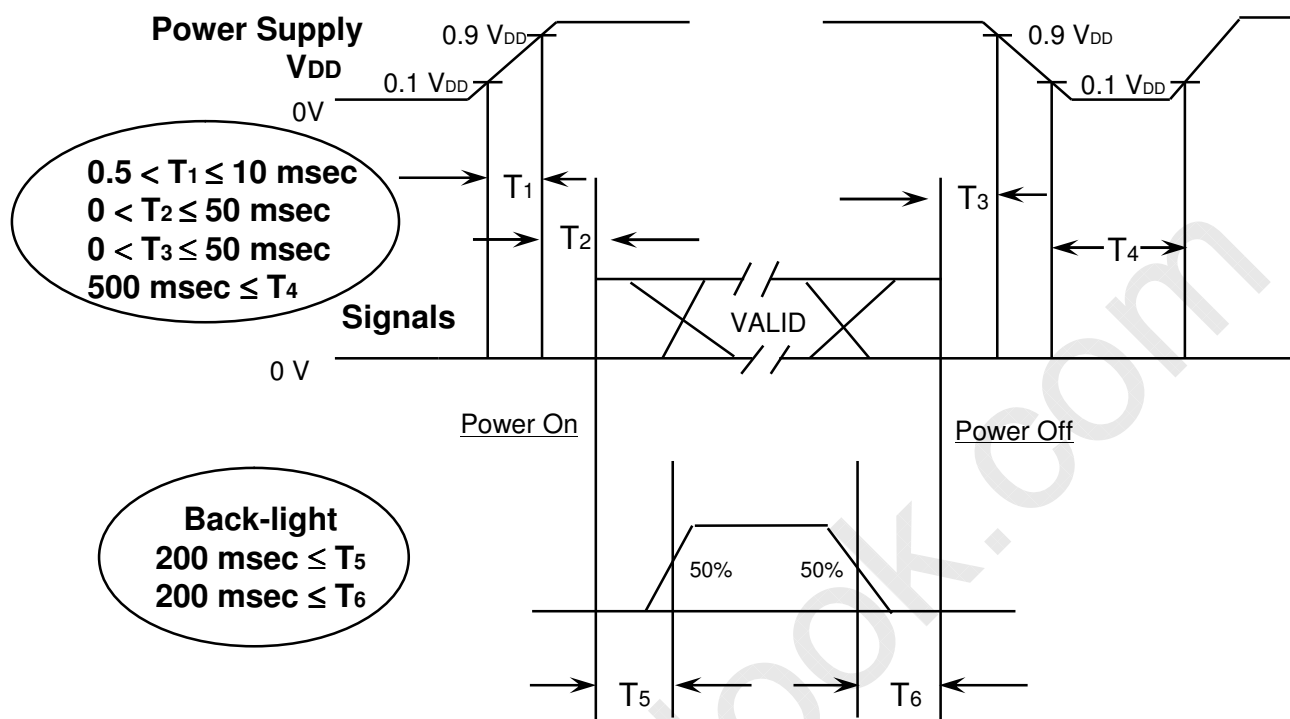
Power ON/OFF Sequence

- T1 : Vdd rising time from 10% to 90%
 T2 : The time from Vdd to valid data at power ON.
 T3 : The time from valid data off to Vdd off at power Off.
 T4 : Vdd off time for Windows restart
 T5 : The time from valid data to B/L enable at power ON.
 T6 : The time from valid data off to B/L disable at power Off.

NOTE.

- (1) The supply voltage of the external system for the module input should be the same as the definition of V_{DD} .
- (2) Apply the lamp voltage within the LCD operation range. When the back-light turns on before the LCD operation or the LCD turns off before the back-light turns off, the display may momentarily become white.
- (3) In case of $V_{DD} = \text{off level}$, please keep the level of input signals on the low or keep a high impedance.
- (4) T4 should be measured after the module has been fully discharged between power off and on period.
- (5) Interface signal shall not be kept at high impedance when the power is on.

Samsung Secret

Doc.No.	LTN121AT06-L02	Rev.No	04-P00-G-090710	Page	20 / 27
----------------	----------------	---------------	-----------------	-------------	---------

7. Mechanical Outline Dimension

Preliminary

Refer to the next page

www.panelook.com

Samsung Secret

Doc.No.	LTN121AT06-L02	Rev.No	04-P00-G-090710	Page	21 / 27
----------------	----------------	---------------	-----------------	-------------	---------

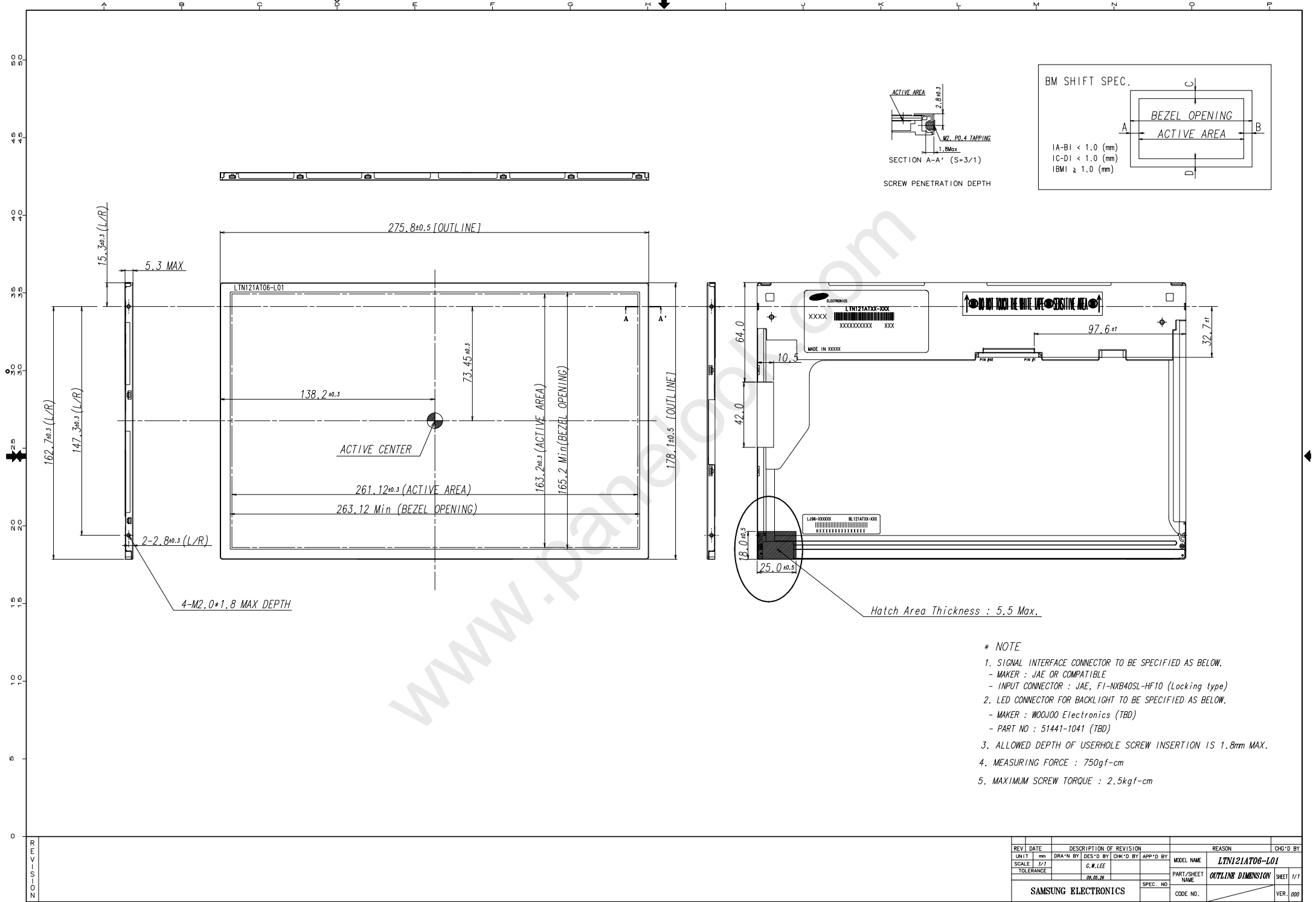

REV	DATE	DESCRIPTION OF REVISION	REASON	CHK'D BY

UNIT	mm	DRAWN BY	DES'D BY	CHK'D BY	APP'D BY	MODEL NAME	LTN121AT06-L01	
SCALE	1/1	G.W.LEE				PART/SHEET NAME	OUTLINE DIMENSION	
TOLERANCE						SPEC. NO.		
SAMSUNG ELECTRONICS							CODE NO.	
							SHEET	1/1
							VER.	000

8. PACKING

Preliminary

1. CARTON(Internal Package)

(1) Packing Form

Corrugated Cardboard box and EPS form as shock absorber

(2) Packing Method

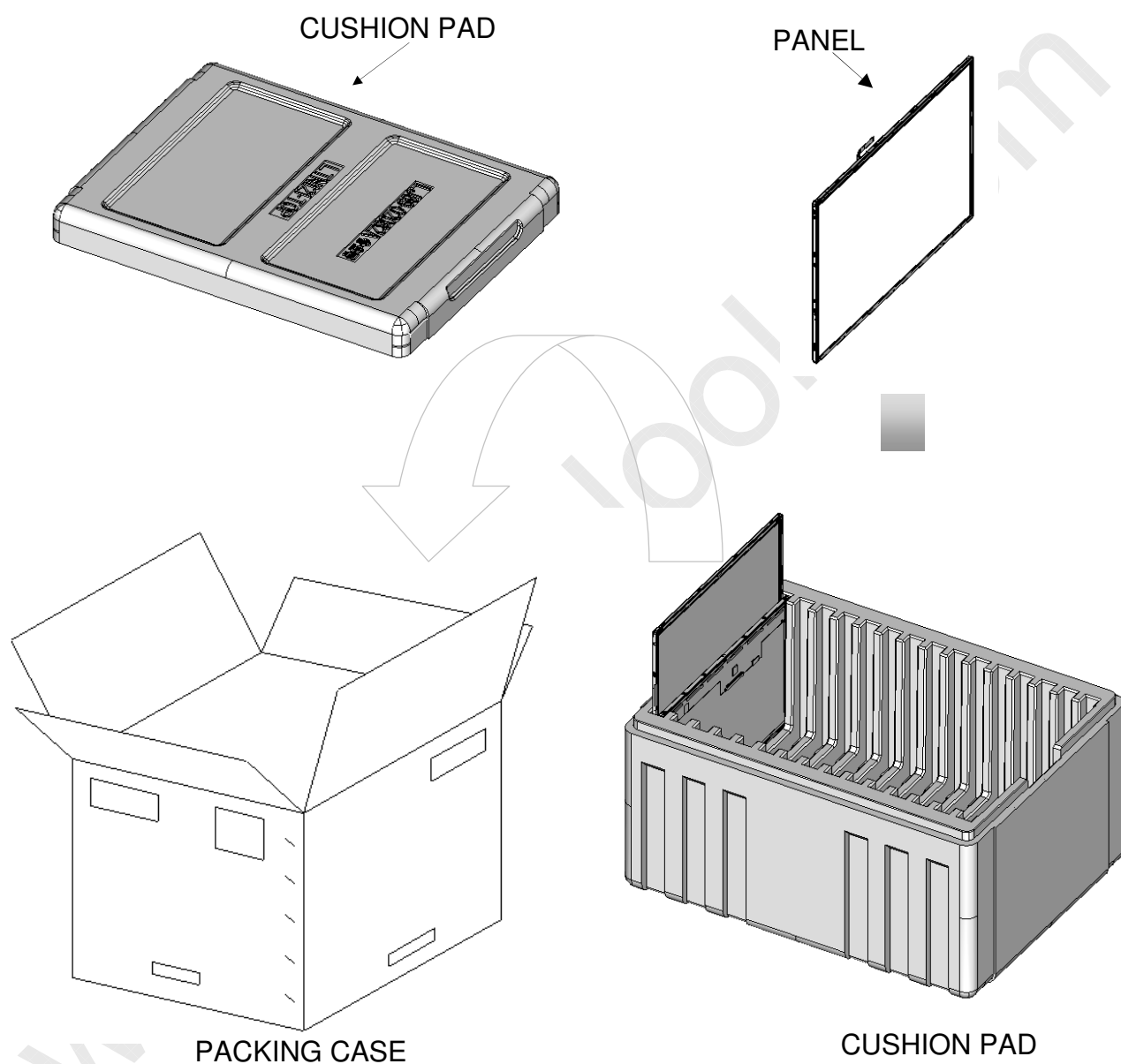

Note 1) Total Weight : Approximately (7.8) kg

2) Acceptance number of piling : 30 sets

3) Carton size : 356(L)*475(W)*278(H)

Samsung Secret

Doc.No.

LTN121AT06-L02

Rev.No

04-P00-G-090710

Page

23 / 27

Preliminary

(3)Packing Material

No	Part name	Quantity
1	Static electric protective sack	30
2	Packing case (Inner box) included shock absorber	1 set
3	Pictorial marking	2 pcs
4	Carton	1 set

9. MARKINGS & OTHERS

A nameplate bearing followed by is affixed to a shipped product at the specified location on each product.

(1)Parts number : LTN121AT06

(2)Revision code : 3 letters

(3)Lot number : X X X X XXX XX X **L02**

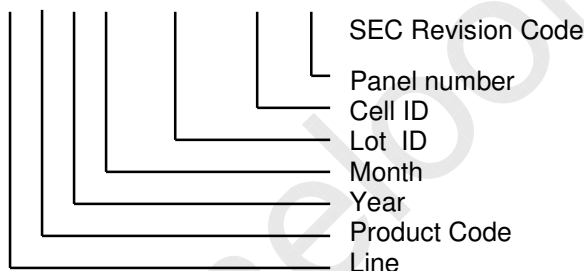

(4) Nameplate Indication

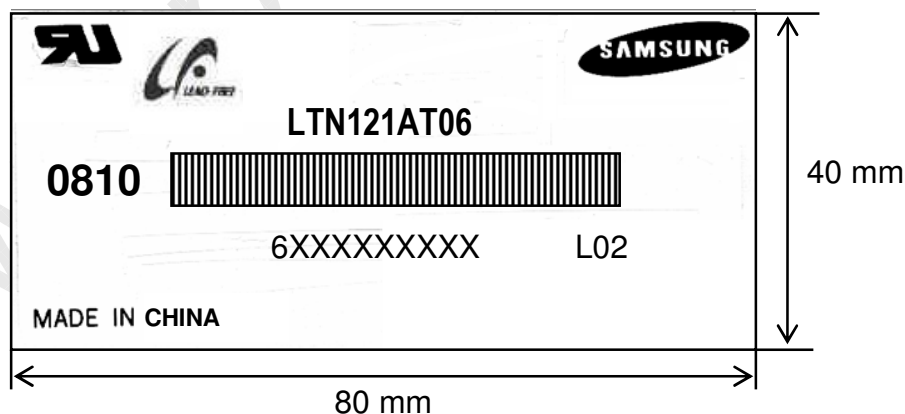

Parts name : LTN121AT06-L02
 Lot number : XXXXXXXXXXXX
 Inspected work week : 0810(2008 year, 10th week)
 Product Revision Code : L02
 Production Site : CHINA(ESL)

Samsung Secret

Preliminary

(5) High voltage caution notice

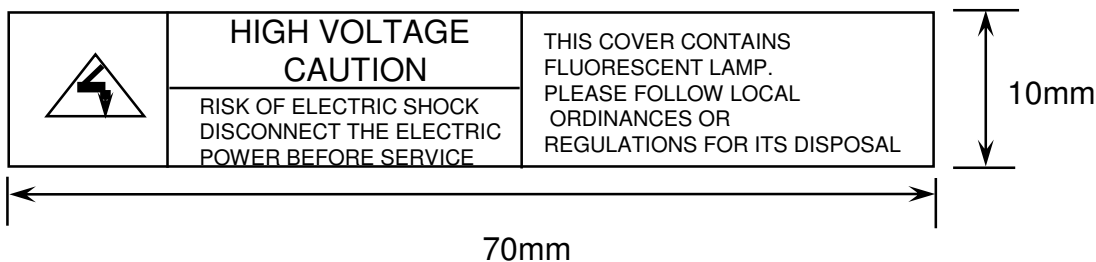

(6) Packing small box attach

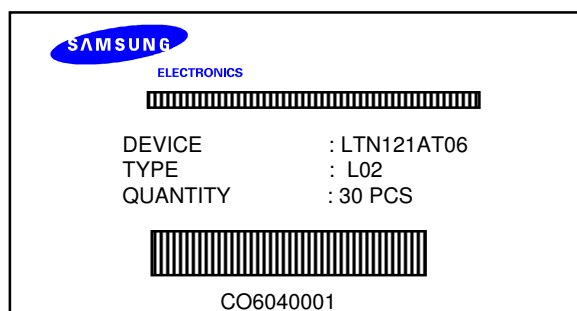

(7) Packing box Marking : Samsung TFT-LCD Brand Name



Samsung Secret

10. GENERAL PRECAUTIONS

Preliminary

1. Handling

- (a) When the module is assembled, It should be attached to the system firmly using every mounting holes. Be careful not to twist and bend the modules.
- (b) Refrain from strong mechanical shock and / or any force to the module. In addition to damage, this may cause improper operation or damage to the module and CCFT back-light.
- (c) Note that polarizers are very fragile and could be easily damaged. Do not press or scratch the surface harder than a HB pencil lead.
- (d) Wipe off water droplets or oil immediately. If you leave the droplets for a long time, Staining and discoloration may occur.
- (e) If the surface of the polarizer is dirty, clean it using some absorbent cotton or soft cloth.
- (f) The desirable cleaners are water, IPA (Isoprophyl Alcohol) or Hexane. Do not use Ketone type materials(ex. Acetone), Ethyl alcohol, Toluene, Ethyl acid or Methyl chloride. It might permanent damage to the polarizer due to chemical reaction.
- (g) If the liquid crystal material leaks from the panel, it should be kept away from the eyes or mouth. In case of contact with hands, legs or clothes, it must be washed away thoroughly with soap.
- (h) Protect the module from static, it may cause damage to the C-MOS Gate Array IC.
- (i) Use fingerstalls with soft gloves in order to keep display clean during the incoming inspection and assembly process.
- (j) Do not disassemble the module.
- (k) Do not pull or fold the lamp wire.
- (l) Do not adjust the variable resistor which is located on the back side.
- (m) Protection film for polarizer on the module shall be slowly peeled off just before use so that the electrostatic charge can be minimized.
- (n) Pins of I/F connector shall not be touched directly with bare hands.

Samsung Secret

Doc.No.	LTN121AT06-L02	Rev.No	04-P00-G-090710	Page	26 / 27
----------------	----------------	---------------	-----------------	-------------	---------

Preliminary

2. STORAGE

- (a) Do not leave the module in high temperature, and high humidity for a long time.
It is highly recommended to store the module with temperature from 0 to 35 °C and relative humidity of less than 70%.
- (b) Do not store the TFT-LCD module in direct sunlight.
- (c) The module shall be stored in a dark place. It is prohibited to apply sunlight or fluorescent light during the store.

3. OPERATION

- (a) Do not connect,disconnect the module in the " Power On" condition.
- (b) Power supply should always be turned on/off by following item 6.3 " Power on/off sequence " .
- (c) Module has high frequency circuits. Sufficient suppression to the electromagnetic interference shall be done by system manufacturers. Grounding and shielding methods may be important to minimize the interference.
- (d) The cable between the back-light connector and its inverter power supply shall be a minimized length and be connected directly . The longer cable between the back-light and the inverter may cause lower luminance of lamp(CCFT) and may require higher startup voltage (Vs).
- (e) The standard limited warranty is only applicable when the module is used for general notebook applications. If used for purposes other than as specified, SEC is not to be held reliable for the defective operations. It is strongly recommended to contact SEC to find out fitness for a particular purpose.

4. OTHERS

- (a) Ultra-violet ray filter is necessary for outdoor operation.
- (b) Avoid condensation of water. It may result in improper operation or disconnection of electrode.
- (c) Do not exceed the absolute maximum rating value. (the supply voltage variation, input voltage variation, variation in part contents and environmental temperature, so on)
Otherwise the module may be damaged.
- (d) If the module displays the same pattern continuously for a long period of time,it can be the situation when the image "sticks" to the screen.
- (e) This module has its circuitry PCB's on the rear side and should be handled carefully in order not to be stressed.

Samsung Secret

Doc.No.	LTN121AT06-L02	Rev.No	04-P00-G-090710	Page	27 / 27
----------------	----------------	---------------	-----------------	-------------	---------

Preliminary

11. EDID

Address (HEX)	FUNCTION	Value	BIN	DEC	ASCII or Data	Notes
		HEX				
00	Header	00	00000000	0		EDID Header
01		FF	11111111	255		
02		FF	11111111	255		
03		FF	11111111	255		
04		FF	11111111	255		
05		FF	11111111	255		
06		FF	11111111	255		
07		00	00000000	0		
08	ID Manufacturer Name	4C	01001100	76	S	3 character ID
09		A3	10100011	163	E C	
0A	ID Product Code	54	01010100	84	[T]	"AT"
0B		47	01000111	71	[G]	"G01"
0C	32-bit serial no.	00	00000000	0		
0D		00	00000000	0		
0E		00	00000000	0		
0F		00	00000000	0		
10	Week of manufacture	00	00000000	0		
11	Year of manufacture	12	00010010	18	2008	2008
12	EDID Structure Ver.	01	00000001	1	1	EDID Ver. 1.0
13	EDID revision #	03	00000011	3	3	EDID Rev. 3
14	Video input definition	80	10000000	128		
15	Max H image size	1A	00011010	26	26	26 cm(approx)
16	Max V image size	10	00010000	16	16	16 cm(approx)
17	Display Gamma	78	01111000	120	2.2	Gamma 2.2
18	Feature support	0A	00001010	10		
19	Red/green low bits	D3	11010011	211		10000111
1A	Blue/white low bits	E5	11100101	229		11111110
1B	Red x/ high bits	95	10010101	149	0.585	Red x 0.580= 10010101
1C	Red y	5C	01011100	92	0.360	Red y 0.360= 01011100
1D	Green x	60	01100000	96	0.375	Green x 0.375= 01100000
1E	Green y	90	10010000	144	0.565	Green y 0.565= 10010000
1F	Blue x	27	00100111	39	0.155	Blue x 0.155= 00100111
20	Blue y	19	00011001	25	0.100	Blue y 0.100= 00011001
21	White x	50	01010000	80	0.313	White x 0.313= 01010000
22	White y	54	01010100	84	0.329	White y 0.329= 01010100
23	Established timing 1	00	00000000	0		
24	Established timing 2	00	00000000	0		
25	Established timing 3	00	00000000	0		

Samsung Secret

Preliminary

26	Standard timing #1	01	00000001	1		not used	
27		01	00000001	1			
28	Standard timing #2	01	00000001	1		not used	
29		01	00000001	1			
2A	Standard timing #3	01	00000001	1		not used	
2B		01	00000001	1			
2C	Standard timing #4	01	00000001	1		not used	
2D		01	00000001	1			
2E	Standard timing #5	01	00000001	1		not used	
2F		01	00000001	1			
30	Standard timing #6	01	00000001	1		not used	
31		01	00000001	1			
32	Standard timing #7	01	00000001	1		not used	
33		01	00000001	1			
34	Standard timing #8	01	00000001	1		not used	
35		01	00000001	1			
36	Detailed timing/monitor descriptor #1	EE	11101110	238	68.94	Main clock= 68.94 MHz	
37		1A	00011010	26			
38		00	00000000	0	1280	Hor active=640*2 pixels	
39		80	10000000	128	128	Hor blanking=128 pixels	
3A		50	01010000	80		4bit : 4bit	
3B		20	00100000	32	800	Vertical active=800 lines	
3C		10	00010000	16	16	Vertical blanking=16 lines	
3D		30	00110000	48		4bit : 4bit	
3E		10	00010000	16	16	Hor sync. Offset=12 pixels	
3F		30	00110000	48	48	H sync. Width=48 pixels	
40			33	00110011	51	3	V sync. Offset=3 lines
							3
41			00	00000000	0		2bit : 2bit :2bit :2bit
42			05	00000101	5	261	H image size= 261 mm(approx)
43			A3	10100011	163	163	V image size = 163mm(approx)
44			10	00010000	16		
45			00	00000000	0		No Horizontal Border
46		00	00000000	0		No Vertical Border	
47		19	00011001	25			
48	Detailed timing/monitor descriptor #2	00	00000000	0		Manufacturer Specified (Timing)	
49		00	00000000	0			
4A		00	00000000	0			
4B		0F	00001111	15			
4C		00	00000000	0			
4D		00	00000000	0		Value=HSPWmin / 2	
4E		00	00000000	0		Value=HSPWmax / 2	
4F		00	00000000	0		Value=Thbpmin / 2	
50		00	00000000	0		Value=Thbpmax / 2	
51		00	00000000	0		Value=VSPWmin / 2	
52		00	00000000	0		Value=VSPWmax / 2	
53		00	00000000	0		Value=Tvbpmin / 2	
54		00	00000000	0		Value=Tvbpmax / 2	
55		23	00100011	35		Thpmin=value*2 + HA pixelclks	
56		87	10000111	135		Thpmax=value*2 + HA pixelclks	
57		02	00000010	2		Tvpmin=value*2 + VA lines	
58		64	01100100	100		Tvpmax=value*2 + VA lines	
59	00	00000000	0		Module revision		

Samsung Secret

Preliminary

5A	Detailed timing/monitor descriptor #3	00	00000000	0		ASCII Data String Tag
5B		00	00000000	0		
5C		00	00000000	0		
5D		FE	11111110	254		
5E		00	00000000	0		
5F		53	01010011	83	[S]	
60		41	01000001	65	[A]	
61		4D	01001101	77	[M]	
62		53	01010011	83	[S]	
63		55	01010101	85	[U]	
64		4E	01001110	78	[N]	
65		47	01000111	71	[G]	
66		0A	00001010	10	[^]	
67		20	00100000	32	[]	
68		20	00100000	32	[]	
69		20	00100000	32	[]	
6A	20	00100000	32	[]		
6B	20	00100000	32	[]		
6C	Detailed timing/monitor descriptor #4	00	00000000	0		Monitor Name Tag (ASCII)
6D		00	00000000	0		
6E		00	00000000	0		
6F		FE	11111110	254		
70		00	00000000	0		
71		4C	01001100	76	[L]	
72		54	01010100	84	[T]	
73		4E	01001110	78	[N]	
74		31	00110001	49	[1]	
75		32	00110010	50	[2]	
76		31	00110001	49	[1]	
77		41	01000001	65	[A]	
78		54	01010100	84	[T]	
79		30	00110000	48	[0]	
7A		36	00110110	54	[6]	
7B		4C	01001100	76	[L]	
7C	30	00110000	48	[0]		
7D	32	00110010	50	[2]		
7E	Extension Flag	00	00000000	0		
7F	Checksum	23	00100011	35		

Samsung Secret