

SAMSUNG

ELECTRONICS

Approval

TO : Lenovo

DATE : Oct 20. 2004

SAMSUNG TFT-LCD**MODEL NO. : LTN121XA-L01**

[Lead free product]

Notes :

Any Modification of Spec is not allowed without SEC' permission

APPROVED BY :

*K. H. Shin*PREPARED BY : LCD Application Engineering Group, LCD Business**SAMSUNG ELECTRONICS CO., LTD.**

Doc.No.

LTN121XA-L01

Rev.No

04 - A05 -G - 041020

Page

1 / 27

SEC Secret

Approval

CONTENTS

Revision History	----- (3)
General Description	----- (4)
1. Absolute Maximum Ratings	----- (5)
1.1 Absolute Ratings Of Environment	
1.2 Electrical Absolute Ratings	
2. Optical Characteristics	----- (7)
3. Electrical Characteristics	----- (10)
3.1 TFT LCD Module	
3.2 Back-light Unit	
4. Block Diagram	----- (13)
4.1 TFT LCD Module	
4.2 Back-light Unit	
5. Input Terminal Pin Assignment	----- (14)
5.1 Input Signal & Power	
5.2 LVDS Interface	
5.3 Back-light Unit	
5.4 Timing Diagrams of LVDS For Transmitting	
5.5 Input Signals, Basic Display Colors and Gray Scale of Each Color.	
5.6 Pixel format	
6. Interface Timing	----- (19)
6.1 Timing Parameters	
6.2 Timing Diagrams of interface Signal	
6.3 Power ON/OFF Sequence	
7. Outline Dimension	----- (21)
8. PACKING	----- (22)
9. Marking & Others	----- (23)
10. General Precautions	----- (25)

Revision History

Approval

Date	Rev.No.	Page	Summary		
June,2 ,2003	P00	All	LTN121XA-L01 MODEL IS FIRST ISSUED.		
Sep.23,2003	P01	7	- Insert RGB Colors coordinates.		
		21	- Removed the edge of rib in Mold Frame		
		23	- Product Label Revision(IBM P/N, FRU P/N, EC NO, Header Code)		
Oct.17,2003	A00	All	- Revised to approval version		
Oct,30,2003	A01	7	- Changed 5P brightness spec from 110nits to 112nits.		
		10	- Revision of power consumption specification @Vdd=3.3 V White : Typ 330mA → Typ 270mA Mosaic : Typ 360mA → Typ 300mA Win 98 : Typ 360mA → Typ 330mA Max(1Dort) : Max 360mA		
		12	- Changed Open voltage specification from 1420Vrms to 1400Vrms		
		21	- Change of wire tape length from 42mm To Typ27mm		
Nov.13,2003	A02	23	- IBM P/N correction: 92P6686 - FRU P/N correction: 92P6685		
Apr. 7,2004	A03	22	- PCB cover changed for improvement of white spot		
		24	- Product label revision by implementation of new cushion . SEC Revision code : 000 →001 . IBM P/N : 92P6686 →92P6729 . FRU P/N : 92P6685 →92P6728 . EC NO : J17690 the same code . H/C : 1Z8DZ →1Z9D9		
May 6,2004	A03	24	- ECR approved (Vcst signal change from Vcom to Voff) . SEC Revision code : 001 →002 . IBM P/N : 92P6729 the same code . FRU P/N : 92P6728 the same code . EC NO : J17690 → J17696 . H/C : 1Z9D9 →1Z9EF		
May 24,2004		24	- ECR approved (C/F vendor change from ACTI to SEC) . SEC Revision code : 002 the same code . IBM P/N : 92P6729 the same code . FRU P/N : 92P6728 the same code . EC NO : J17696 the same code . H/C : 1Z9EF → 1Z9J6		
Doc.No.	LTN121XA-L01	Rev.No	04 - A05 -G - 041020	Page	3 / 27

SEC Secret

Revision History

Approval

Date	Rev.No.	Page	Summary
May 25 ,2003	A03	22	-ECR Approval - Position change of product label to prevent from overlapping new cushion
Sep 21,2004	A04	24	-ECR approved for improvement of clicking noise issue . SEC Revision code : 003 . IBM P/N : 92P6729 the same code . FRU P/N : 92P6728 the same code . EC NO : J17696 the same code . H/C : 1Z9XP
Oct 20,2004	A05	24	- ECR issue : Component change for lead-free product . SEC Revision code : 004 . IBM P/N : 92P6755 . FRU P/N : 92P6754 . EC NO : Blank . H/C : 1Z9YV -Change of power sequence spec by IBM's request 0 < T3 < 50ms → 0 < T3 400ms < T4 → 150ms < T4 200ms < T6 → 0 < T6

Doc.No.

LTN121XA-L01

Rev.No

04 - A05 -G - 041020

Page

4 / 27

SEC Secret

Approval

GENERAL DESCRIPTION

DESCRIPTION

LTN121XA-L01 is a color active matrix TFT (Thin Film Transistor) liquid crystal display (LCD) that uses amorphous silicon TFT as a switching devices. This model is composed of a TFTLCD panel, a driver circuit and a back-light system. The resolution of a 12.1 " contains 1024 x 768 pixels and can display up to 262,144 colors. 6 o'clock direction is the optimum viewing angle.

FEATURES

- Ultra Thin and light weight
- High contrast ratio
- XGA (1024x768 pixels) resolution
- Low power consumption
- DE (Data enable) only mode.
- 3.3V LVDS Interface with 1 pixel / clock

APPLICATIONS

- Notebook PC and desktop monitors
- If the usage of this product is not for PC application, but for others, please contact SEC.

GENERAL INFORMATION

ITEM	SPECIFICATION	UNIT	NOTE
Display area	245.76(H) x 184.32(V) (12.1" diagonal)	mm	
Driver element	a-Si TFT active matrix		
Display colors	262,144	Color	
Number of pixel	1024 x 768 (XGA)	pixel	
Pixel arrangement	RGB vertical stripe		
Pixel pitch	0.240(H) x 0.240(V) (TYP.)	mm	
Display Mode	Normally white		
Surface treatment Of Polarizer	HAZE Typ 40, HARDNESS 2H, (ARC150T or GH5)		

Approval

MECHANICAL INFORMATION

ITEM		MIN.	TYP.	MAX.	NOTE
Module size	Horizontal (H)	260.6	261.0	261.4	
	Vertical (V)	196.6	197.0	197.4	
	Thickness(T)	-	4.7	5.0	(1)
Weight		-	260	270	g

Note (1) Measurement condition of outline dimension
. Equipment : Vernier Calipers
. Push Force : 500g · f (minimum)

1. ABSOLUTE MAXIMUM RATINGS

1.1 ABSOLUTE RATINGS OF ENVIRONMENT

ITEM	SYMBOL	MIN.	MAX.	UNIT	NOTE
Storage temperature	T_{STG}	-25	60	°C	(1)
Operating temperature (Temperature of glass surface)	T_{OPR}	0	50	°C	(1)
Shock (non-operating)	Snop	-	220	G	(2),(4)
Vibration (non-operating)	Vnop	-	1.5	G	(3),(4)

Note (1) Temperature and relative humidity range are shown in the figure below.
90 % RH Max. ($40\text{ °C} \geq T_a$)
Maximum wet - bulb temperature at 39 °C or less. ($T_a > 40\text{ °C}$) No condensation.

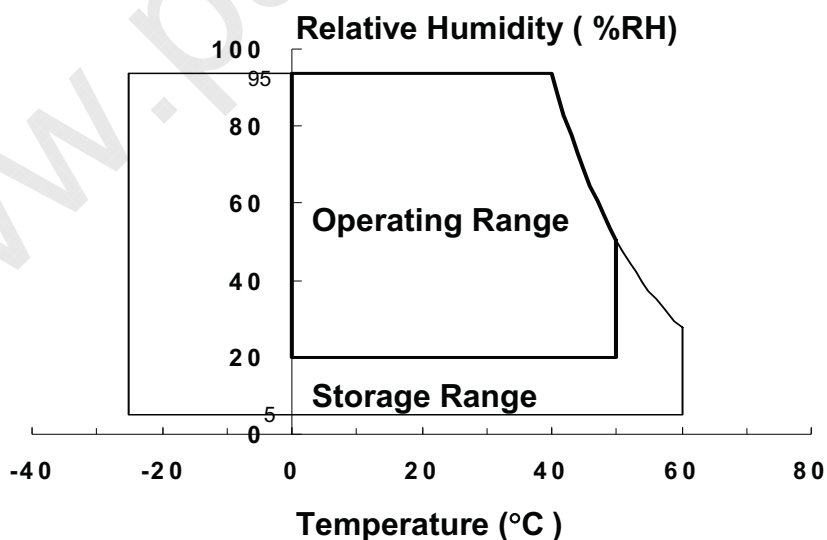

- (2) 2ms, half sine wave, one time for $\pm X, \pm Y, \pm Z$.
(3) 10 - 300 Hz, Sweep rate 10 min, 30min for X,Y,Z.
(4) At testing Vibration and Shock, the fixture in holding the Module to be tested have to be hard and rigid enough so that the Module would not be twisted or bent by the fixture.

Approval

1.2 ELECTRICAL ABSOLUTE RATINGS

(1) TFT LCD MODULE

(V_{SS} = GND = 0 V)

ITEM	SYMBOL	MIN.	MAX.	UNIT	NOTE
Power Supply Voltage	V _{DD}	V _{SS} -0.3	V _{DD} +0.3	V	(1)
Logic Input Voltage	V _{IN}	V _{SS} -0.3	V _{DD} +0.3	V	(1)

NOTE (1) Within Ta = 25 ± 2 °C

(2) BACK-LIGHT UNIT

Ta = 25 ± 2 °C

ITEM	SYMBOL	MIN.	MAX.	UNIT.	NOTE
Lamp current	IL	2.0	6.5	mA _{rms}	(1)
Lamp frequency	FL	50	80	KHz	(1)

NOTE (1) Permanent damage to the device may occur if maximum values are exceeded.
Functional operation should be restricted to the conditions described under Normal Operating Conditions.

Approval

2. OPTICAL CHARACTERISTICS

The following items are measured under stable conditions. The optical characteristics should be measured in a dark room or equivalent state with the methods shown in Note (5).

Measuring equipment : TOPCON BM-5A , PR650

* Ta = 25 ± 2°C , VDD=3.3V, fv= 60Hz, fdCLK=65MHz, IL = 6.0mA

ITEM	SYMBOL	CONDITION	MIN.	TYP.	MAX.	UNIT	NOTE	
Contrast Ratio (5 Points)	CR		200	250	-		(1), (2), (5)	
Response Time at Ta	Rising	TR	-	10	20	msec	(1), (3)	
	Falling	TF	-	30	50			
Average Luminance of White (Center)	YL,AVE	$\phi = 0,$	120	150	-	cd/m ²	(1), (4) IL = 6.0mA	
Average Luminance of White (5P AVG)	YL,AVE		112	140				
Color Chromaticity (CIE)	Red	Rx	$\theta = 0$ Normal Viewing Angle	0.563	0.593	0.623	Measured by PR 650	
		Ry		0.309	0.339	0.369		
	Green	Gx		0.283	0.313	0.343		
		Gy		0.498	0.528	0.558		
	Blue	Bx		0.121	0.151	0.181		(1), (5)
		By		0.100	0.130	0.160		
	White	Wx		0.285	0.313	0.341		
		Wy		0.309	0.329	0.349		
Viewing Angle	Hor.	θ_L	CR(at center point) ≥ 10	40	45	-	Degrees	
		θ_R		40	45	-		
	Ver.	ϕ_H		10	15	-		
		ϕ_L		30	35	-		
13 Points White Variation	δ_{13L}		65	-	-	%	(6), (7)	
5 Points White Variation	δ_{5L}		80	-	-			

Approval

Note 1) Definition of Viewing Angle : Viewing angle range($10 \leq C/R$)

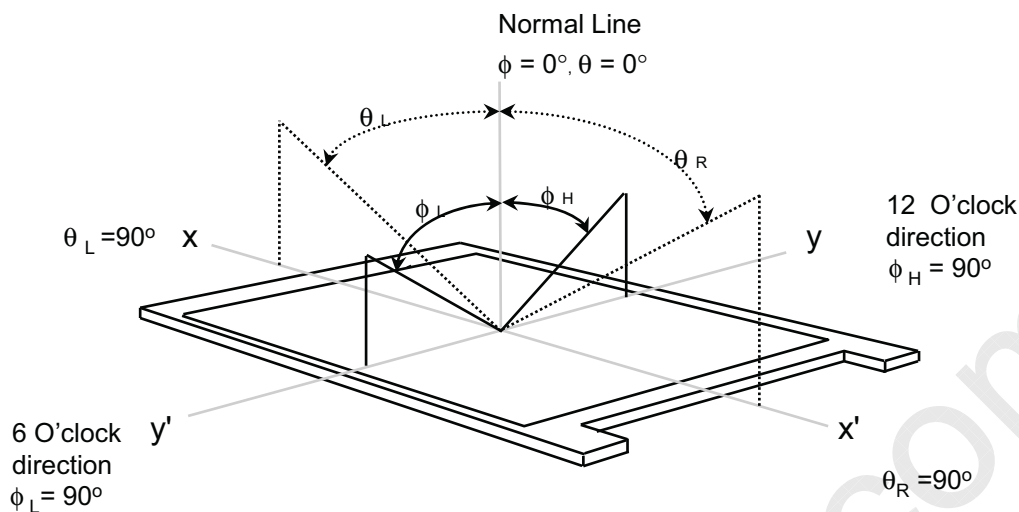

Note 2) Definition of Contrast Ratio (CR) : Ratio of gray max (Gmax) ,gray min (Gmin) at 5 points(4, 5, 7, 9, 10)

$$CR = \frac{CR(4) + CR(5) + CR(7) + CR(9) + CR(10)}{5}$$

POINTS : (4) , (5) , (7) , (9) , (10) at FIGURE OF NOTE 6)

Note 3) Definition of Response time :

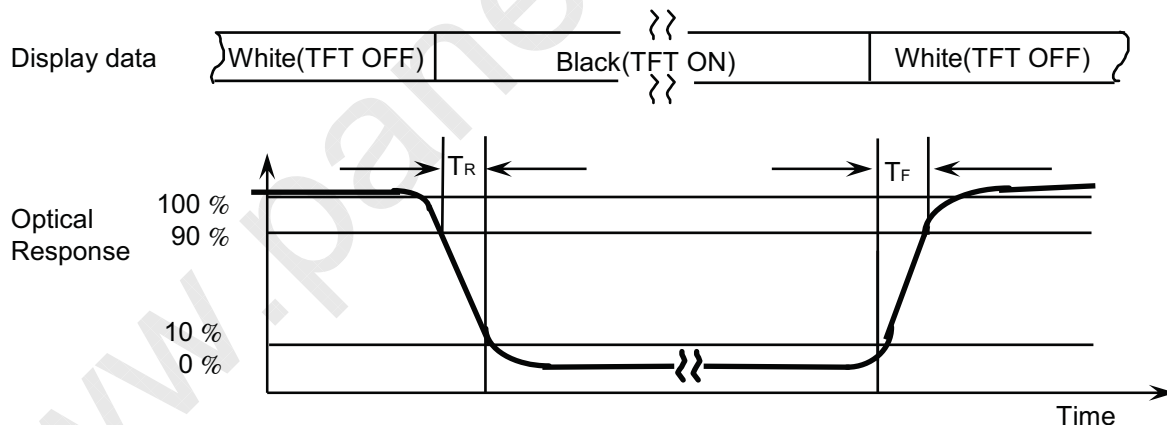

Note 4) Definition of Average Luminance of White : measure the luminance of white at 5 points.

Average Luminance of White (Y_L)

$$Y_{center} = Y_{L7}$$

$$Y_{5AVG} = \frac{Y_{L4} + Y_{L5} + Y_{L7} + Y_{L9} + Y_{L10}}{5}$$

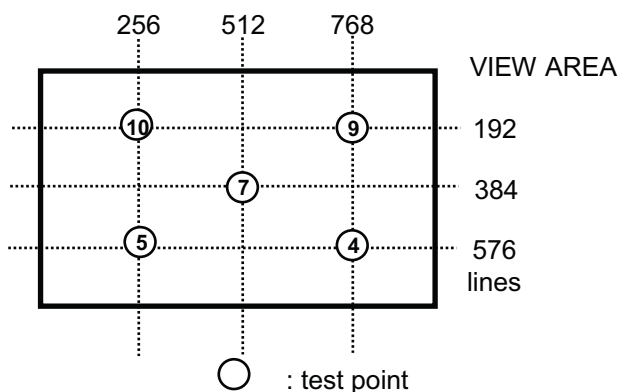

Approval

Note 5) After stabilizing and leaving the panel alone at a given temperature for 30 minutes, the measurement should be executed. Measurement should be executed in a stable, windless, and dark room. 30 minutes after lighting the back-light. This should be measured in the center of screen.

Lamp current : 6.0 mA

Environment condition : Ta = 25 ± 2 °C

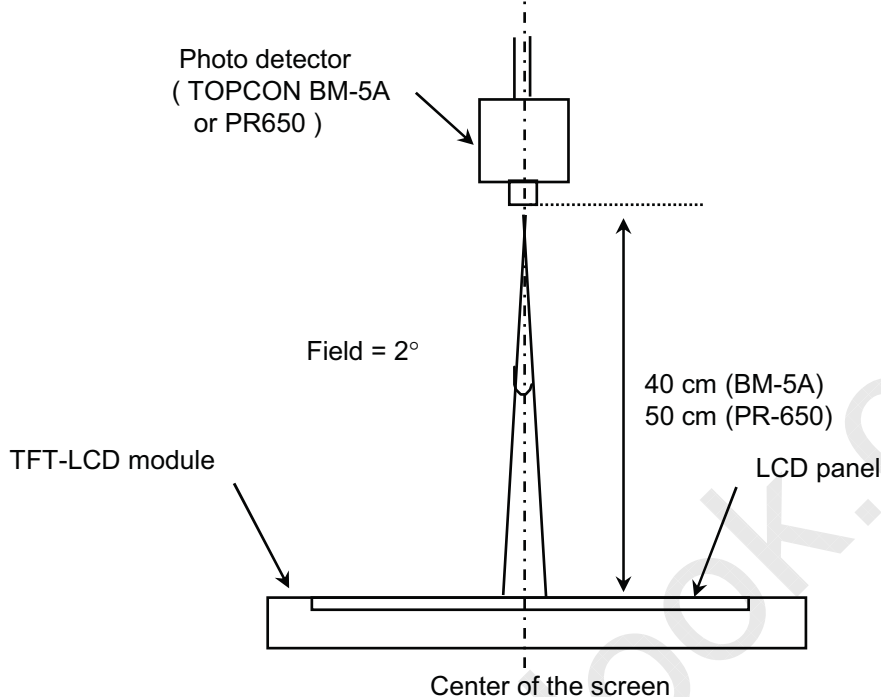

Optical characteristics measurement setup

Note 6) Definition of 13 points white variation (δ_w) [① ~ ⑬]

$$\delta_{13L} = \frac{\text{Minimum luminance of 13 points}}{\text{Maximum luminance of 13 points}}$$

Note 7) Definition of 5 points white variation (δ_w) [④ ⑤ ⑦ ⑨ ⑩]

$$\delta_{5L} = \frac{\text{Minimum luminance of 5 points}}{\text{Maximum luminance of 5 points}}$$

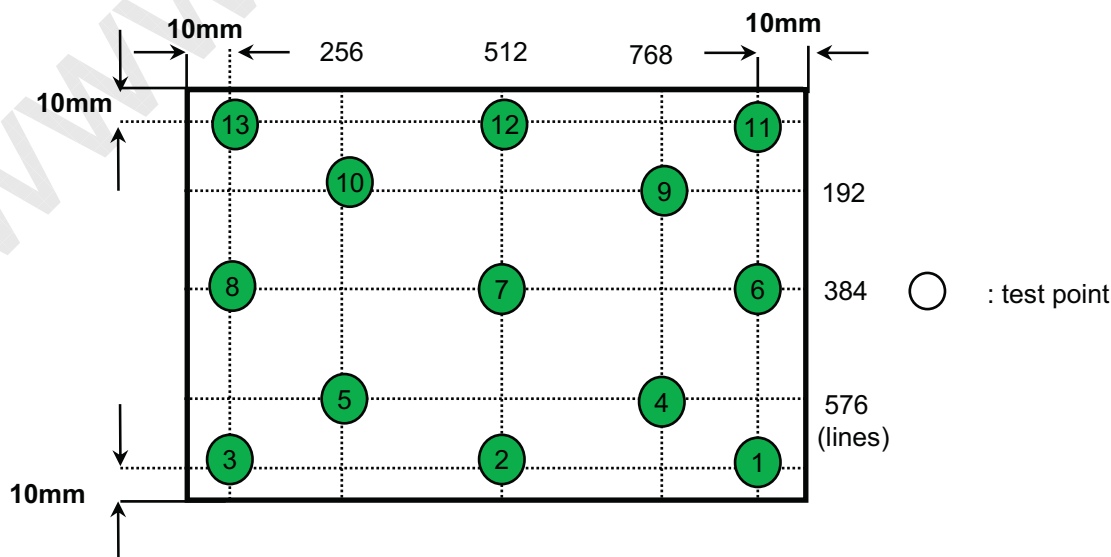

Approval

3. ELECTRICAL CHARACTERISTICS

3.1 TFT LCD MODULE

Ta=25 ± 2 °C

ITEM		SYMBOL	MIN	TYP	MAX	UNIT	NOTE
Voltage of Power Supply		V _{DD}	3.0	3.3	3.6	V	
Differential Input Voltage for LVDS Receiver Threshold	High	V _{IH}	-	-	+100	mV	V _{CM} =+1.2V
	Low	V _{IL}	-100	-	-	mV	
Vsync Frequency	60Hz	Hsync Freq	F _H	47.0	48.36	49.5	KHz
		Main Freq	F _{DCLK}	63.4	65	66.6	MHz
	50Hz	Hsync Freq	F _H	39.2	40.3	41.2	KHz
		Main Freq	F _{DCLK}	52.7	54.1	55.45	MHz
	40Hz	Hsync Freq	F _H	31.4	32.24	33.0	KHz
		Main Freq	F _{DCLK}	42.25	43.33	44.4	MHz
Rush Current		I _{RUSH}	-	-	1.5	A	(4)
Current of Power Supply	White	I _{DD}	-	270	-	mA	(2),(3)*a
	Mosaic		-	300	-	mA	(2),(3)*b
	Win98 Pattern		-	330	-	mA	(2),(3)*c
	Max Pattern		-	-	360	mA	(2),(3)*d

Note (1) Display data pins and timing signal pins should be connected.(GND=0V)

(2) f_v=60Hz, f_{DCLK} =65MHZ, V_{dd} = 3.3V , DC Current.

(3) Power dissipation pattern

*a) White Pattern

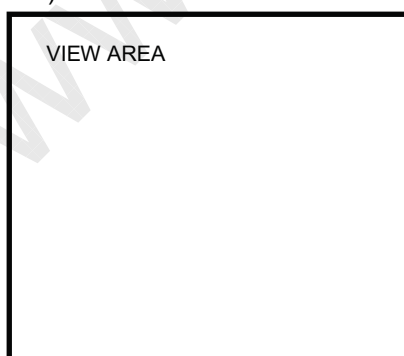

*b) Mosaic Pattern

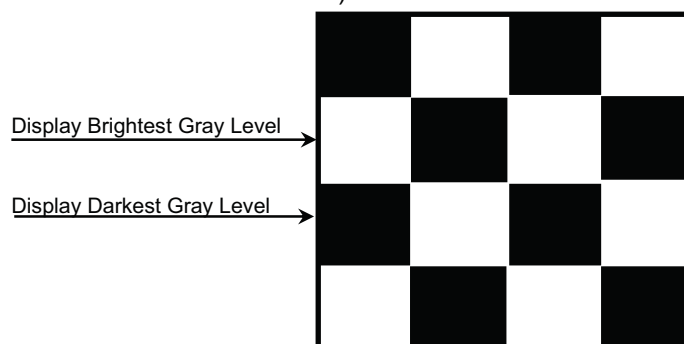

Approval

*c) Win98 Pattern (Cyan 63gray)



*d) 1dot Inversion Pattern

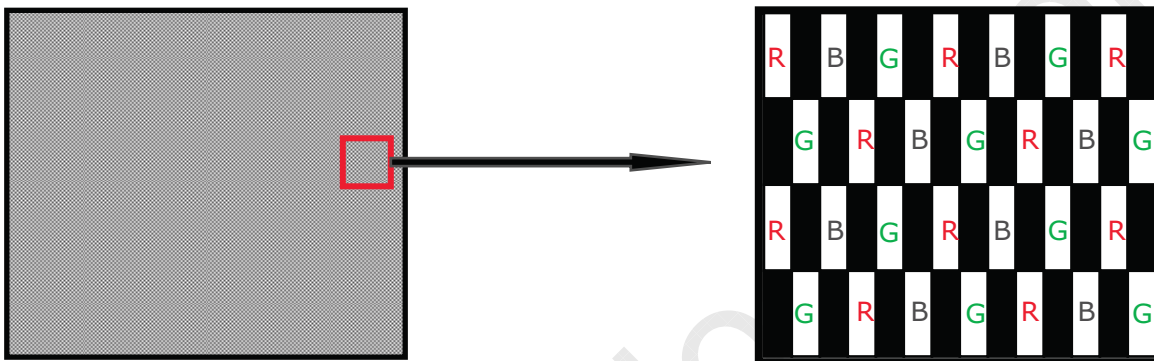

4) Rush current measurement condition

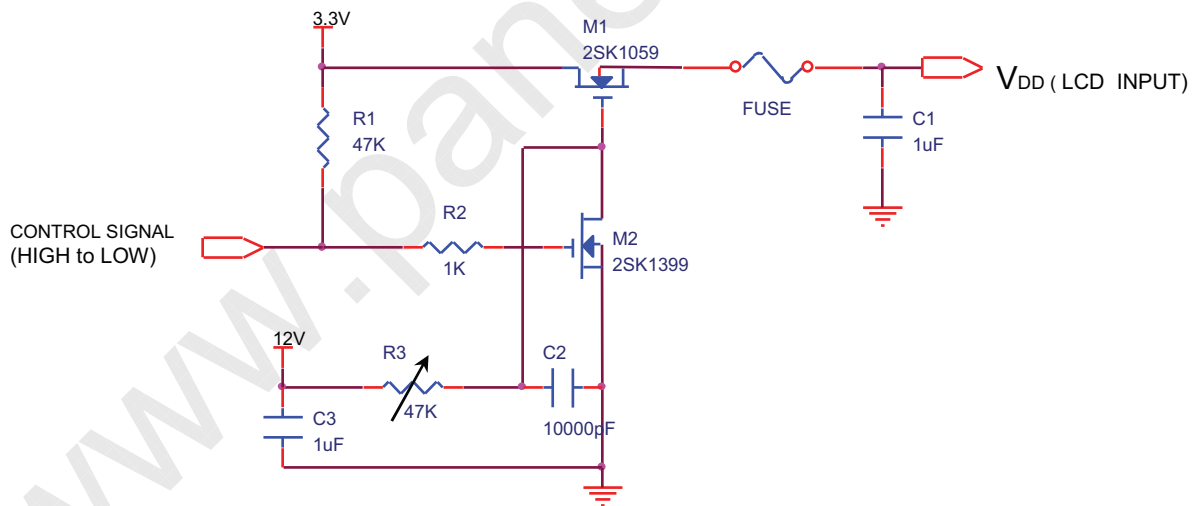

V_{DD} rising time is 470us

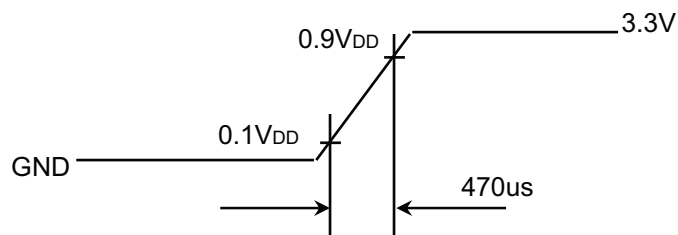

Approval

3.2 BACKLIGHT UNIT

The back-light system is an edge - lighting type with a single CCFL (Cold Cathode Fluorescent Lamp).
The characteristics of a single lamp are shown in the following tables.

CCFL P/N : MBTK18J()X255.5MWLEH/CD (HTL, UV-Cut Lamp)

Ta = 25 ± 2°C

ITEM	SYMBOL	MIN	TYP	MAX	UNIT	NOTE
Lamp Current	I _L	3.0	6.0	6.5	mArms	(1)
Lamp Voltage	V _L	520	550	580	V _{rms}	I _L =6.0mA
Frequency	f _L	50	60	70	KHz	
Power Consumption	P _L	-	3.3	3.6	W	(2) I _L =6.0mA
Operating Life Time	Hr	10,000	-	-	Hour	(3)
Startup Voltage	V _s	-	-	1200 (25°C)	V _{rms}	
				1400 (0°C)		

Note (1) Lamp current is measured with a high frequency current meter as shown below.

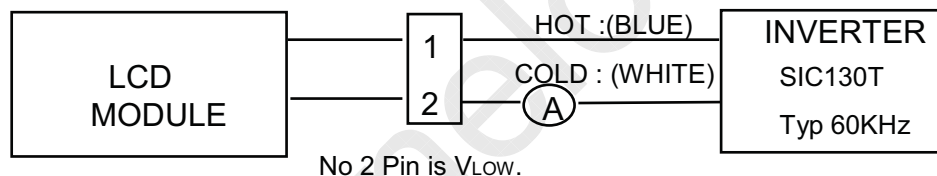

(2) The value is calculated by I_L X V_L when inverter's efficient is 85%. .

(3) Life time (Hr) of a lamp can be defined as the time in which it continues to operate under the condition Ta = 25 ± 2°C and I_L = 6.0 mArms until one of the following event occurs.

1. When the brightness becomes 50% or lower than it's original.
2. When the Effective ignition length becomes 80% or lower than it's original value.
(Effective ignition length is defined as an area that has less than 70% brightness compared to the brightness in the center point.)

(4) CCFL life is no problem over 20% duty of PWM

Approval

4. BLOCK DIAGRAM

4.1 TFT LCD MODULE

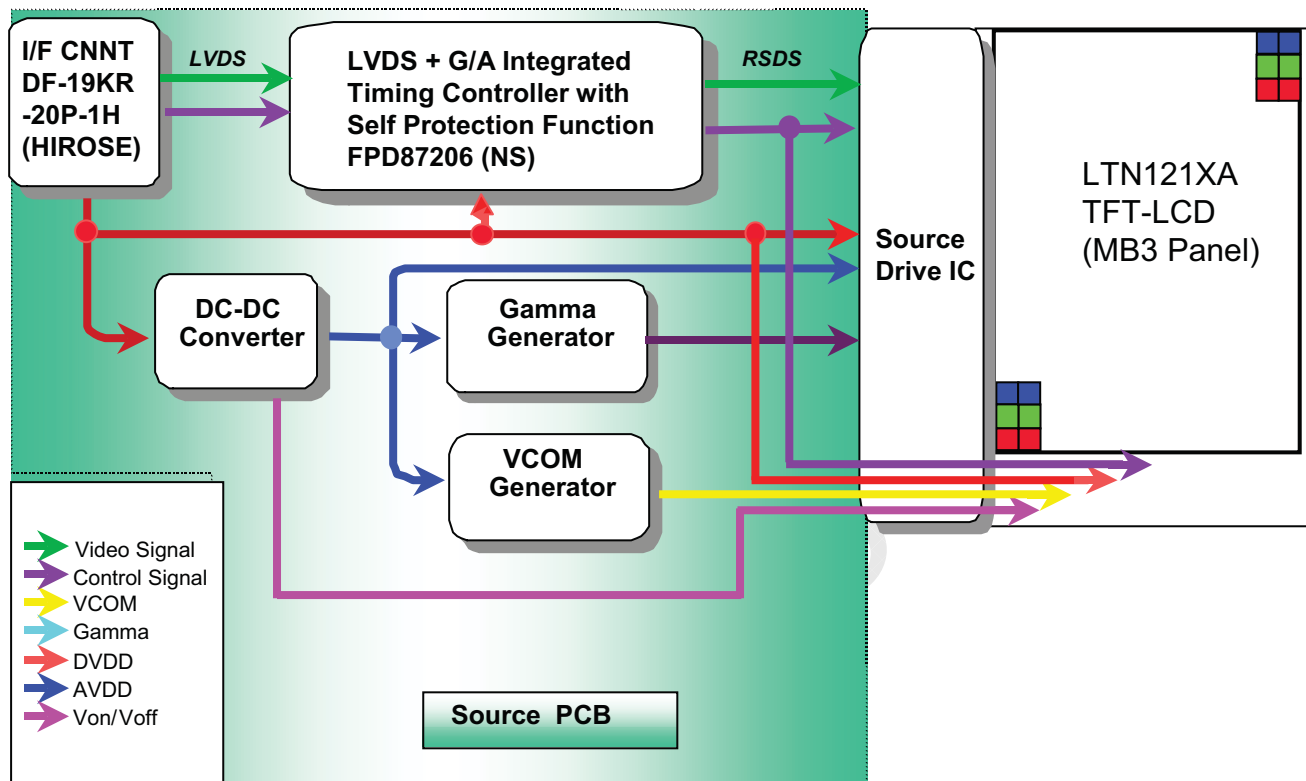

4.2 BACKLIGHT UNIT (Connector : JST, BHSR-02VS-01)

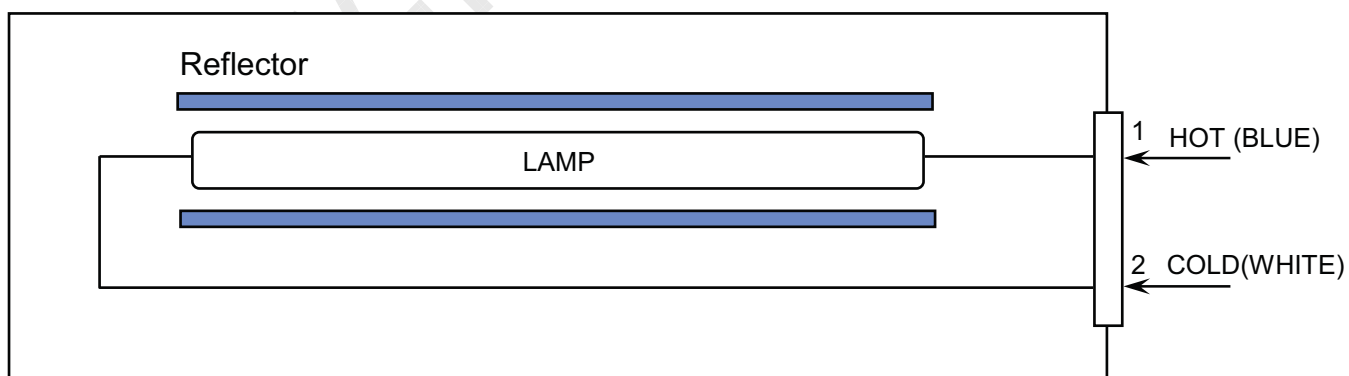

Note) The output of the inverter may change according to the material of the reflector.

Approval

5. INPUT TERMINAL PIN ASSIGNMENT

5.1. Input Signal & Power (Connector : HIROSE, DF-19KR-20P-1H
Mating Connector : HIROSE, DF19G-20S-1F)

PIN NO	SYMBOL	FUNCTION	POLARITY	REMARK
1	VDD	POWER SUPPLY +3.3V		
2	VDD	POWER SUPPLY +3.3V		
3	VSS	GROUND		
4	VSS	GROUND		
5	RxIN0-	LVDS Differential Data INPUT	Negative	R0~R5 G0
6	RxIN0+	LVDS Differential Data INPUT	Positive	
7	VSS	GROUND		
8	RxIN1-	LVDS Differential Data INPUT	Negative	G1~G5 B0~B1
9	RxIN1+	LVDS Differential Data INPUT	Positive	
10	VSS	GROUND		
11	RxIN2-	LVDS Differential Data INPUT	Negative	B2~B5 HS,VS,DE
12	RxIN2+	LVDS Differential Data INPUT	Positive	
13	VSS	GROUND		
14	ClkIN-	LVDS Differential Clock INPUT	Negative	
15	ClkIN+	LVDS Differential Clock INPUT	Positive	
16	VSS	GROUND		
17	NC	Reserved		
18	NC	Reserved		
19	VSS	GROUND		
20	VSS	GROUND		

Approval

5.2 LVDS Interface : Transmitter DS90CF383 or Compatible

Pin No.	Name	RGB Signal	Pin No.	Name	RGB Signal
51	TxIN0	R0	14	TxIN14	G5
52	TxIN1	R1	15	TxIN15	B0
54	TxIN2	R2	19	TxIN18	B1
55	TxIN3	R3	20	TxIN19	B2
56	TxIN4	R4	22	TxIN20	B3
3	TxIN6	R5	23	TxIN21	B4
4	TxIN7	G0	24	TxIN22	B5
6	TxIN8	G1	27	TxIN24	Hsync
7	TxIN9	G2	28	TxIN25	Vsync
11	TxIN12	G3	30	TxIN26	DE
12	TxIN13	G4	31	TxCLKIN	Clock

FLAT LINK INTERFACE

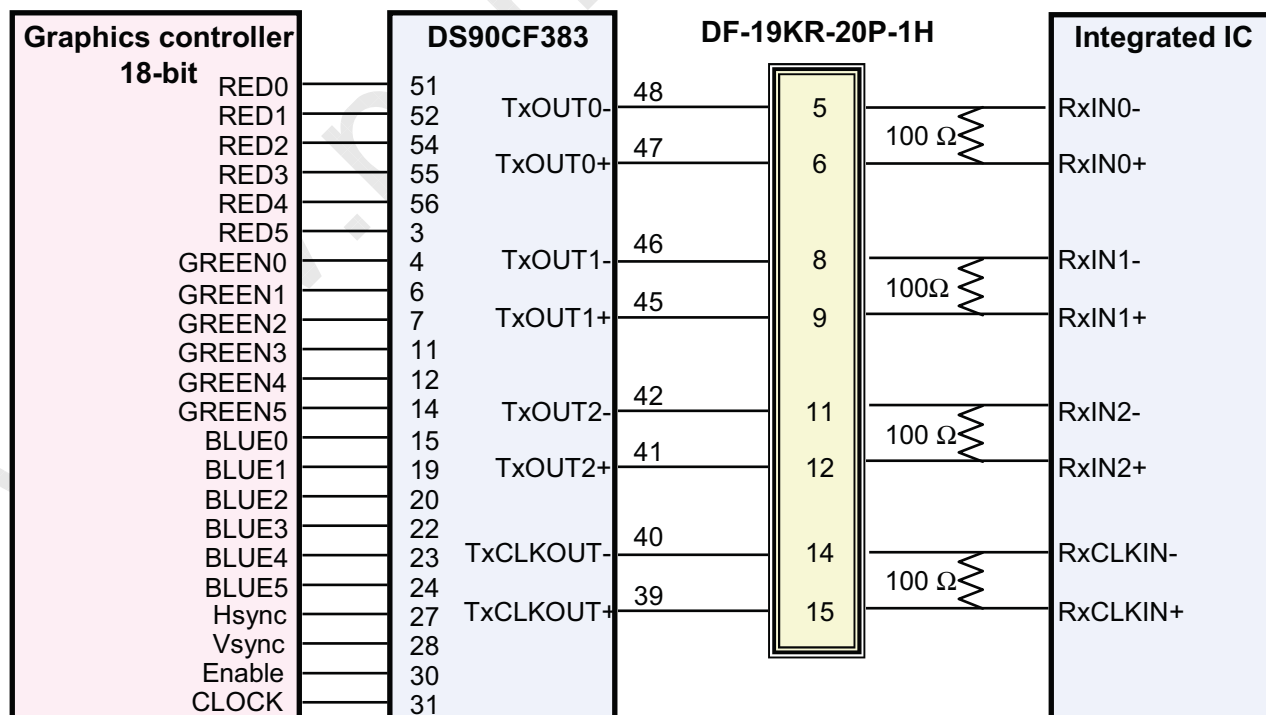

Approval

5.3 BACK LIGHT UNIT

Connector : JST, BHSR - 02VS -1
Mating Connector : JST, SM02B-BHSS-1

Pin NO.	Symbol	Color	Function
1	HOT	BLUE	High Voltage
2	COLD	WHITE	Low Voltage

5.4 Timing Diagrams of LVDS For Transmission

LVDS Receiver : FPD87206(NS)

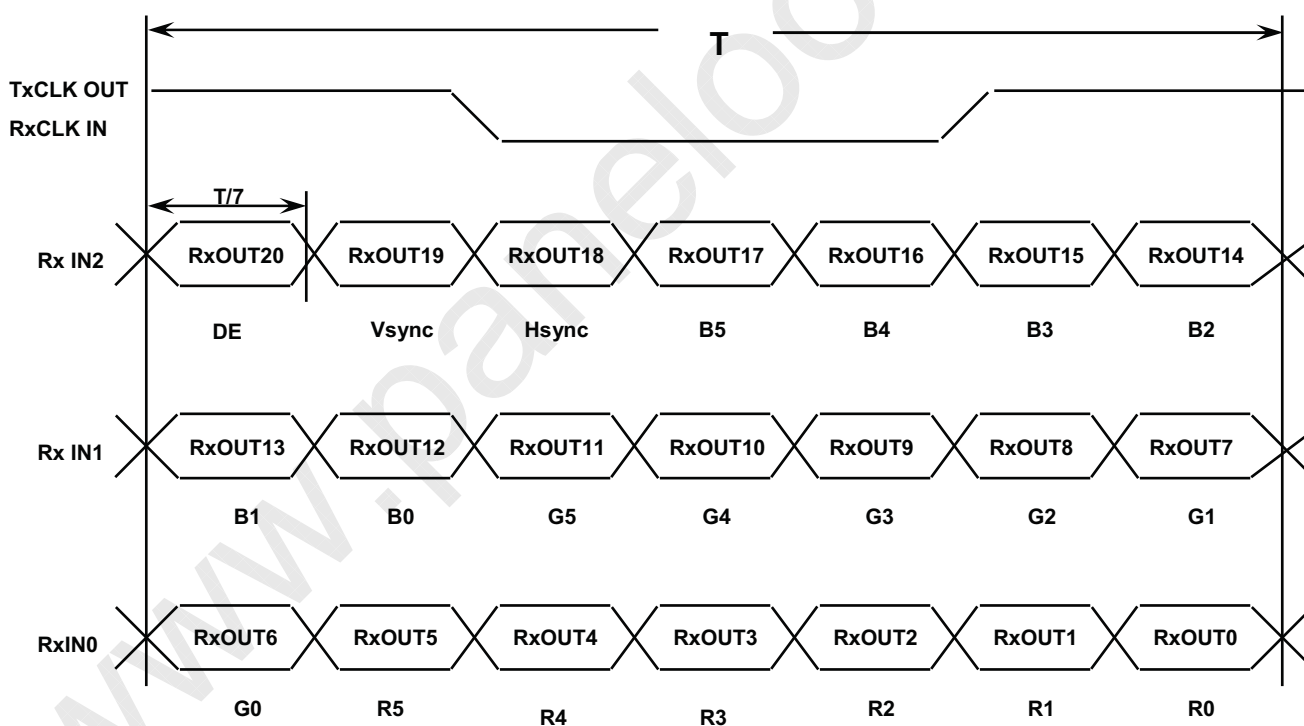

Approval

5.5 Input Signal, Basic Display Colors and Gray Scale of Each Colors

COLOR	DISPLAY	DATA SIGNAL																GRAY SCALE LEVEL	
		RED					GREEN					BLUE							
		R0	R1	R2	R3	R4	R5	G0	G1	G2	G3	G4	G5	B0	B1	B2	B3		B4
BASIC COLOR	BLACK	0	0	0	0	0	0	0	0	0	0	0	0	0	0	0	0	0	-
	BLUE	0	0	0	0	0	0	0	0	0	0	0	0	1	1	1	1	1	-
	GREEN	0	0	0	0	0	0	1	1	1	1	1	1	0	0	0	0	0	-
	CYAN	0	0	0	0	0	0	1	1	1	1	1	1	1	1	1	1	1	-
	RED	1	1	1	1	1	1	0	0	0	0	0	0	0	0	0	0	0	-
	MAGENTA	1	1	1	1	1	1	0	0	0	0	0	0	1	1	1	1	1	-
	YELLOW	1	1	1	1	1	1	1	1	1	1	1	1	0	0	0	0	0	-
	WHITE	1	1	1	1	1	1	1	1	1	1	1	1	1	1	1	1	1	-
GRAY SCALE OF RED	BLACK	0	0	0	0	0	0	0	0	0	0	0	0	0	0	0	0	R0	
	DARK ↑	1	0	0	0	0	0	0	0	0	0	0	0	0	0	0	0	0	R1
		0	1	0	0	0	0	0	0	0	0	0	0	0	0	0	0	0	R2
		:	:	:	:	:	:	:	:	:	:	:	:	:	:	:	:	:	R3~R60
	:	:	:	:	:	:	:	:	:	:	:	:	:	:	:	:	:		
	↓ LIGHT	1	0	1	1	1	1	0	0	0	0	0	0	0	0	0	0	0	R61
		0	1	1	1	1	1	0	0	0	0	0	0	0	0	0	0	0	R62
	RED	1	1	1	1	1	1	0	0	0	0	0	0	0	0	0	0	0	R63
GRAY SCALE OF GREEN	BLACK	0	0	0	0	0	0	0	0	0	0	0	0	0	0	0	0	G0	
	DARK ↑	0	0	0	0	0	0	1	0	0	0	0	0	0	0	0	0	0	G1
		0	0	0	0	0	0	0	1	0	0	0	0	0	0	0	0	0	G2
		:	:	:	:	:	:	:	:	:	:	:	:	:	:	:	:	:	G3~G60
	:	:	:	:	:	:	:	:	:	:	:	:	:	:	:	:	:		
	↓ LIGHT	0	0	0	0	0	0	1	0	1	1	1	1	0	0	0	0	0	G61
		0	0	0	0	0	0	0	1	1	1	1	1	0	0	0	0	0	G62
	GREEN	0	0	0	0	0	0	1	1	1	1	1	1	0	0	0	0	0	G63
GRAY SCALE OF BLUE	BLACK	0	0	0	0	0	0	0	0	0	0	0	0	0	0	0	0	B0	
	DARK ↑	0	0	0	0	0	0	0	0	0	0	0	0	1	0	0	0	0	B1
		0	0	0	0	0	0	0	0	0	0	0	0	0	1	0	0	0	B2
		:	:	:	:	:	:	:	:	:	:	:	:	:	:	:	:	:	B3~B60
	:	:	:	:	:	:	:	:	:	:	:	:	:	:	:	:	:		
	↓ LIGHT	0	0	0	0	0	0	0	0	0	0	0	0	1	0	1	1	1	B61
		0	0	0	0	0	0	0	0	0	0	0	0	0	1	1	1	1	B62
	BLUE	0	0	0	0	0	0	0	0	0	0	0	0	1	1	1	1	1	B63

Note

(1) Definition of Gray : Rn : Red Gray, Gn : Green Gray, Bn : Blue Gray (n = Gray level)

(2) Input Signal : 0 = Low level voltage, 1 = High level voltage

Doc.No.

LTN121XA-L01

Rev.No

04 - A05 -G - 041020

Page

18 / 27

SEC Secret

Approval

5.6 PIXEL FORMAT

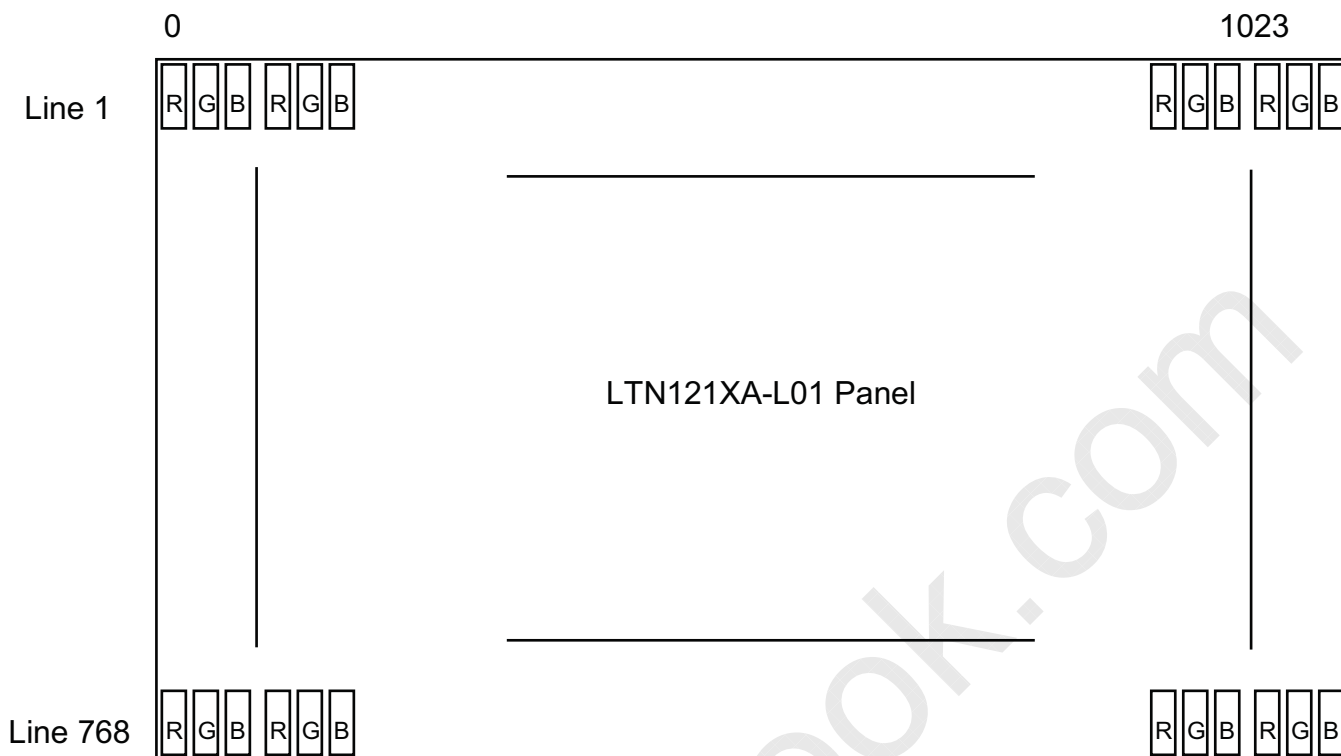

Approval

6. INTERFACE TIMING

6.1 Timing Parameters

Signal	Item	Symbol	MIN	TYP	MAX	Unit	Note
Frame Frequency	Cycle	\downarrow	772	806	1000	lines	
Vertical Active Display Term	Display Period	\downarrow_D	-	768	-	lines	
One Line Scanning Time	Cycle	\updownarrow	1072	1344	1500	clocks	
Horizontal Active Display Term	Display Period	\updownarrow_D	-	1024	-	clocks	

6.2 Timing diagrams of interface signal

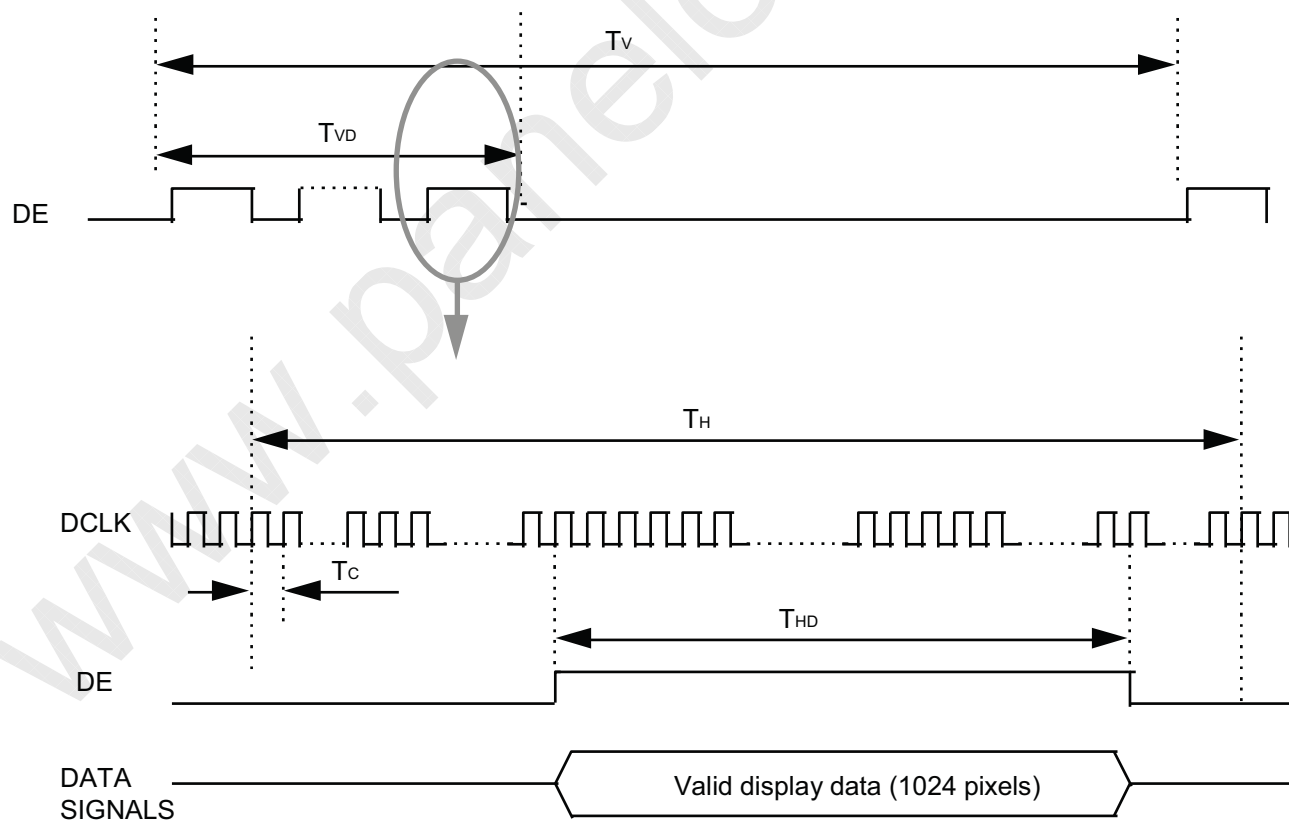

Note

(1) All input condition(level&timing) for LXD01812 are the same with those of NS DS90CF384 or compatible.

Approval

6.3 Power ON/OFF Sequence

: To prevent a latch-up or DC operation of the LCD module, the power on/off sequence shall be as shown below.

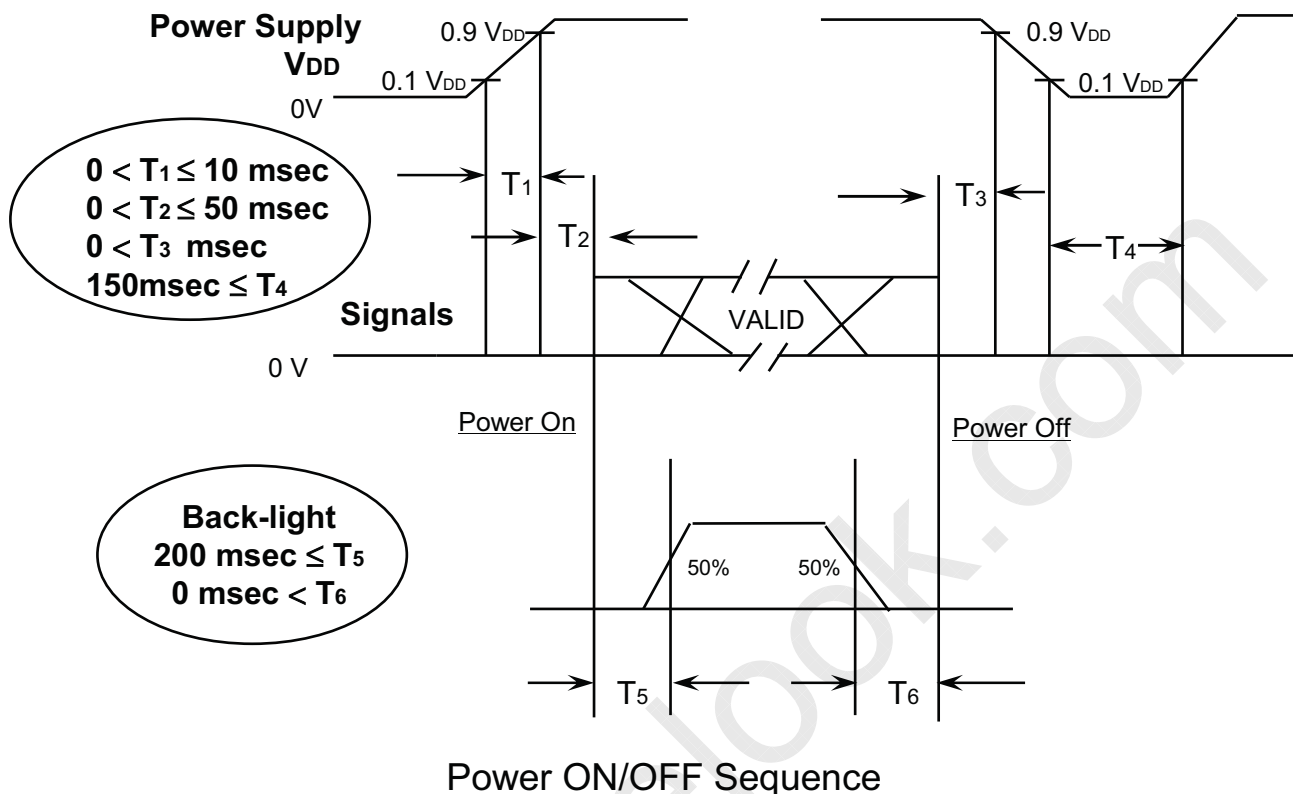

- T1 : Vdd rising time from 10% to 90%
 T2 : The time from Vdd to valid data at power ON.
 T3 : The time from valid data off to Vdd off at power Off.
 T4 : Vdd off time for Windows restart
 T5 : The time from valid data to B/L enable at power ON.
 T6 : The time from valid data off to B/L disable at power Off.

NOTE.

- (1) The supply voltage of the external system for the module input should be the same as the definition of V_{DD}.
- (2) Apply the lamp voltage within the LCD operation range. When the backlight turns on before the LCD operation or the LCD turns off before the backlight turns off, the display may momentarily become white.
- (3) In case of V_{DD} = off level, please keep the level of input signals on the low or keep a high impedance.
- (4) T₄ should be measured after the module has been fully discharged between power off and on period.
- (5) Interface signal shall not be kept at high impedance when the power is on.

7. Outline Dimension

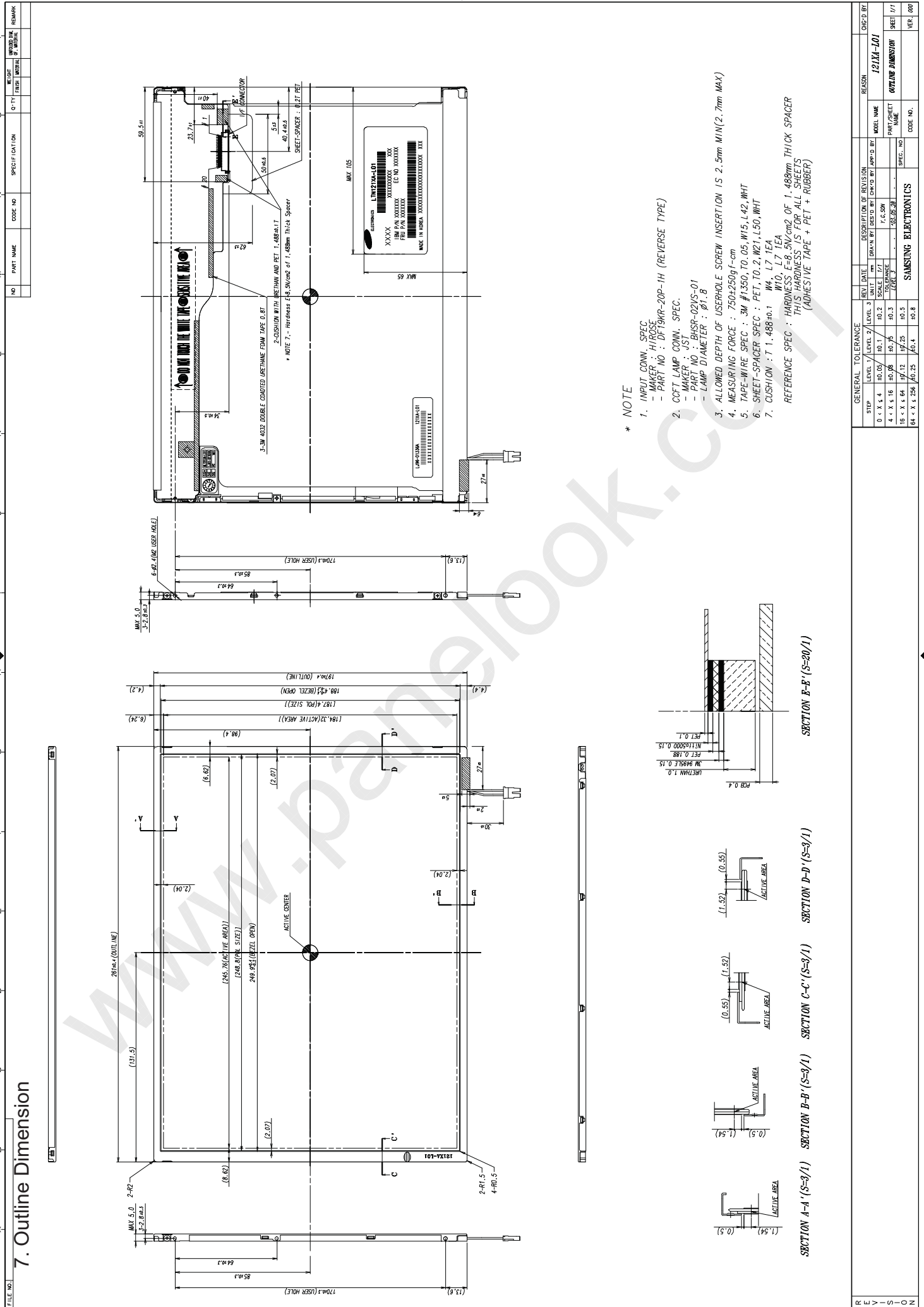

- * NOTE
- INPUT CONV. SPEC
- MAKER : HIROSE
- PART NO : DF19KR-20P-1H (REVERSE TYPE)
 - COFT LAMP CONV. SPEC.
- MAKER : JST
- PART NO : BHSR-02VS-01
- LAMP DIAMETER : $\phi 1.8$
 - ALLOWED DEPTH OF USERHOLE SCREW INSERTION IS 2.5mm MIN(2.7mm MAX)
 - MEASURING FORCE : 750 \pm 250gf-cm
 - TAPE-WIRE SPEC : 3M #1350, TO-05, W15, L42, WHT
 - SHEET-SPACER SPEC : PET, TO-2, W21, L50, WHT
 - CUSHION : T 1, 488 ± 0.1 W4, L7 1EA
- REFERENCE SPEC : HARDNESS E-8.5N/cm² OF 1.488mm THICK SPACER
THIS HARDNESS IS FOR ALL SHEETS
(ADHESIVE TAPE + PET + RUBBER)

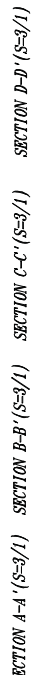
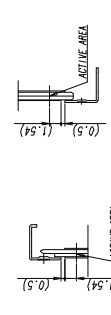
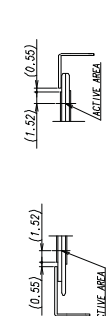
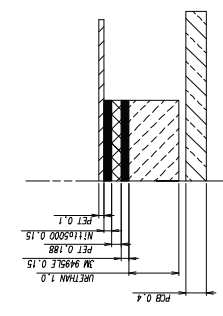

STEP	LEVEL	TOLERANCE	GENERAL TOLERANCE		DESCRIPTION OF REVISION		REASON	DATE	DRAWN BY	CHECKED BY	APPR'D BY	MODEL NAME	PART/SHEET NAME	CODE NO.	VER.
			LEVEL 1	LEVEL 2	LEVEL 3	LEVEL 4									
0	x x 4	± 0.05	± 0.1	± 0.2	1	1	1	1	1	1	1	121A-101	OUTLINE DIMENSION		009
1	x x 4	± 0.05	± 0.1	± 0.2	1	1	1	1	1	1	1	121A-101	OUTLINE DIMENSION		009
2	x x 4	± 0.05	± 0.1	± 0.2	1	1	1	1	1	1	1	121A-101	OUTLINE DIMENSION		009
3	x x 4	± 0.05	± 0.1	± 0.2	1	1	1	1	1	1	1	121A-101	OUTLINE DIMENSION		009
4	x x 4	± 0.05	± 0.1	± 0.2	1	1	1	1	1	1	1	121A-101	OUTLINE DIMENSION		009
5	x x 4	± 0.05	± 0.1	± 0.2	1	1	1	1	1	1	1	121A-101	OUTLINE DIMENSION		009
6	x x 4	± 0.05	± 0.1	± 0.2	1	1	1	1	1	1	1	121A-101	OUTLINE DIMENSION		009
7	x x 4	± 0.05	± 0.1	± 0.2	1	1	1	1	1	1	1	121A-101	OUTLINE DIMENSION		009
8	x x 4	± 0.05	± 0.1	± 0.2	1	1	1	1	1	1	1	121A-101	OUTLINE DIMENSION		009
9	x x 4	± 0.05	± 0.1	± 0.2	1	1	1	1	1	1	1	121A-101	OUTLINE DIMENSION		009
10	x x 4	± 0.05	± 0.1	± 0.2	1	1	1	1	1	1	1	121A-101	OUTLINE DIMENSION		009
11	x x 4	± 0.05	± 0.1	± 0.2	1	1	1	1	1	1	1	121A-101	OUTLINE DIMENSION		009
12	x x 4	± 0.05	± 0.1	± 0.2	1	1	1	1	1	1	1	121A-101	OUTLINE DIMENSION		009
13	x x 4	± 0.05	± 0.1	± 0.2	1	1	1	1	1	1	1	121A-101	OUTLINE DIMENSION		009
14	x x 4	± 0.05	± 0.1	± 0.2	1	1	1	1	1	1	1	121A-101	OUTLINE DIMENSION		009
15	x x 4	± 0.05	± 0.1	± 0.2	1	1	1	1	1	1	1	121A-101	OUTLINE DIMENSION		009
16	x x 4	± 0.05	± 0.1	± 0.2	1	1	1	1	1	1	1	121A-101	OUTLINE DIMENSION		009
17	x x 4	± 0.05	± 0.1	± 0.2	1	1	1	1	1	1	1	121A-101	OUTLINE DIMENSION		009
18	x x 4	± 0.05	± 0.1	± 0.2	1	1	1	1	1	1	1	121A-101	OUTLINE DIMENSION		009
19	x x 4	± 0.05	± 0.1	± 0.2	1	1	1	1	1	1	1	121A-101	OUTLINE DIMENSION		009
20	x x 4	± 0.05	± 0.1	± 0.2	1	1	1	1	1	1	1	121A-101	OUTLINE DIMENSION		009
21	x x 4	± 0.05	± 0.1	± 0.2	1	1	1	1	1	1	1	121A-101	OUTLINE DIMENSION		009
22	x x 4	± 0.05	± 0.1	± 0.2	1	1	1	1	1	1	1	121A-101	OUTLINE DIMENSION		009

8. PACKING

Approval

1. CARTON(Internal Package)

(1) Packing Form

Corrugated Cardboard box and Corrupad form as shock absorber

(2) Packing Method

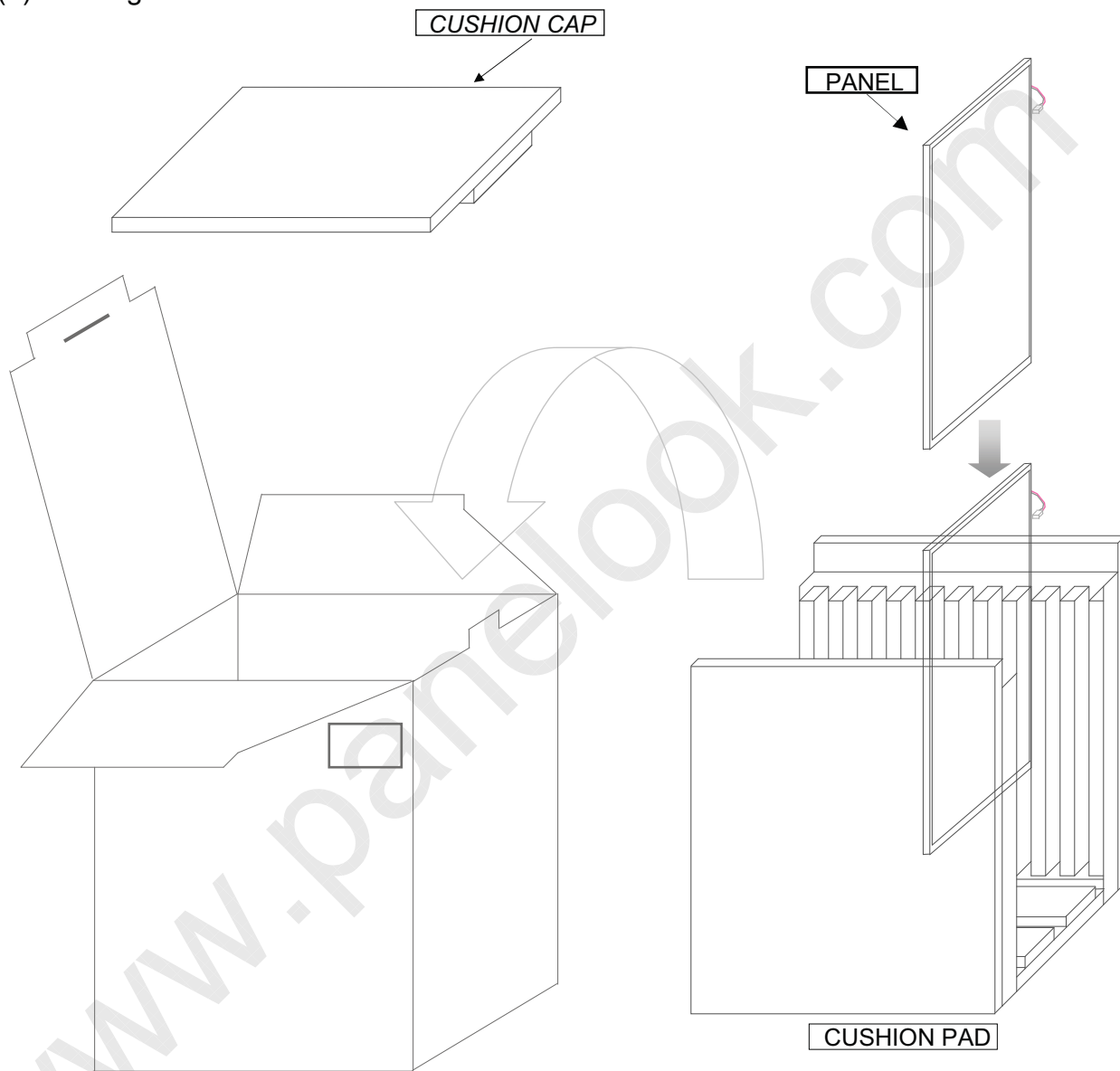

PACKING CASE

- Note 1) Total Weight : Approximately 4.4 kg
 2) Acceptance number of piling : 10 sets
 3) Carton size : 280(W) × 240(D) × 350(H)
 4) MAX accumulation quantity : 5 cartons

Approval

No	Part name	Quantity
1	Static electric protective sack	10
2	Packing case(Inner box) included shock absorber	1 set
3	Pictorial marking	2 pics
4	Carton	1 set

9. MARKINGS & OTHERS

A nameplate bearing followed by is affixed to a shipped product at the specified location on each product.

- (1)Parts number : LTN121XA-L01
- (2)Revision : One letter
- (3)Control code : One letter
- (4)Lot number : 2 F D 005 04 02

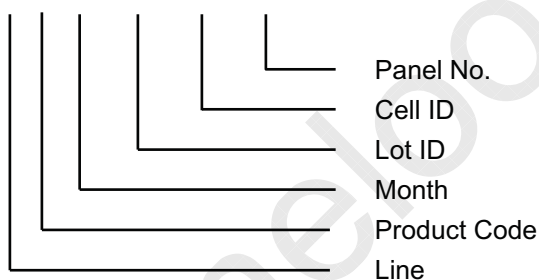

NOTE 1). This code indicating year is omitted in the products of Chun-an site.

(5) Product Label Definition



- TFT-LCD Product name : LTN121XA – L01
- Lot number : 2FD0050402
- Revision Code : 004
- Inspected work week : 0440(2004 Year, 40th week)
- IBM P/N : IBM Part Number (92P6755)
- EC NO : Engineering Change Number (Blank)
- FRU P/N : Field Replaceable Unit Part Number(92P6754)

Approval

High voltage caution label

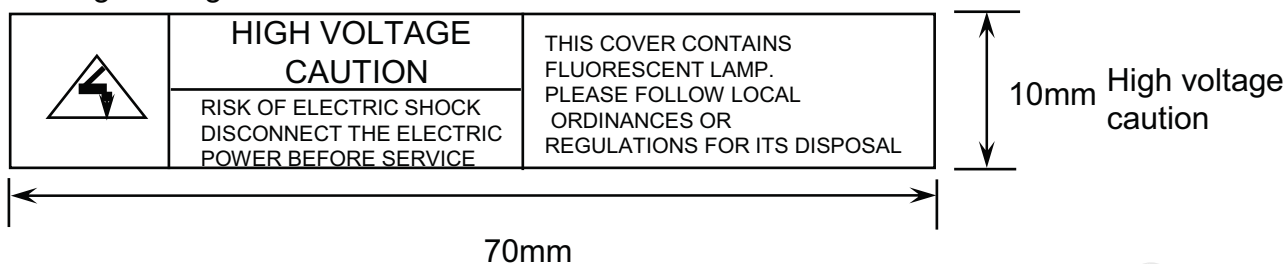

(6) Packing box attach



10. GENERAL PRECAUTIONS

1. Handling

- (a) When the module is assembled, It should be attached to the system firmly using every mounting holes. Be careful not to twist and bend the modules.
- (b) Refrain from strong mechanical shock and / or any force to the module. In addition to damage, this may cause improper operation or damage to the module and CCFT back-light.
- (c) Note that polarizers are very fragile and could be easily damaged. Do not press or scratch the surface harder than a HB pencil lead.
- (d) Wipe off water droplets or oil immediately. If you leave the droplets for a long time, Staining and discoloration may occur.
- (e) If the surface of the polarizer is dirty, clean it using some absorbent cotton or soft cloth.
- (f) The desirable cleaners are water, IPA(Isoprophyl Alcohol) or Hexane. Do not use Ketone type materials(ex. Acetone), Ethyl alcohol, Toluene, Ethyl acid or Methyl chloride. It might permanent damage to the polarizer due to chemical reaction.
- (g) If the liquid crystal material leaks from the panel, it should be kept away from the eyes or mouth. In case of contact with hands, legs or clothes, it must be washed away thoroughly with soap.
- (h) Protect the module from static, it may cause damage to the C-MOS Gate Array IC.
- (i) Use fingerstalls with soft gloves in order to keep display clean during the incoming inspection and assembly process.
- (j) Do not disassemble the module.
- (k) Do not pull or fold the lamp wire.
- (l) Do not adjust the variable resistor which is located on the back side.
- (m) Protection film for polarizer on the module shall be slowly peeled off just before use so that the electrostatic charge can be minimized.
- (n) Pins of I/F connector shall not be touched directly with bare hands.

Doc.No.	LTN121XA-L01	Rev.No	04 - A05 -G - 041020	Page	26 / 27
---------	--------------	--------	----------------------	------	---------

SEC Secret

Approval

2. STORAGE

- (a) Do not leave the module in high temperature, and high humidity for a long time.
It is highly recommended to store the module with temperature from 0 to 35 °C and relative humidity of less than 70%.
- (b) Do not store the TFT-LCD module in direct sunlight.
- (c) The module shall be stored in a dark place. It is prohibited to apply sunlight or fluorescent light during the store.

3. OPERATION

- (a) Do not connect,disconnect the module in the "Power On" condition.
- (b) Power supply should always be turned on/off by following item 6.3 " Power on/off sequence ".
- (c) Module has high frequency circuits. Sufficient suppression to the electromagnetic interference shall be done by system manufacturers. Grounding and shielding methods may be important to minimize the interference.
- (d) The cable between the back-light connector and its inverter power supply shall be a minimized length and be connected directly . The longer cable between the back-light and the inverter may cause lower luminance of lamp(CCFT) and may require higher startup voltage(Vs).

4. OTHERS

- (a) Ultra-violet ray filter is necessary for outdoor operation.
- (b) Avoid condensation of water. It may result in improper operation or disconnection of electrode.
- (c) Do not exceed the absolute maximum rating value. (the supply voltage variation, input voltage variation, variation in part contents and environmental temperature, so on)
Otherwise the module may be damaged.
- (d) If the module displays the same pattern continuously for a long period of time,it can be the situation when the image "sticks" to the screen.
- (e) This module has its circuitry PCB's on the rear side and should be handled carefully in order not to be stressed.

Doc.No.	LTN121XA-L01	Rev.No	04 - A05 -G - 041020	Page	27 / 27
---------	--------------	--------	----------------------	------	---------

SEC Secret