

SAMSUNG

ELECTRONICS

Approval



TO :

DATE :

SAMSUNG TFT-LCD

MODEL NO.: LTN121XP01-001

NOTE : Green product (Complied with RoHS requirement)
PVA mode (Normally Black)
Surface type [Anti-Glare]

Any Modification of Spec is not allowed without SEC' permission

APPROVED BY : *W. B. Youn*

PREPARED BY : LCD Development Team3

SAMSUNG ELECTRONICS CO., LTD.



Doc.No.	LTN121XP01-001	Rev.No	07-A00-S-070702	Page	1 / 31
---------	----------------	--------	-----------------	------	--------

CONTENTS

Revision History	----- (2)
General Description	----- (3)
1. Absolute Maximum Ratings	----- (4)
1.1 Absolute Ratings of environment	
1.2 Electrical Absolute Ratings	
2. Optical Characteristics	----- (6)
3. Electrical Characteristics	----- (10)
3.1 TFT LCD Module	
3.2 Backlight Unit	
4. Block Diagram	----- (13)
4.1 TFT LCD Module	
4.2 Backlight Unit	
5. Input Terminal Pin Assignment	----- (14)
5.1 Input Signal & Power	
5.2 LVDS Interface	
5.3 Backlight Unit	
5.4 Timing Diagrams of LVDS For Transmitting	
5.5 Input Signals, Basic Display Colors and Gray Scale of Each Color.	
5.6 Pixel format	
6. Interface Timing	----- (20)
6.1 Timing Parameters(DE Mode)	
6.2 Timing Diagrams of interface Signal (DE Mode)	
6.3 Power ON/OFF Sequence	
7. Outline Dimension	----- (22)
8. Packing	----- (24)
9. Product Marking & Others	----- (26)
10.General Precautions	----- (27)
11. EDID	----- (29)

REVISION HISTORY

Approval

Date	Revision No.	Page	Summary
March 23, 2007	P00	All	LTN121XP01-001 Model spec was issued first.
March 24, 2007	P01	13	Lamp voltage was changed as below. [AS-IS] 565 [Vrms] → [TO-BE] 580 [Vrms]
May 24, 2007	P02	5 7 15, 17 21	Humidity range is changed. .20% ~ 90% @operation → 8% ~ 95% @operation. .5% ~ 90% @storage → 5% ~ 95% @storage. White chromaticity is changed. .Typ (0.313, 0.329) → Typ (0.318, 0.334) Deletion [or compatible] .DF-19L-20P-1H(Hirose) or compatible → DF-19L-20P-1H(Hirose) .BHSR - 02VS -01 or compatible → BHSR - 02VS -01 Power ON/OFF SEQUENCE . $0 < T3 \leq 50 \text{ msec}$ → $0 < T3$
June 26, 2007	A00	23	T/C bezel at the bottom is increased vertically by 0.5mm to improve bottom light leakage. .Vertical bezel opening: $189.0 \pm 0.5 \text{ mm}$ → $188.5 \pm 0.5 \text{ mm}$.

GENERAL DESCRIPTION

DESCRIPTION

LTN121XP01-001 is a color active matrix TFT (Thin Film Transistor) liquid crystal display (LCD) that uses amorphous silicon TFT as a switching devices. This model is composed of a TFT LCD panel, a driver circuit and a backlight system. The resolution of a 12.1" contains 1024 X 768 pixels and can display up to 262,144 colors. 6 O'clock direction is the Optimum viewing angle.

FEATURES

- Wide viewing angle
- High contrast ratio
- XGA (1024X768 pixels) resolution
- Low power consumption
- DE (Data enable) only mode.
- LVDS Interface with 1 pixel / clock (1 channel)
- Auto-Recovery Function

APPLICATIONS

- Tablet PC
- Display terminals for AV application products
- If the usage of this product is not for PC application, but for others, please contact SEC

GENERAL INFORMATION

ITEM	SPECIFICATION	UNIT	NOTE
Display area	245.76(H)X184.32(V) (12.1"diagonal)	mm	
Driver element	a-si TFT active matrix		
Display colors	262,144		
Number of pixel	1024 x 768 (XGA)	pixel	
Pixel arrangement	RGB vertical stripe	mm	
Pixel pitch	0.240(H) x 0.240(V)		
Display Mode	Normally Black		
Surface treatment	HAZE 40, HARD-COATING 2H SL6		

Mechanical Information

ITEM		MIN.	TYP.	MAX.	NOTE
Module size	Horizontal (H)	260.7	261.0	261.3	
	Vertical (V)	198.5	199.0	199.5	
	Depth (D)	-	6.7	7.0	
Weight			305g	320g	

1. ABSOLUTE MAXIMUM RATINGS

1.1 ENVIRONMENTAL ABSOLUTE RATINGS

Item	Symbol	Min.	Max.	Unit	Note
Storage temperate	T_{STG}	-20	60	°C	(1)
Operating temperate (Temperature of glass surface)	T_{OPR}	0	50	°C	(1)
Shock (non-operating)	Snop	-	210	G	(2),(5)
			50		(3),(5)
Vibration (non-operating)	Vnop	-	2.41	G	(4),(5)

Note (1) Temperature and relative humidity range are shown in the figure below.

95 % RH Max. ($40\text{ }^{\circ}\text{C} \geq T_a$)

Maximum wet - bulb temperature at $39\text{ }^{\circ}\text{C}$ or less. ($T_a > 40\text{ }^{\circ}\text{C}$) No condensation.

(2) 3ms, half sine wave, one time for $\pm X, \pm Y, \pm Z$.

(3) 18ms, Trapezoidal wave, one time for $\pm X, \pm Y, \pm Z$.

(4) 5~500 Hz, Random vibration, 30 min for X,Y,Z.

(5) At testing Vibration and Shock, the fixture in holding the Module to be tested have to be hard and rigid enough so that the Module would not be twisted or bent by the fixture.

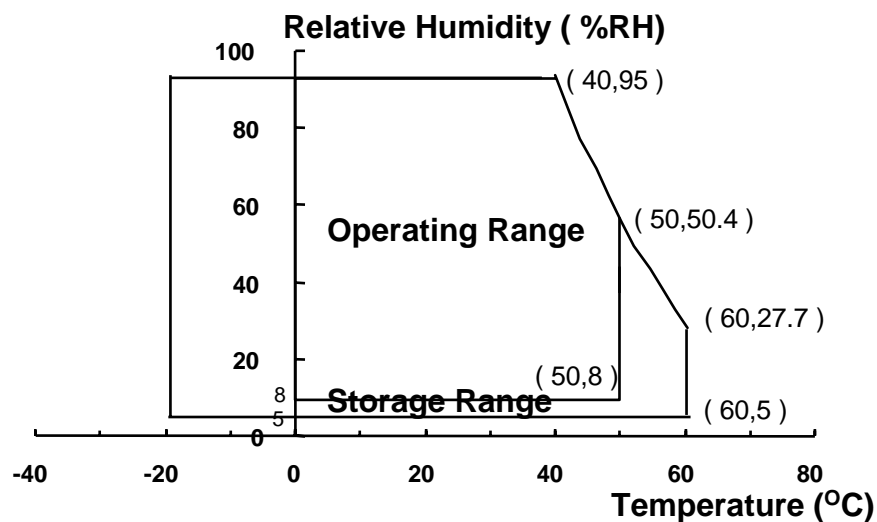

1.2 ELECTRICAL ABSOLUTE RATINGS

(1) TFT LCD MODULE

($V_{CC}=3.3$, $V_{DD}=2.5V$, $V_{SS} = GND = 0 V$)

ITEM	SYMBOL	MIN.	MAX.	UNIT	NOTE
Power Supply Voltage	V_{CC}	$V_{CC}-0.3$	$V_{CC} + 0.3$	V	(1)
Logic Input Voltage	V_{IN}	$V_{DD}-0.3$	$V_{DD} + 0.3$	V	(1)

NOTE (1) Within T_a ($25 \pm 2 \text{ }^\circ\text{C}$)

(2) BACK-LIGHT UNIT

 $T_a = 25 \pm 2 \text{ }^\circ\text{C}$

ITEM	SYMBOL	MIN.	MAX.	UNIT.	NOTE
Lamp current	I_L	2.0	7.0	mArms	(1)
Lamp frequency	F_L	50	80	KHz	(1)

NOTE (1) Permanent damage to the device may occur if maximum values are exceeded.
Functional operation should be restricted to the conditions described under Normal Operating Conditions.

2. OPTICAL CHARACTERISTICS

The following items are measured under stable conditions. The optical characteristics should be measured in a dark room or equivalent state with the methods shown in Note (5).

Measuring equipment : SR-3

* Ta = 25 ± 2°C , VDD=3.3V, fv= 50Hz, fDCLK=89.97MHz, IL = 5.5 mA

ITEM	SYMBOL	CONDITION	MIN.	TYP.	MAX.	UNIT	NOTE
Contrast Ratio (5 Points)	CR		-	500	-		
Response Time at 25°C	Rising	T _R	-	10	10	msec	(1), (3)
	Falling	T _F	-	15	25		
Luminance of White (Center)	Y _L		165	195	-	cd/m ²	(1), (4)
Color Chromaticity (CIE)	Red	R _X	φ = 0, θ = 0 Normal Viewing Angle	0.560	0.590	0.620	(1), (5)
		R _Y		0.312	0.342	0.372	
	Green	G _X		0.289	0.319	0.349	
		G _Y		0.510	0.540	0.570	
	Blue	B _X		0.122	0.152	0.182	
		B _Y		0.107	0.137	0.167	
	White	W _X		0.290	0.318	0.346	
		W _Y		0.314	0.334	0.354	
Viewing Angle	Hor.	θ _L	CR ≥ 10 (at center point)	-	85	-	Degrees
		θ _R		-	85	-	
	Ver.	φ _H		-	85	-	
		φ _L		-	85	-	
13 Points White Variation	%		65	-	-	(6)	
5 Points White Variation	%		80	-	-	(7)	

Note 1) Definition of Viewing Angle : Viewing angle range ($10 \leq C/R$ at center point)

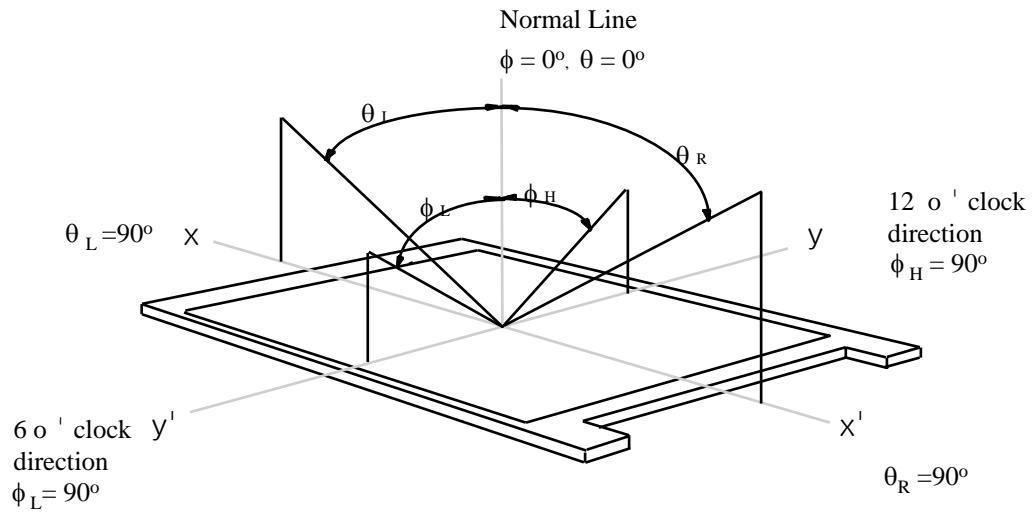

Note 2) Definition of Contrast Ratio (CR) : Ratio of gray max (Gmax) ,gray min (Gmin) at 5 points(1, 3, 5, 7, 9)

$$CR = \frac{CR(1) + CR(3) + CR(5) + CR(7) + CR(9)}{5}$$

POINTS: (1), (3), (5), (7), (9) at FIGURE OF NOTE 6)

Note 3) Definition of Response time : Sum of T_R, T_F

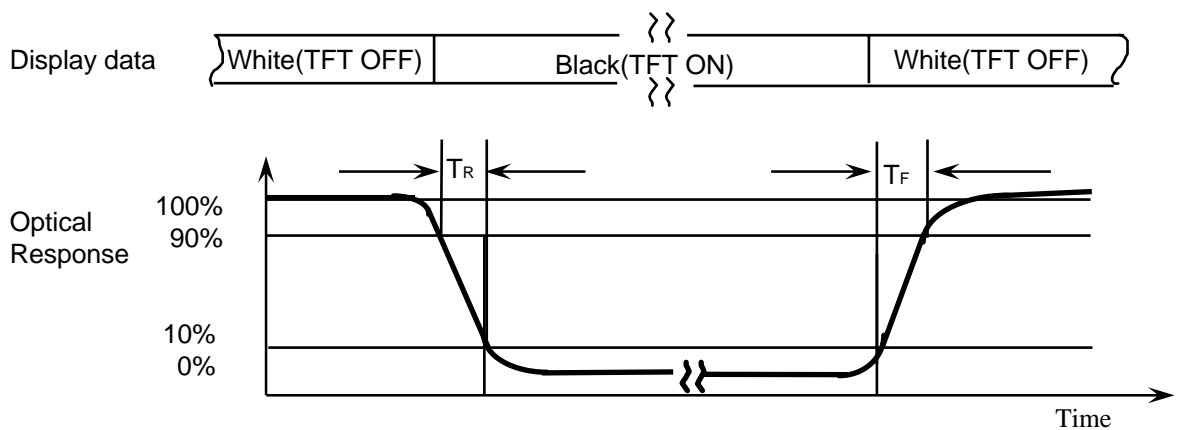

Note 4) Definition of Luminance of White : measure the luminance of white at center points.

Luminance of White (Y_L)
 Measuring Lamp Current is 5.5mA

$$Y_L = Y_{L5}$$

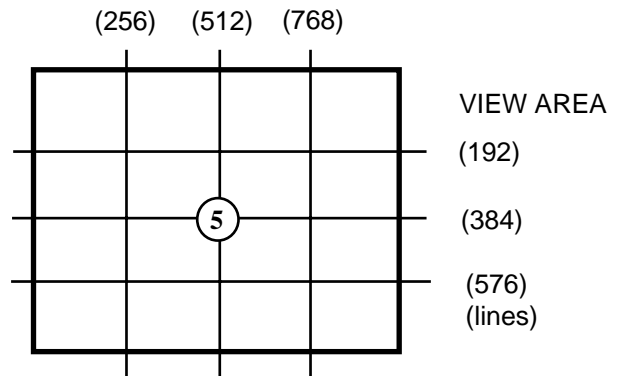

Note 5) After stabilizing and leaving the panel alone at a given temperature for 30 min , the measurement should be executed. Measurement should be executed in a stable, windless, and dark room. 30 min after lighting the back-light. This should be measured in the center of screen.
 Lamp current : 5.5mA
 Environment condition : $T_a = 25^{\circ}\text{C} \pm 2^{\circ}\text{C}$

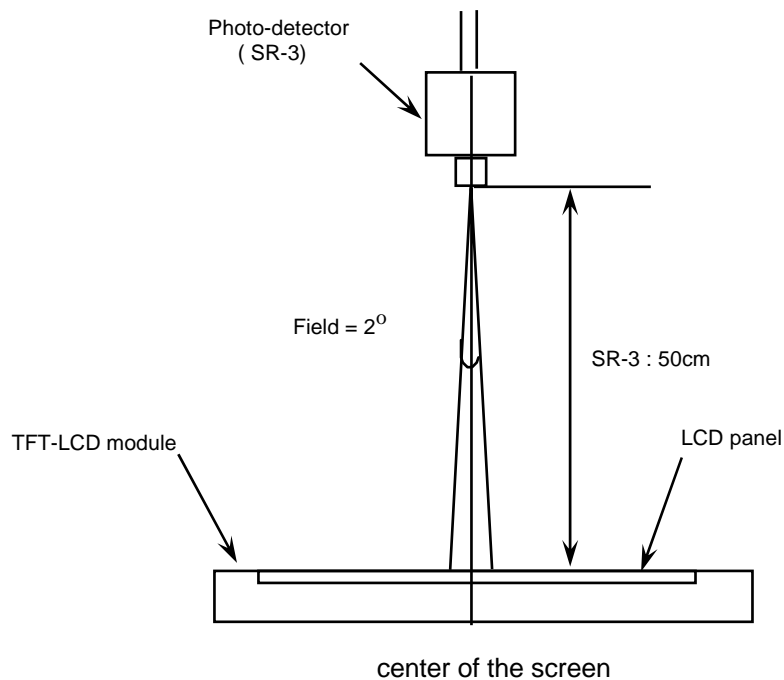

Optical characteristics measurement setup

Note 6) Definition of 13 points white variation, CR variation(C_{VER}) [① ~ ⑬]

$$\text{13 points white variation (\%)} = \frac{\text{Minimum luminance of 13 points}}{\text{Maximum luminance of 13 points}} \times 100$$

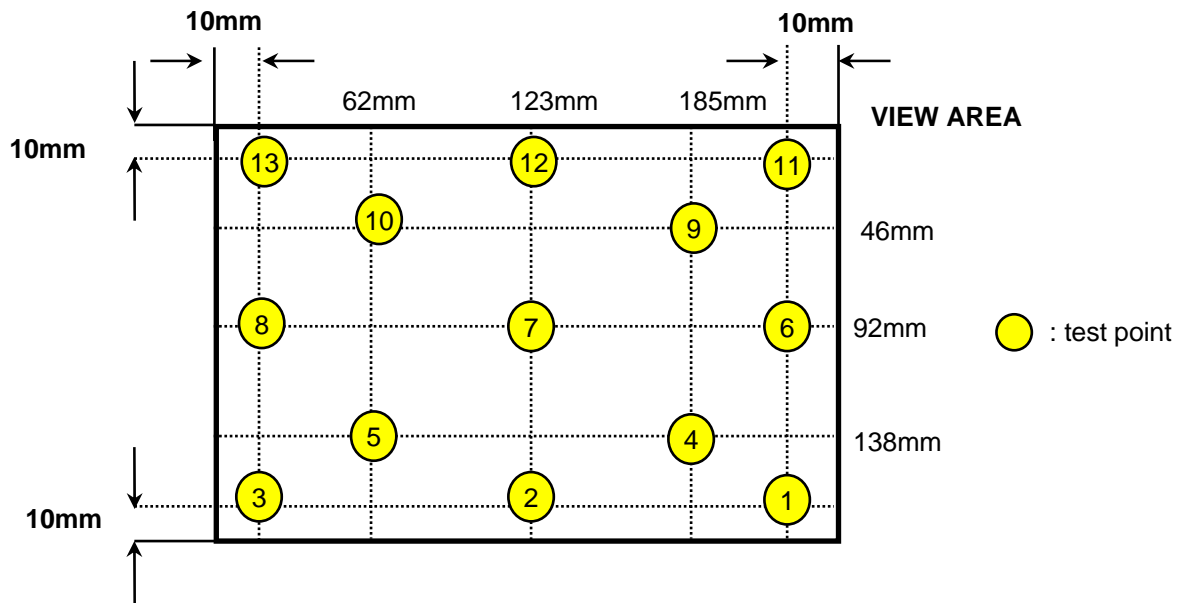

Note 7) Definition of 5 points white variation, CR variation(C_{VER}) [4,5,7,9,10]

$$\text{5 points white variation (\%)} = \frac{\text{Minimum luminance of 5 points}}{\text{Maximum luminance of 5 points}} \times 100$$

3. ELECTRICAL CHARACTERISTICS

Approval

3.1 TFT LCD MODULE

Ta=25 ± 2 °C

Item	Symbol	Min.	Typ.	Max.	Unit	Note	
Voltage of Power Supply	V _{DD}	3.0	3.3	3.6	V		
Differential Input Voltage for LVDS Receiver Threshold	High	V _{IH}	-	-	+100	mV	V _{CM} = +1.2V
	Low	V _{IL}	-100	-	-	mV	
Vsync Frequency	f _V	-	60	-	Hz		
Hsync Frequency	f _H	-	48.36	-	KHz		
Main Frequency	f _{DCLK}	63.2	64.99	69.6	MHz		
Rush Current	I _{RUSH}	-	-	1.5	A	(4)	
Current of Power Supply	Black	I _{DD}	-	270	-	mA	(2),(3)*a
	Mosaic		-	300	-	mA	(2),(3)*b
	WinXP pattern		-	275	-	mA	(2),(3)*b
	Max pattern		-	330	360	mA	(2),(3)*c

Note (1) Display data pins and timing signal pins should be connected.(GND=0V)

(2) f_V=60Hz, f_{DCLK} =64.99MHZ, V_{DD} = 3.3V , DC Current.

(3) Power dissipation pattern

*a) White Pattern

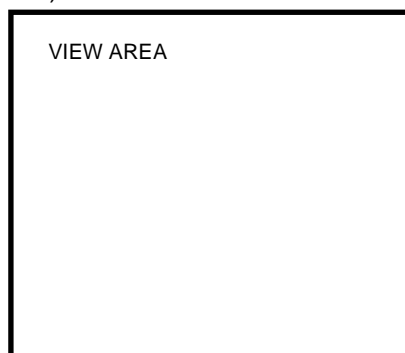

*b) Mosaic Pattern

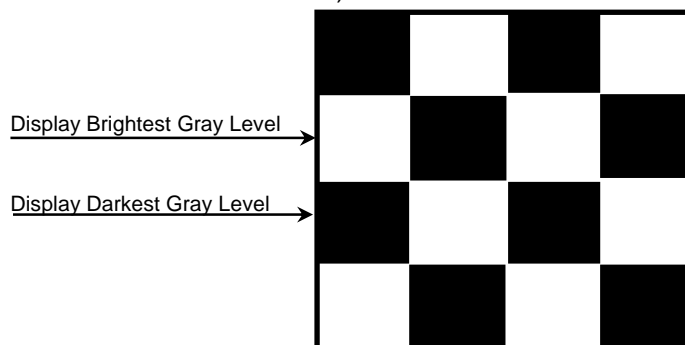

*c) 1dot Inversion Pattern (63/0 gray)

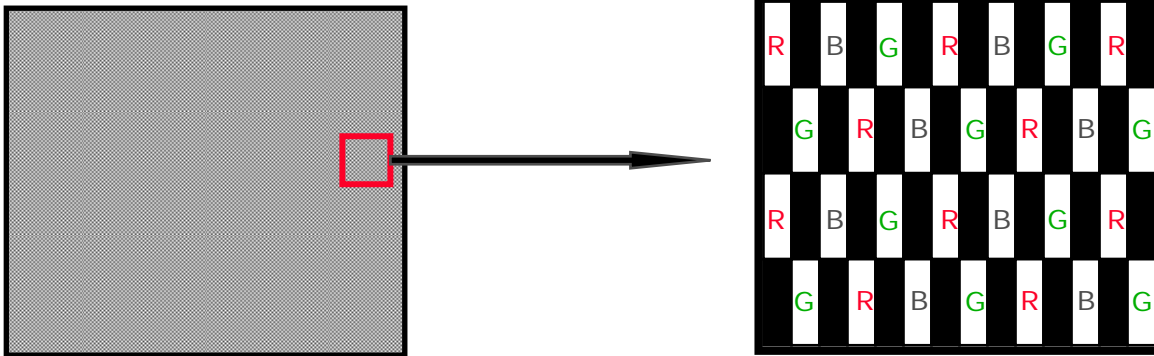

4) Rush current measurement condition

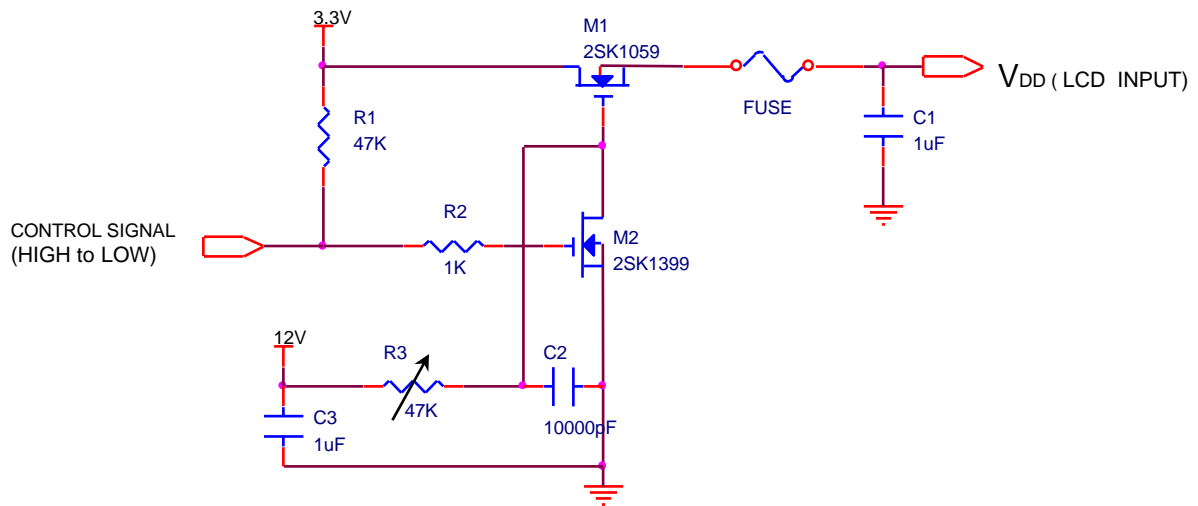

V_{DD} rising time is 470us

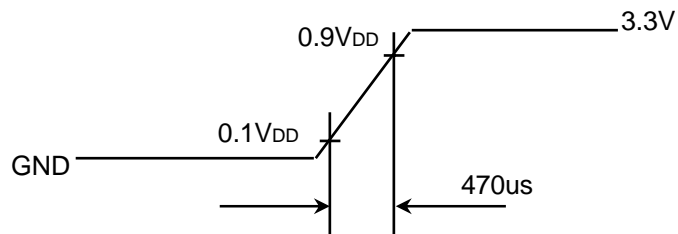

3.2 BACK-LIGHT UNIT

The backlight system is an edge - lighting type with a single CCFT (Cold Cathode Fluorescent Tube).
The characteristics of a single lamp are shown in the following tables.

INVERTER : SEM, SIC130T

LAMP : Sanken Electric , P/N: SS18C2555N6575C2662300

Ta=25 ± 2 °C

ITEM	SYMBOL	MIN	TYP	MAX	UNIT	NOTE
Lamp Current	I _L	3.0 or Duty 20%	5.5	6.5	mArms	(1)
Lamp Voltage	V _L		580		V _{rms}	I _L =5.5mA
Frequency	f _L	50	60	65	kHz	(2)
Power Consumption	P _L	-	3.2	3.5	W	(3)
Operating Life Time	H _r	12,000	-	-	Hour	(4)
Startup Voltage	V _s	-	-	865 (25°C)	V _{rms}	(5)
				1040 (0 °C)		

Note) The waveform of the inverter output voltage must be area symmetric and the design of the inverter must have specifications for the modularized lamp.

The performance of the backlight, for example life time or brightness, is much influenced by the characteristics of the DC-AC inverter for the lamp. So all the parameters of an inverter should be carefully designed so as not to produce too much leakage current from high-voltage output of the inverter.

When you design or order the inverter, please make sure that a poor lighting caused by the mismatch of the backlight and the inverter(miss lighting, flicker, etc.) never occur. When you confirm it, the module should be operated in the same condition as it is installed in your instrument.

Note (1) Lamp current is measured with a high frequency current meter as shown below.

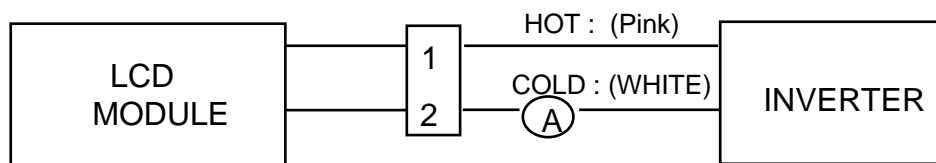

SEM SIC130T

SIC130T Inverter Switching Frequency : Typ 60KHz

(2) Lamp frequency may produce interference with horizontal synchronous frequency and this may cause line flow on the display. Therefore lamp frequency should be detached from the horizontal synchronous frequency and its harmonics as far as possible in order to avoid interference.

(3) refer to I_L × V_L to calculate.

(4) Life time (Hr) of a lamp can be defined as the time in which it continues to operate under the condition Ta = 25 ± 2 °C and I_L = 5.5 mArms until one of the following event occurs.

1. When the brightness becomes 50% or lower than the original.

(5) The voltage above this value should be applied to the lamp for more than 1 second to startup. Otherwise the lamp may not be turned on.

4. BLOCK DIAGRAM

4.1 TFT LCD Module

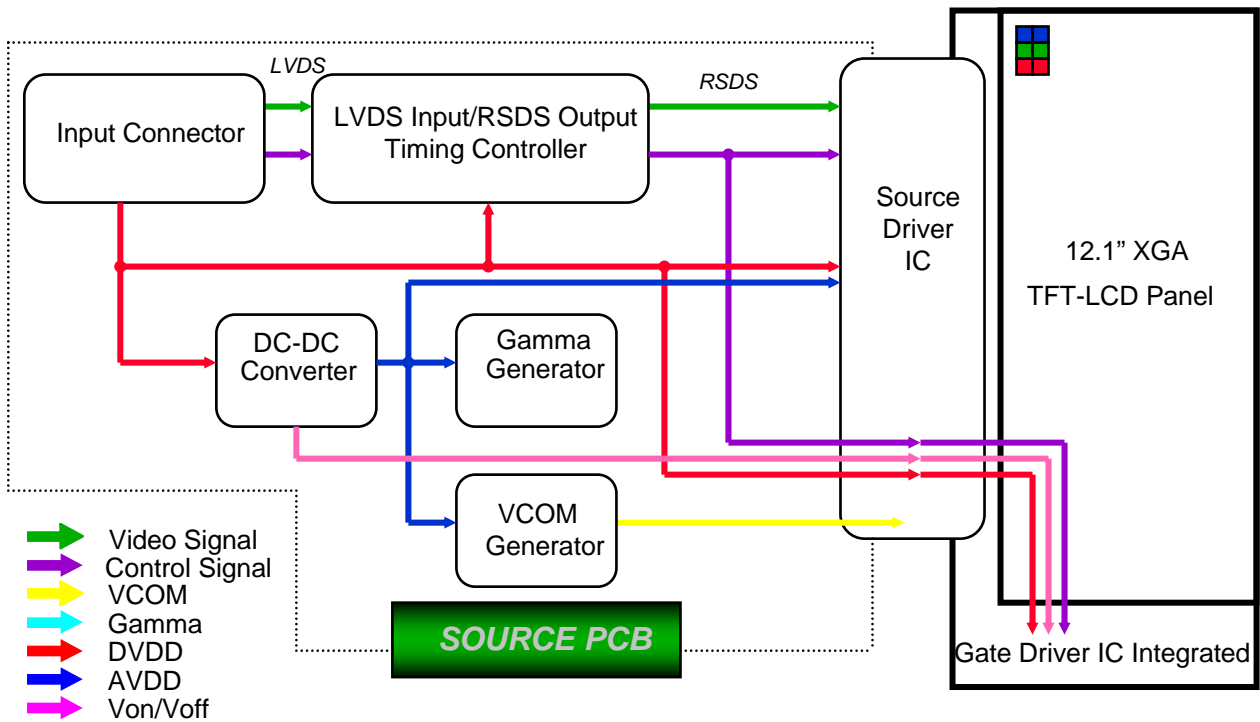

4.2 BACK-LIGHT UNIT

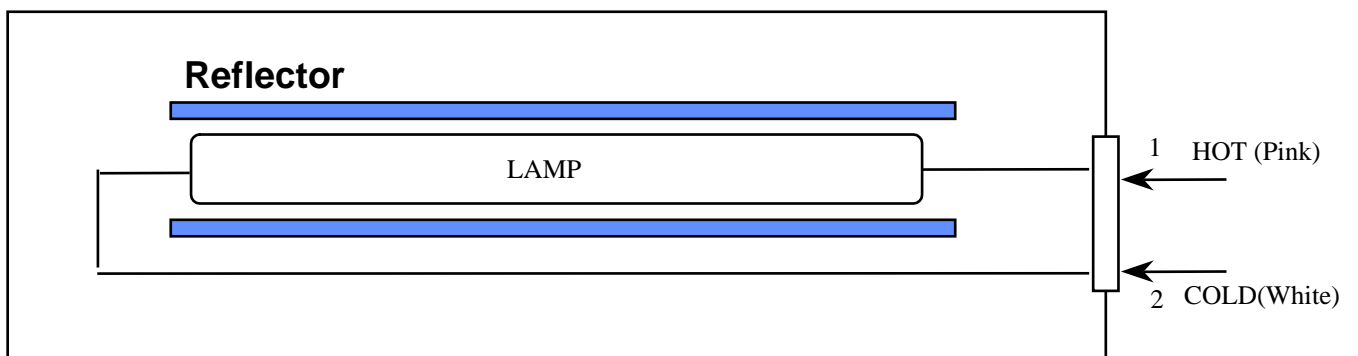

Note) The output of the inverter may change according to the material of the reflector.

5. INPUT TERMINAL PIN ASSIGNMENT

5.1. Input Signal & Power LVDS, Connector : DF-19L-20P-1H(Hirose)

Pin#	Signal Name	Function
1	VDD	Power Supply, 3.3V (Typical)
2	VDD	Power Supply, 3.3V (Typical)
3	GND	Ground
4	GND	Ground
5	Rin0-	Negative LVDS differential data input (pixel R0-R5, G0)
6	Rin0+	Positive LVDS differential data input (pixel R0-R5, G0)
7	GND	Ground
8	Rin1-	Negative LVDS differential data input (pixel G1-G5, B0-B1)
9	Rin1+	Positive LVDS differential data input (pixel G1-G5, B0-B1)
10	GND	Ground
11	Rin2-	Negative LVDS differential data input (pixel B2-B5, HS, VS, DE)
12	Rin2+	Positive LVDS differential data input (pixel B2-B5, HS, VS, DE)
13	GND	Ground
14	CLK-	Clock Signal (-)
15	CLK+	Clock Signal (+)
16	GND	Ground
17	EDID 3.3V	EDID 3.3V
18	NC	NC
19	EDID Clk	EDID Clk
20	EDID Data	EDID Data

5.2 LVDS Interface : Transmitter DS90CF363 or Compatible

Pin No.	Name	RGB Signal	Pin No.	Name	RGB Signal
51	TxIN0	R0	14	TxIN14	G5
52	TxIN1	R1	15	TxIN15	B0
54	TxIN2	R2	19	TxIN18	B1
55	TxIN3	R3	20	TxIN19	B2
56	TxIN4	R4	22	TxIN20	B3
3	TxIN6	R5	23	TxIN21	B4
4	TxIN7	G0	24	TxIN22	B5
6	TxIN8	G1	27	TxIN24	Hsync
7	TxIN9	G2	28	TxIN25	Vsync
11	TxIN12	G3	30	TxIN26	DE
12	TxIN13	G4	31	TxCLKIN	Clock

LVDS INTERFACE

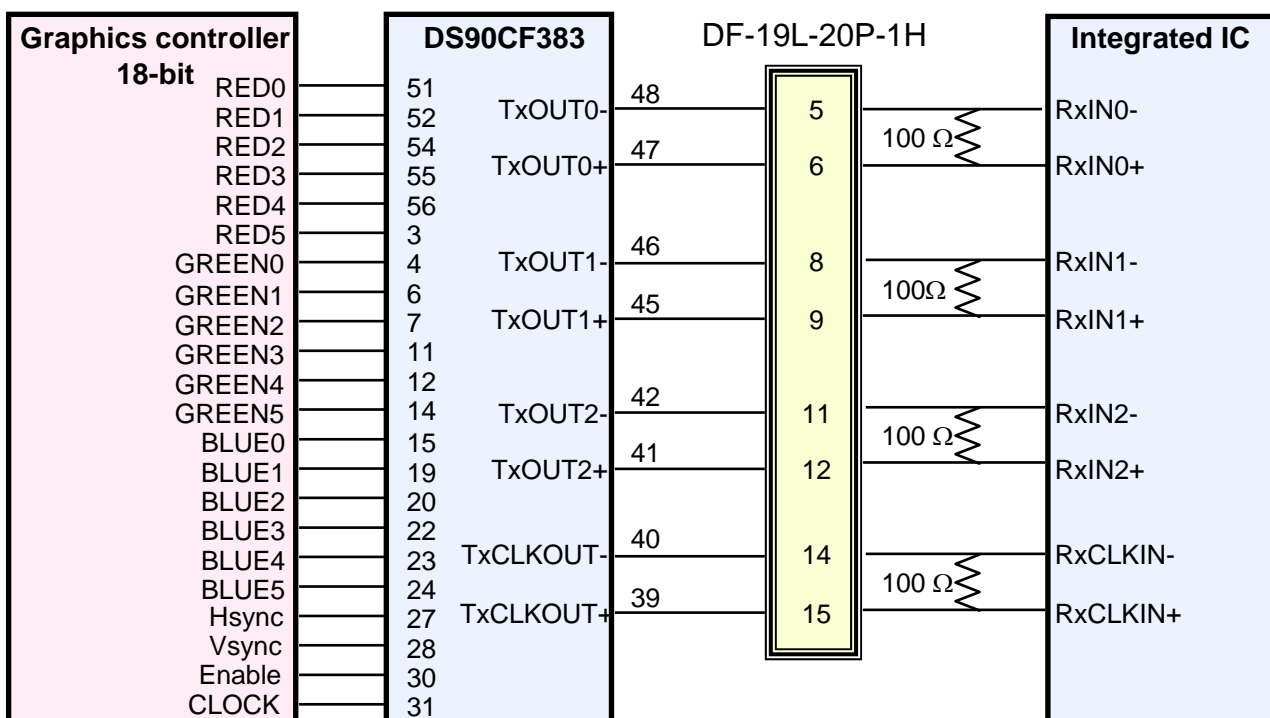

Note : The LCD Module uses a 100ohm resistor between positive and negative lines of each receiver input.

5.3 BACK LIGHT UNIT

Connector : JST, BHSR - 02VS -01

Pin NO.	Symbol	Color	Function
1	HOT	Pink	High Voltage
2	COLD	White	Ground

5.4 Timing Diagrams of LVDS For Transmission

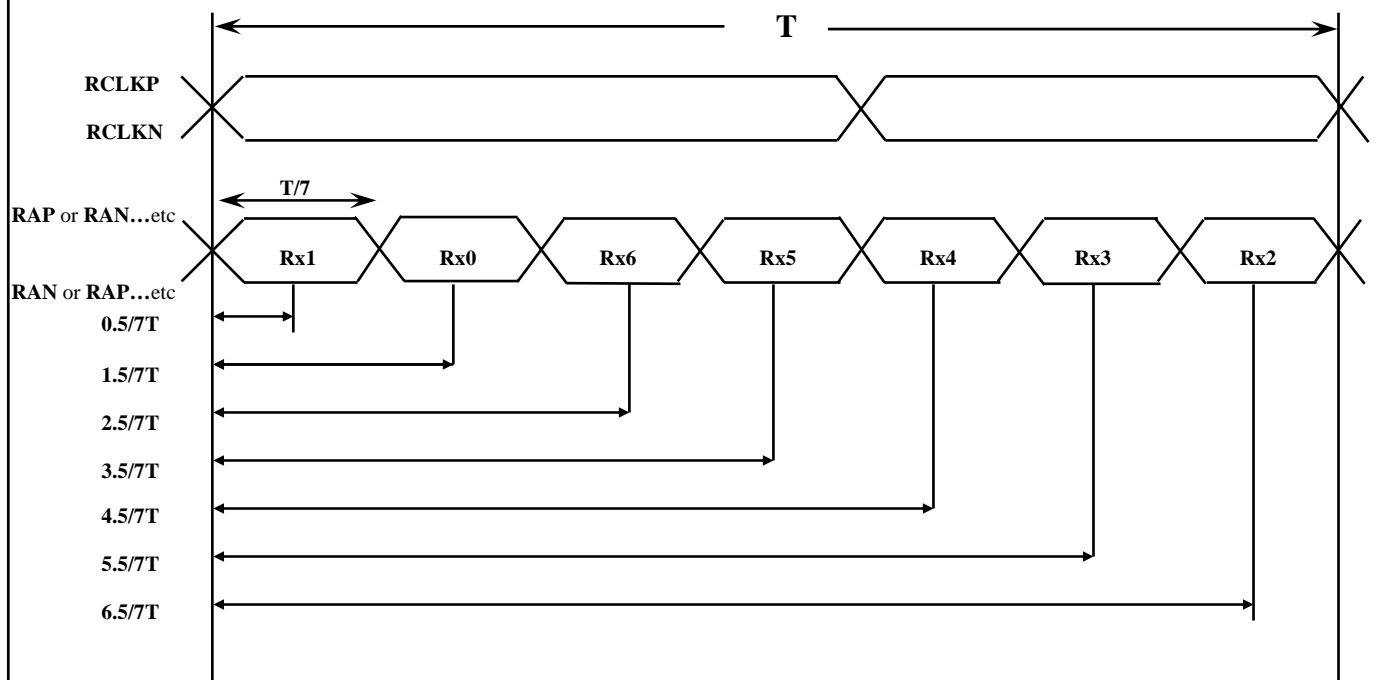

Note: LVDS Input RAP,RAN,RBP,RBN...etc) is 7bit data stream.

5.5 Input Signals, Basic Display Colors and Gray Scale of Each Color

Approval

COLOR	DISPLAY	DATA SIGNAL																GRAY SCALE LEVEL		
		RED					GREEN					BLUE								
		R0	R1	R2	R3	R4	R5	G0	G1	G2	G3	G4	G5	B0	B1	B2	B3		B4	B5
COLOR	BLACK	0	0	0	0	0	0	0	0	0	0	0	0	0	0	0	0	0	0	-
	BLUE	0	0	0	0	0	0	0	0	0	0	0	0	1	1	1	1	1	1	-
	GREEN	0	0	0	0	0	0	1	1	1	1	1	1	0	0	0	0	0	0	-
	CYAN	0	0	0	0	0	0	1	1	1	1	1	1	1	1	1	1	1	1	-
	RED	1	1	1	1	1	1	0	0	0	0	0	0	0	0	0	0	0	0	-
	MAGENTA	1	1	1	1	1	1	0	0	0	0	0	0	1	1	1	1	1	1	-
	YELLOW	1	1	1	1	1	1	1	1	1	1	1	1	0	0	0	0	0	0	-
	WHITE	1	1	1	1	1	1	1	1	1	1	1	1	1	1	1	1	1	1	-
GRAY SCALE OF RED	BLACK	0	0	0	0	0	0	0	0	0	0	0	0	0	0	0	0	0	0	R0
	DARK ↑	1	0	0	0	0	0	0	0	0	0	0	0	0	0	0	0	0	0	R1
		0	1	0	0	0	0	0	0	0	0	0	0	0	0	0	0	0	0	R2
		:	:	:	:	:	:	:	:	:	:	:	:	:	:	:	:	:	:	R3~R60
		:	:	:	:	:	:	:	:	:	:	:	:	:	:	:	:	:	:	
	↓ LIGHT	1	0	1	1	1	1	0	0	0	0	0	0	0	0	0	0	0	0	R61
		0	1	1	1	1	1	0	0	0	0	0	0	0	0	0	0	0	0	R62
	RED	1	1	1	1	1	1	0	0	0	0	0	0	0	0	0	0	0	0	R63
GRAY SCALE OF GREEN	BLACK	0	0	0	0	0	0	0	0	0	0	0	0	0	0	0	0	0	0	G0
	DARK ↑	0	0	0	0	0	0	1	0	0	0	0	0	0	0	0	0	0	0	G1
		0	0	0	0	0	0	0	1	0	0	0	0	0	0	0	0	0	0	G2
		:	:	:	:	:	:	:	:	:	:	:	:	:	:	:	:	:	:	G3~G60
		:	:	:	:	:	:	:	:	:	:	:	:	:	:	:	:	:	:	
	↓ LIGHT	0	0	0	0	0	0	1	0	1	1	1	1	0	0	0	0	0	0	G61
		0	0	0	0	0	0	0	1	1	1	1	1	0	0	0	0	0	0	G62
	GREEN	0	0	0	0	0	0	1	1	1	1	1	1	0	0	0	0	0	0	G63
GRAY SCALE OF BLUE	BLACK	0	0	0	0	0	0	0	0	0	0	0	0	0	0	0	0	0	0	B0
	DARK ↑	0	0	0	0	0	0	0	0	0	0	0	0	1	0	0	0	0	0	B1
		0	0	0	0	0	0	0	0	0	0	0	0	0	1	0	0	0	0	B2
		:	:	:	:	:	:	:	:	:	:	:	:	:	:	:	:	:	:	B3~B60
		:	:	:	:	:	:	:	:	:	:	:	:	:	:	:	:	:	:	
	↓ LIGHT	0	0	0	0	0	0	0	0	0	0	0	0	1	0	1	1	1	1	B61
		0	0	0	0	0	0	0	0	0	0	0	0	0	1	1	1	1	1	B62
	GREEN	0	0	0	0	0	0	0	0	0	0	0	0	1	1	1	1	1	1	B63

Note 1) Definition of gray :
 Rn: Red gray, Gn: Green gray, Bn: Blue gray (n=gray level)
 Note 2) Input signal: 0 =Low level voltage, 1=High level voltage

5.6 Pixel Format in the display

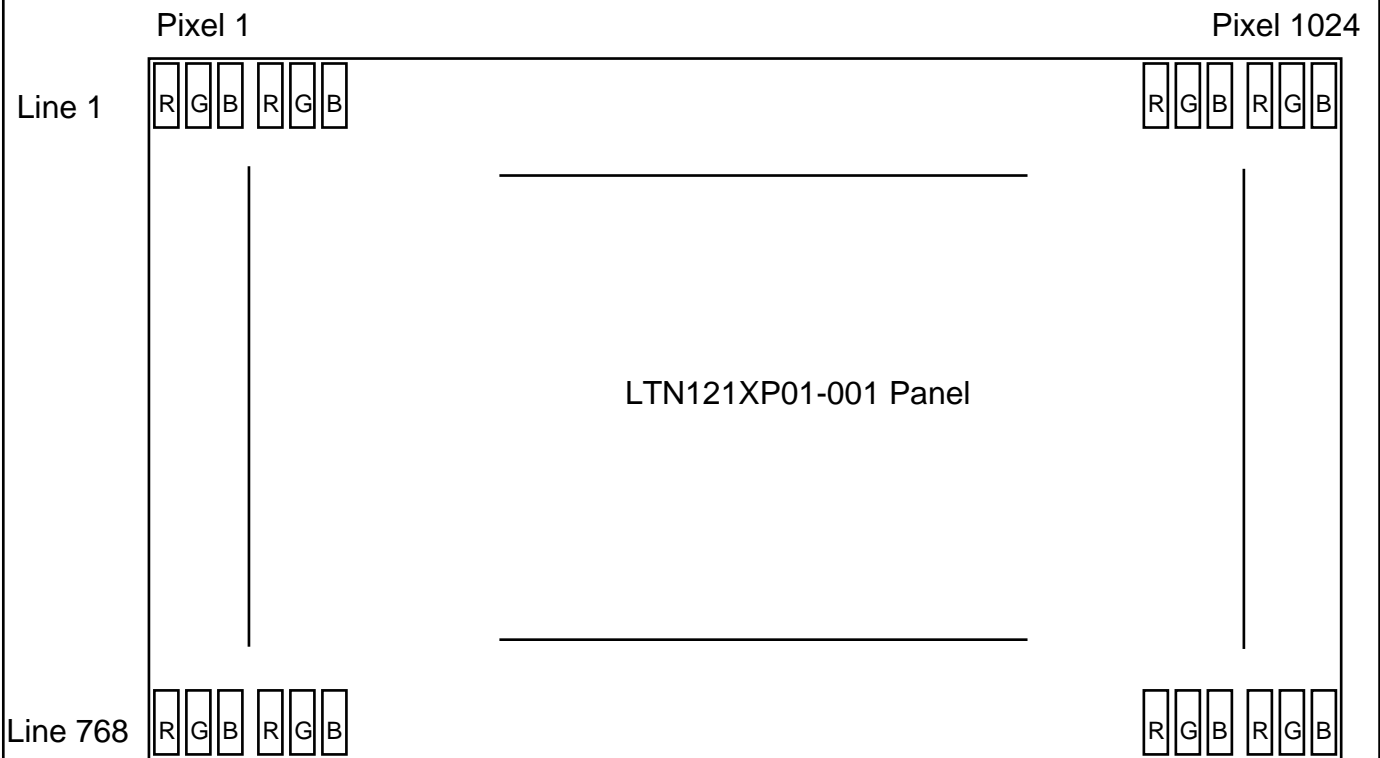

6. INTERFACE TIMING

6.1 Timing Parameters

Signal	Item	Symbol	MIN	TYP	MAX	Unit	Note
Frame Frequency	Cycle	T_v	773	806	1000	lines	
Vertical Active Display Term	Display Period	T_{VD}	-	768	-	lines	
One Line Scanning Time	Cycle	T_H	1060	1344	1750	clocks	
Horizontal Active Display Term	Display Period	T_{HD}	-	1024	-	clocks	

6.2 Timing diagrams of interface signal

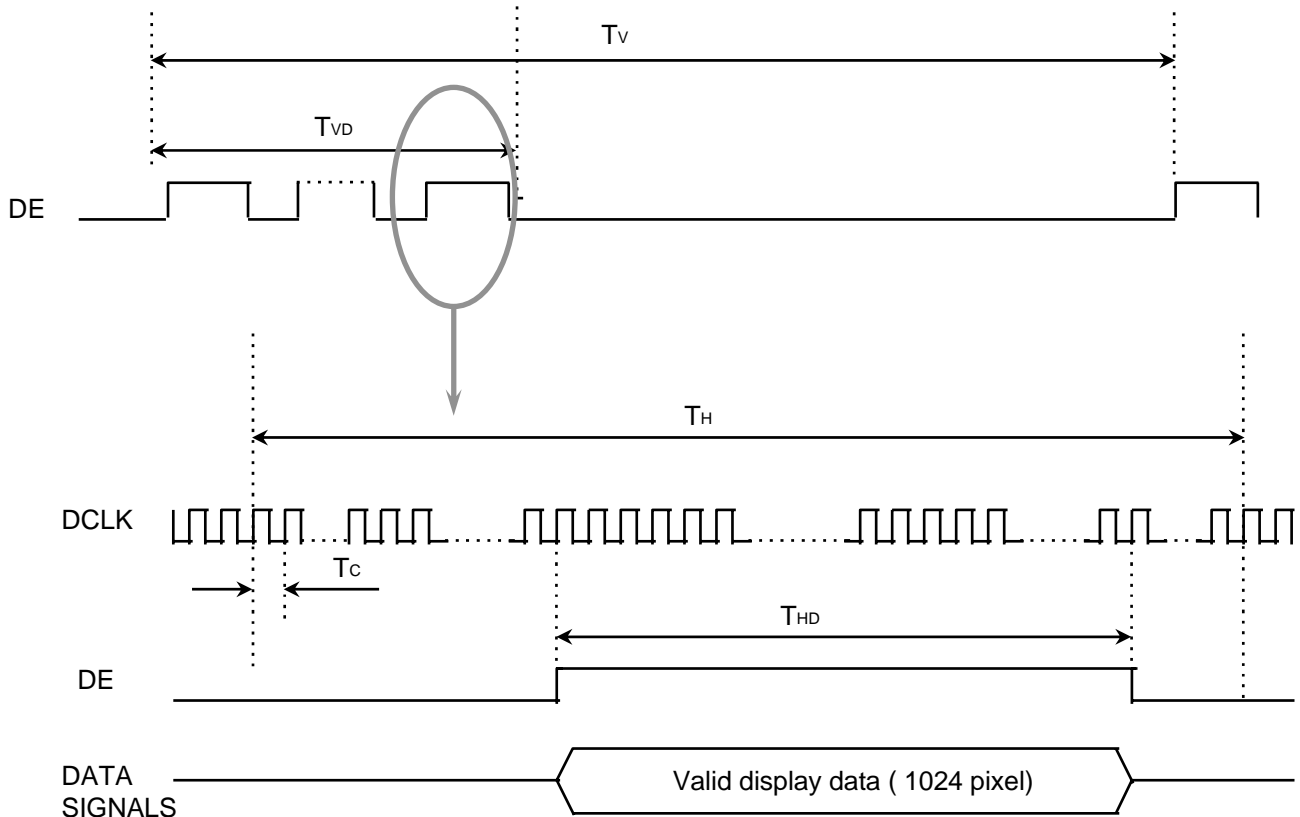

6.3 Power ON/OFF Sequence

: To prevent a latch-up or DC operation of the LCD module, the power on/off sequence shall be as shown below.

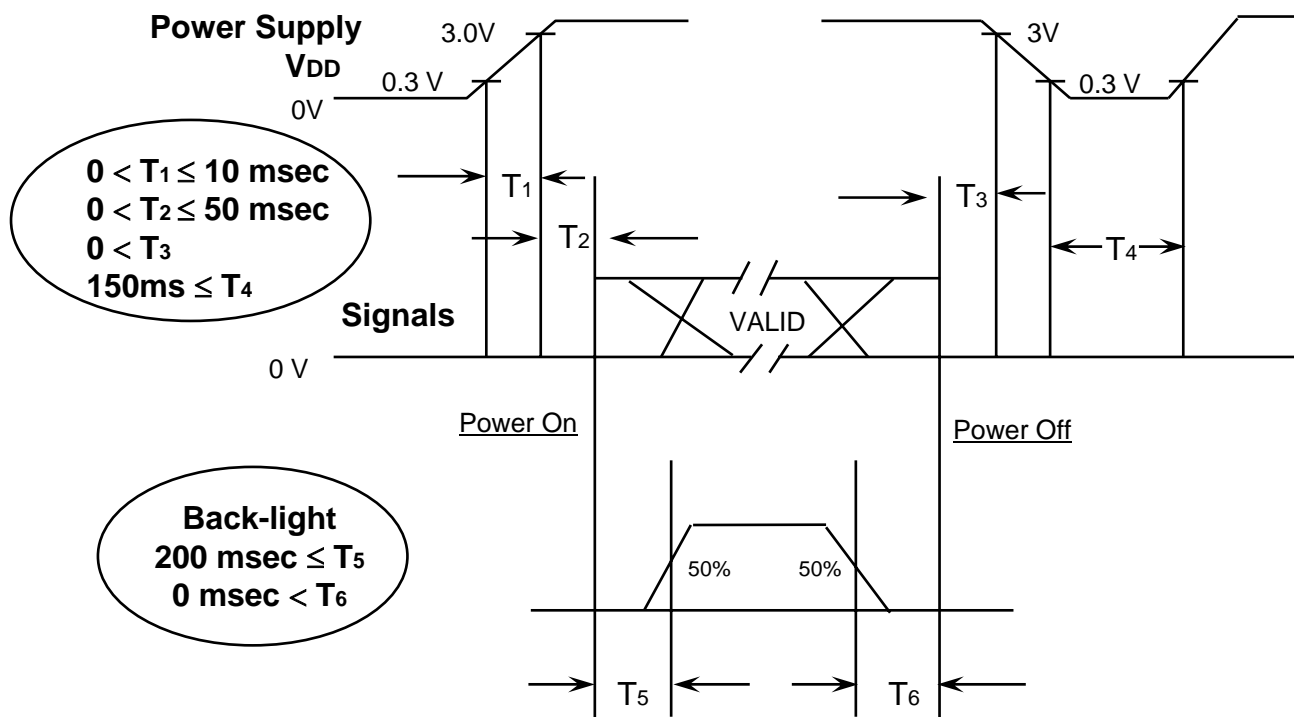

Power ON/OFF Sequence

- T1 : Vdd rising time from 0.3V to 3.0V
- T2 : The time from Vdd to valid data at power ON.
- T3 : The time from valid data off to Vdd off at power Off.
- T4 : Vdd off time for Windows restart
- T5 : The time from valid data to B/L enable at power ON.
- T6 : The time from valid data off to B/L disable at power Off.

NOTE.

- (1) The supply voltage of the external system for the module input should be the same as the definition of VDD.
- (2) Apply the lamp voltage within the LCD operation range. When the backlight turns on before the LCD operation or the LCD turns off before the backlight turns off, the display may momentarily become white.
- (3) In case of VDD = off level, please keep the level of input signals on the low or keep a high impedance.
- (4) T4 should be measured after the module has been fully discharged between power off and on period.
- (5) Interface signal shall not be kept at high impedance when the power is on.

7. Mechanical Outline Dimension

Approval

[Refer to the Next page]

NO	PART NAME	CODE NO	SPECIFICATION	Q'TY	WEIGHT		UNFOLDED DIM. OF MEDIA	REMARK
					FINISH	MATERIAL		

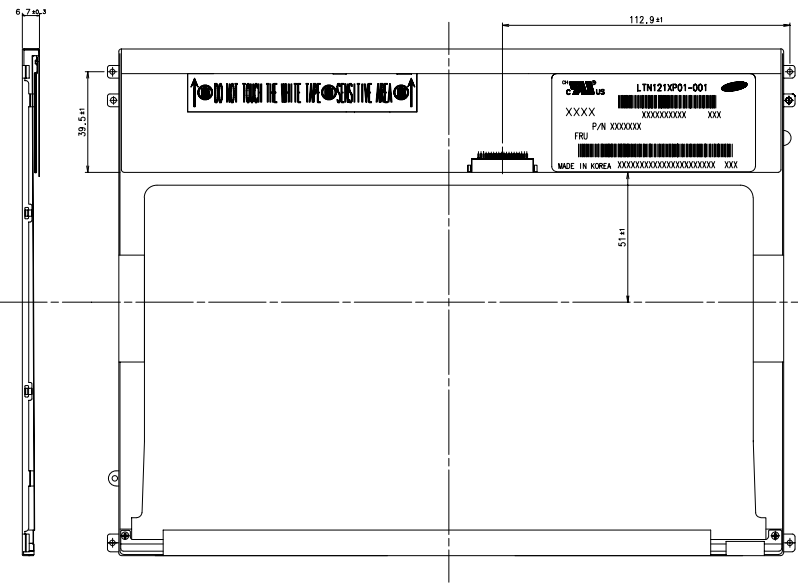
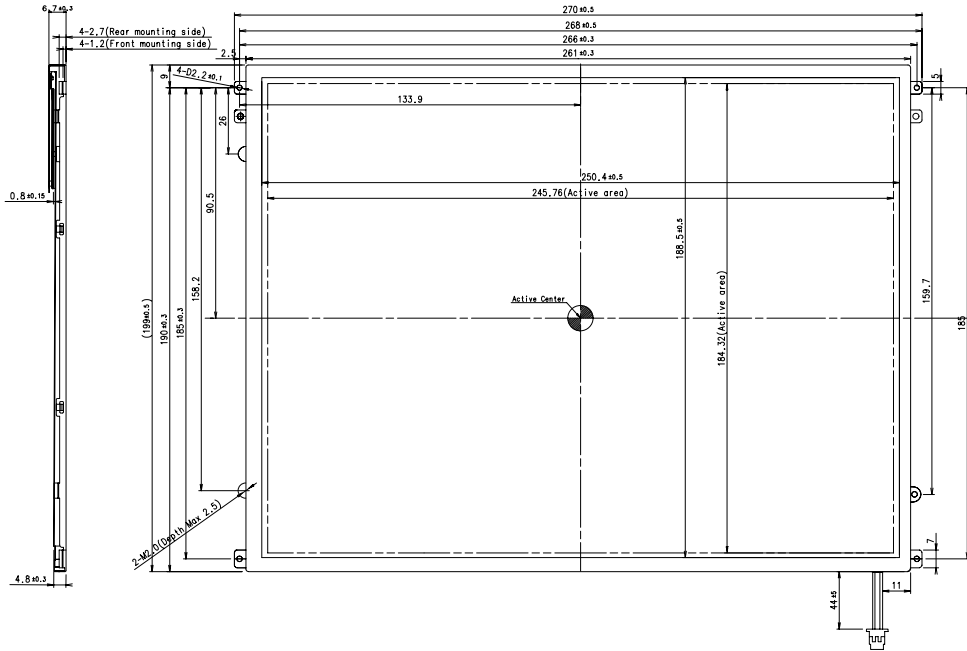

- * NOTE
- INPUT CONN. SPEC.
- PART NO / MAKER : DF19L-20P-1H / HIROSE
 - MATCHING CONN. SPEC.
- PART NO / MAKER : DF19G-20S-1C / HIROSE
 - CCFT LAMP CONN. SPEC.
- MAKER : JST
- PART NO : BHSR-02VS-01
 - MEASURING FORCE : 750±250gf-cm
 - WEIGHT SPEC : 305g TYP, 320g MAX
 - SCREW TORQUE: 2.5kgf(min)/3.0kgf(max)

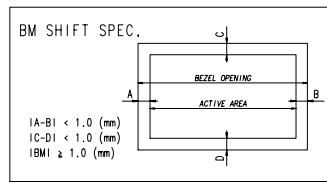

Z0-0-V-TR

REV	DATE	DESCRIPTION OF REVISION					REASON		CHG'D BY
UNIT	mm	DRA'N BY	DES'D BY	CHK'D BY	APP'D BY	MODEL NAME	LTN121XP01-001		
SCALE	1/1	Y.S.MWK	Y.S.MWK	H.S.OHN	D.C.YANG	PART/SHEET NAME	OUTLINE DIMENSION SHEET 1/1		
TOLERANCE	±0.5	07.01.22	07.01.22	07.01.22	07.01.22	SPEC. NO.			
SAMSUNG ELECTRONICS							CODE NO.	VER. 000	

8. PACKING

1. CARTON(Internal Package)

(1) Packing Form

Corrugated Cardboard box and Corrupad form as shock absorber

(2) Packing Method

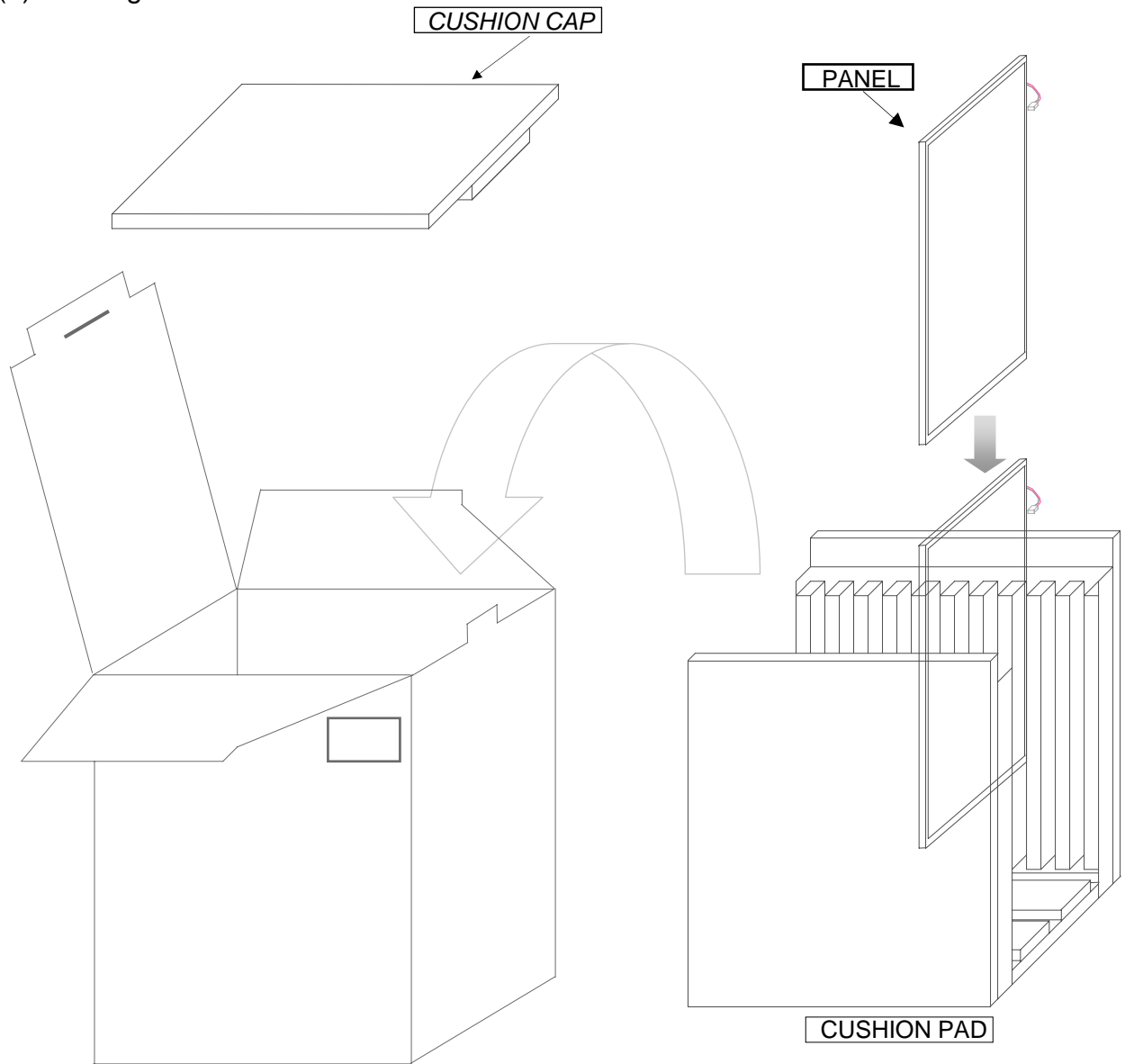

PACKING CASE

- Note 1) Total Weight : Approximately 4.0 kg
2) Acceptance number of piling : 10 sets
3) Carton size : 295(W) × 280(D) × 364(H)
4) MAX accumulation quantity : 5 cartons

Approval

No	Part name	Quantity
1	Static electric protective sack	10
2	Packing case (Inner box) included shock absorber	1 set
3	Pictorial marking	2 pcs
4	Carton	1 set

9. Product Markings and Others

A nameplate bearing followed by is affixed to a shipped product at the specified location on each product.

- (1) Parts number : LTN121XP01-001
- (2) Revision : Three letters
- (3) Control code : One letter
- (4) Lot number : X X X X XXX XX X XXX

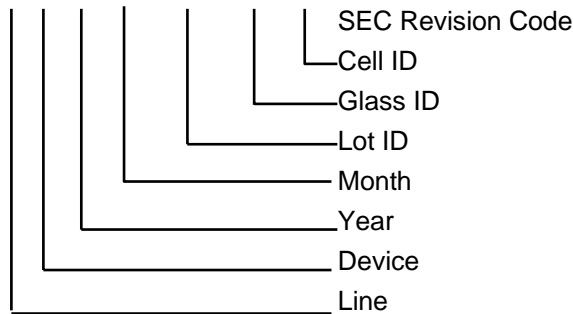

(5) Product Label Definition - HQ



- TFT-LCD Product name : LTN121XP01
- Lot number : 4W7XXXXXXXXX
- Revision Code : 001
- Inspected work week : 0712(2007 Year, the 12th week)
- P/N : Lenovo Part Number (42T0413)
- EC NO : Engineering Change Number (Blank)
- FRU : Field Replaceable Unit Part Number (Blank)
- Header Code : 1ZDCZ
- Lenovo Lot No : 11S42T0413Z1ZDCZ XXXXXX XXX

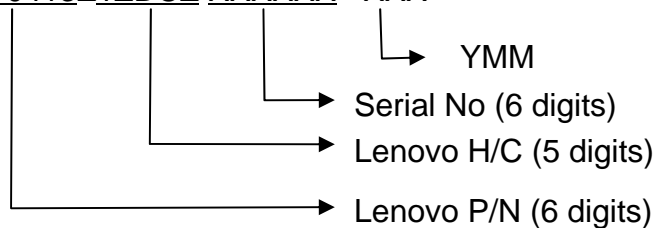

10. GENERAL PRECAUTIONS

1. Handling

- (a) When the module is assembled, It should be attached to the system firmly using selected mounting holes. Be careful not to twist and bend the modules.
- (b) Refrain from strong mechanical shock and / or any force to the module. In addition to damage, this may cause improper operation or damage to the module and CCFT backlight.
- (c) Note that polarizers are very fragile and could be easily damaged. Do not press or scratch the surface harder than a HB pencil lead.
- (d) Wipe off water droplets or oil immediately. If you leave the droplets for a long time, Staining and discoloration may occur.
- (e) If the surface of the polarizer is dirty, clean it using some absorbent cotton or soft cloth.
- (f) The desirable cleaners are water, IPA (Isopropyl Alcohol) or Hexane. Do not use Ketone type materials(ex. Acetone), Ethyl alcohol, Toluene, Ethyl acid or Methyl chloride. It might permanent damage to the polarizer due to chemical reaction.
- (g) If the liquid crystal material leaks from the panel, it should be kept away from the eyes or mouth. In case of contact with hands, legs or clothes, it must be washed away thoroughly with soap.
- (h) Protect the module from static, it may cause damage to the C-MOS Gate Array IC.
- (i) Use fingerstalls with soft gloves in order to keep display clean during the incoming inspection and assembly process.
- (j) Do not disassemble the module.
- (k) Do not pull or fold the lamp wire.
- (l) Do not adjust the variable resistor which is located on the back side.
- (m) Protection film for polarizer on the module shall be slowly peeled off just before use so that the electrostatic charge can be minimized.
- (n) Pins of I/F connector shall not be touched directly with bare hands.

2. STORAGE

- (a) Do not leave the module in high temperature, and high humidity for a long time. It is highly recommended to store the module with temperature from 0 to 35°C and relative humidity of less than 70%.
- (b) Do not store the TFT-LCD module in direct sunlight.
- (c) The module shall be stored in a dark place. It is prohibited to apply sunlight or fluorescent light during the store.

3. OPERATION

- (a) Do not connect, disconnect the module in the “ Power On” condition.
- (b) Power supply should always be turned on/off by following item 6.3 “ Power on/off sequence “.
- (c) Module has high frequency circuits. Sufficient suppression to the electromagnetic interference shall be done by system manufacturers. Grounding and shielding methods may be important to minimize the interference.
- (d) The cable between the backlight connector and its inverter power supply shall be a minimized length and be connected directly . The longer cable between the backlight and the inverter may cause lower luminance of lamp(CCFT) and may require higher startup voltage(Vs).

4. OTHERS

- (a) Ultra-violet ray filter is necessary for outdoor operation.
- (b) Avoid condensation of water. It may result in improper operation or disconnection of electrode.
- (c) Do not exceed the absolute maximum rating value. (the supply voltage variation, input voltage variation, variation in part contents and environmental temperature, so on) Otherwise the module may be damaged.
- (d) If the module displays the same pattern continuously for a long period of time, it can be the situation when the image “sticks” to the screen.
- (e) This module has its circuitry PCB's on the rear side and should be handled carefully in order not to be stressed.

11. EDID

Approval

Address (HEX)	FUNCTION	Value	BIN	DEC	ASCII or Data	Notes
		HEX				
00		00	00000000	0		
01	Header	FF	11111111	255		EDID Header
02		FF	11111111	255		
03		FF	11111111	255		
04		FF	11111111	255		
05		FF	11111111	255		
06		FF	11111111	255		
07		00	00000000	0		
08	ID Manufacturer Name	30	00110000	48	L E N	3 character ID
09		AE	10101110	174		"IBM" as an end-customer
0A	ID Product Code	02	00000010	2		XGA PVA
0B		40	01000000	64		
0C	32-bit serial no.	00	00000000	0		
0D		00	00000000	0		
0E		00	00000000	0		
0F		00	00000000	0		
10	Week of manufacture	00	00000000	0		
11	Year of manufacture	11	00010001	17	2007	2005
12	EDID Structure Ver.	01	00000001	1	1	EDID Ver. 1.0
13	EDID revision #	03	00000011	3	3	EDID Rev. 3
14	Video input definition	80	10000000	128		
15	Max H image size	19	00011001	25	25	25 cm (approx)
16	Max V image size	12	00010010	18	18	18 cm (approx)
17	Display Gamma	78	01111000	120	2.2	Gamma 2.2
18	Feature support	EA	11101010	234		
19	Red/green low bits	87	10000111	135		10000111
1A	Blue/white low bits	F5	11110101	245		11111110
1B	Red x/ high bits	94	10010100	148	0.580	Red x0.580= 1001010010
1C	Red y	57	01010111	87	0.340	Red y0.340= 0101011100
1D	Green x	4F	01001111	79	0.310	Green x0.310= 0100111101
1E	Green y	8C	10001100	140	0.550	Green y0.550= 1000110011
1F	Blue x	27	00100111	39	0.155	Blue x0.155= 0010011111
20	Blue y	27	00100111	39	0.155	Blue y0.155= 0010011111
21	White x	50	01010000	80	0.313	White x0.313= 0101000001
22	White y	54	01010100	84	0.329	White y0.329= 0101010001
23	Established timing 1	21	00100001	33		
24	Established timing 2	08	00001000	8		
25	Established timing 3	00	00000000	0		
26	Standard timing #1	01	00000001	1		not used
27		01	00000001	1		
28	Standard timing #2	01	00000001	1		not used
29		01	00000001	1		
2A	Standard timing #3	01	00000001	1		not used
2B		01	00000001	1		
2C	Standard timing #4	01	00000001	1		not used
2D		01	00000001	1		
2E	Standard timing #5	01	00000001	1		not used
2F		01	00000001	1		
30	Standard timing #6	01	00000001	1		not used
31		01	00000001	1		
32	Standard timing #7	01	00000001	1		not used
33		01	00000001	1		
34	Standard timing #8	01	00000001	1		not used
35		01	00000001	1		

36	Detailed timing/monitor descriptor #1	64	01100100	100	65.00	Main clock= 65MHz (@60Hz)	
37		19	00011001	25			
38		00	00000000	0	1024		Hor active=1024 pixels
39		40	01000000	64	320		Hor blanking=320 pixels
3A		41	01000001	65			4bit : 4bit
3B		00	00000000	0	768		Vertical active=768 lines
3C		26	00100110	38	38		Vertical blanking=38 lines
3D		30	00110000	48			4bit : 4bit
3E		18	00011000	24	24		Hor sync. Offset=24 pixels
3F		88	10001000	136	136		H sync. Width=136 pixels
40		36	00110110	54	3 6		V sync. Offset=3 lines V sync. Width=6 lines
41		00	00000000	0			2bit : 2bit :2bit :2bit
42		F5	11110101	245	245		H image size= 245 mm(approx)
43		B8	10111000	184	184		V image size = 184 mm(approx)
44		00	00000000	0			
45		00	00000000	0			No Horizontal Border
46		00	00000000	0			No Vertical Border
47	18	00011000	24				
48	Detailed timing/monitor descriptor #2	00	00000000	0	0.00	Main clock= 43.33 MHz (@50Hz)	
49		00	00000000	0			
4A		00	00000000	0	0		Hor active=1024 pixels
4B		10	00010000	16	16		Hor blanking=320 pixels
4C		00	00000000	0	0		4bit : 4bit
4D		00	00000000	0	0		Vertical active=768 lines
4E		00	00000000	0	0		Vertical blanking=38 lines
4F		00	00000000	0			4bit : 4bit
50		00	00000000	0	0		Hor sync. Offset=24 pixels
51		00	00000000	0	0		H sync. Width=136 pixels
52		00	00000000	0	0 0		V sync. Offset=3 lines V sync. Width=6 lines
53		00	00000000	0			2bit : 2bit :2bit :2bit
54		00	00000000	0	0		H image size= 246 mm(approx)
55		00	00000000	0	0		V image size = 185 mm(approx)
56		00	00000000	0			
57		00	00000000	0			No Horizontal Border
58		00	00000000	0			No Vertical Border
59	00	00011000	0				
5A	descriptor #3	00	00000000	0		Manufacturer Specified (Timing)	
5B		00	00000000	0			
5C		00	00000000	0			
5D		0F	00001111	15			
5E		00	00000000	0			
5F		61	01100001	97	1024		(Horizontal active pixel /8)-31
60		43	01000011	67			Image Aspect Ratio(4:3)
61		3C	00111100	60			Low Refresh Rate #1(60Hz)
62		00	00000000	0			Not supported
63		00	00000000	0			Not supported
64		00	00000000	0			Not supported
65		13	00010011	19	195		Brightness(1/10nit)
66		02	00000010	2			Feature flag(PVA mode)
67		00	00000000	0			
68		4C	01001100	76	S E C		supplier ID "SEC"
69		A3	10100011	163			
6A		58	01011000	88	[X]		Product code "XP"
6B	50	01010000	80	[P]	(Hex, LSB first)		

6C	Detailed timing/monitor descriptor #4	00	00000000	0		Monitor Name Tag (ASCII)
6D		00	00000000	0		
6E		00	00000000	0		
6F		FE	11111110	254		
70		00	00000000	0		
71		4C	01001100	76	[L]	
72		54	01010100	84	[T]	
73		4E	01001110	78	[N]	
74		31	00110001	49	[1]	
75		32	00110010	50	[2]	
76		31	00110001	49	[1]	
77		58	01011000	88	[X]	
78		50	01010000	80	[P]	
79		30	00110000	48	[0]	
7A		31	00110001	49	[1]	
7B	30	00110000	48	[0]		
7C	30	00110000	48	[0]		
7D	31	00110001	49	[1]		
7E	Extension Flag	00	00000000	0		
7F	Checksum	A3	10100011	163		