

SAMSUNG

ELECTRONICS

Preliminary



TO : General

DATE : Feb, 13, 2009

SAMSUNG TFT-LCD

MODEL NO. : LTN140AT02-C

NOTE :

- Extension code [**C02**]
- Surface type [**Glare**]

Any Modification of Specification is not allowed without SEC's Permission.

SAMSUNG ELECTRONICS CO., LTD.



Samsung Secret

Doc.No.	LTN140AT02-C	Rev.No	04-P01-S-090213	Page	1 / 27
----------------	--------------	---------------	-----------------	-------------	--------

CONTENTS

Revision History	----- (3)
General Description	----- (4)
1. Absolute Maximum Ratings	----- (5)
1.1 Absolute Ratings of environment	
1.2 Electrical Absolute Ratings	
2. Optical Characteristics	----- (7)
3. Electrical Characteristics	----- (10)
3.1 TFT LCD Module	
3.2 LED Driver	
4. Block Diagram	----- (13)
4.1 TFT LCD Module	
4.2 LED connection and placement	
5. Input Terminal Pin Assignment	----- (14)
5.1 Input Signal & Power	
5.2 LVDS Interface	
5.3 Timing Diagrams of LVDS For Transmitting	
5.4 Input Signals, Basic Display Colors and Gray Scale of Each Color.	
5.5 Pixel format	
6. Interface Timing	----- (19)
6.1 Timing Parameters	
6.2 Timing Diagrams of interface Signal	
6.3 Power ON/OFF Sequence	
7. Outline Dimension	----- (21)
8. Packing	----- (22)
9. Markings & Others	----- (23)
10. General Precautions	----- (25)

Samsung Secret

REVISION HISTORY

Preliminary

Date	Rev. No.	Page	Summary
Nov. 25. 2008	P00	All	. The preliminary specification was first issued.
Dec. 19. 2008	P01	22	. Packing SPEC was changed.

Samsung Secret

GENERAL DESCRIPTION

DESCRIPTION

LTN140AT02-G is a color active matrix TFT (Thin Film Transistor) liquid crystal display (LCD) that uses amorphous silicon TFT as a switching devices. This model is composed of a TFT LCD panel, a driver circuit and a backlight unit. The resolution of a 14.0" contains 1,366 x 768 pixels and can display up to 262,144 colors. 6 O'clock direction is the Optimum viewing angle.

FEATURES

- High contrast ratio, high aperture structure
- 1366 x 768 pixels resolution
- Low power consumption
- Fast Response
- LED BLU with LED driver
- 60% Color Gamut
- DE(Data enable) only mode
- 3.3V LVDS Interface
- Onboard EEDID chip
- Pb-free product

APPLICATIONS

- Notebook PC
- If the usage of this product is not for PC application, but for others, please contact SEC.

GENERAL INFORMATION

Item	Specification	Unit	Note
Display area	309.4(H) x 173.95(V) (14.0" diagonal)	mm	
Driver element	a-Si TFT active matrix		
Display colors	262,144		
Number of pixel	1366 x RGB(3) x 768	pixel	16 : 9
Pixel arrangement	RGB vertical stripe		
Pixel pitch	0.2265(H) x 0.22265(V) (TYP.)	mm	
Display Mode	Normally white		
Surface treatment	Haze 0, Hard-Coating 3H		

Samsung Secret

Doc.No.	LTN140AT02-C	Rev.No	04-P01-S-090213	Page	4 / 27
----------------	--------------	---------------	-----------------	-------------	--------

Mechanical Information

Item		Min.	Typ.	Max.	Unit	Note
Module size	Horizontal (H)	323.0	323.5	324	mm	
	Vertical (V)	191.5	192.0	192.5	mm	
	Depth (D)	-	-	5.2	mm	
Weight		-		350	g	

1. ABSOLUTE MAXIMUM RATINGS

1.1 ENVIRONMENTAL ABSOLUTE RATINGS

Item	Symbol	Min.	Max.	Unit	Note
Storage temperate	TSTG	-20	60	°C	(1)
Operating temperate (Temperature of glass surface)	TOPR	0	50	°C	(1)
Shock (non-operating)	Snop	-	240	G	(2),(4)
Vibration (non-operating)	Vnop	-	2.41	G	(3),(4)

Note (1) Temperature and relative humidity range are shown in the figure below.
 95 % RH Max. (40 °C ≥ Ta)
 Maximum wet - bulb temperature at 39 °C or less. (Ta > 40 °C) No condensation

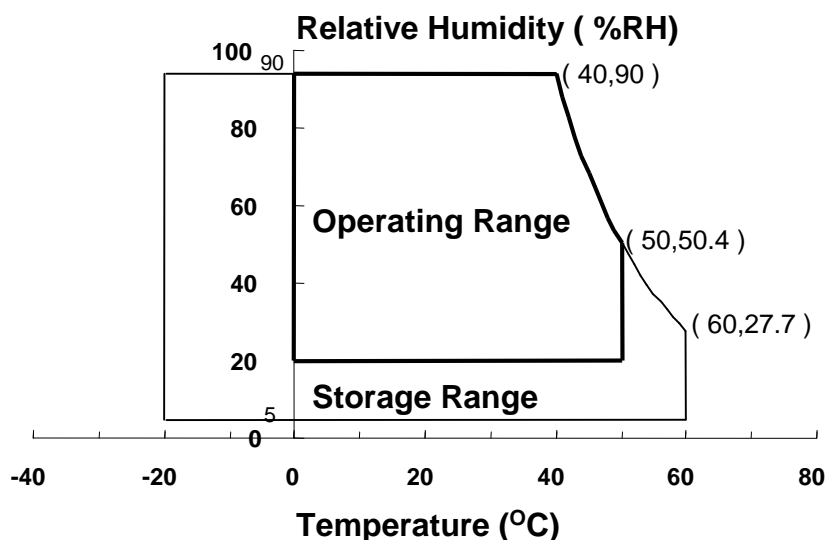

- (2) 2ms, half sine wave, one time for ±X, ±Y, ±Z.
- (3) 5 - 500 Hz, random vibration, 30min for X, Y, Z.
- (4) At testing Vibration and Shock, the fixture in holding the Module to be tested have to be hard and rigid enough so that the Module would not be twisted or bent by the fixture.

Samsung Secret

1.2 ELECTRICAL ABSOLUTE RATINGS

(1) TFT LCD MODULE

$V_{DD} = 3.3V, V_{SS} = GND = 0V$

Item	Symbol	Min.	Max.	Unit	Note
Power Supply Voltage	V_{DD}	$V_{SS} - 0.3$	3.6	V	(1)

Note (1) Within T_a ($25 \pm 2 \text{ }^\circ\text{C}$)

(2) BACK-LIGHT UNIT

$T_a = 25 \pm 2 \text{ }^\circ\text{C}$

Item	Symbol	Min.	Typ.	Max.	Unit	Note
LED Current	I_L	-	20	-	mArms	(1)
LED Voltage	V_L	-	3.2	-	V	(1)

Note 1) Permanent damage to the device may occur if maximum values are exceeded

Functional operation should be restricted to the conditions described under normal operating conditions.

Samsung Secret

2. OPTICAL CHARACTERISTICS

The following items are measured under stable conditions. The optical characteristics should be measured in a dark room or equivalent state with the methods shown in Note (5).
 Measuring equipment : TOPCON BM-5A and PR-650

* Ta = 25 ± 2 °C, V_{DD}=3.3V, f_v= 60Hz, f_{DCLK} = 72.33MHz, I_L = 20 mArms

Item	Symbol	Condition	Min.	Typ.	Max	Unit	Note
Contrast Ratio (5 Points)	CR		500	-	-	-	(1), (2), (5)
Response Time at Ta (Rising + Falling)	T _{RT_BW}		-	16	20	msec	(1), (3)
Average Luminance of White (5 Points)	Y _{L,AVE}		200	220	-	cd/m ²	I _L =20mA (1), (4)
Color Chromaticity (CIE)	Red	R _X	(0.580)	(0.610)	(0.640)	-	(1), (5) PR-650
		R _Y	(0.310)	(0.340)	(0.370)		
	Green	G _X	(0.315)	(0.345)	(0.375)		
		G _Y	(0.560)	(0.590)	(0.620)		
	Blue	B _X	(0.125)	(0.155)	(0.185)		
		B _Y	(0.030)	(0.060)	(0.090)		
	White	W _X	(0.283)	(0.313)	(0.343)		
		W _Y	(0.299)	(0.329)	(0.359)		
Color Gamut			-	60	-	%	
Viewing Angle	Hor.	θ _L	40	-	-	Degrees	(1), (5) BM-5A
		θ _R	40	-	-		
	Ver.	φ _H	15	-	-		
		φ _L	30	-	-		
	Hor.	θ _L	20	-	-	Degrees	
		θ _R	20	-	-		
	Ver.	φ _H	5	-	-		
		φ _L	10	-	-		
13 Points White Variation	δ _L		-	-	1.7	-	(6)

Samsung Secret

Note 1) Definition of Viewing Angle : Viewing angle range($10 \leq C/R$, $100 \leq C/R$)

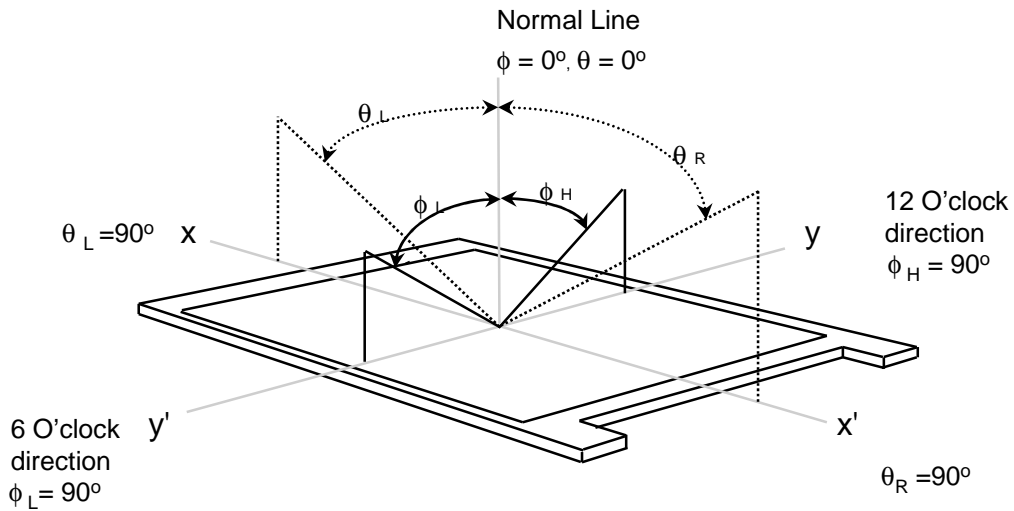

Note 2) Definition of Contrast Ratio (CR) : Ratio of gray max (Gmax) ,gray min (Gmin) at 5 points(4, 5, 7, 9, 10)

$$CR = \frac{CR(4) + CR(5) + CR(7) + CR(9) + CR(10)}{5}$$

Points : (4) , (5) , (7) , (9) , (10) at the figure of Note (6).

Note 3) Definition of Response time :

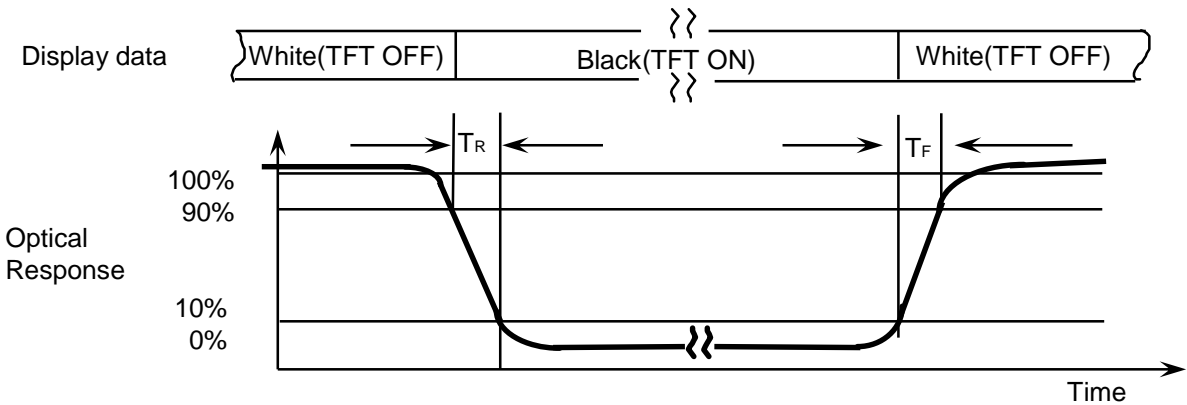

Note 4) Definition of Average Luminance of White : measure the luminance of white at 5 points.

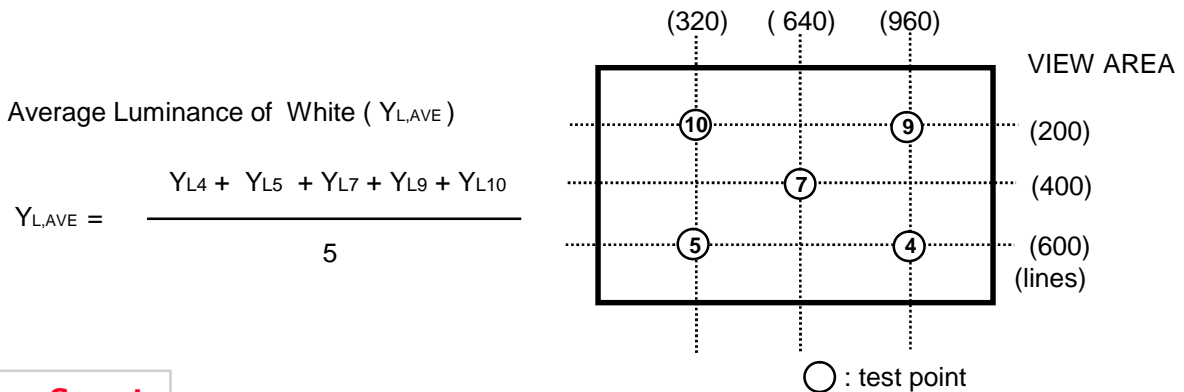

Samsung Secret

Note 5) After stabilizing and leaving the panel alone at a given temperature for 30 min , the measurement should be executed. Measurement should be executed in a stable, windless, and dark room. 30 min after lighting the backlight. This should be measured in the center of screen.
 Environment condition : $T_a = 25 \pm 2 \text{ }^\circ\text{C}$

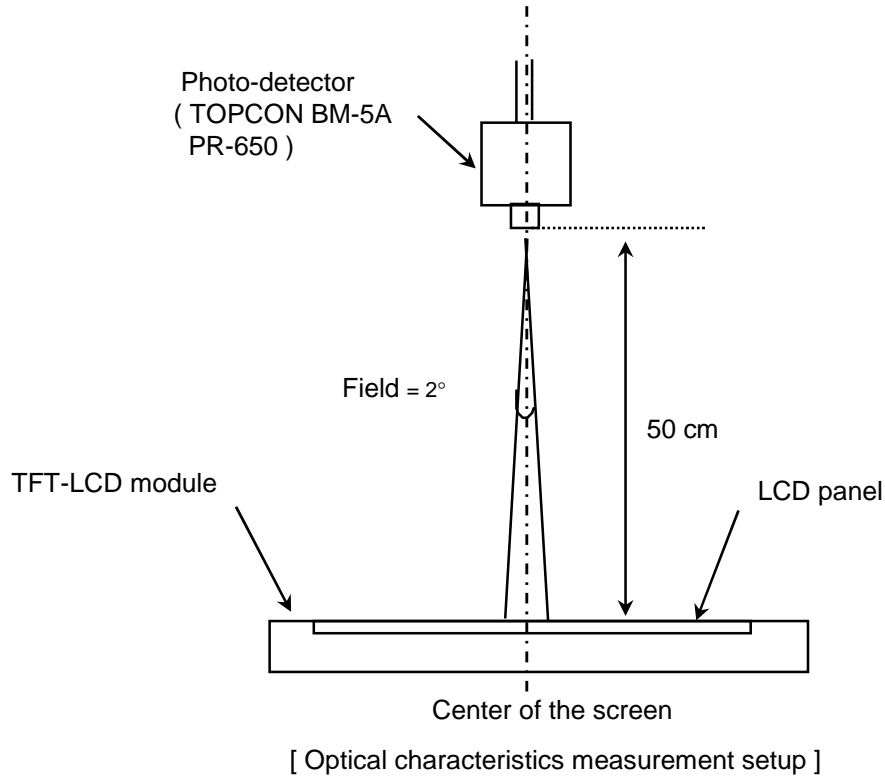

Note 6) Definition of 13 points white variation (δL), CR variation(C_{VER}) [① ~ ⑬]

$$\delta L = \frac{\text{Maximum luminance of 13 points}}{\text{Minimum luminance of 13 points}}$$

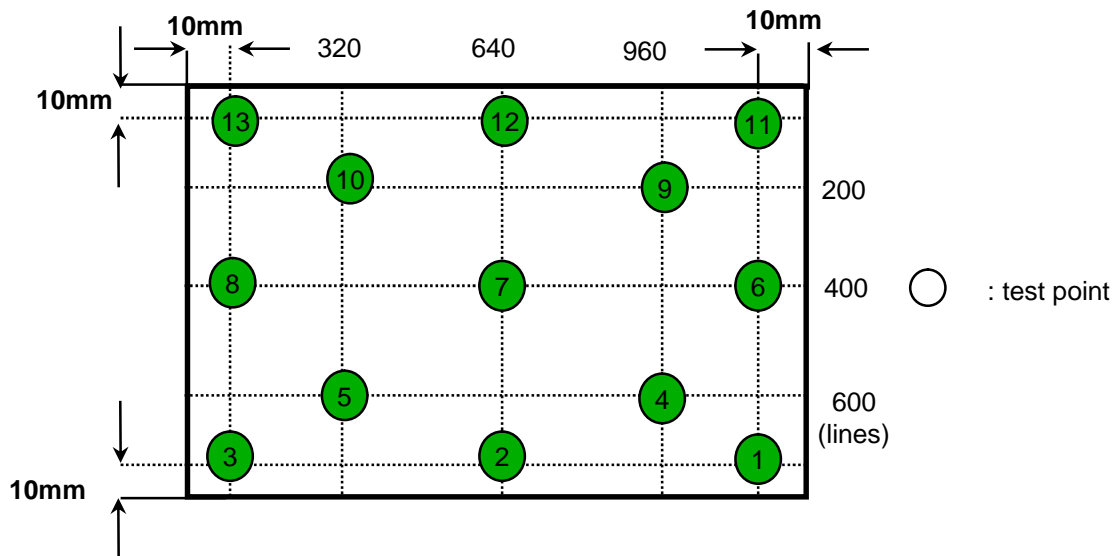

Samsung Secret

3. ELECTRICAL CHARACTERISTICS

Preliminary

3.1 TFT LCD MODULE

Ta= 25 ± 2°C

Item	Symbol	Min.	Typ.	Max.	Unit	Note	
Voltage of Power Supply	V _{DD}	3.0	3.3	3.6	V		
Differential Input Voltage for LVDS Receiver Threshold	High	V _{IH}	-	-	+100	mV	V _{CM} = +1.2V
	Low	V _{IL}	-100	-	-	mV	
Vsync Frequency	f _v	-	60	-	Hz		
Hsync Frequency	f _h	-	47.4	-	KHz	f _v *790	
Main Frequency	f _{DCLK}	-	72.33	-	MHz	f _h *1526	
Rush Current	I _{RUSH}	-	-	1.5	A	(4)	
Current of Power Supply	White	I _{DD}	-	(300)	-	mA	(2),(3)*a
	Mosaic		-	(350)	-	mA	(2),(3)*b
	V. stripe		-	(395)	(485)	mA	(2),(3)*c

Note (1) Display data pins and timing signal pins should be connected.(GND = 0V)

(2) f_v = 60Hz, f_{DCLK} = 72.33MHz, V_{DD} = 3.3V , DC Current.

(3) Power dissipation pattern

*a) White Pattern

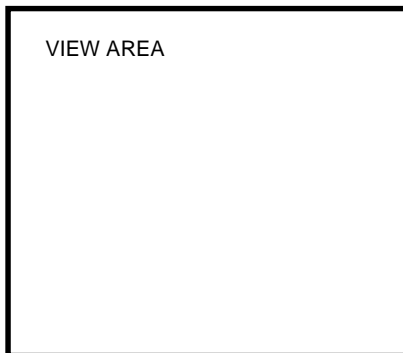

*b) Mosaic Pattern

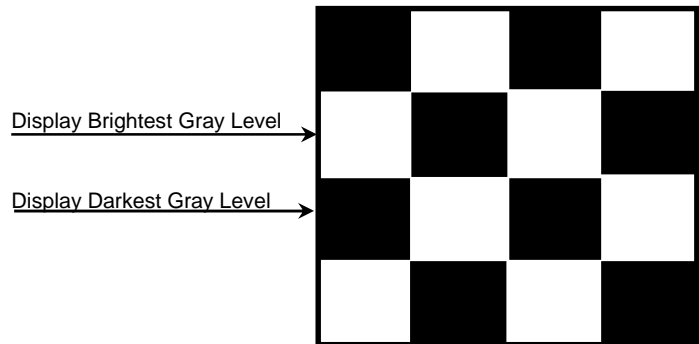

Samsung Secret

*c) 1dot Vertical stripe pattern

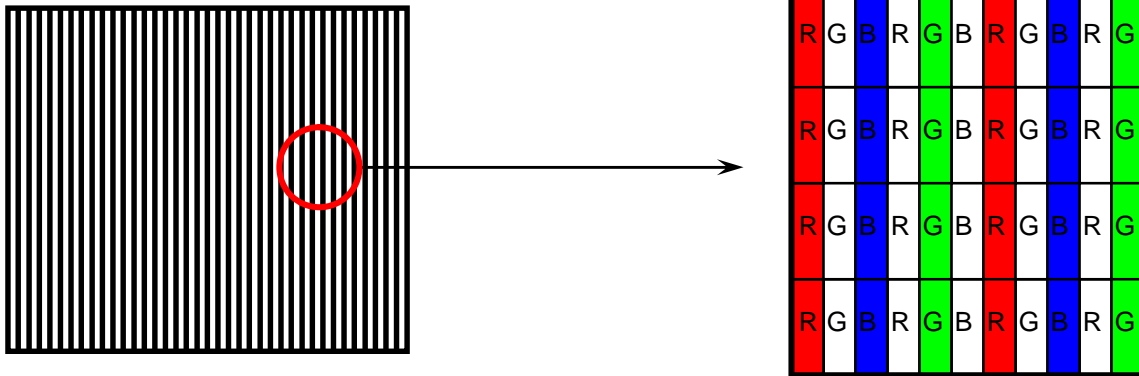

4) Rush current measurement condition

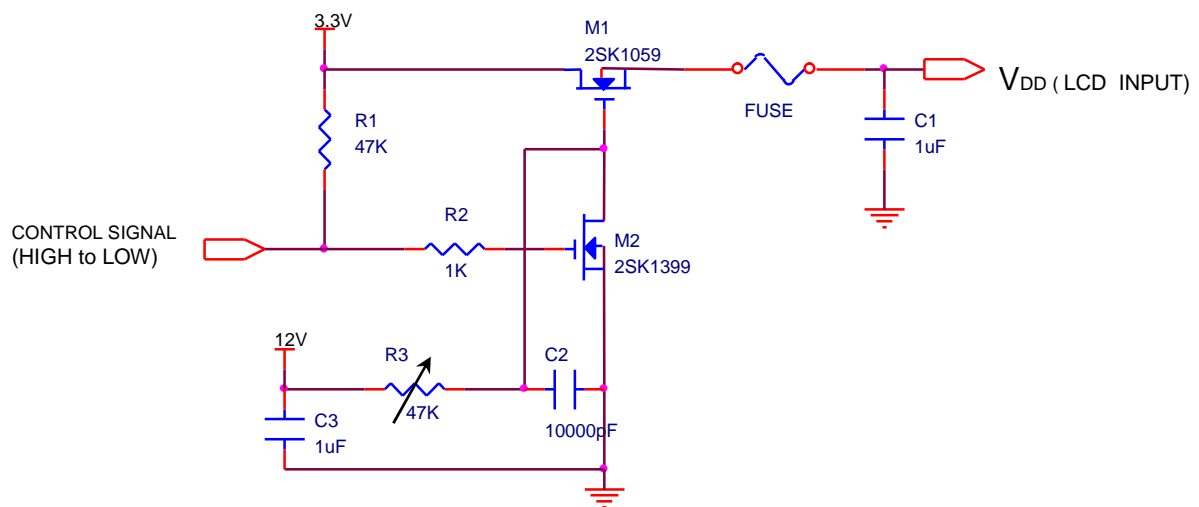

V_{DD} rising time is 470us

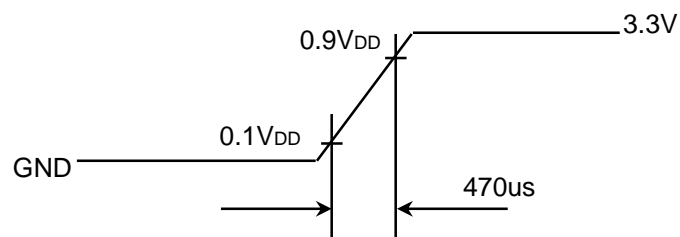

Samsung Secret

3.2 BACK-LIGHT UNIT

Ta= 25 ± 2 °C

Item	Symbol	Min.	Typ.	Max.	Unit	Note
LED Forward Current	IF	-	20	-	mA	
LED Forward Voltage	VF	3.0	3.2	3.4	V	
LED Array Voltage	VP	21.0	22.4	23.8	V	VF X 7 LEDs
Power Consumption	P	-	3.09	3.28	W	IF X VF X 42LEDs
Operating Life Time	Hr	12,000	-	-	Hour	(1)

Note (1) Life time (Hr) of LEDs can be defined as the time in which it continues to operate under the condition Ta= 25 ± 2 °C and IF = 19.0 mArms until one of the following event occurs.

1. When the brightness becomes 50% or lower than the original.

3.3 LED Driver

- On board LED Driver (Manufacturer : Richtek)

Ta= 25 ± 2 °C

Item	Symbol	Min.	Typ.	Max.	Unit	Note
Input Voltage	V _{in}	7	12	21	V	
Operating Frequency	F _o	675	750	825	KHz	
Burst Ratio	D	5	-	100	%	
External PWM Dimming Control Frequency (BLIM)	F _{BLIM}	0.1	-	10	kHz	V _{in} =6~20V, BLIM=PWM 0V~3.3V
Efficiency	η	-	80	-	%	BLIM=100%

Note - Test Equipment : Fluke 45

Samsung Secret

4. BLOCK DIAGRAM

4.1 TFT LCD Module

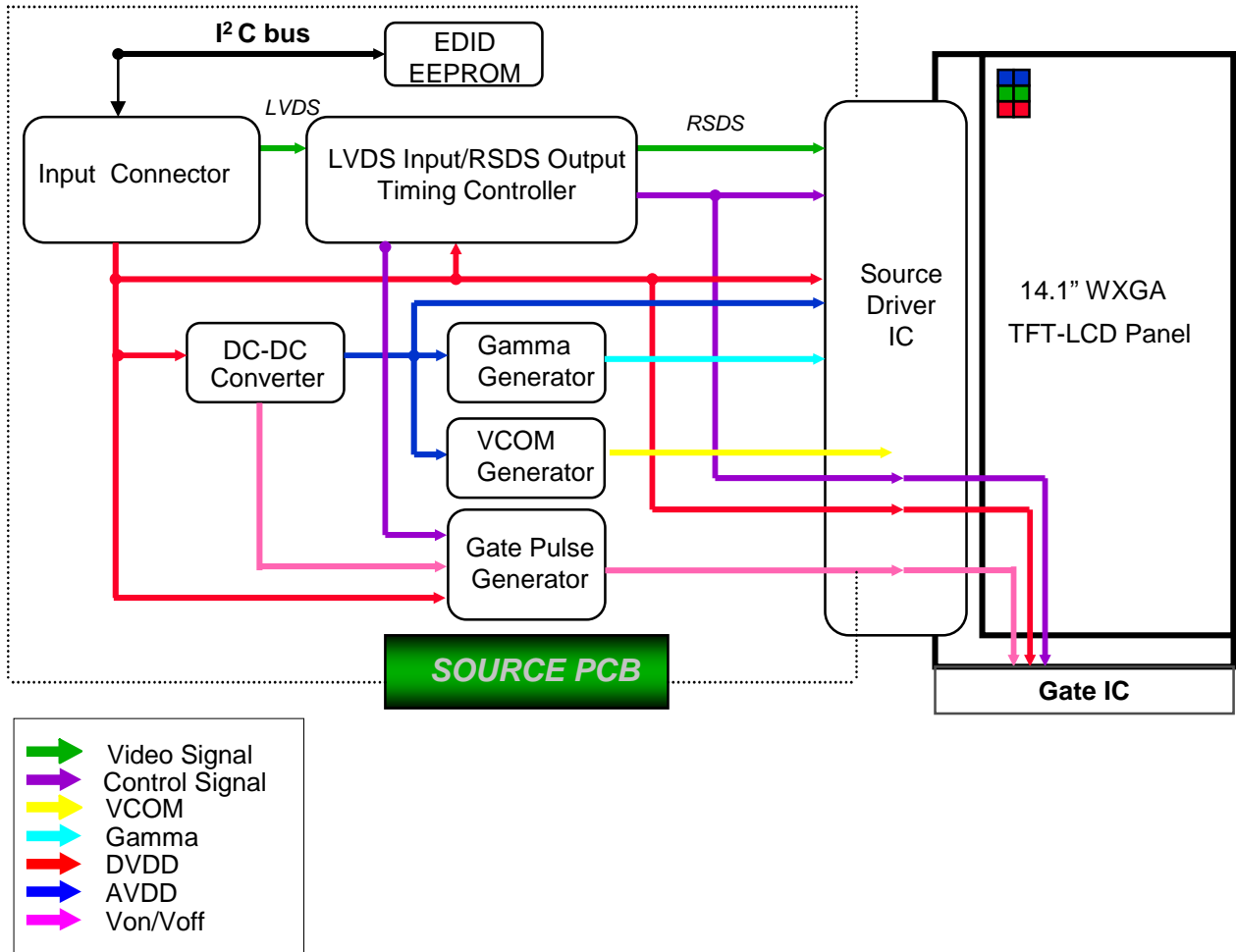

4.2 LED connection and placement

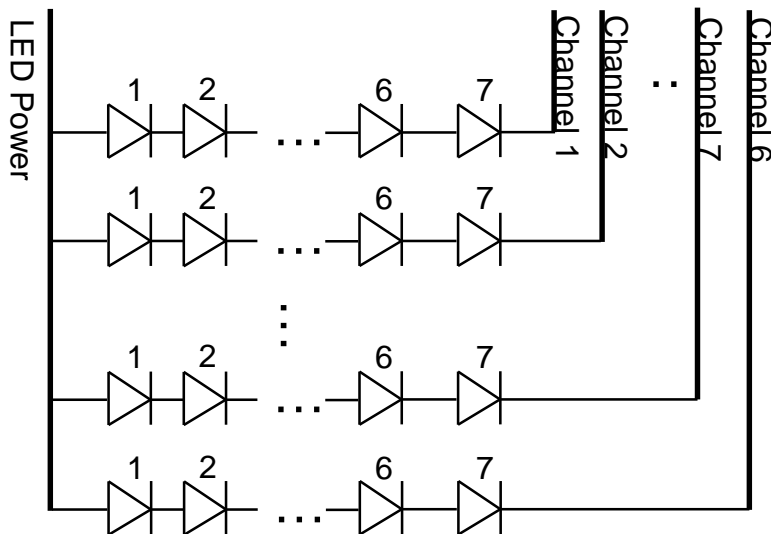

Samsung Secret

5. INPUT TERMINAL PIN ASSIGNMENT

5.1. Input Signal & Power

(LVDS, Connector : I-PEX, 20455-40E or equivalent – Locking type connector)

Pin	Symbol	Function
1	NC	No Connection (Reserved for supplier)
2	VCC	Power Supply, 3.3V (typical)
3	VCC	Power Supply, 3.3V (typical)
4	VCC_EDID	DDC 3.3V power
5	NC	No Connection (Reserved for supplier)
6	CLK_EDID	DDC Clock
7	DATA_EDID	DDC Data
8	RXin0-	- LVDS differential data (R0-R5, G0)
9	RXin0+	+ LVDS differential data (R0-R5, G0)
10	GND	Ground
11	RXin1-	- LVDS differential data (G1-G5, B0-B1)
12	RXn1+	+ LVDS differential data (G1-G5, B0-B1)
13	GND	Ground
14	RXin2-	- LVDS differential data (B2-B5,HS,VS, DE)
15	RXn2+	+ LVDS differential data (B2-B5,HS,VS, DE)
16	GND	Ground
17	CIkIN-	- LVDS differential clock input
18	CIkIN+	+ LVDS differential clock input
19	GND	Ground
20~21	NC	No Connection
22	NC	Ground
23~24	NC	No Connection
25	NC	Ground
26~27	NC	No Connection
28	NC	Ground
29~30	NC	No Connection
31~33	VBL-	LED Ground
34	NC	No Connection
35	PWM	PWM for luminance control
36	LED_EN	BL On/Off (On: 2.0~3.3V, Off: 0~0.5V)
37	NC	No Connection
38~40	VBL(7~20)	*LED Power Supply 7V-20V

Samsung Secret

5.3 LVDS Interface : Transmitter DS90CF363 or Compatible

Pin No.	Name	RGB Signal	Pin No.	Name	RGB Signal
51	TxIN0	R0	14	TxIN14	G5
52	TxIN1	R1	15	TxIN15	B0
54	TxIN2	R2	19	TxIN18	B1
55	TxIN3	R3	20	TxIN19	B2
56	TxIN4	R4	22	TxIN20	B3
3	TxIN6	R5	23	TxIN21	B4
4	TxIN7	G0	24	TxIN22	B5
6	TxIN8	G1	27	TxIN24	Hsync
7	TxIN9	G2	28	TxIN25	Vsync
11	TxIN12	G3	30	TxIN26	DE
12	TxIN13	G4	31	TxCLKIN	Clock

LVDS Interface

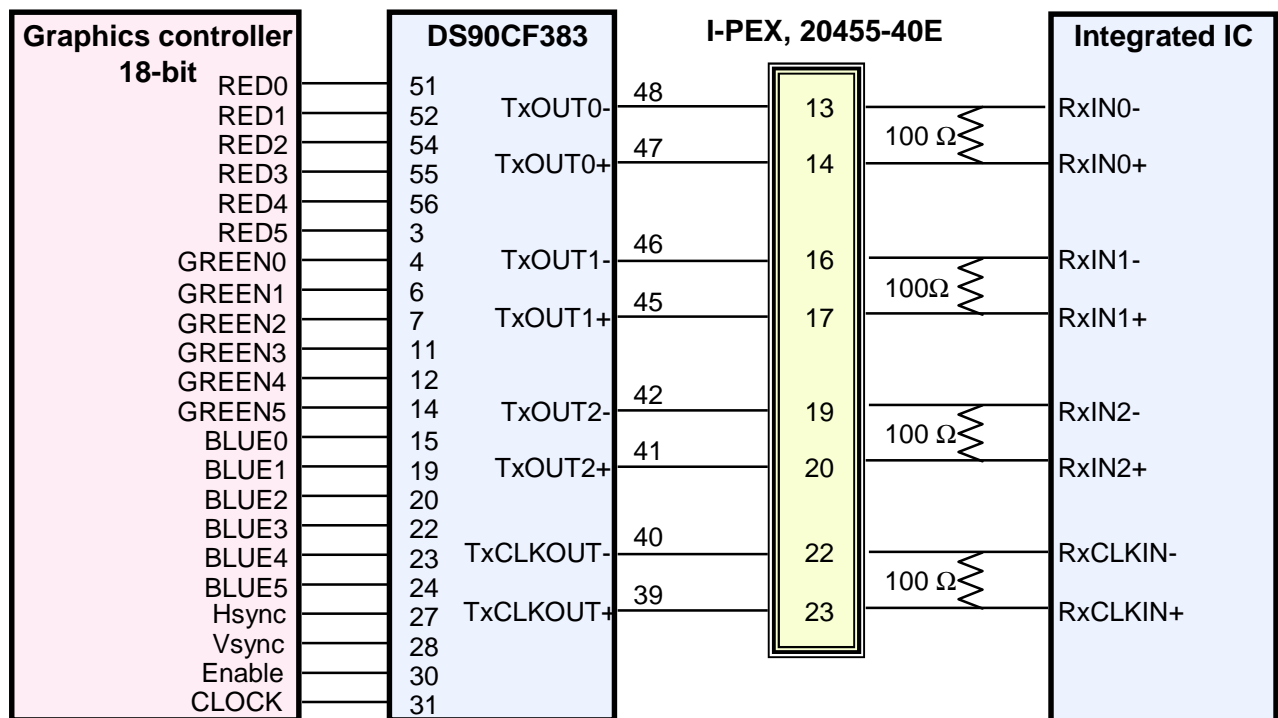

Note : The LCD Module uses a 100ohm resistor between positive and negative lines of each receiver input.

Samsung Secret

5.4 Timing Diagrams of LVDS For Transmission

LVDS Receiver : Integrated T-CON

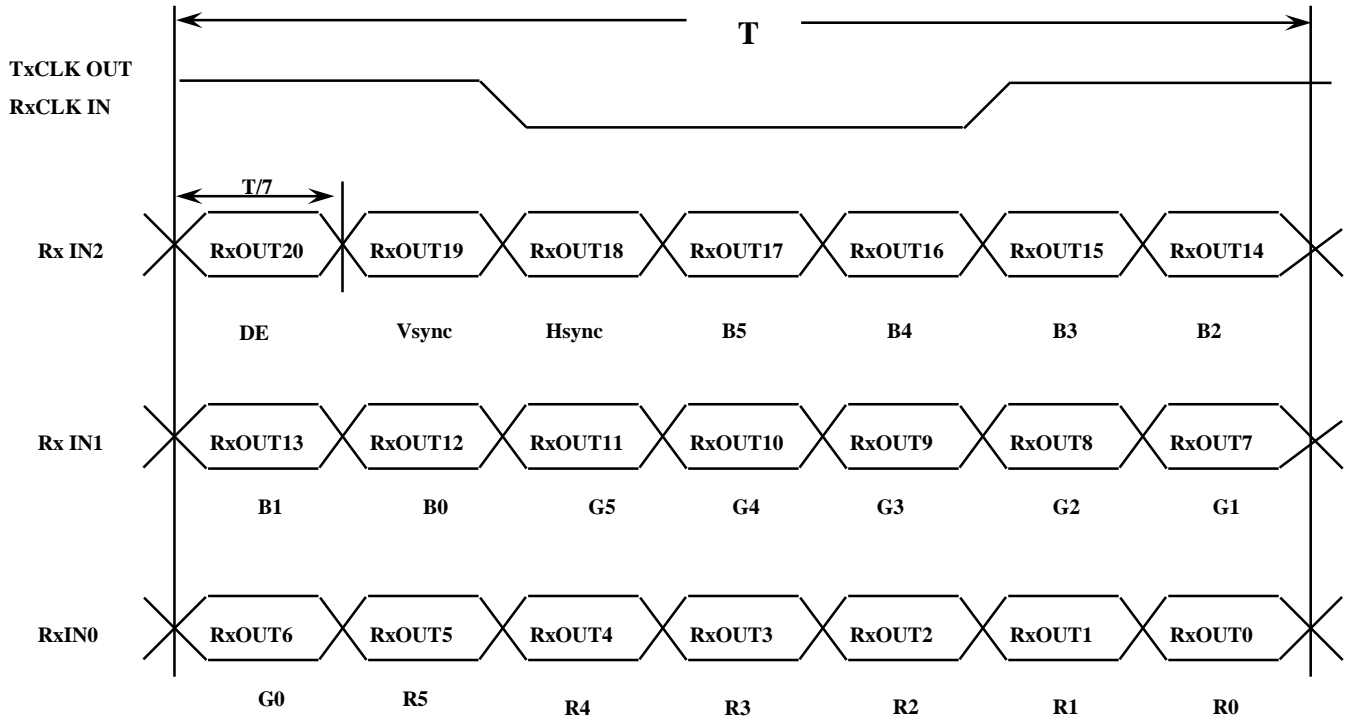

Samsung Secret

5.5 Input Signals, Basic Display Colors and Gray Scale of Each Color

Color	Display	Data Signal																Gray Scale Level	
		Red					Green					Blue							
		R0	R1	R2	R3	R4	R5	G0	G1	G2	G3	G4	G5	B0	B1	B2	B3		45
Basic Colors	Black	0	0	0	0	0	0	0	0	0	0	0	0	0	0	0	0	0	-
	Blue	0	0	0	0	0	0	0	0	0	0	0	0	1	1	1	1	1	-
	Green	0	0	0	0	0	0	1	1	1	1	1	1	0	0	0	0	0	-
	Cyan	0	0	0	0	0	0	1	1	1	1	1	1	1	1	1	1	1	-
	Red	1	1	1	1	1	1	0	0	0	0	0	0	0	0	0	0	0	-
	Magenta	1	1	1	1	1	1	0	0	0	0	0	0	1	1	1	1	1	-
	Yellow	1	1	1	1	1	1	1	1	1	1	1	1	0	0	0	0	0	-
	White	1	1	1	1	1	1	1	1	1	1	1	1	1	1	1	1	1	-
Gray Scale Of Red	Black	0	0	0	0	0	0	0	0	0	0	0	0	0	0	0	0	0	R0
	Dark	1	0	0	0	0	0	0	0	0	0	0	0	0	0	0	0	0	R1
	↑	0	1	0	0	0	0	0	0	0	0	0	0	0	0	0	0	0	R3~R60
	:	:	:	:	:	:	:	:	:	:	:	:	:	:	:	:	:	:	
	:	:	:	:	:	:	:	:	:	:	:	:	:	:	:	:	:	:	
	↓	1	0	1	1	1	1	0	0	0	0	0	0	0	0	0	0	0	R61
	Light	0	1	1	1	1	1	0	0	0	0	0	0	0	0	0	0	0	R62
	Red	1	1	1	1	1	1	0	0	0	0	0	0	0	0	0	0	0	R63
Gray Scale Of Green	Black	0	0	0	0	0	0	0	0	0	0	0	0	0	0	0	0	0	G0
	Dark	0	0	0	0	0	0	1	0	0	0	0	0	0	0	0	0	0	G1
	↑	0	0	0	0	0	0	0	1	0	0	0	0	0	0	0	0	0	G3~G60
	:	:	:	:	:	:	:	:	:	:	:	:	:	:	:	:	:	:	
	:	:	:	:	:	:	:	:	:	:	:	:	:	:	:	:	:	:	
	↓	0	0	0	0	0	0	1	0	1	1	1	1	0	0	0	0	0	G61
	Light	0	0	0	0	0	0	0	1	1	1	1	1	0	0	0	0	0	G62
	Green	0	0	0	0	0	0	1	1	1	1	1	1	0	0	0	0	0	G63
Gray Scale Of Blue	Black	0	0	0	0	0	0	0	0	0	0	0	0	0	0	0	0	0	B0
	Dark	0	0	0	0	0	0	0	0	0	0	0	0	1	0	0	0	0	B1
	↑	0	0	0	0	0	0	0	0	0	0	0	0	0	1	0	0	0	B3~B60
	:	:	:	:	:	:	:	:	:	:	:	:	:	:	:	:	:	:	
	:	:	:	:	:	:	:	:	:	:	:	:	:	:	:	:	:	:	
	↓	0	0	0	0	0	0	0	0	0	0	0	0	1	0	1	1	1	B61
	Light	0	0	0	0	0	0	0	0	0	0	0	0	0	1	1	1	1	B62
	Blue	0	0	0	0	0	0	0	0	0	0	0	0	1	1	1	1	1	B63

Note 1) Definition of gray :

Rn: Red gray, Gn: Green gray, Bn: Blue gray (n=gray level)

Note 2) Input signal: 0 =Low level voltage, 1=High level voltage

Samsung Secret

5.6 Pixel Format in the display

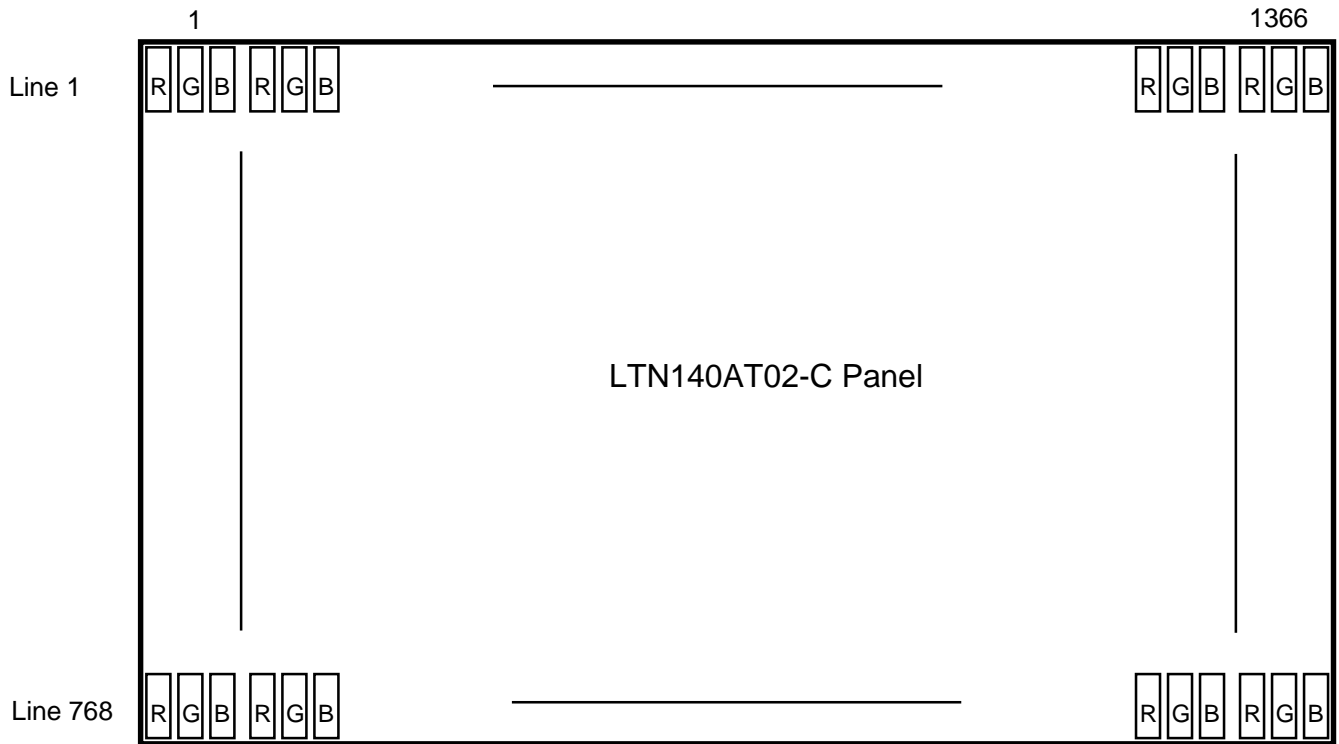

Samsung Secret

6. INTERFACE TIMING

6.1 Timing Parameters

Signal	Item	Symbol	Min.	Typ.	Max.	Unit	Note
Frame Frequency	Cycle	T_V	772	790	974	Lines	
Vertical Active Display Term	Display Period	T_{VD}	-	768	-	Lines	
One Line Scanning Time	Cycle	T_H	1436	1526	1550	Clocks	
Horizontal Active Display Term	Display Period	T_{HD}	-	1366	-	Clocks	

6.2 Timing diagrams of interface signal

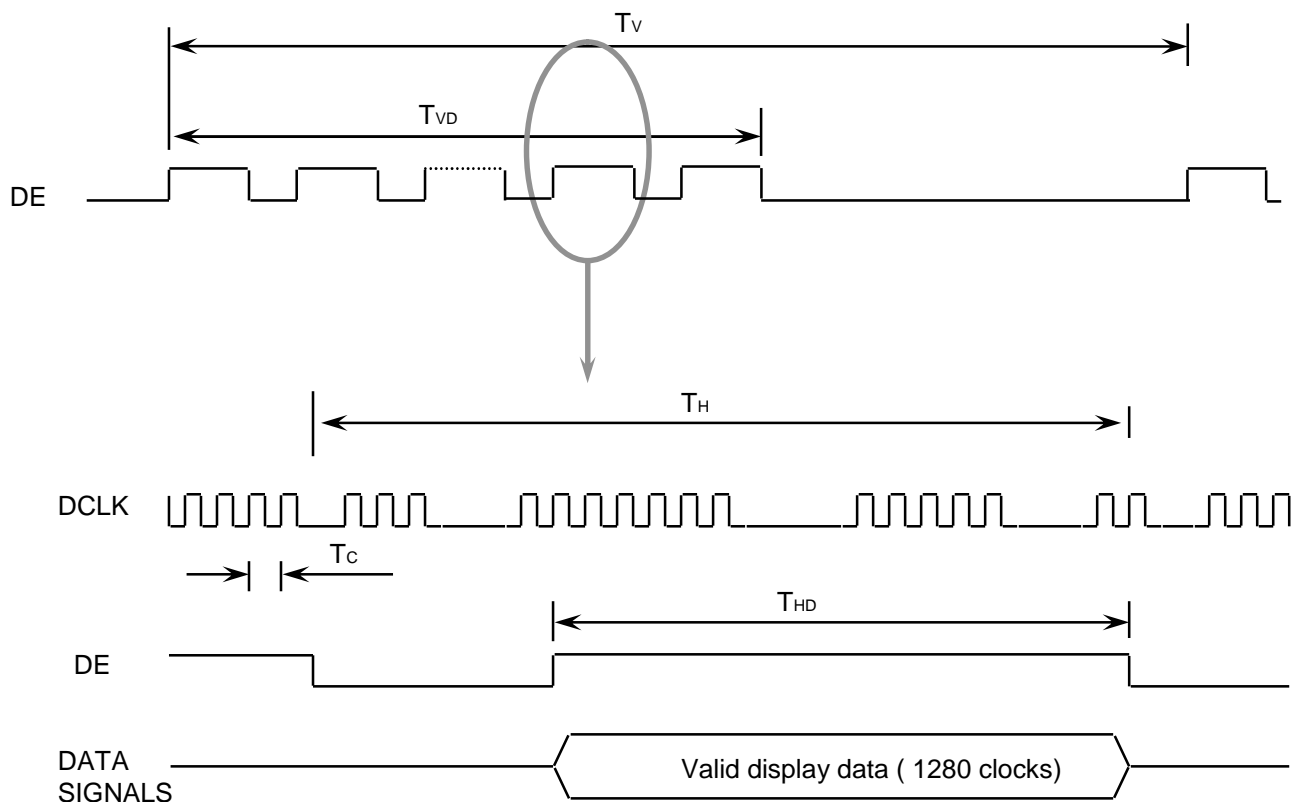

Samsung Secret

6.3 Power ON/OFF Sequence

Preliminary

: To prevent a latch-up or DC operation of the LCD module, the power on/off sequence should be as the diagram below.

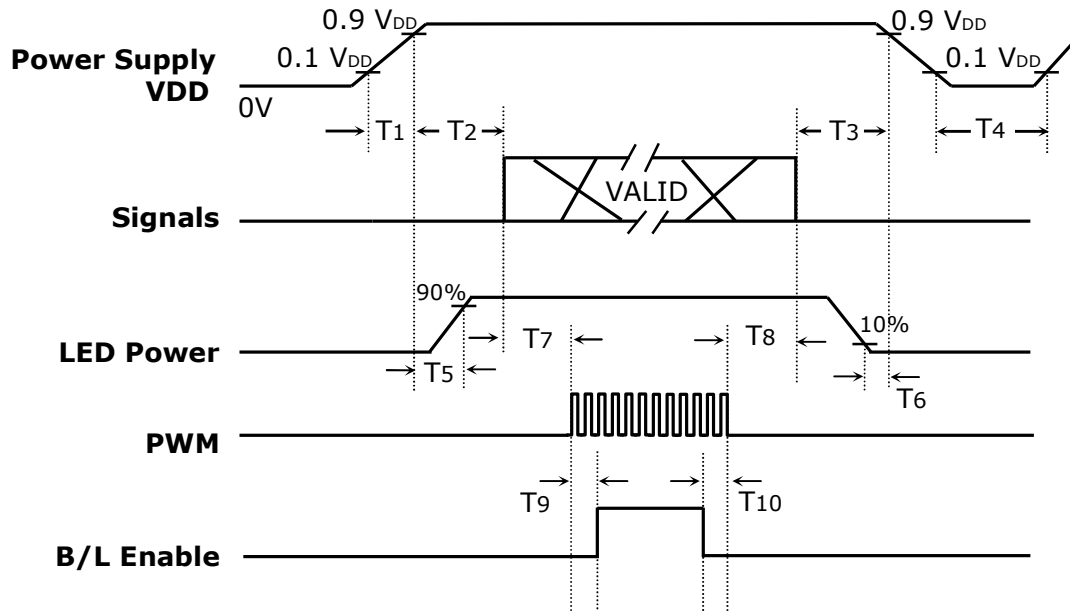

Power ON/OFF Sequence

Timing (ms)	Remarks
$0.5 < T_1 \leq 10$	V _{DD} rising time from 10% to 90%
$0 < T_2 \leq 50$	Delay from V _{DD} to valid data at power ON
$0 < T_3 \leq 50$	Delay from valid data OFF to V _{DD} off at power OFF
$500 \leq T_4$	V _{DD} OFF time for Windows restart
$0 < T_5 \leq T_2$	Delay from V _{DD} ON to LED driver power ON
$0 < T_6 \leq T_3$	Delay from LED driver power OFF to V _{DD} OFF
$0 < T_7$	Delay from valid data to PWM ON
$0 < T_8$	Delay from PWM OFF to valid data OFF
$0 < T_9$	Delay from PWM ON to B/L Enable ON
$0 < T_{10}$	Delay from B/L Enable Off to PWM OFF

Power Sequence & Timing Parameters

Samsung Secret

6.3 Power ON/OFF Sequence

Preliminary

NOTE.

- (1) The supply voltage of the external system for the module input should be the same as the definition of VDD.
- (2) Apply the B/L operation voltage within the LCD operation range. When the back-light turns on before the LCD operation or the LCD turns off before the back-light turns off, the display may momentarily become white.
- (3) In case of VDD = off level, please keep the level of input signals on the low or keep a high impedance.
- (4) T4 should be measured after the module has been fully discharged between power off and on period.
- (5) Interface signal shall not be kept at high impedance when the power is on.
- (6) EN must be turned on late than VDD and PWM signal.
EN must be turned off early than VDD and and PWM signal.

Samsung Secret

Doc.No.	LTN140AT02-C	Rev.No	04-P01-S-090213	Page	21 / 27
----------------	--------------	---------------	-----------------	-------------	---------

7. Mechanical Outline Dimension

Preliminary

It will be attached with PDF file

Samsung Secret

Doc.No.	LTN140AT02-C	Rev.No	04-P01-S-090213	Page	22 / 27
----------------	--------------	---------------	-----------------	-------------	---------

NO	PART NAME	CODE NO	SPECIFICATION	Q'TY	WEIGHT		REMARK
					FINISH	MATERIAL	

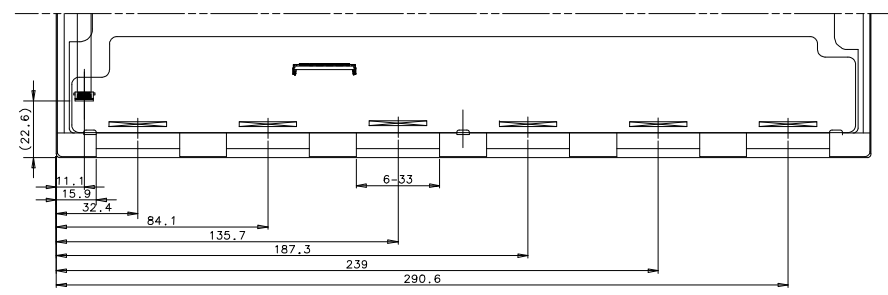
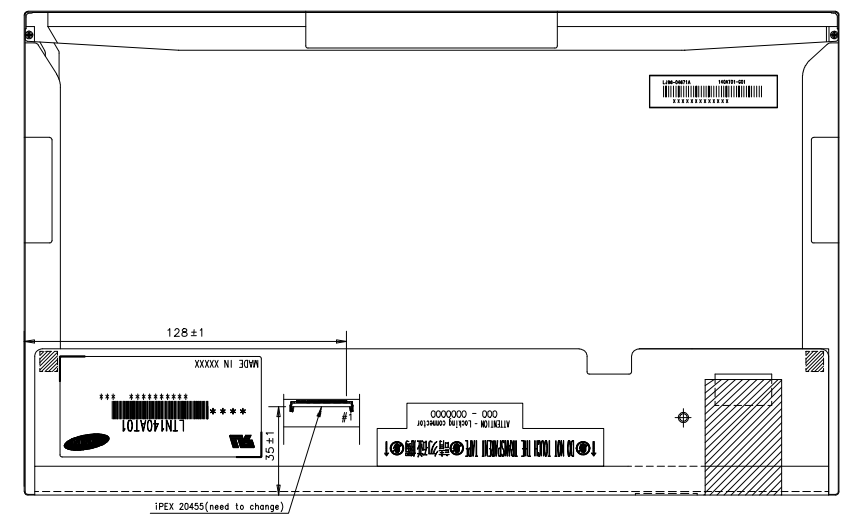
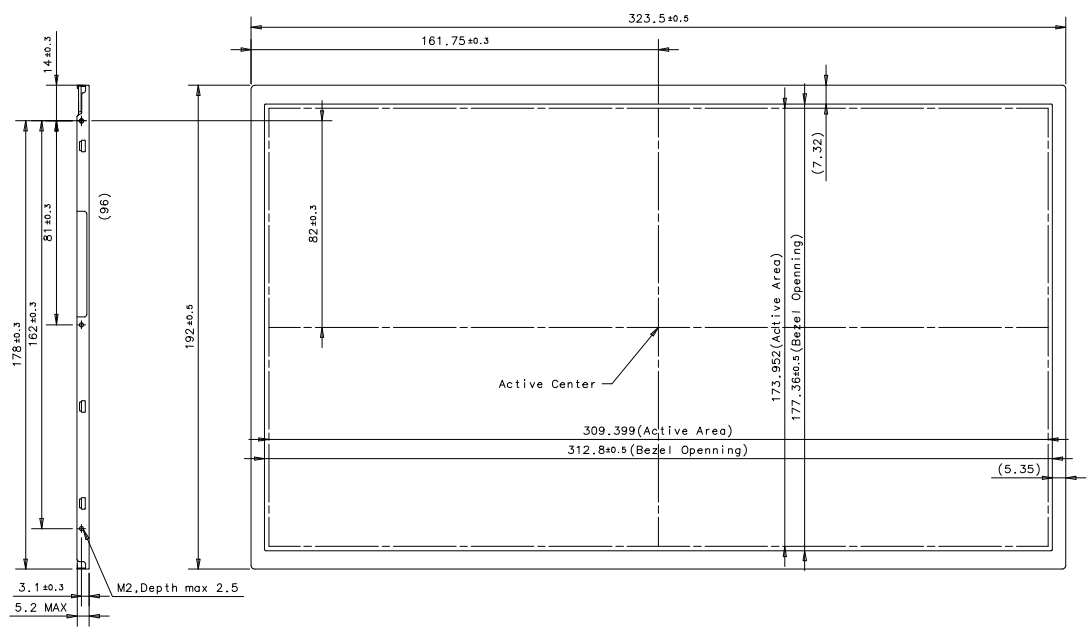

- * NOTE
1. ALLOWED DEPTH OF USERHOLE SCREW INSERTION IS 2.5mm MAX.
 2. MAXIMUM SCREW TORQUE SPEC : 2.5kgf-cm Max
 3. MODULE WEIGHT SPEC : 350g MAX
 4. MEASURING FORCE : 750 +/- 250gf-cm

NO-0-0-V-FR

REV	DATE	DESCRIPTION OF REVISION	REASON	CHK'D BY

UNIT	mm	DRA'N BY	DES'D BY	CHK'D BY	APP'D BY	MODEL NAME	PART/SHEET NAME LTN140AT02	SHEET 1/1
SCALE	1/1	H.S.DHR						
TOLERANCE	±0.3	08.06.17						
SAMSUNG ELECTRONICS							SPEC. NO	
							CODE NO.	
								VER. 000

8. PACKING

1. CARTON(Internal Package)

(1) Packing Form

Corrugated Cardboard box and Corrupad form as shock absorber

(2) Packing Method

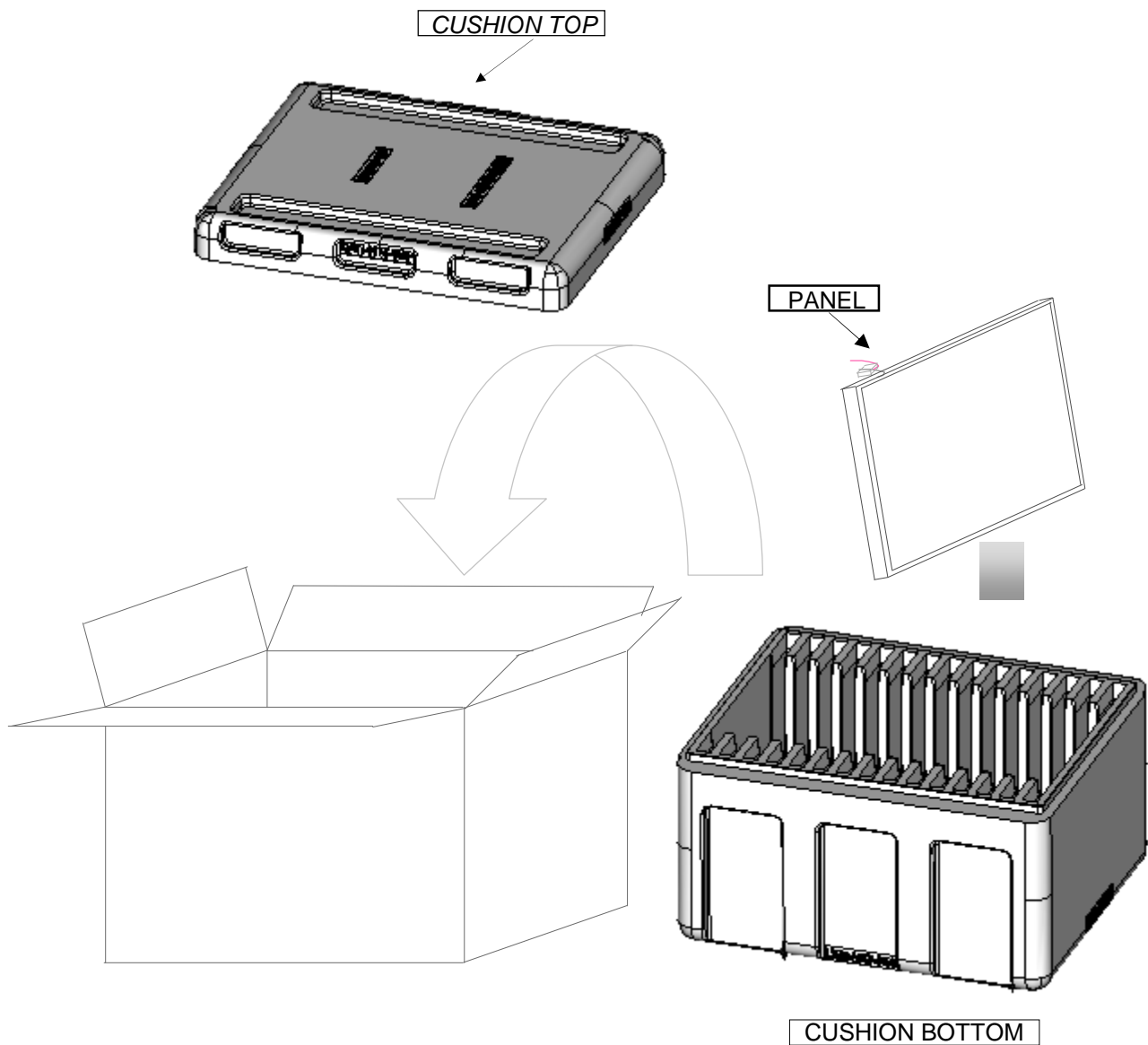

- Note 1) Total Weight : Approximately 5.0 kg
 2) Acceptance number of piling : 30 sets
 3) Carton size : 408(W) * 325(D) * 294(H)

Samsung Secret

Doc.No.	LTN140AT02-C	Rev.No	04-P01-S-090213	Page	23 / 27
---------	--------------	--------	-----------------	------	---------

No	Part name	Quantity
1	Static electric protective sack	30
2	Packing case (Inner box) included shock absorber	1 set
3	Pictorial marking	2 pcs
4	Carton	1 set

9. MARKINGS & OTHERS

A nameplate bearing followed by is affixed to a shipped product at the specified location on each product.

- (1) Parts number : LTN140AT02-G01
- (2) Revision : Three letters
- (3) Lot number : 6 J 7 F XXX XX X

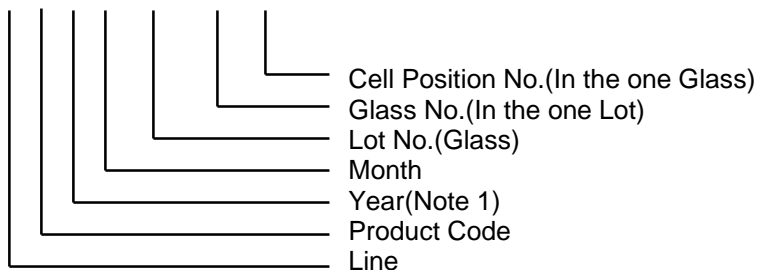

NOTE 1). This code indicating year is omitted in the products of KIHENG site.

(4) Nameplate Indication

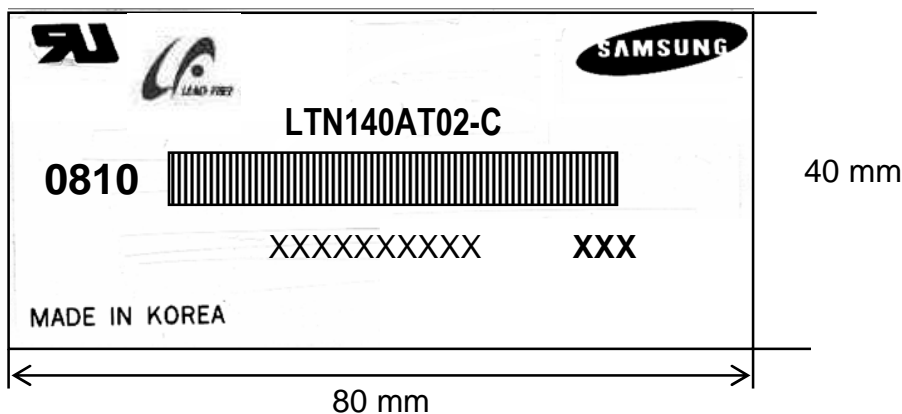

Parts name : LTN140AT02-C
 Lot number : XXXXXXXXXXXX
 Inspected work week : 0810(2008 year 10th week)
 Product Revision Code : **XXX**

Samsung Secret

This HIGH VOLTAGE CAUTION is carved in mold frame

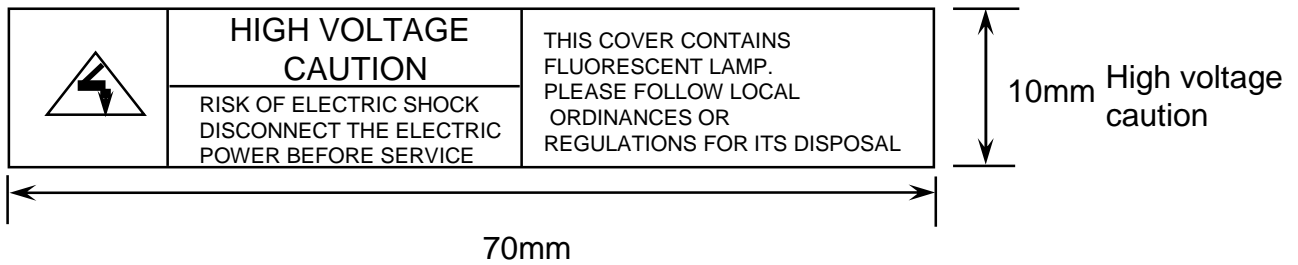

(6) Packing box attach

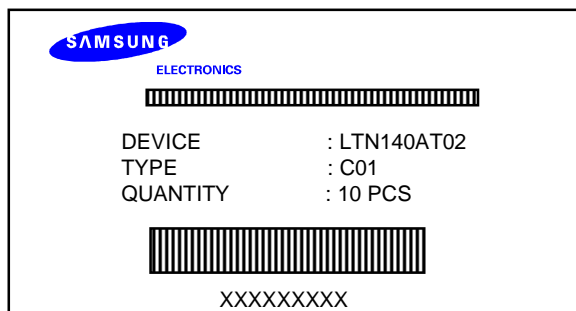

(7) Packing box Marking : Samsung TFT-LCD Brand Name



Samsung Secret

10. GENERAL PRECAUTIONS

Preliminary

1. Handling

- (a) When the module is assembled, It should be attached to the system firmly using every mounting holes. Be careful not to twist and bend the modules.
- (b) Refrain from strong mechanical shock and / or any force to the module. In addition to damage, this may cause improper operation or damage to the module and CCFT back-light.
- (c) Note that polarizers are very fragile and could be easily damaged. Do not press or scratch the surface harder than a HB pencil lead.
- (d) Wipe off water droplets or oil immediately. If you leave the droplets for a long time, Staining and discoloration may occur.
- (e) If the surface of the polarizer is dirty, clean it using some absorbent cotton or soft cloth.
- (f) The desirable cleaners are water, IPA (Isopropyl Alcohol) or Hexane. Do not use Ketone type materials(ex. Acetone), Ethyl alcohol, Toluene, Ethyl acid or Methyl chloride. It might permanent damage to the polarizer due to chemical reaction.
- (g) If the liquid crystal material leaks from the panel, it should be kept away from the eyes or mouth. In case of contact with hands, legs or clothes, it must be washed away thoroughly with soap.
- (h) Protect the module from static, it may cause damage to the C-MOS Gate Array IC.
- (i) Use fingerstalls with soft gloves in order to keep display clean during the incoming inspection and assembly process.
- (j) Do not disassemble the module.
- (k) Do not pull or fold the lamp wire.
- (l) Do not adjust the variable resistor which is located on the back side.
- (m) Protection film for polarizer on the module shall be slowly peeled off just before use so that the electrostatic charge can be minimized.
- (n) Pins of I/F connector shall not be touched directly with bare hands.

Samsung Secret

Doc.No.	LTN140AT02-C	Rev.No	04-P01-S-090213	Page	26 / 27
----------------	--------------	---------------	-----------------	-------------	---------

2. STORAGE

- (a) Do not leave the module in high temperature, and high humidity for a long time.
It is highly recommended to store the module with temperature from 0 to 35 °C and relative humidity of less than 70%.
- (b) Do not store the TFT-LCD module in direct sunlight.
- (c) The module shall be stored in a dark place. It is prohibited to apply sunlight or fluorescent light during the store.

3. OPERATION

- (a) Do not connect, disconnect the module in the “ Power On” condition.
- (b) Power supply should always be turned on/off by following item 6.3
“ Power on/off sequence “.
- (c) Module has high frequency circuits. Sufficient suppression to the electromagnetic interference shall be done by system manufacturers. Grounding and shielding methods may be important to minimize the interference.
- (d) The cable between the back-light connector and its inverter power supply shall be a minimized length and be connected directly . The longer cable between the back-light and the inverter may cause lower luminance of lamp(CCFT) and may require higher startup voltage (Vs).
- (e) The standard limited warranty is only applicable when the module is used for general notebook applications. If used for purposes other than as specified, SEC is not to be held reliable for the defective operations. It is strongly recommended to contact SEC to find out fitness for a particular purpose.

4. OTHERS

- (a) Ultra-violet ray filter is necessary for outdoor operation.
- (b) Avoid condensation of water. It may result in improper operation or disconnection of electrode.
- (c) Do not exceed the absolute maximum rating value. (the supply voltage variation, input voltage variation, variation in part contents and environmental temperature, so on)
Otherwise the module may be damaged.
- (d) If the module displays the same pattern continuously for a long period of time, it can be the situation when the image “sticks” to the screen.
- (e) This module has its circuitry PCB's on the rear side and should be handled carefully in order not to be stressed.

Samsung Secret

Doc.No.	LTN140AT02-C	Rev.No	04-P01-S-090213	Page	27 / 27
----------------	--------------	---------------	-----------------	-------------	---------