

SAMSUNG

ELECTRONICS

Approval



TO : Lenovo

DATE : Nov, 13, 2009

SAMSUNG TFT-LCD**MODEL NO. : LTN140AT07-K02**

NOTE : Extension code [-K02]
 → LTN140AT07-K02
 - Surface type [**Glare**]

Any Modification of Specification is not allowed without SEC's Permission.

APPROVED BY : **Manki - Lee**

PREPARED BY : LCD Customer Satisfaction Part , TCS Team

SAMSUNG ELECTRONICS CO., LTD.**Samsung Secret**

Doc.No.	LTN140AT07-K02	Rev.No	04-A01-G-091111	Page	1 / 30
---------	----------------	--------	-----------------	------	--------

CONTENTS

Approval

Revision History	----- (3)
General Description	----- (4)
1. Absolute Maximum Ratings	----- (5)
1.1 Absolute Ratings of environment	
1.2 Electrical Absolute Ratings	
2. Optical Characteristics	----- (7)
3. Electrical Characteristics	----- (10)
3.1 TFT LCD Module	
3.2 LED Driver	
4. Block Diagram	----- (13)
4.1 TFT LCD Module	
4.2 LED connection and placement	
5. Input Terminal Pin Assignment	----- (14)
5.1 Input Signal & Power	
5.2 LVDS Interface	
5.3 Timing Diagrams of LVDS For Transmitting	
5.4 Input Signals, Basic Display Colors and Gray Scale of Each Color.	
5.5 Pixel format	
6. Interface Timing	----- (19)
6.1 Timing Parameters	
6.2 Timing Diagrams of interface Signal	
6.3 Power ON/OFF Sequence	
7. Outline Dimension	----- (21)
8. Packing	----- (23)
9. Markings & Others	----- (24)
10. General Precautions	----- (26)

Samsung Secret

REVISION HISTORY

Approval

Date	Rev. No.	Page	Summary
Dec. 26. 2008	P00	All	. The preliminary specification was first issued.
Jan.14.2009	P01	- 12 19	. Model name was fixed. -Back light unit was updated - Interface Timing was updated
March.10.2009	P02	22 28	. Outline was updated. . EDID was updated
March.24.2009	P03	22	. Outline was updated. (The position of label was changed)
July.10. 2009	P04	28~30	. EDID was updated
July.28.2009	P05	12 23-25	. Back light unit was updated. . Packing was updated.
Aug.17.2009	P06	24	- Product Label Definition was updated.
Oct. 29 . 2009	A00	22	. Outline was updated. (Add 4pcs sponge position & Max thickness 5.2 → 5.4)
Nov. 11 . 2009	A01	1,4,24, 25,28, 29,30	. Module code changed. EDID data was changed.
www.panelook.com			
<div style="border: 1px solid gray; padding: 2px; display: inline-block; color: red; font-weight: bold;">Samsung Secret</div>			
Doc.No.	LTN140A107-K02		Rev.No
			04-A01-G-091111
	Page	3 / 30	

Approval

GENERAL DESCRIPTION

DESCRIPTION

LTN140AT07-K02 is a color active matrix TFT (Thin Film Transistor) liquid crystal display (LCD) that uses amorphous silicon TFT as a switching devices. This model is composed of a TFT LCD panel, a driver circuit and a backlight unit. The resolution of a 14.0" contains 1,366 x 768 pixels and can display up to 262,144 colors. 6 O'clock direction is the Optimum viewing angle.

FEATURES

- High contrast ratio, high aperture structure
- 1366 x 768 pixels resolution
- Low power consumption
- Fast Response
- LED BLU with LED driver
- 60% Color Gamut
- DE(Data enable) only mode
- 3.3V LVDS Interface
- Onboard EEDID chip
- Pb-free product

APPLICATIONS

- Notebook PC
- If the usage of this product is not for PC application, but for others, please contact SEC.

GENERAL INFORMATION

Item	Specification	Unit	Note
Display area	309.4(H) x 173.95(V) (14.0" diagonal)	mm	
Driver element	a-Si TFT active matrix		
Display colors	262,144		
Number of pixel	1366 x RGB(3) x 768	pixel	16 : 9
Pixel arrangement	RGB vertical stripe		
Pixel pitch	0.2265(H) x 0.2265(V) (TYP.)	mm	
Display Mode	Normally white		
Surface treatment	Haze 0, Hard-Coating 3H		

Samsung Secret

Approval

Mechanical Information

Item		Min.	Typ.	Max.	Unit	Note
Module size	Horizontal (H)	323.0	323.5	324	mm	
	Vertical (V)	191.5	192.0	192.5	mm	
	Depth (D)	-	-	5.4	mm	
Weight		-		350	g	

1. ABSOLUTE MAXIMUM RATINGS

1.1 ENVIRONMENTAL ABSOLUTE RATINGS

Item	Symbol	Min.	Max.	Unit	Note
Storage temperate	TSTG	-20	60	°C	(1)
Operating temperate (Temperature of glass surface)	TOPR	0	50	°C	(1)
Shock (non-operating)	Snop	-	240	G	(2),(4)
Vibration (non-operating)	Vnop	-	2.41	G	(3),(4)

Note (1) Temperature and relative humidity range are shown in the figure below.

95 % RH Max. ($40\text{ °C} \geq T_a$)

Maximum wet - bulb temperature at 39 °C or less. ($T_a > 40\text{ °C}$) No condensation

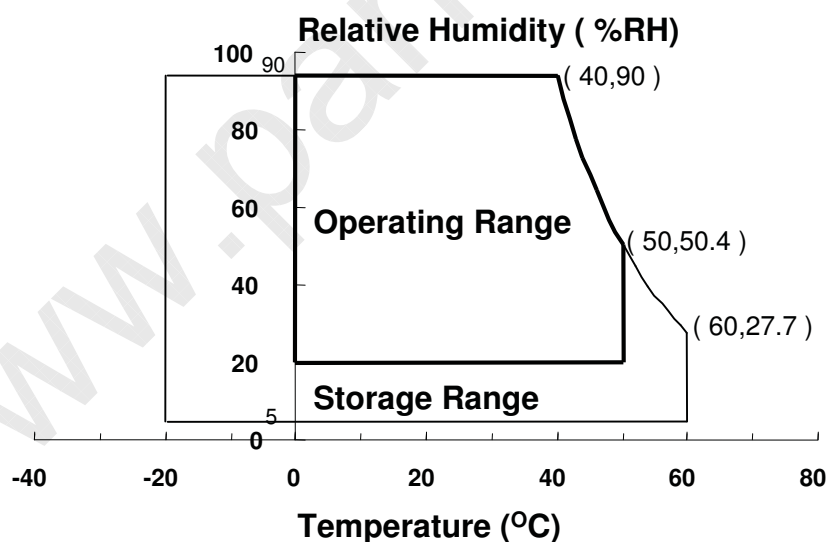

(2) 2ms, half sine wave, one time for $\pm X$, $\pm Y$, $\pm Z$.

(3) 5 - 500 Hz, random vibration, 30min for X, Y, Z.

(4) At testing Vibration and Shock, the fixture in holding the Module to be tested have to be hard and rigid enough so that the Module would not be twisted or bent by the fixture.

Samsung Secret

Approval

1.2 ELECTRICAL ABSOLUTE RATINGS

(1) TFT LCD MODULE

 $V_{DD} = 3.3V$, $V_{SS} = GND = 0V$

Item	Symbol	Min.	Max.	Unit	Note
Power Supply Voltage	V_{DD}	$V_{SS} - 0.3$	3.6	V	(1)

Note (1) Within T_a (25 ± 2 °C)

Samsung Secret

Approval

2. OPTICAL CHARACTERISTICS

The following items are measured under stable conditions. The optical characteristics should be measured in a dark room or equivalent state with the methods shown in Note (5).
Measuring equipment : TOPCON BM-5A and PR-650

* Ta = 25 ± 2 °C, V_{DD}=3.3V, fv= 60Hz, f_{DCLK} = 72.33MHz, IL = 20 mArms

Item	Symbol	Condition	Min.	Typ.	Max	Unit	Note
Contrast Ratio (5 Points)	CR		-	500	-	-	(1), (2), (5)
Response Time at Ta (Rising + Falling)	T _{RT_BW}		-	16	25	msec	(1), (3)
Average Luminance of White (5 Points)	Y _{L,AVE}		190	220	-	cd/m ²	IL=20mA (1), (4)
Color Chromaticity (CIE)	Red	R _X	0.580	0.610	0.640	-	(1), (5) PR-650
		R _Y	0.310	0.340	0.370		
	Green	G _X	0.305	0.335	0.365		
		G _Y	0.560	0.590	0.620		
	Blue	B _X	0.120	0.150	0.180		
		B _Y	0.055	0.085	0.115		
	White	W _X	0.283	0.313	0.343		
		W _Y	0.299	0.329	0.359		
Color Gamut			-	60	-	%	
Viewing Angle	Hor.	θ _L	40	-	-	Degrees	(1), (5) BM-5A
		θ _R	40	-	-		
	Ver.	φ _H	15	-	-		
		φ _L	30	-	-		
13 Points White Variation	δ _L		-	-	1.7	-	(6)

Samsung Secret

Doc.No.

LTN140AT07-K02

Rev.No

04-A01-G-091111

Page

7 / 30

Approval

Note 1) Definition of Viewing Angle : Viewing angle range($10 \leq C/R$, $100 \leq C/R$)

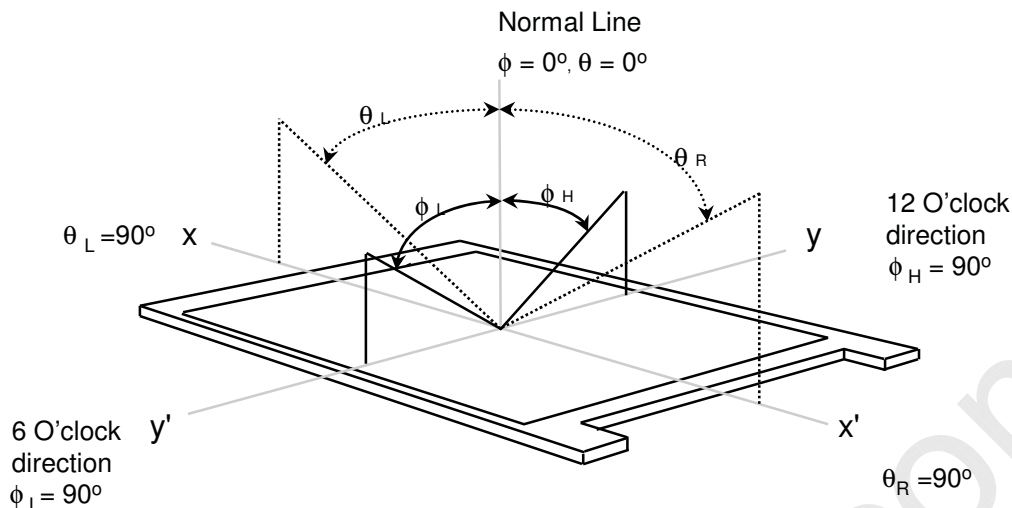

Note 2) Definition of Contrast Ratio (CR) : Ratio of gray max (Gmax) ,gray min (Gmin) at 5 points(4, 5, 7, 9, 10)

$$CR = \frac{CR(4) + CR(5) + CR(7) + CR(9) + CR(10)}{5}$$

Points : (4) , (5) , (7) , (9) , (10) at the figure of Note (6).

Note 3) Definition of Response time :

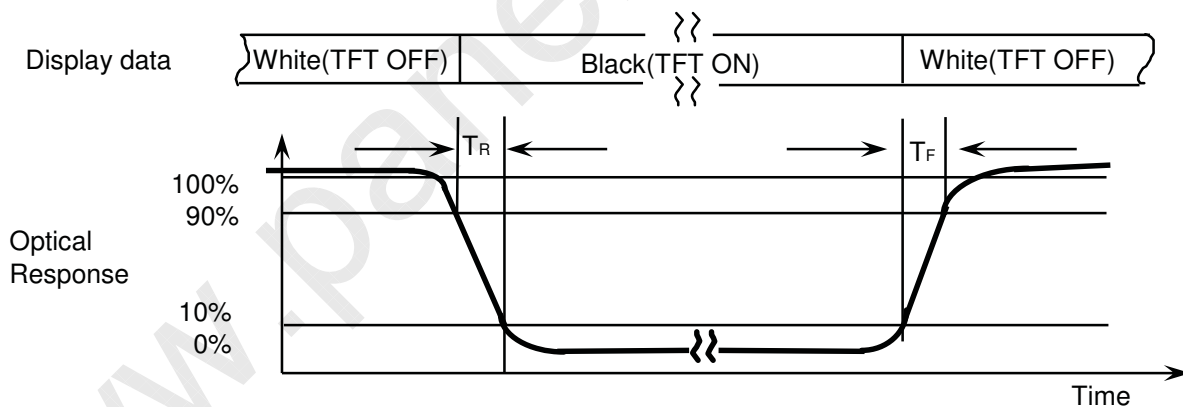

Note 4) Definition of Average Luminance of White : measure the luminance of white at 5 points.

Average Luminance of White ($Y_{L,AVE}$)

$$Y_{L,AVE} = \frac{Y_{L4} + Y_{L5} + Y_{L7} + Y_{L9} + Y_{L10}}{5}$$

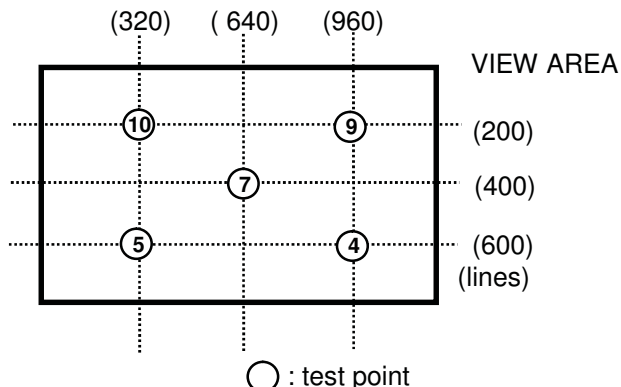

Samsung Secret

Approval

Note 5) After stabilizing and leaving the panel alone at a given temperature for 30 min , the measurement should be executed. Measurement should be executed in a stable, windless, and dark room. 30 min after lighting the backlight. This should be measured in the center of screen. Environment condition : $T_a = 25 \pm 2 \text{ }^\circ\text{C}$

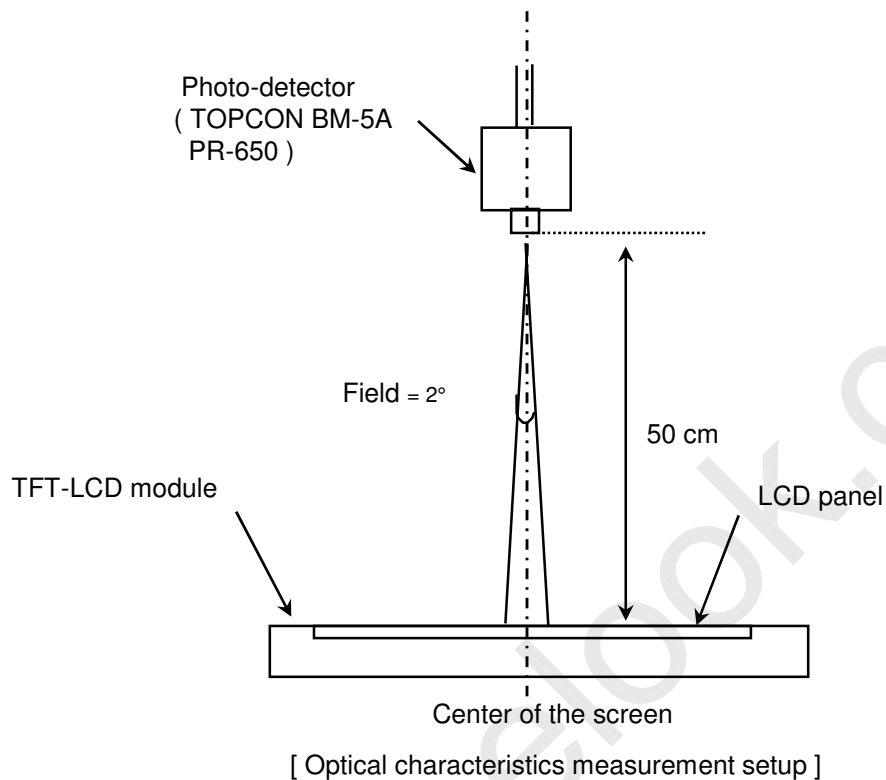

Note 6) Definition of 13 points white variation (δL), CR variation(C_{VER}) [① ~ ⑬]

$$\delta L = \frac{\text{Maximum luminance of 13 points}}{\text{Minimum luminance of 13 points}}$$

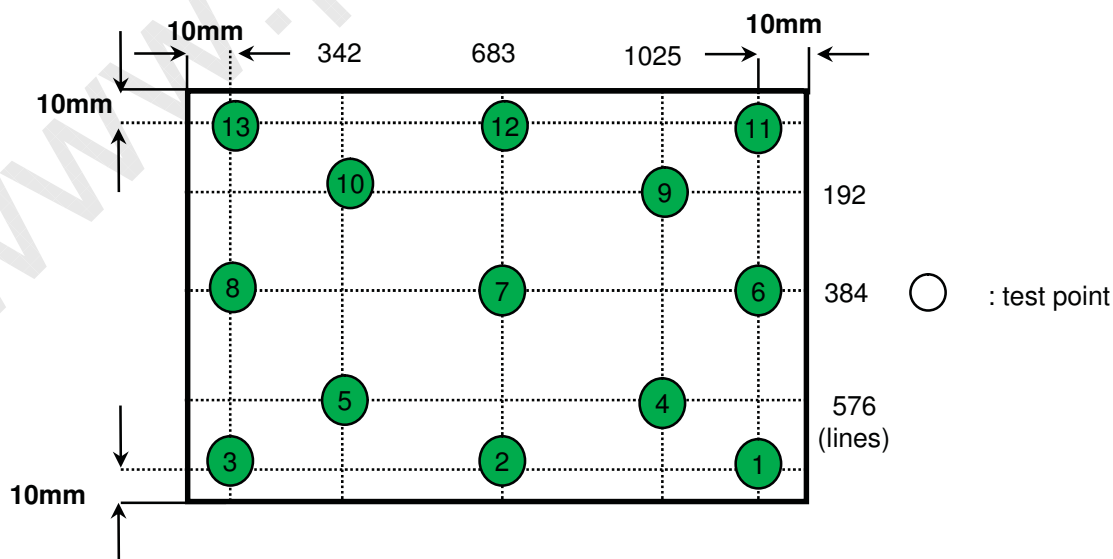

Samsung Secret

Doc.No.	LTN140AT07-K02	Rev.No	04-A01-G-091111	Page	9 / 30
---------	----------------	--------	-----------------	------	--------

3. ELECTRICAL CHARACTERISTICS

Approval

3.1 TFT LCD MODULE

Ta= 25 ± 2°C

Item	Symbol	Min.	Typ.	Max.	Unit	Note	
Voltage of Power Supply	V _{DD}	3.0	3.3	3.6	V		
Differential Input Voltage for LVDS Receiver Threshold	High	V _{IH}	-	-	+100	mV	V _{CM} = +1.2V
	Low	V _{IL}	-100	-	-	mV	
Vsync Frequency	f _v	-	60	-	Hz		
Hsync Frequency	f _H	-	47.4	-	KHz	f _v *790	
Main Frequency	f _{DCLK}	-	72.33	-	MHz	f _H *1526	
Rush Current	I _{RUSH}	-	-	1.5	A	(4)	
Current of Power Supply	White	I _{DD}	-	300	-	mA	(2),(3)*a
	Mosaic		-	350	-	mA	(2),(3)*b
	V. stripe		-	450	485	mA	(2),(3)*c

Note (1) Display data pins and timing signal pins should be connected.(GND = 0V)

(2) f_v = 60Hz, f_{DCLK} = 72.33MHz, V_{DD} = 3.3V , DC Current.

(3) Power dissipation pattern

*a) White Pattern

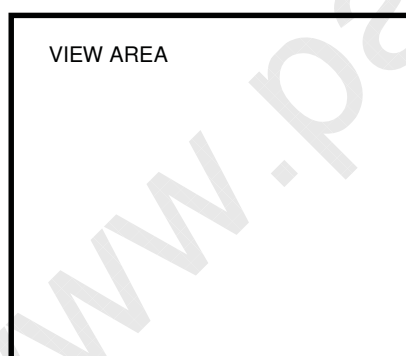

*b) Mosaic Pattern

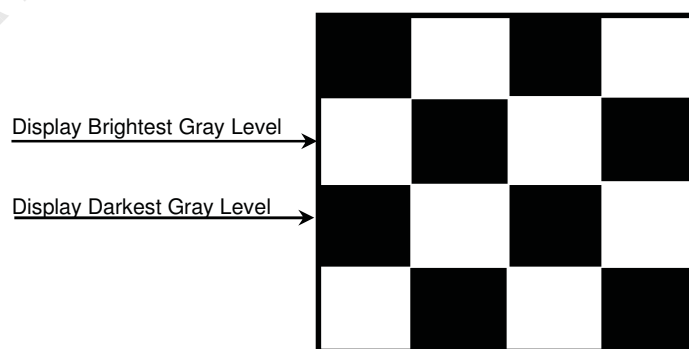

Samsung Secret

Approval

*c) 1dot Vertical stripe pattern

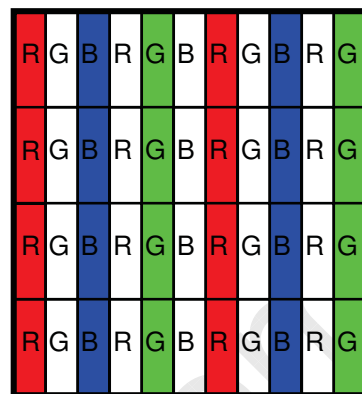
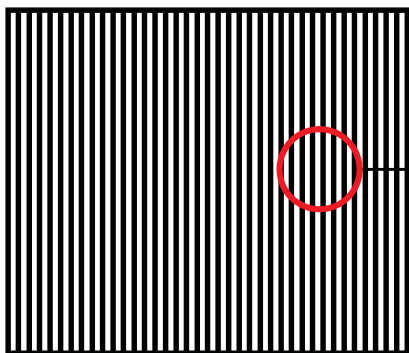

4) Rush current measurement condition

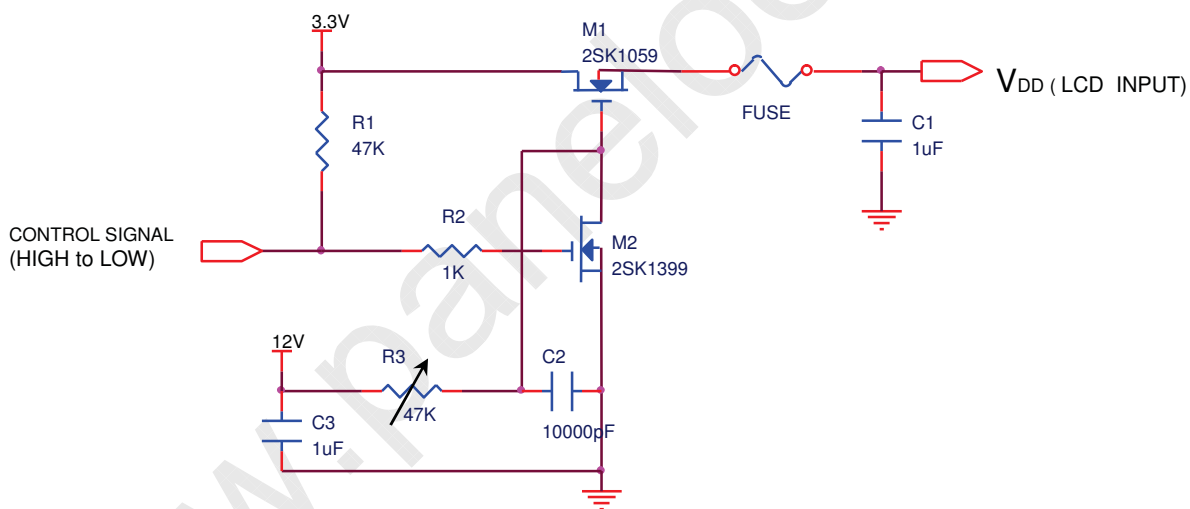

V_{DD} rising time is 470us

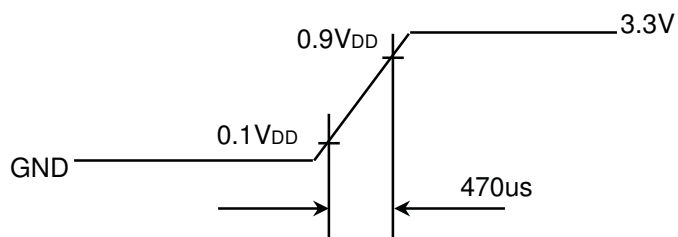

Samsung Secret

Approval

3.2 Back light unit

- LED Driver

Ta= 25 ± 2 °C

Item	Symbol	Min.	Typ.	Max.	Unit	Note
Input Voltage	V _{in}	7	12	21	V	
PWM Duty	P _D	5%	-	100	&	(2)
Operating Frequency	F _o	100		2000	Hz	(1),(2)

Note (1) 50µs minimum BRT on-time limits

(2) If PWM Dimming is min 5%, PWM Freq. is Max 1000Hz

- LED Driver Manufacturer : RICHTEK , LED qty.:7 X 6 = 42 EA

Item	Symbol	Min.	Typ.	Max.	Unit	Note
LED Forward Current	IF	-	20	-	mA	
LED Forward Voltage	VF	3	3.2	3.4	V	IF=20mA
LED Array Voltage	VP	21	22.4	23.8	V	VF X 7 LEDs
Power Consumption	P	3.02	3.23	3.43	W	IF X VF X 42LEDs X1.2 IF=20mA (W/ LED driver)
Operating Life Time	Hr	10,000	-	-	Hr	(1)

Note (1) Life time (Hr) of LEDs can be defined as the time in which it continues to operate under the condition Ta= 25 ± 2 °C and DC = 20.0 mA until one of the following event occurs.

- When the brightness becomes 50% or lower than the original.

Samsung Secret

Approval

4. BLOCK DIAGRAM

4.1 TFT LCD Module

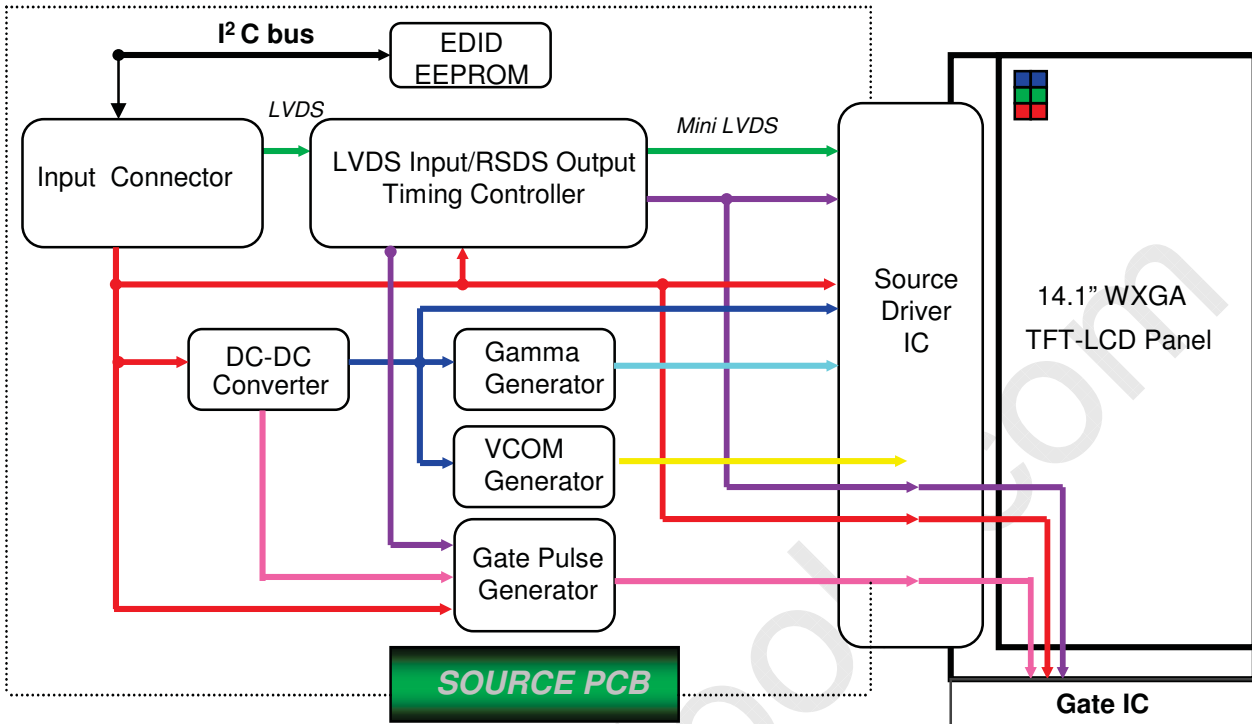

- Video Signal
- Control Signal
- VCOM
- Gamma
- DVDD
- AVDD
- Von/Voff

4.2 LED connection and placement

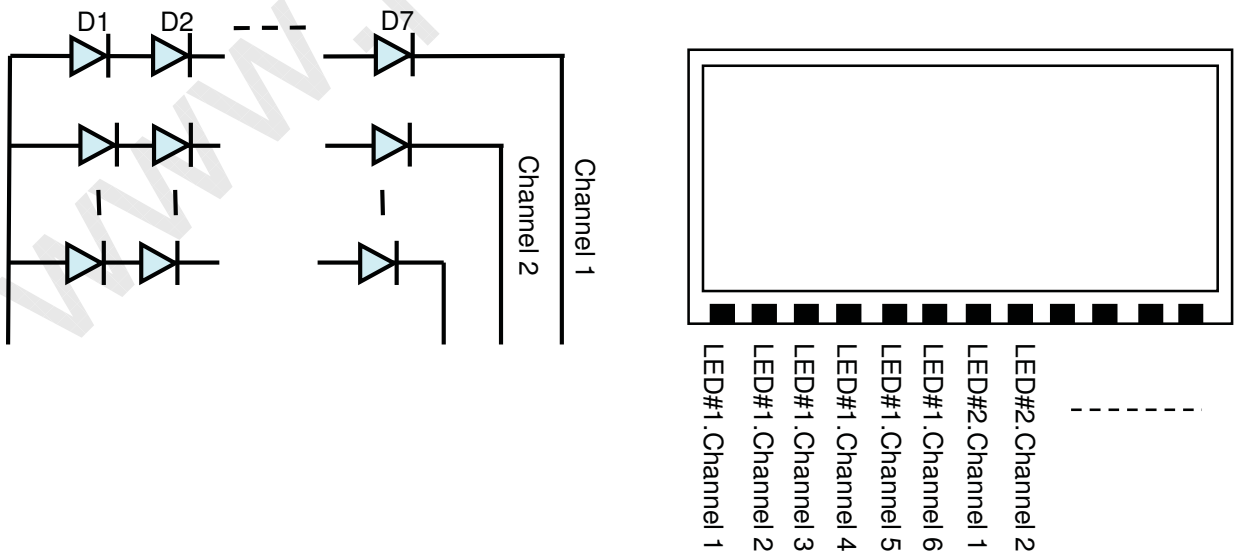

Samsung Secret

Doc.No.	LTN140AT07-K02	Rev.No	04-A01-G-091111	Page	13 / 30
----------------	----------------	---------------	-----------------	-------------	---------

Approval

5. INPUT TERMINAL PIN ASSIGNMENT

5.1. Input Signal & Power

Pin	Symbol	Function
1	NC	No Connection (Reserved for supplier)
2	VCC	Power Supply, 3.3V (typical)
3	VCC	Power Supply, 3.3V (typical)
4	VCC_EDID	DDC 3.3V power
5	NC	No Connection (Reserved for supplier)
6	CLK_EDID	DDC Clock
7	DATA_EDID	DDC Data
8	RXin0-	- LVDS differential data (R0-R5, G0)
9	RXin0+	+ LVDS differential data (R0-R5, G0)
10	GND	Ground
11	RXin1-	- LVDS differential data (G1-G5, B0-B1)
12	RXn1+	+ LVDS differential data (G1-G5, B0-B1)
13	GND	Ground
14	RXin2-	- LVDS differential data (B2-B5,HS,VS, DE)
15	RXn2+	+ LVDS differential data (B2-B5,HS,VS, DE)
16	GND	Ground
17	ClkIN-	- LVDS differential clock input
18	ClkIN+	+ LVDS differential clock input
19	GND	Ground
20~21	NC	No Connection
22	NC	Ground
23~24	NC	No Connection
25	NC	Ground
26~27	NC	No Connection
28	NC	Ground
29~30	NC	No Connection
31~33	VBL-	LED Ground
34	NC	No Connection
35	PWM	PWM for luminance control
36	LED_EN	BL On/Off (On: 2.0~3.3V, Off: 0~0.5V)
37	NC	No Connection
38~40	VBL(7~20)	*LED Power Supply 7V-20V

Samsung Secret

Doc.No.

LTN140AT07-K02

Rev.No

04-A01-G-091111

Page

14 / 30

Approval

5.3 LVDS Interface

Pin No.	Name	RGB Signal	Pin No.	Name	RGB Signal
51	TxIN0	R0	14	TxIN14	G5
52	TxIN1	R1	15	TxIN15	B0
54	TxIN2	R2	19	TxIN18	B1
55	TxIN3	R3	20	TxIN19	B2
56	TxIN4	R4	22	TxIN20	B3
3	TxIN6	R5	23	TxIN21	B4
4	TxIN7	G0	24	TxIN22	B5
6	TxIN8	G1	27	TxIN24	Hsync
7	TxIN9	G2	28	TxIN25	Vsync
11	TxIN12	G3	30	TxIN26	DE
12	TxIN13	G4	31	TxCLKIN	Clock

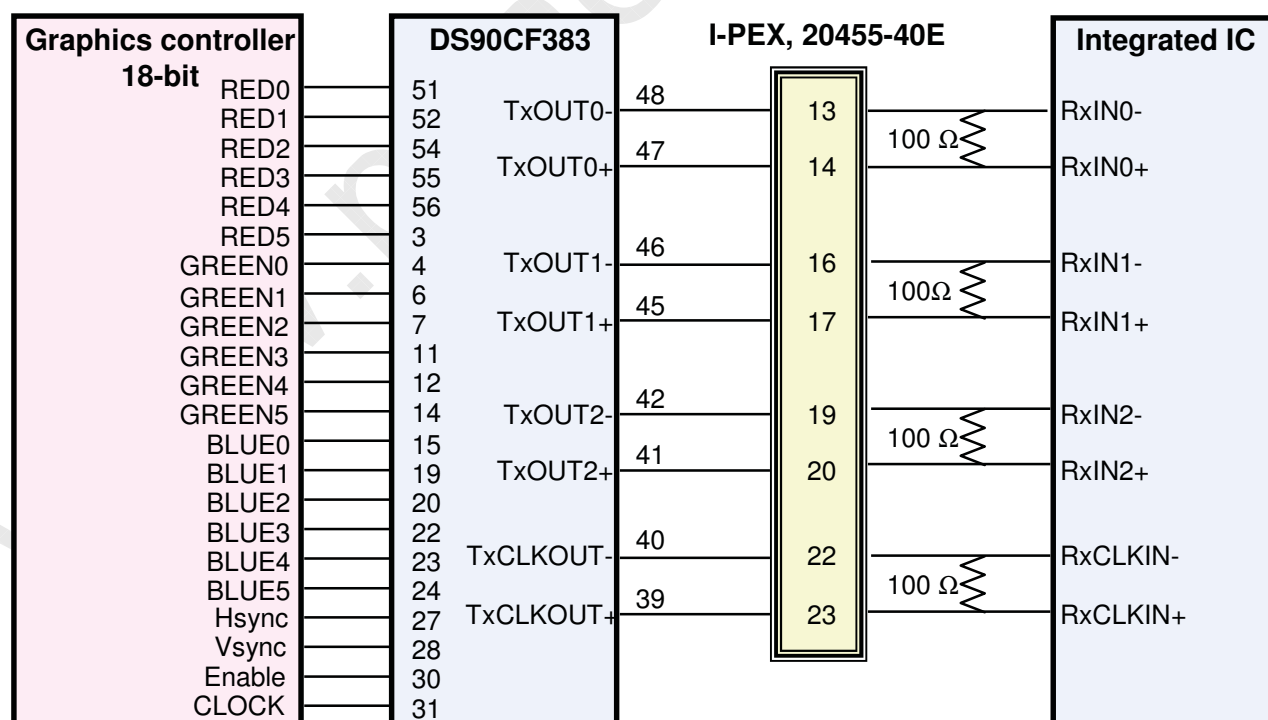
LVDS Interface

Note : The LCD Module uses a 100ohm resistor between positive and negative lines of each receiver input.

Samsung Secret

Doc.No.	LTN140AT07-K02	Rev.No	04-A01-G-091111	Page	15 / 30
---------	----------------	--------	-----------------	------	---------

Approval

5.4 Timing Diagrams of LVDS For Transmission

LVDS Receiver : Integrated T-CON

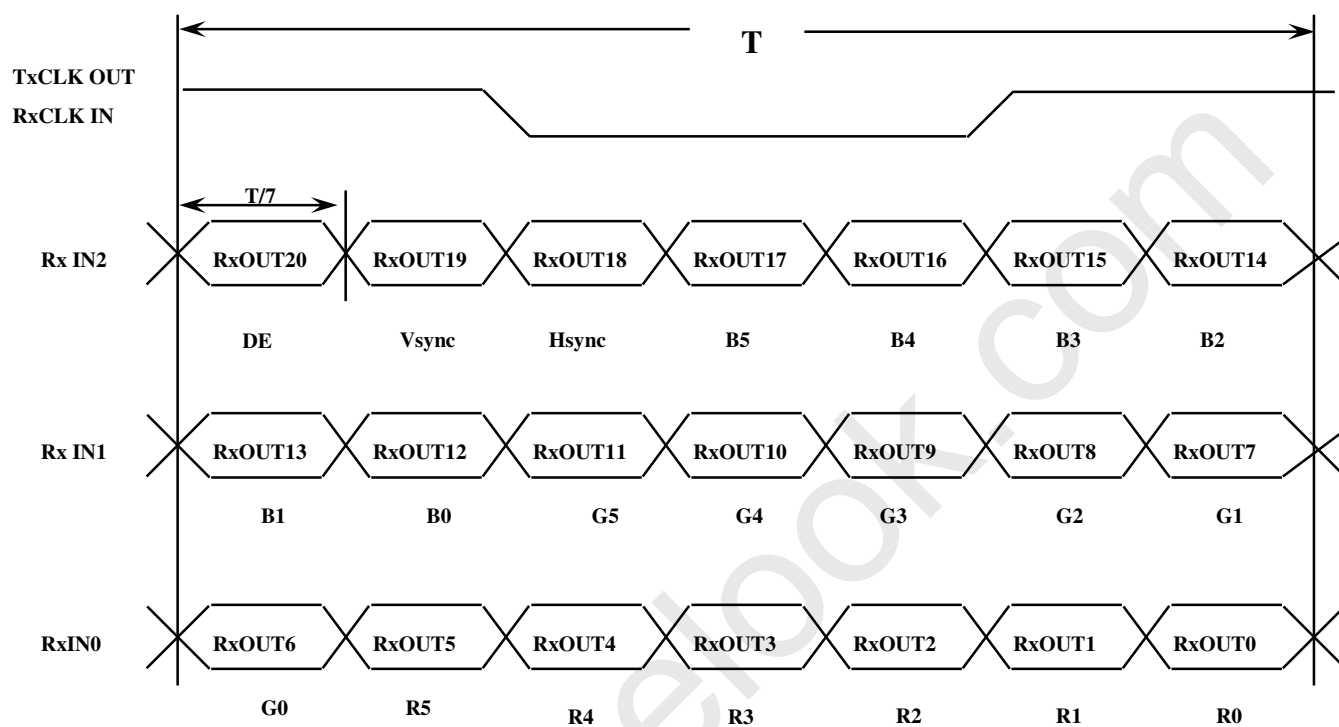

Samsung Secret

Doc.No.

LTN140AT07-K02

Rev.No

04-A01-G-091111

Page

16 / 30

Approval

5.5 Input Signals, Basic Display Colors and Gray Scale of Each Color

Color	Display	Data Signal																Gray Scale Level	
		Red					Green					Blue							
		R0	R1	R2	R3	R4	R5	G0	G1	G2	G3	G4	G5	B0	B1	B2	B3		45
Basic Colors	Black	0	0	0	0	0	0	0	0	0	0	0	0	0	0	0	0	0	-
	Blue	0	0	0	0	0	0	0	0	0	0	0	0	1	1	1	1	1	-
	Green	0	0	0	0	0	0	1	1	1	1	1	1	0	0	0	0	0	-
	Cyan	0	0	0	0	0	0	1	1	1	1	1	1	1	1	1	1	1	-
	Red	1	1	1	1	1	1	0	0	0	0	0	0	0	0	0	0	0	-
	Magenta	1	1	1	1	1	1	0	0	0	0	0	0	1	1	1	1	1	-
	Yellow	1	1	1	1	1	1	1	1	1	1	1	1	0	0	0	0	0	-
	White	1	1	1	1	1	1	1	1	1	1	1	1	1	1	1	1	1	-
Gray Scale Of Red	Black	0	0	0	0	0	0	0	0	0	0	0	0	0	0	0	0	0	R0
	Dark	1	0	0	0	0	0	0	0	0	0	0	0	0	0	0	0	0	R1
	↑	0	1	0	0	0	0	0	0	0	0	0	0	0	0	0	0	0	R2
	:	:	:	:	:	:	:	:	:	:	:	:	:	:	:	:	:	:	R3~R60
	:	:	:	:	:	:	:	:	:	:	:	:	:	:	:	:	:	:	
	↓	1	0	1	1	1	1	0	0	0	0	0	0	0	0	0	0	0	R61
	Light	0	1	1	1	1	1	0	0	0	0	0	0	0	0	0	0	0	R62
	Red	1	1	1	1	1	1	0	0	0	0	0	0	0	0	0	0	0	R63
Gray Scale Of Green	Black	0	0	0	0	0	0	0	0	0	0	0	0	0	0	0	0	0	G0
	Dark	0	0	0	0	0	0	1	0	0	0	0	0	0	0	0	0	0	G1
	↑	0	0	0	0	0	0	0	1	0	0	0	0	0	0	0	0	0	G2
	:	:	:	:	:	:	:	:	:	:	:	:	:	:	:	:	:	:	G3~G60
	:	:	:	:	:	:	:	:	:	:	:	:	:	:	:	:	:	:	
	↓	0	0	0	0	0	0	1	0	1	1	1	1	0	0	0	0	0	G61
	Light	0	0	0	0	0	0	0	1	1	1	1	1	0	0	0	0	0	G62
	Green	0	0	0	0	0	0	1	1	1	1	1	1	0	0	0	0	0	G63
Gray Scale Of Blue	Black	0	0	0	0	0	0	0	0	0	0	0	0	0	0	0	0	0	B0
	Dark	0	0	0	0	0	0	0	0	0	0	0	0	1	0	0	0	0	B1
	↑	0	0	0	0	0	0	0	0	0	0	0	0	0	1	0	0	0	B2
	:	:	:	:	:	:	:	:	:	:	:	:	:	:	:	:	:	:	B3~B60
	:	:	:	:	:	:	:	:	:	:	:	:	:	:	:	:	:	:	
	↓	0	0	0	0	0	0	0	0	0	0	0	0	1	0	1	1	1	B61
	Light	0	0	0	0	0	0	0	0	0	0	0	0	0	1	1	1	1	B62
	Blue	0	0	0	0	0	0	0	0	0	0	0	0	1	1	1	1	1	B63

Note 1) Definition of gray :
 Rn: Red gray, Gn: Green gray, Bn: Blue gray (n=gray level)
 Note 2) Input signal: 0 =Low level voltage, 1=High level voltage

Samsung Secret

Approval

5.6 Pixel Format in the display

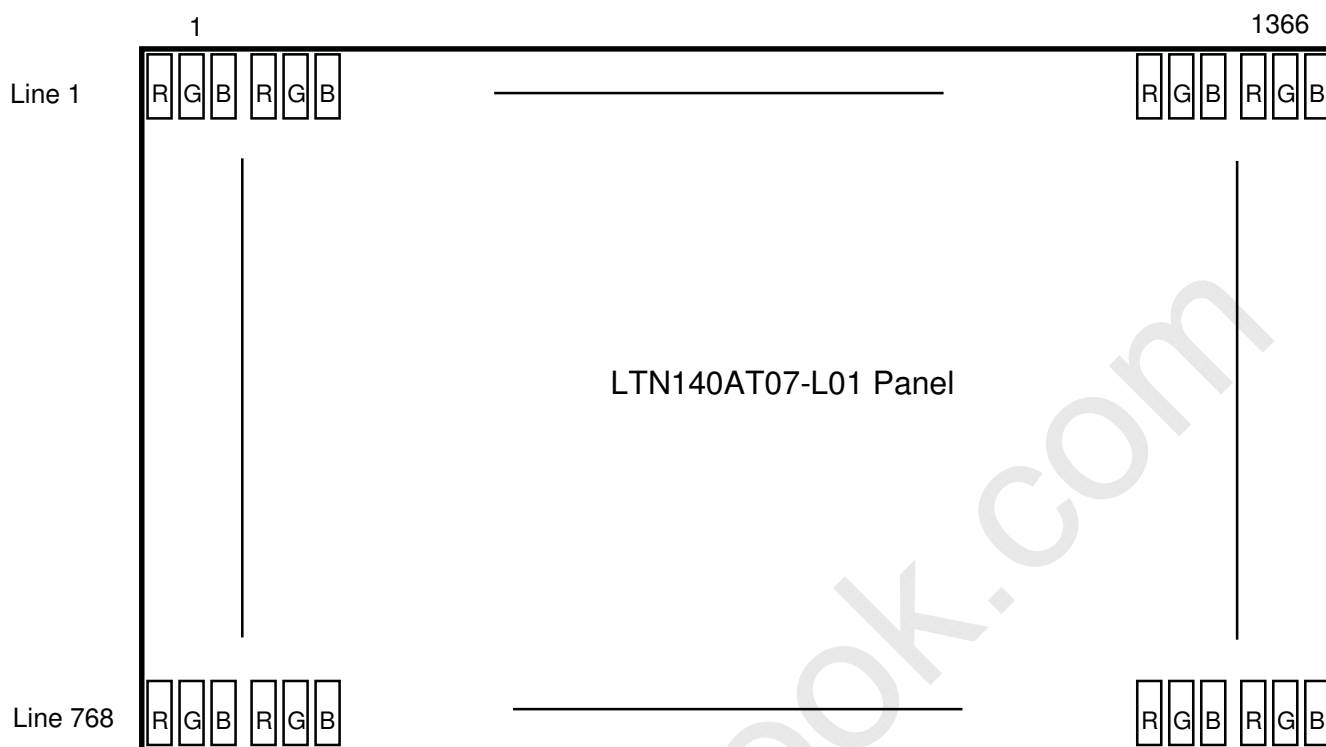

Samsung Secret

Doc.No.

LTN140AT07-K02

Rev.No

04-A01-G-091111

Page

18 / 30

Approval

6. INTERFACE TIMING

6.1 Timing Parameters

Signal	Item	Symbol	Min.	Typ.	Max.	Unit	Note
Frame Frequency	Cycle	T_V	780	790	980	Lines	
Vertical Active Display Term	Display Period	T_{VD}	-	768	-	Lines	
One Line Scanning Time	Cycle	T_H	1440	1526	1800	Clocks	
Horizontal Active Display Term	Display Period	T_{HD}	-	1366	-	Clocks	

6.2 Timing diagrams of interface signal

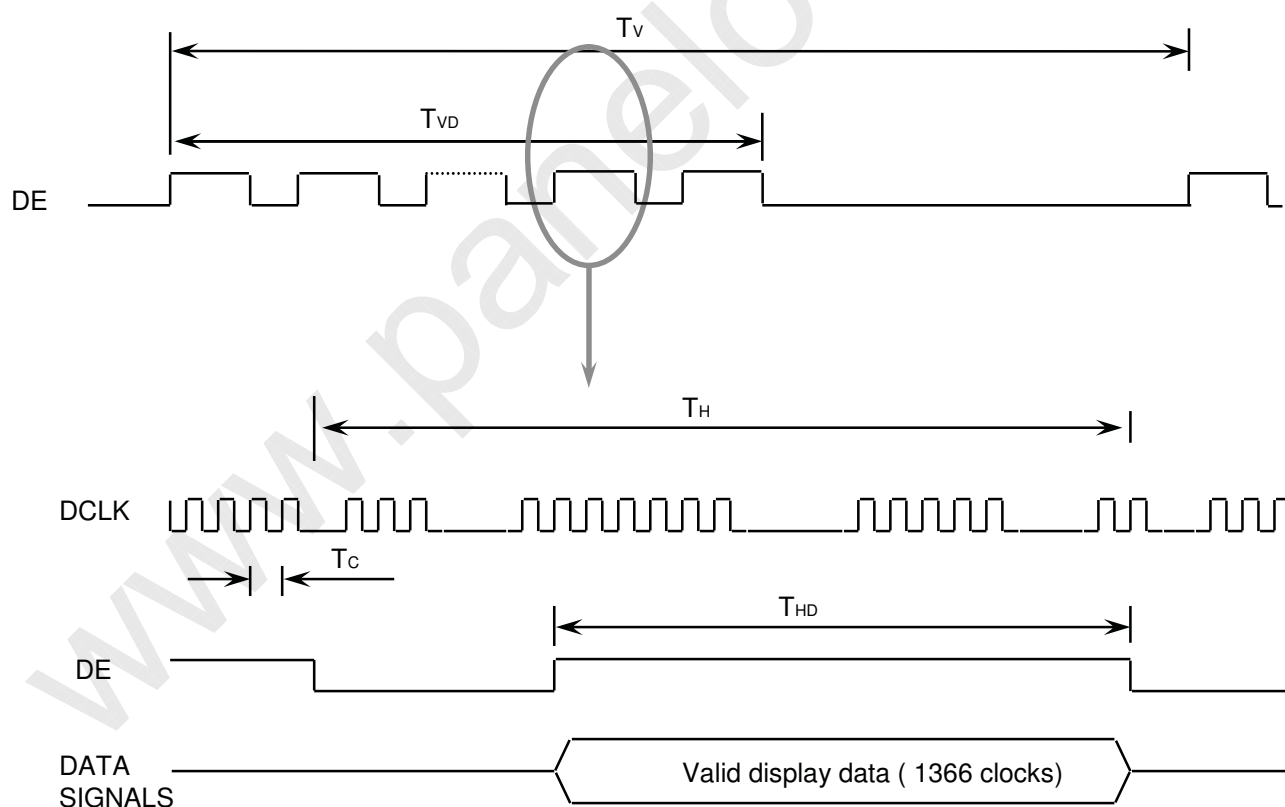

Samsung Secret

Doc.No.

LTN140AT07-K02

Rev.No

04-A01-G-091111

Page

19 / 30

6.3 Power ON/OFF Sequence

Approval

: To prevent a latch-up or DC operation of the LCD module, the power on/off sequence should be as the diagram below.

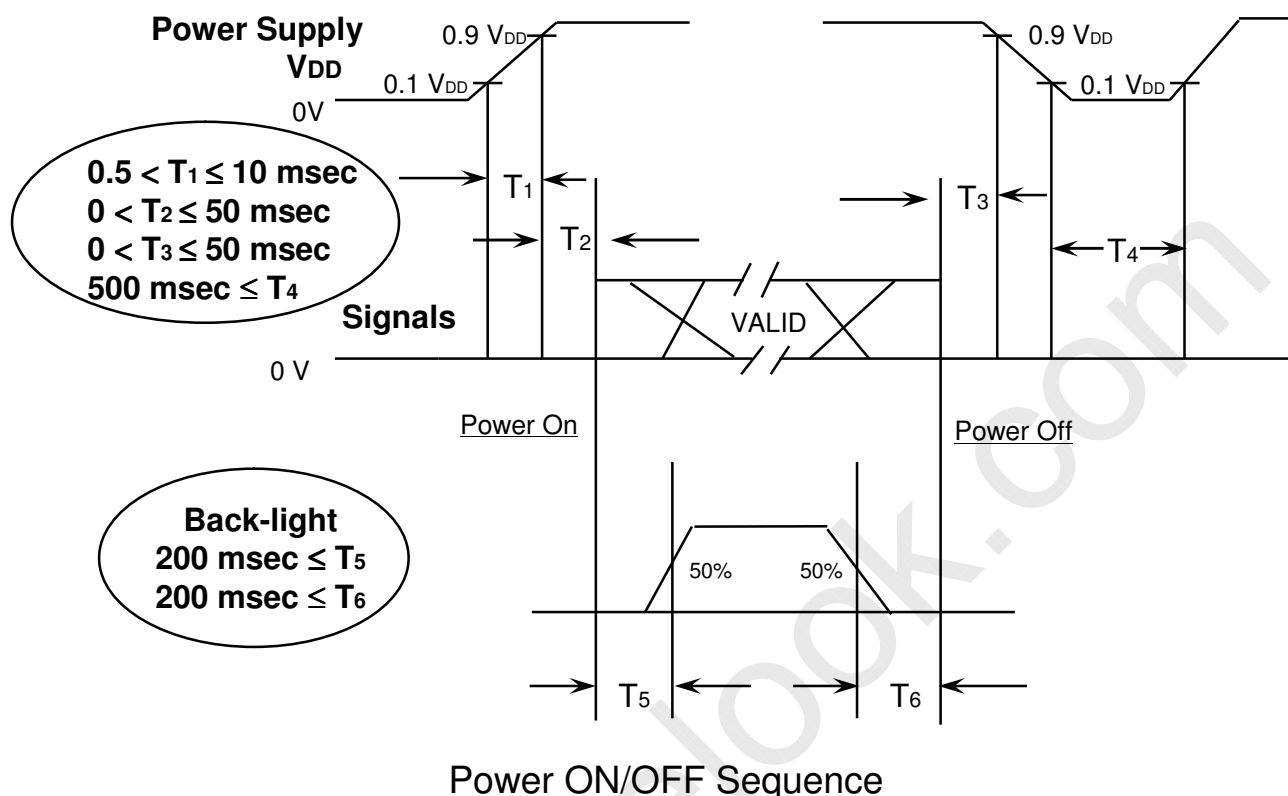

- T1 : Vdd rising time from 10% to 90%
- T2 : The time from Vdd to valid data at power ON.
- T3 : The time from valid data off to Vdd off at power Off.
- T4 : Vdd off time for Windows restart
- T5 : The time from valid data to B/L enable at power ON.
- T6 : The time from valid data off to B/L disable at power Off.

NOTE.

- (1) The supply voltage of the external system for the module input should be the same as the definition of V_{DD} .
- (2) Apply the lamp voltage within the LCD operation range. When the back-light turns on before the LCD operation or the LCD turns off before the back-light turns off, the display may momentarily become white.
- (3) In case of $V_{DD} = \text{off level}$, please keep the level of input signals on the low or keep a high impedance.
- (4) T4 should be measured after the module has been fully discharged between power off and on period.
- (5) Interface signal shall not be kept at high impedance when the power is on.

Samsung Secret

Doc.No.	LTN140AT07-K02	Rev.No	04-A01-G-091111	Page	20 / 30
---------	----------------	--------	-----------------	------	---------



7. Mechanical Outline Dimension

Approval

It will be attached with PDF file

www.panelook.com

Samsung Secret

Doc.No.	LTN140AT07-K02	Rev.No	04-A01-G-091111	Page	21 / 30
----------------	----------------	---------------	-----------------	-------------	---------

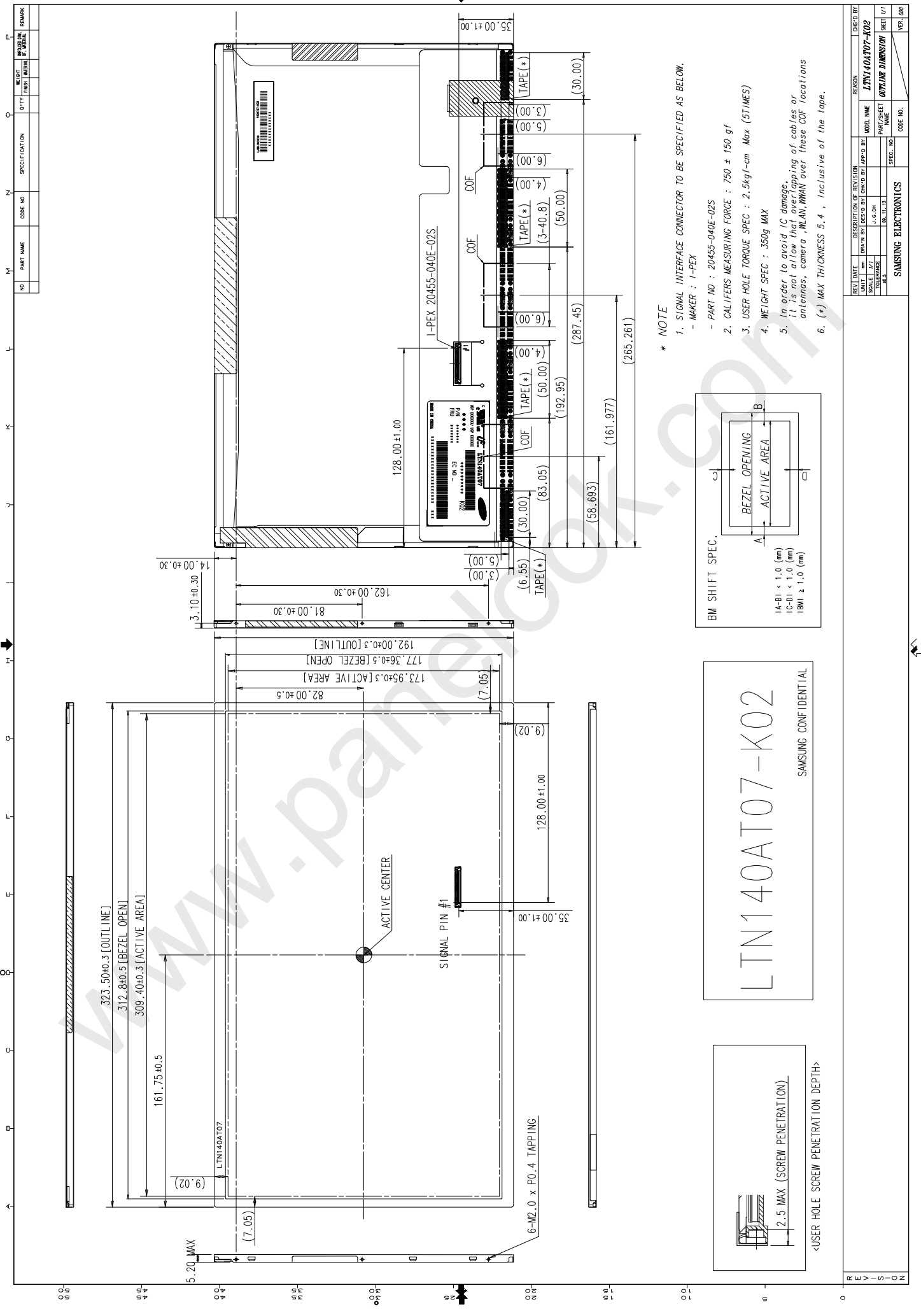

8. PACKING

Approval

1. CARTON(Internal Package)

(1) Packing Form

Corrugated Cardboard box and EPS form as shock absorber

(2) Packing Method

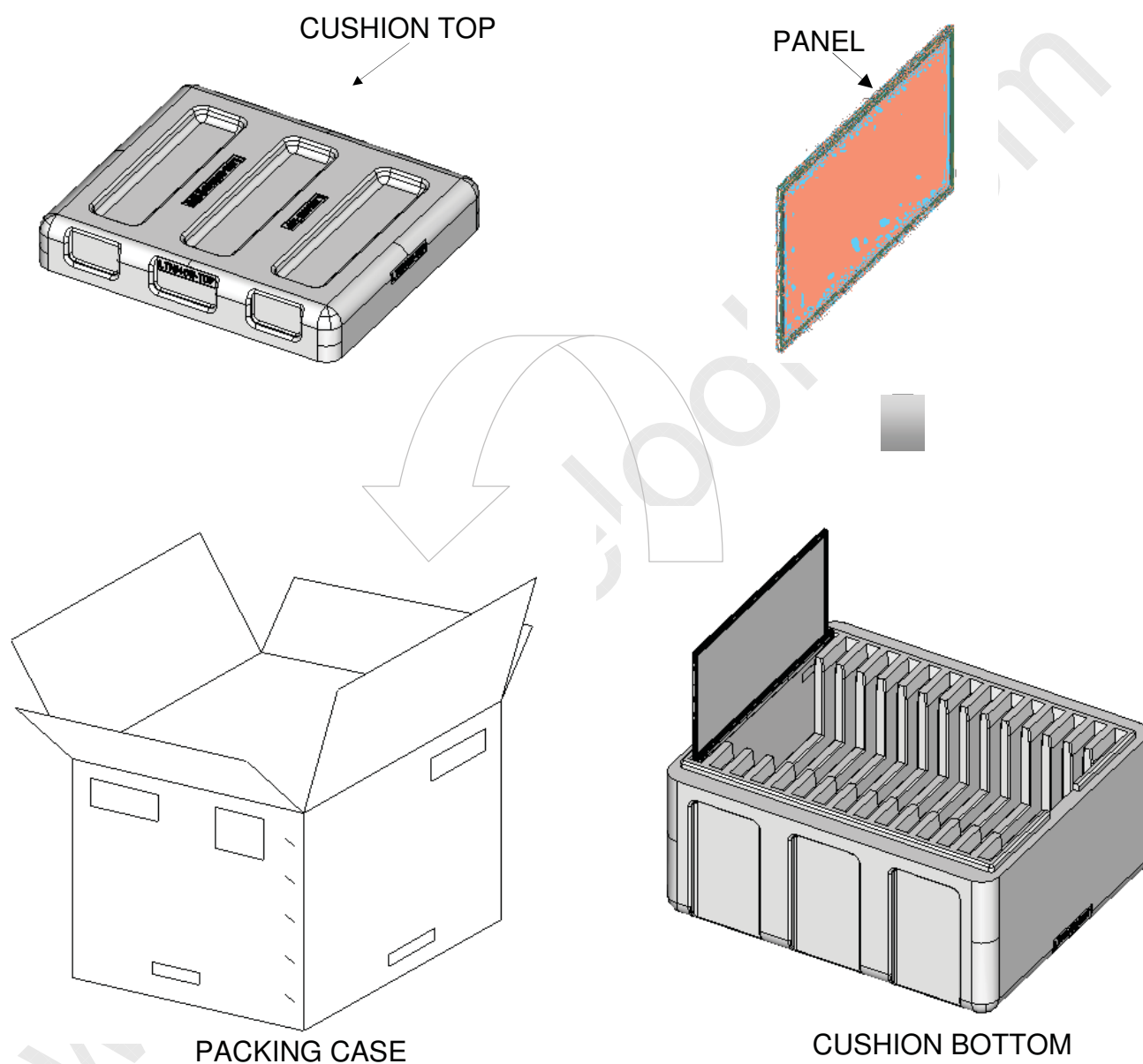

Note 1) Total Weight : Approximately (13.2) kg

2) Acceptance number of piling : 30 sets

3) Carton size : 495(W) x 423(D) x 310 (H)

Samsung Secret

Doc.No.

LTN140AT07-K02

Rev.No

04-A01-G-091111

Page

23 / 30

Approval

(3)Packing Material

No	Part name	Quantity
1	Static electric protective sack	30 pcs
2	Packing case (Inner box) included shock absorber	1 set
3	Pictorial marking	2 pcs
4	Carton	1 set

9. MARKINGS & OTHERS

A nameplate bearing followed by is affixed to a shipped product at the specified location on each product.

(1)Parts number : LTN140AT07

(2)Revision code : 3 letters

(3)Lot number : X X X X XXX XX X K02

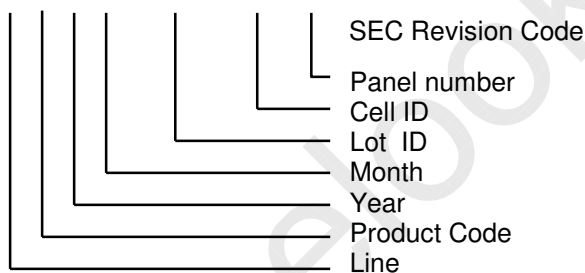

(4) Product Label Definition

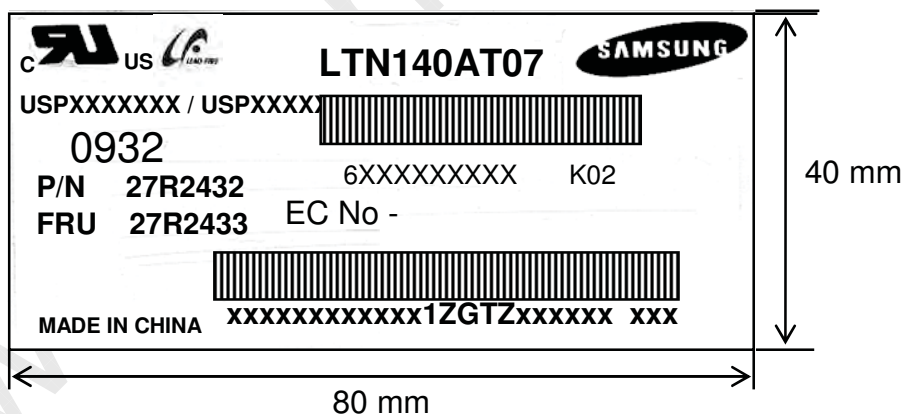

Parts name : LTN140AT07
 Lot number : XXXXXXXXXXXX
 Inspected work week : 0814(2008 year 14th weeks)
 Product Revision Code : K02
 P/N : Lenovo Part Number (27R2432)
 EC NO : Engineering Change Number (Blank)
 FRU : Field Replaceable Unit Part Number(27R2433)
 Header Code : 1ZGTZ

Samsung Secret

Doc.No.	LTN140AT07-K02	Rev.No	04-A01-G-091111	Page	24 / 30
----------------	----------------	---------------	-----------------	-------------	---------

Approval

High voltage caution label

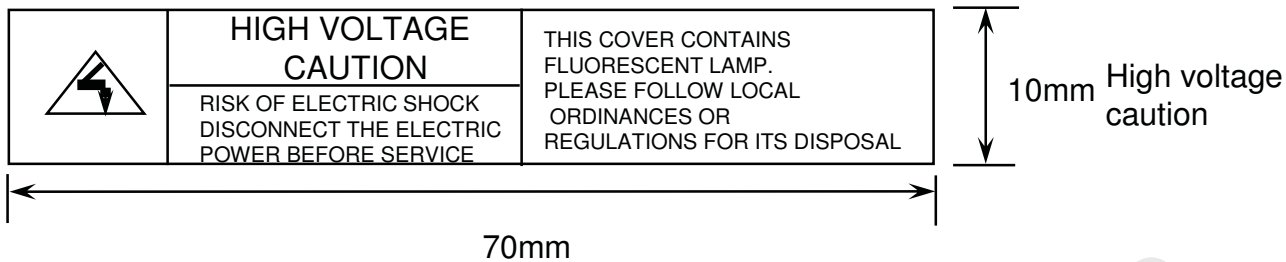

(5) Packing small box attach

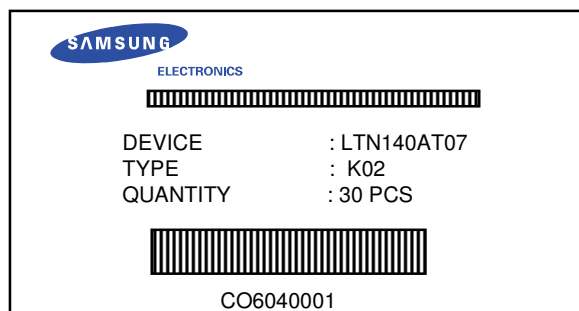

Samsung Secret

10. GENERAL PRECAUTIONS

Approval

1. Handling

- (a) When the module is assembled, It should be attached to the system firmly using every mounting holes. Be careful not to twist and bend the modules.
- (b) Refrain from strong mechanical shock and / or any force to the module. In addition to damage, this may cause improper operation or damage to the module and CCFT back-light.
- (c) Note that polarizers are very fragile and could be easily damaged. Do not press or scratch the surface harder than a HB pencil lead.
- (d) Wipe off water droplets or oil immediately. If you leave the droplets for a long time, Staining and discoloration may occur.
- (e) If the surface of the polarizer is dirty, clean it using some absorbent cotton or soft cloth.
- (f) The desirable cleaners are water, IPA (Isoprophyl Alcohol) or Hexane. Do not use Ketone type materials(ex. Acetone), Ethyl alcohol, Toluene, Ethyl acid or Methyl chloride. It might permanent damage to the polarizer due to chemical reaction.
- (g) If the liquid crystal material leaks from the panel, it should be kept away from the eyes or mouth. In case of contact with hands, legs or clothes, it must be washed away thoroughly with soap.
- (h) Protect the module from static, it may cause damage to the C-MOS Gate Array IC.
- (i) Use fingerstalls with soft gloves in order to keep display clean during the incoming inspection and assembly process.
- (j) Do not disassemble the module.
- (k) Do not pull or fold the lamp wire.
- (l) Do not adjust the variable resistor which is located on the back side.
- (m) Protection film for polarizer on the module shall be slowly peeled off just before use so that the electrostatic charge can be minimized.
- (n) Pins of I/F connector shall not be touched directly with bare hands.

Samsung Secret

Doc.No.	LTN140AT07-K02	Rev.No	04-A01-G-091111	Page	26 / 30
----------------	----------------	---------------	-----------------	-------------	---------

Approval

2. STORAGE

- (a) Do not leave the module in high temperature, and high humidity for a long time. It is highly recommended to store the module with temperature from 0 to 35 °C and relative humidity of less than 70%.
- (b) Do not store the TFT-LCD module in direct sunlight.
- (c) The module shall be stored in a dark place. It is prohibited to apply sunlight or fluorescent light during the store.

3. OPERATION

- (a) Do not connect,disconnect the module in the " Power On" condition.
- (b) Power supply should always be turned on/off by following item 6.3 " Power on/off sequence " .
- (c) Module has high frequency circuits. Sufficient suppression to the electromagnetic interference shall be done by system manufacturers. Grounding and shielding methods may be important to minimize the interference.
- (d) The cable between the back-light connector and its inverter power supply shall be a minimized length and be connected directly . The longer cable between the back-light and the inverter may cause lower luminance of lamp(CCFT) and may require higher startup voltage (Vs).
- (e) The standard limited warranty is only applicable when the module is used for general notebook applications. If used for purposes other than as specified, SEC is not to be held reliable for the defective operations. It is strongly recommended to contact SEC to find out fitness for a particular purpose.

4. OTHERS

- (a) Ultra-violet ray filter is necessary for outdoor operation.
- (b) Avoid condensation of water. It may result in improper operation or disconnection of electrode.
- (c) Do not exceed the absolute maximum rating value. (the supply voltage variation, input voltage variation, variation in part contents and environmental temperature, so on) Otherwise the module may be damaged.
- (d) If the module displays the same pattern continuously for a long period of time,it can be the situation when the image "sticks" to the screen.
- (e) This module has its circuitry PCB's on the rear side and should be handled carefully in order not to be stressed.

Samsung Secret

Doc.No.	LTN140AT07-K02	Rev.No	04-A01-G-091111	Page	27 / 30
---------	----------------	--------	-----------------	------	---------

11. EDID

Approval

Address (HEX)	FUNCTION	Value	BIN	DEC	ASCII or Data	Notes
		HEX				
00	Header	00	00000000	0		EDID Header
01		FF	11111111	255		
02		FF	11111111	255		
03		FF	11111111	255		
04		FF	11111111	255		
05		FF	11111111	255		
06		FF	11111111	255		
07		00	00000000	0		
08	ID Manufacturer Name	30	00110000	48	L E N	3 character ID
09		AE	10101110	174		"LEN" as an end-customer
0A	ID Product Code	A0	10100000	160		#HD LED
0B		40	01000000	64		
0C	32-bit serial no.	00	00000000	0		
0D		00	00000000	0		
0E		00	00000000	0		
0F		00	00000000	0		
10	Week of manufacture	00	00000000	0		
11	Year of manufacture	13	00010011	19	2009	2009
12	EDID Structure Ver.	01	00000001	1	1	EDID Ver. 1.0
13	EDID revision #	03	00000011	3	3	EDID Rev. 3
14	Video input definition	80	10000000	128		
15	Max H image size	1F	00011111	31	31	31 cm(approx)
16	Max V image size	11	00010001	17	17	17 cm(approx)
17	Display Gamma	78	01111000	120	2.2	Gamma 2.2
18	Feature support	EA	11101010	234		
19	Red/green low bits	87	10000111	135		10000111
1A	Blue/white low bits	F5	11110101	245		11111110
1B	Red x high bits	94	10010100	148	0.580	Red x 0.580= 10010100
1C	Red y	57	01010111	87	0.340	Red y 0.340= 01010111
1D	Green x	4F	01001111	79	0.310	Green x 0.310= 01001111
1E	Green y	8C	10001100	140	0.550	Green y 0.550= 10001100
1F	Blue x	27	00100111	39	0.155	Blue x 0.155= 00100111
20	Blue y	27	00100111	39	0.155	Blue y 0.155= 00100111
21	White x	50	01010000	80	0.313	White x 0.313= 01010000
22	White y	54	01010100	84	0.329	White y 0.329= 01010100
23	Established timing 1	00	00000000	0		
24	Established timing 2	00	00000000	0		
25	Established timing 3	00	00000000	0		

Samsung Secret

Doc.No.

LTN140AT07-K02

Rev.No

04-A01-G-091111

Page

28 / 30

11. EDID

Approval

26	Standard timing #1	01	00000001	1		not used
27		01	00000001	1		
28	Standard timing #2	01	00000001	1		not used
29		01	00000001	1		
2A	Standard timing #3	01	00000001	1		not used
2B		01	00000001	1		
2C	Standard timing #4	01	00000001	1		not used
2D		01	00000001	1		
2E	70	01	00000001	1		not used
2F		01	00000001	1		
30	Standard timing #6	01	00000001	1		not used
31		01	00000001	1		
32	Standard timing #7	01	00000001	1		not used
33		01	00000001	1		
34	Standard timing #8	01	00000001	1		not used
35		01	00000001	1		
36	Detailed timing/monitor descriptor #1	41	01000001	65	72.33	Main clock= 72.33 MHz (@60Hz)
37		1C	00011100	28		
38		56	01010110	86	1366	Hor active=683*2 pixels
39		A0	10100000	160	160	Hor blanking=160pixels
3A		50	01010000	80		4bit : 4bit
3B		00	00000000	0	768	Vertical active=768 lines
3C		16	00010110	22	22	Vertical blanking=22 lines
3D		30	00110000	48		4bit : 4bit
3E		30	00110000	48	48	Hor sync. Offset=48 pixels
3F		20	00100000	32	32	H sync. Width=32 pixels
40		25	00100101	37	2	V sync. Offset=2 lines
					5	V sync. Width=5 lines
41		00	00000000	0		2bit : 2bit :2bit :2bit
42		35	00110101	53	309	H image size= 309 mm(approx)
43		AE	10101110	174	174	V image size = 174 mm(approx)
44		10	00010000	16		
45	00	00000000	0		No Horizontal Border	
46	00	00000000	0		No Vertical Border	
47	19	00011001	25			
48	Detailed timing/monitor descriptor #2	CA	11001010	202	58.34	Main clock= 58.34 MHz (@60Hz)
49		16	00010110	22		
4A		56	01010110	86	1366	Hor active=683*2 pixels
4B		6F	01101111	111	111	Hor blanking=111pixels
4C		50	01010000	80		4bit : 4bit
4D		00	00000000	0	768	Vertical active=768 lines
4E		16	00010110	22	22	Vertical blanking=22 lines
4F		30	00110000	48		4bit : 4bit
50		30	00110000	48	48	Hor sync. Offset=48 pixels
51		20	00100000	32	32	H sync. Width=32 pixels
52		25	00100101	37	2	V sync. Offset=2 lines
					5	V sync. Width=5 lines
53		00	00000000	0		2bit : 2bit :2bit :2bit
54		35	00110101	53	309	H image size= 309 mm(approx)
55		AE	10101110	174	174	V image size = 174 mm(approx)
56		10	00010000	16		
57	00	00000000	0		No Horizontal Border	
58	00	00000000	0		No Vertical Border	
59	19	00011001	25			

Samsung Secret

11. EDID

Approval

5A	descriptor #3	00	00000000	0		
5B		00	00000000	0		
5C		00	00000000	0		Manufacturer Specified (Timing)
5D		0F	00001111	15		
5E		00	00000000	0		
5F		8C	10001100	140		(Horizontal active pixel #)-31
60		09	00001010	9		Image Aspect Ratio(16:9)
61		32	00110010	50		Low Refresh Rate #1(50Hz)
62		8C	10001100	140		(Horizontal active pixel #)-31
63		09	00001010	9		Image Aspect Ratio(16:9)
64		28	00101000	40		Low Refresh Rate #1(40Hz)
65		16	00010110	22		Brightness(1/10nit)
66		09	00001001	9		Feature flag(TN/LEDmode)
67		00	00000000	0		
68		4C	01001100	76		
69		A3	10100011	163		supplier ID "SEC"
6A	41	01000001	65	[A]	Product code "AT"	
6B	54	01010100	84	[T]	(Hex, LSB first)	
6C	Detailed timing/monitor descriptor #4	00	00000000	0		
6D		00	00000000	0		
6E		00	00000000	0		Monitor Name Tag (ASCII)
6F		FE	11111110	254		
70		00	00000000	0		
71		4C	01001100	76	[L]	
72		54	01010100	84	[T]	
73		4E	01001110	78	[N]	
74		31	00110001	49	[1]	
75		34	00110100	52	[4]	
76		30	00110000	48	[0]	
77		41	01000001	65	[A]	
78		54	01010100	84	[T]	
79		30	00110000	48	[0]	
7A		37	00110111	55	[7]	
7B		4B	01001011	75	[K]	
7C	30	00110000	48	[0]		
7D	32	00110010	50	[2]		
7E	Extension Flag	00	00000000	0		
7F	Checksum	55	01010101	85		

Samsung Secret

Doc.No.

LTN140AT07-K02

Rev.No

04-A01-G-091111

Page

30 / 30