

**SAMSUNG**

ELECTRONICS

Approval



TO : SONY  
 DATE : Jul. 6, 2009.

**SAMSUNG TFT-LCD****MODEL NO. : LTN140AT08-S01**

NOTE : Extension code [ -S ]  
 → LTN140AT08-S01  
 Surface type [ **Glare** ]

Any Modification of Spec is not allowed without SEC' permission

APPROVED BY :

*J. H. Oh*

PREPARED BY :

*John Lee*

**Application engineering part, TCS Team**  
**Samsung Electronics Co., Ltd.**

**Samsung Secret**

|         |                |        |                 |      |        |
|---------|----------------|--------|-----------------|------|--------|
| Doc.No. | LTN140AT08-S01 | Rev.No | 04-A00-G-090706 | Page | 1 / 27 |
|---------|----------------|--------|-----------------|------|--------|

Approval

**CONTENTS**

|   |              |
|---|--------------|
| Revision History  | ----- ( 3 )  |
| General Description   | ----- ( 4 )  |
| 1. Absolute Maximum Ratings   | ----- ( 5 )  |
| 1.1 Absolute Ratings of environment                                   |              |
| 1.2 Electrical Absolute Ratings                                       |              |
| 2. Optical Characteristics  | ----- ( 7 )  |
| 3. Electrical Characteristics   | ----- ( 10 ) |
| 3.1 TFT LCD Module  |              |
| 3.2 Backlight Unit  |              |
| 3.3 LED Driver  |              |
| 4. Block Diagram  | ----- ( 13 ) |
| 4.1 TFT LCD Module  |              |
| 4.2 LED Placement Structure   |              |
| 5. Input Terminal Pin Assignment                                      | ----- ( 14 ) |
| 5.1 Input Signal & Power  |              |
| 5.2 LVDS Interface  |              |
| 5.3 Timing Diagrams of LVDS For Transmitting                          |              |
| 5.4 Input Signals, Basic Display Colors and Gray Scale of Each Color. |              |
| 5.5 Pixel format  |              |
| 6. Interface Timing   |              |
| 6.1 Timing Parameters   | ----- ( 19 ) |
| 6.2 Timing Diagrams of interface Signal                               |              |
| 6.3 Power ON/OFF Sequence   |              |
| 7. Outline Dimension  | ----- ( 21 ) |
| 8. Packing  | ----- ( 23 ) |
| 9. Markings & Others  | ----- ( 24 ) |
| 10. General Precaution  | ----- ( 26 ) |

**Samsung Secret**

## REVISION HISTORY

Approval

| Date   | Revision No. | Page | Summary   |
|--|--------------|------|---|
| Apr. 1, 2009   | P00          | All  | The Preliminary specification of LTN140AT08-S01 was issued first. |
| Apr. 17, 2009  | P01          | P.10 | Main Frequency was updated. (Min. & Max.)                         |
|  |              | P.19 | Timing parameter was updated. (Min. & Max.)                       |
| July. 6. 2009  | A00          | All  | The Approval specification of LTN140AT08-S01 was issued first.    |
| <div style="position: absolute; top: 50%; left: 50%; transform: translate(-50%, -50%); opacity: 0.1; font-size: 4em; pointer-events: none;">www.panelook.com</div> |              |      |   |

**Samsung Secret**

|                |                |               |                 |             |        |
|----------------|----------------|---------------|-----------------|-------------|--------|
| <b>Doc.No.</b> | LTN140AT08-S01 | <b>Rev.No</b> | 04-A00-G-090706 | <b>Page</b> | 3 / 27 |
|----------------|----------------|---------------|-----------------|-------------|--------|

Approval

## GENERAL DESCRIPTION

### DESCRIPTION

LTN140AT08-S01 is a color active matrix TFT (Thin Film Transistor) liquid crystal display (LCD) that uses amorphous silicon TFT as switching devices. This model is composed of a TFT LCD panel, a driver circuit and a backlight system. The resolution of a 14.0" contains 1366 x 768 pixels and can display up to 262,144 colors. 6 O'clock direction is the Optimum viewing angle.

### FEATURES

- High contrast ratio, high aperture structure
- 1366 x 768 pixels resolution
- Color Gamut Typ. 45%
- Fast Response Time
- Low power consumption
- LED BLU Structure
- DE (Data enable) only mode.
- 3.3V LVDS Interface
- On board EDID chip
- RoHS Compliance

### APPLICATIONS

- Notebook PC
- If the usage of this product is not for PC application, but for others, please contact SEC

## GENERAL INFORMATION

| Item              | Specification                            | Unit  | Note   |
|-------------------|--|-------|--------|
| Display area      | 309.399(H) X 173.952(V) (14.0" diagonal) | mm    |        |
| Driver element    | a-si TFT active matrix                   |       |        |
| Display colors    | 262,144                                  |       |        |
| Number of pixel   | 1366 x 768                               | pixel | 16 : 9 |
| Pixel arrangement | RGB vertical stripe                      |       |        |
| Pixel pitch       | 0.2265(H) x 0.2265(V)                    | mm    |        |
| Display Mode      | Normally white                           |       |        |
| Surface treatment | Haze 0, Hard-Coating 3H                  |       |        |

Samsung Secret

## Mechanical Information

Approval

| Item        |                | Min.  | Typ.  | Max.  | Unit | Note          |
|-------------|----------------|-------|-------|-------|------|---------------|
| Module size | Horizontal (H) | 319.9 | 320.4 | 320.9 | mm   |               |
|             | Vertical (V)   | 186.6 | 187.1 | 187.6 | mm   | w/o converter |
|             |                | -     | 198.6 | -     |      |               |
|             | Depth (D)      | -     | -     | 3.6   | mm   | (1)           |
| Weight      |                | -     | -     | 330   | g    |               |

Note (1) Measurement condition of outline dimension

- . Equipment : Vernier Calipers
- . Push Force : 500g · f (minimum)

## 1. ABSOLUTE MAXIMUM RATINGS

### 1.1 ENVIRONMENTAL ABSOLUTE RATINGS

| Item  | Symbol | Min. | Max. | Unit | Note    |
|---|--------|------|------|------|---------|
| Storage temperate                                     | TSTG   | -20  | 60   | °C   | (1)     |
| Operating temperate<br>(Temperature of glass surface) | TOPR   | 0    | 50   | °C   | (1)     |
| Shock ( non-operating )                               | Snop   | -    | 240  | G    | (2),(4) |
| Vibration (non-operating)                             | Vnop   | -    | 2.41 | G    | (3),(4) |

Note (1) Temperature and relative humidity range are shown in the figure below.

95 % RH Max. ( $40\text{ °C} \geq T_a$ )

Maximum wet - bulb temperature at  $39\text{ °C}$  or less. ( $T_a > 40\text{ °C}$ ) No condensation

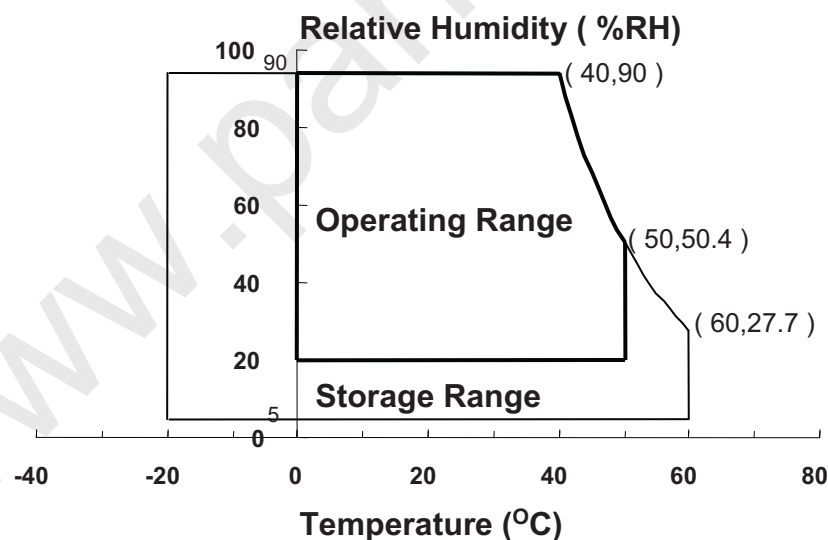

(2) 2ms, half sine wave, one time for  $\pm X$ ,  $\pm Y$ ,  $\pm Z$ .

(3) 5 - 500 Hz, random vibration, 30min for X, Y, Z.

(4) At testing Vibration and Shock, the fixture in holding the Module to be tested have to be hard and rigid enough so that the Module would not be twisted or bent by the fixture.

**Samsung Secret**

Approval

## 1.2 ELECTRICAL ABSOLUTE RATINGS

## (1) TFT LCD MODULE

 $V_{DD} = 3.3V, V_{SS} = GND = 0V$ 

| Item                 | Symbol   | Min.           | Max.           | Unit | Note |
|----------------------|----------|----------------|----------------|------|------|
| Power Supply Voltage | $V_{DD}$ | $V_{DD} - 0.3$ | $V_{DD} + 0.3$ | V    | (1)  |
| Logic Input Voltage  | $V_{DD}$ | $V_{DD} - 0.3$ | $V_{DD} + 0.3$ | V    | (1)  |

Note (1) Within  $T_a$  ( $25 \pm 2 \text{ }^\circ\text{C}$ )

Samsung Secret

Doc.No.

LTN140AT08-S01

Rev.No

04-A00-G-090706

Page

6 / 27

### 3. ELECTRICAL CHARACTERISTICS

Approval

#### 3.1 TFT LCD MODULE

Ta= 25 ± 2°C

| Item   | Symbol            | Min.            | Typ. | Max.       | Unit       | Note       |                         |
|--|-------------------|-----------------|------|------------|------------|------------|-------------------------|
| Voltage of Power Supply                                | V <sub>DD</sub>   | 3.0             | 3.3  | 3.6        | V          |            |                         |
| Differential Input Voltage for LVDS Receiver Threshold | High              | V <sub>IH</sub> | -    | -          | 100        | mV         | V <sub>CM</sub> = +1.2V |
|  | Low               | V <sub>IL</sub> | 100  | -          | -          | mV         |                         |
| Vsync Frequency  | f <sub>v</sub>    | -               | 60   | -          | Hz         |            |                         |
| Hsync Frequency  | f <sub>H</sub>    | -               | 47.4 | -          | KHz        | Vsync=60Hz |                         |
| Main Frequency   | f <sub>DCLK</sub> | 67.4            | 72.3 | 105.8      | MHz        |            |                         |
| Spread Spectrum  | Modulation rate   | F <sub>mr</sub> | -2   | -          | +2         | %          | Center Spreading        |
|  | Modulation freq.  | F <sub>mf</sub> | 30   | -          | 300        | Khz        |                         |
| Rush Current   | I <sub>RUSH</sub> | -               | -    | 1.5        | A          | (4)        |                         |
| Current of Power Supply                                | White             | I <sub>DD</sub> | -    | <b>340</b> | -          | mA         | (2),(3)*a               |
|  | Mosaic            | I <sub>DD</sub> | -    | <b>360</b> | -          | mA         | (2),(3)*b               |
|  | V. Stripe         | I <sub>DD</sub> | -    | <b>380</b> | <b>500</b> | mA         | (2),(3)*c               |

Note (1) Display data pins and timing signal pins should be connected.( GND = 0V )

(2) f<sub>v</sub> = 60Hz, f<sub>DCLK</sub> = 72.3MHz, V<sub>DD</sub> = 3.3V , DC Current.

(3) Power dissipation pattern

\*a) White Pattern

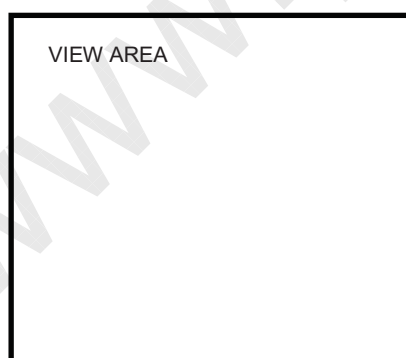

\*b) Mosaic Pattern

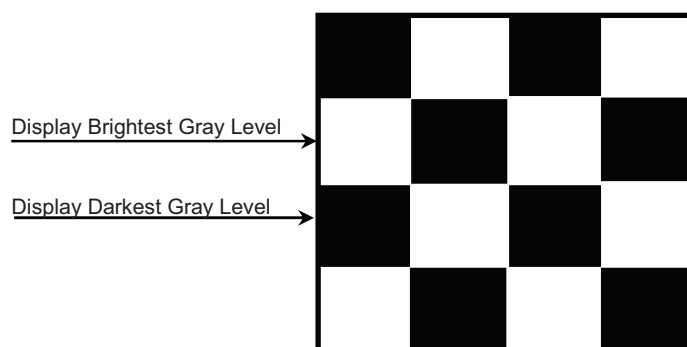

**Samsung Secret**

Doc.No.

LTN140AT08-S01

Rev.No

04-A00-G-090706

Page

10 / 27

Approval

\*c) 1dot Vertical stripe pattern

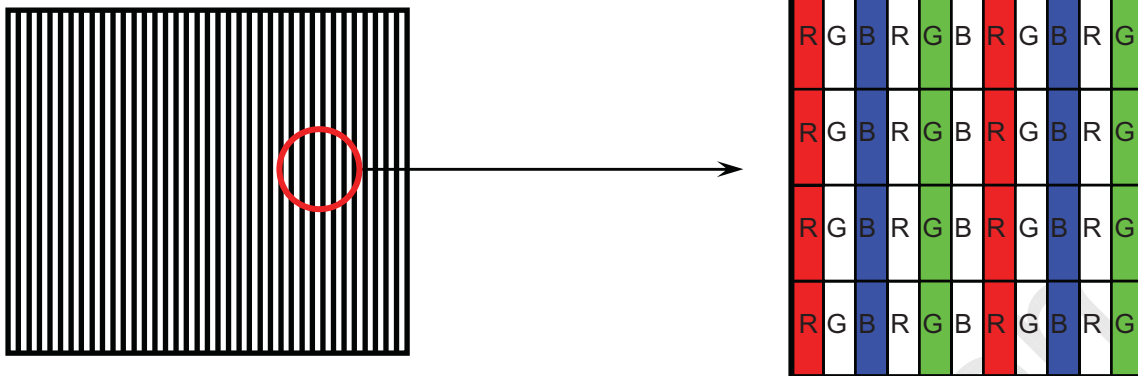

4) Rush current measurement condition

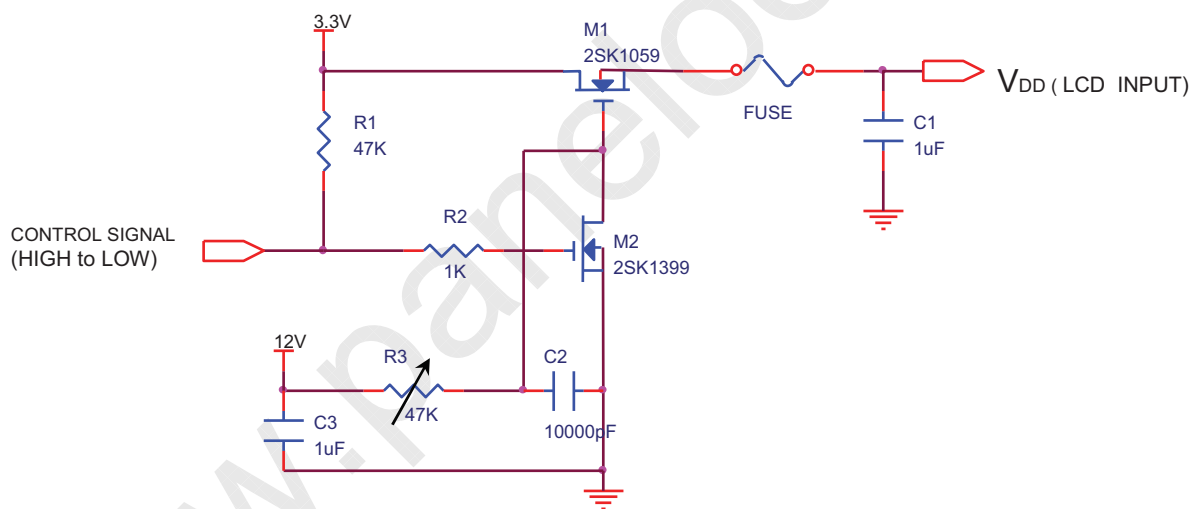

$V_{DD}$  rising time is 470us

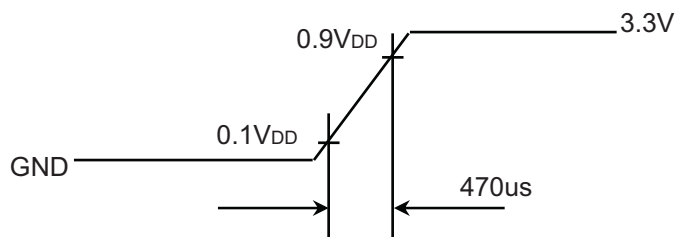

**Samsung Secret**

|         |                |        |                 |      |         |
|---------|----------------|--------|-----------------|------|---------|
| Doc.No. | LTN140AT08-S01 | Rev.No | 04-A00-G-090706 | Page | 11 / 27 |
|---------|----------------|--------|-----------------|------|---------|



Approval

## 3.2 BACK-LIGHT UNIT

Ta= 25 ± 2 °C

| Item                | Symbol | Min.   | Typ. | Max. | Unit | Note   |
|---------------------|--------|--------|------|------|------|--|
| LED Forward Current | IF     | -      | 20   | -    | mA   |  |
| LED Forward Voltage | VF     | -      | 3.2  | 3.4  | V    |  |
| LED Array Voltage   | VP     | -      | 19.2 | 20.4 | V    | VF X 6 LEDs                                  |
| Power Consumption   | P      | -      | 3.0  | -    | W    | (IF X VF X 42LEDs)<br>(6 serial, 7 parallel) |
| Operating Life time | Hr     | 10,000 |      |      | Hr   | (1)  |

Note (1) Life time (Hr) of LEDs can be defined as the time in which it continues to operate under the condition Ta= 25 ± 2 °C and IF = 19 mA until below event occurs.

- When the brightness becomes 50% or lower than the original.

## 3.3 LED Driver

- On board LED Driver (Manufacturer : SEC)

Ta= 25 ± 2 °C

| Item  | Symbol            | Min. | Typ. | Max. | Unit             | Note  |
|---|-------------------|------|------|------|------------------|---|
| Input Voltage                                 | V <sub>in</sub>   | 7    | 12   | 21   | V <sub>LED</sub> |   |
| Input Current                                 | I                 | -    | 280  | -    | mA               | RMS   |
| Enable Control Level                          | V                 | 0    | -    | 3.3  | V                | ON Level : 2V~3.3V<br>OFF Level : 0V ~ 0.5V     |
| External PWM Dimming Control Frequency (BLIM) | F <sub>BLIM</sub> | 0.2  | -    | 1    | kHz              | High Level : 1.5V~3.3V<br>Low Level : 0V ~ 0.1V |
| PWM Control Duty Ratio                        | D                 | 5    | -    | 100  | %                | (1)   |

Note (1) The operation of LED Driver below minimum dimming ratio may cause flicking or reliability issue.

Samsung Secret

Approval

## 4. BLOCK DIAGRAM

### 4.1 TFT LCD Module

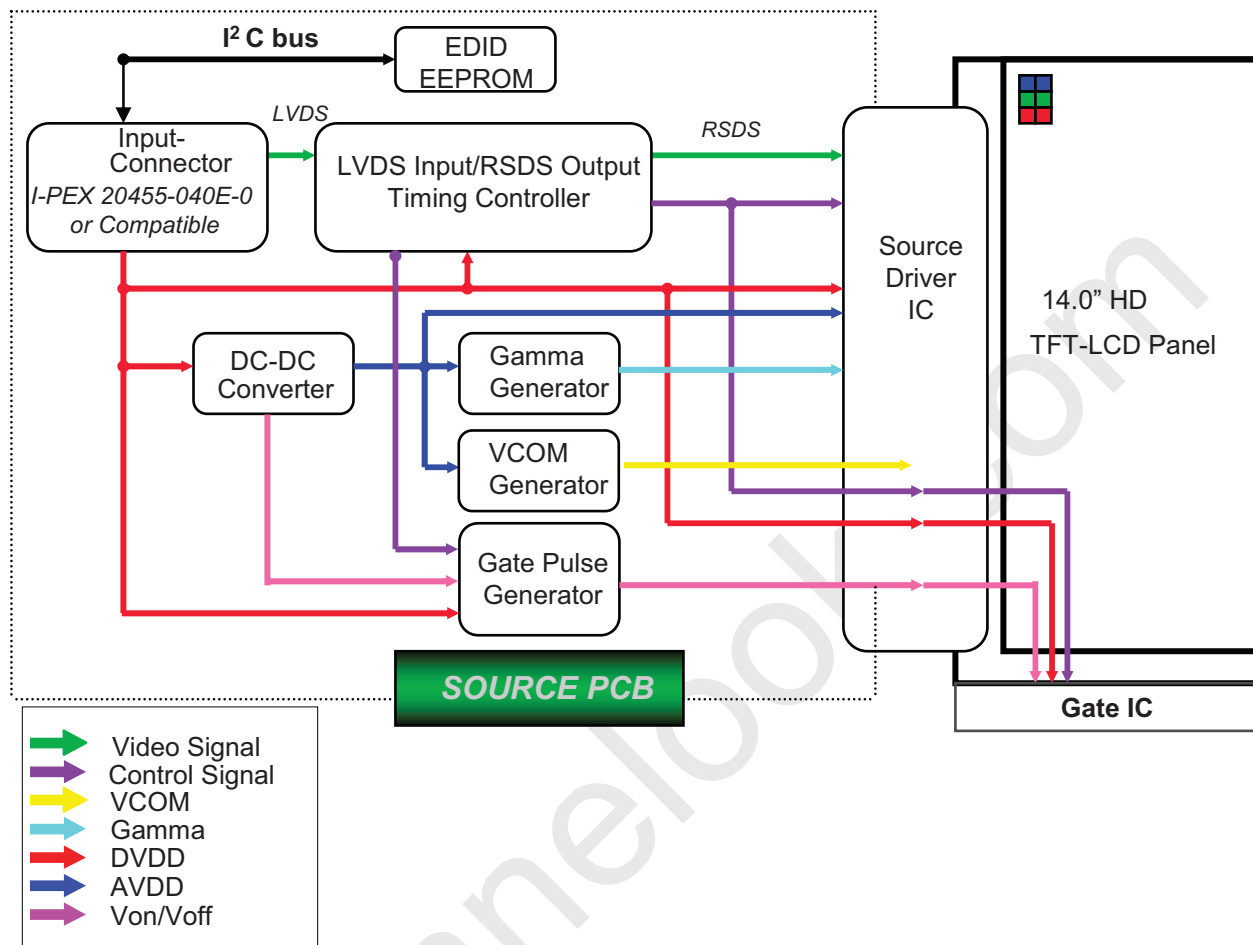

**Samsung Secret**

|                |                |               |                 |             |         |
|----------------|----------------|---------------|-----------------|-------------|---------|
| <b>Doc.No.</b> | LTN140AT08-S01 | <b>Rev.No</b> | 04-A00-G-090706 | <b>Page</b> | 13 / 27 |
|----------------|----------------|---------------|-----------------|-------------|---------|

Approval

## 5. INPUT TERMINAL PIN ASSIGNMENT

### 5.1. Input Signal & Power (LVDS, Connector : I-PEX 20455-040E-0 or equivalent )

| Pin     | Symbol    | Function   |
|---------|-----------|--|
| 1       | NC        | No Connection  |
| 2~3     | VDD       | Power Supply, 3.3V (typical)                             |
| 4       | VEDID     | EDID 3.3V power  |
| 5       | NC        | No Connection  |
| 6       | CLK       | EDID clock   |
| 7       | DATA      | EDID data  |
| 8       | RIN0-     | - LVDS differential data input (R0-R5, G0)               |
| 9       | RIN0+     | + LVDS differential data input (R0-R5, G0)               |
| 10      | GND       | Ground   |
| 11      | RIN1-     | - LVDS differential data input (G1-G5, B0-B1)            |
| 12      | RIN1+     | + LVDS differential data input (G1-G5, B0-B1)            |
| 13      | GND       | Ground   |
| 14      | RIN2-     | - LVDS differential data input (B2-B5,HS,VS, DE)         |
| 15      | RIN2+     | + LVDS differential data input (B2-B5,HS,VS, DE)         |
| 16      | GND       | Ground   |
| 17      | CLK-      | - LVDS differential clock input                          |
| 18      | CLK+      | + LVDS differential clock input                          |
| 19      | GND       | Ground   |
| 20 ~ 21 | NC        | No Connection  |
| 22      | GND       | Ground   |
| 23 ~ 24 | NC        | No Connection  |
| 25      | GND       | Ground   |
| 26 ~ 27 | NC        | No Connection  |
| 28      | GND       | Ground   |
| 29 ~ 30 | NC        | No Connection  |
| 31 ~ 33 | VLED_GND  | LED Ground   |
| 34      | NC        | No Connection  |
| 35      | BLIM      | PWM for luminance control ( 200 ~ 1KHz, 3.3V, 5 ~ 100% ) |
| 36      | BL_Enable | BL On/Off ( On : 2.0 ~ 3.3V, Off : 0 ~0.5V )             |
| 37      | NC        | No Connection  |
| 38~40   | VLED      | LED Power Supply (7V-21V)                                |

**Samsung Secret**

Doc.No.

LTN140AT08-S01

Rev.No

04-A00-G-090706

Page

14 / 27

Approval

## 5.2 LVDS Interface : Transmitter SN75LVDS86 or Compatible

| Pin No. | Name   | RGB Signal | Pin No. | Name    | RGB Signal |
|---------|--------|------------|---------|---------|------------|
| 44      | TxIN0  | R0         | 12      | TxIN11  | G5         |
| 45      | TxIN1  | R1         | 13      | TxIN12  | B0         |
| 47      | TxIN2  | R2         | 15      | TxIN13  | B1         |
| 48      | TxIN3  | R3         | 16      | TxIN14  | B2         |
| 1       | TxIN4  | R4         | 18      | TxIN15  | B3         |
| 3       | TxIN5  | R5         | 19      | TxIN16  | B4         |
| 4       | TxIN6  | G0         | 20      | TxIN17  | B5         |
| 6       | TxIN7  | G1         | 22      | TxIN18  | Hsync      |
| 7       | TxIN8  | G2         | 23      | TxIN19  | Vsync      |
| 9       | TxIN9  | G3         | 25      | TxIN20  | DE         |
| 10      | TxIN10 | G4         | 26      | TxCLKIN | Clock      |

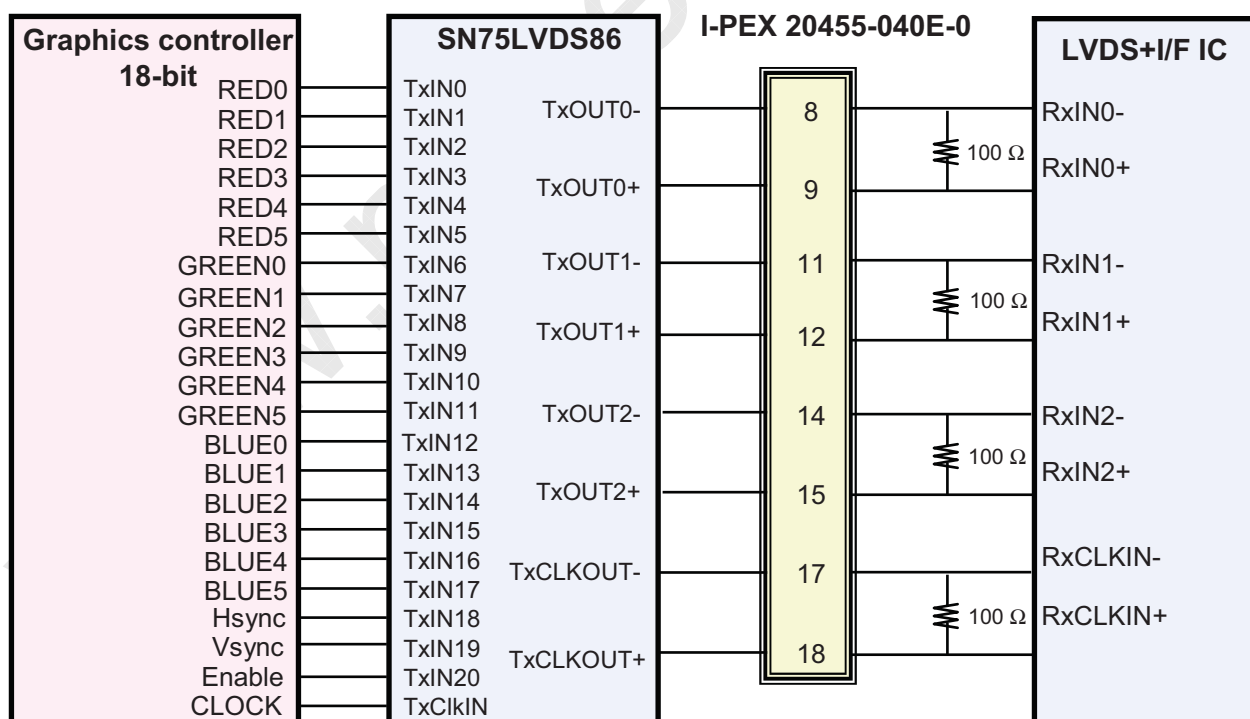
**LVDS INTERFACE**

Note : The LCD Module uses a 100ohm resistor between positive and negative lines of each receiver input.

Samsung Secret

|         |                |        |                 |      |         |
|---------|----------------|--------|-----------------|------|---------|
| Doc.No. | LTN140AT08-S01 | Rev.No | 04-A00-G-090706 | Page | 15 / 27 |
|---------|----------------|--------|-----------------|------|---------|

Approval

### 5.3 Timing Diagrams of LVDS For Transmission

LVDS Receiver : Integrated T-CON

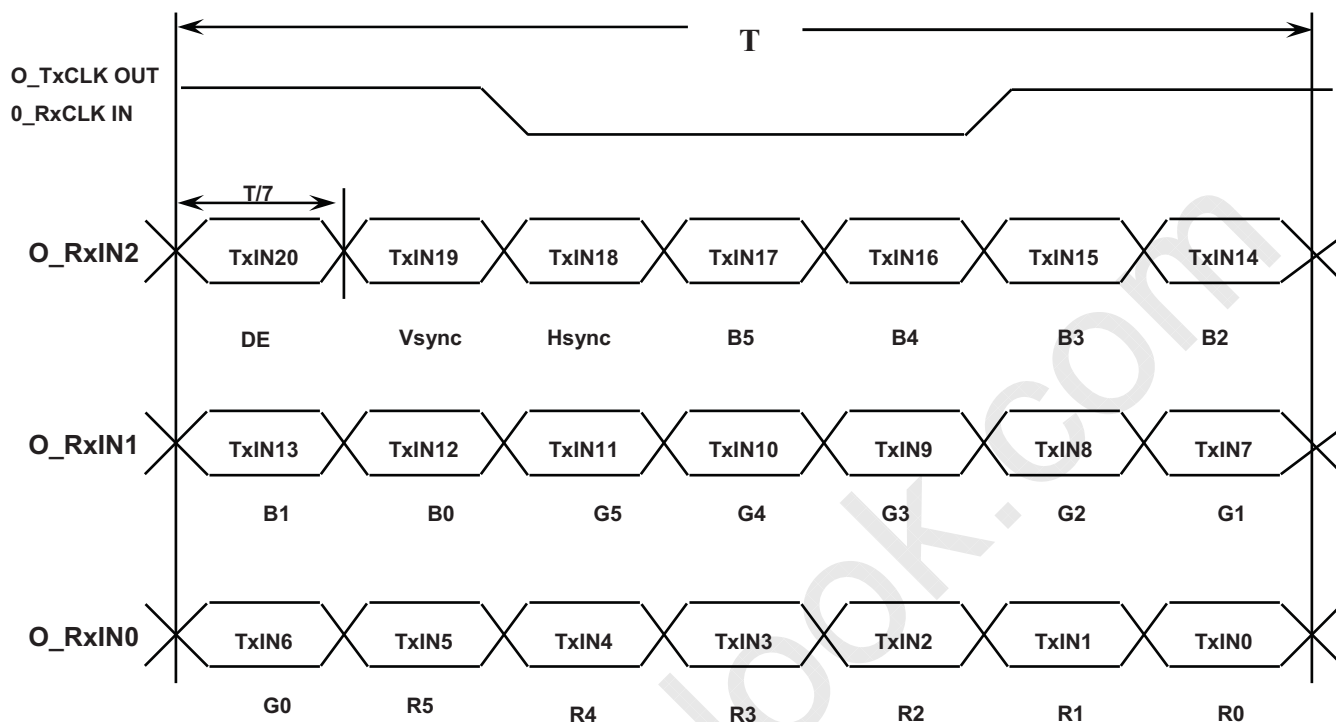

Samsung Secret

|         |                |        |                 |      |         |
|---------|----------------|--------|-----------------|------|---------|
| Doc.No. | LTN140AT08-S01 | Rev.No | 04-A00-G-090706 | Page | 16 / 27 |
|---------|----------------|--------|-----------------|------|---------|

Approval

5.4 Input Signals, Basic Display Colors and Gray Scale of Each Color

| Color               | Display | Data Signal |    |    |    |    |       |    |    |    |    |      |    |    |    |    |    | Gray Scale Level |        |
|---------------------|---------|-------------|----|----|----|----|-------|----|----|----|----|------|----|----|----|----|----|------------------|--------|
|                     |         | Red         |    |    |    |    | Green |    |    |    |    | Blue |    |    |    |    |    |                  |        |
|                     |         | R0          | R1 | R2 | R3 | R4 | R5    | G0 | G1 | G2 | G3 | G4   | G5 | B0 | B1 | B2 | B3 |                  | 45     |
| Basic Colors        | Black   | 0           | 0  | 0  | 0  | 0  | 0     | 0  | 0  | 0  | 0  | 0    | 0  | 0  | 0  | 0  | 0  | 0                | -      |
|                     | Blue    | 0           | 0  | 0  | 0  | 0  | 0     | 0  | 0  | 0  | 0  | 0    | 0  | 1  | 1  | 1  | 1  | 1                | -      |
|                     | Green   | 0           | 0  | 0  | 0  | 0  | 0     | 1  | 1  | 1  | 1  | 1    | 1  | 0  | 0  | 0  | 0  | 0                | -      |
|                     | Cyan    | 0           | 0  | 0  | 0  | 0  | 0     | 1  | 1  | 1  | 1  | 1    | 1  | 1  | 1  | 1  | 1  | 1                | -      |
|                     | Red     | 1           | 1  | 1  | 1  | 1  | 1     | 0  | 0  | 0  | 0  | 0    | 0  | 0  | 0  | 0  | 0  | 0                | -      |
|                     | Magenta | 1           | 1  | 1  | 1  | 1  | 1     | 0  | 0  | 0  | 0  | 0    | 0  | 1  | 1  | 1  | 1  | 1                | -      |
|                     | Yellow  | 1           | 1  | 1  | 1  | 1  | 1     | 1  | 1  | 1  | 1  | 1    | 1  | 0  | 0  | 0  | 0  | 0                | -      |
|                     | White   | 1           | 1  | 1  | 1  | 1  | 1     | 1  | 1  | 1  | 1  | 1    | 1  | 1  | 1  | 1  | 1  | 1                | -      |
| Gray Scale Of Red   | Black   | 0           | 0  | 0  | 0  | 0  | 0     | 0  | 0  | 0  | 0  | 0    | 0  | 0  | 0  | 0  | 0  | 0                | R0     |
|                     | Dark    | 1           | 0  | 0  | 0  | 0  | 0     | 0  | 0  | 0  | 0  | 0    | 0  | 0  | 0  | 0  | 0  | 0                | R1     |
|                     | ↑       | 0           | 1  | 0  | 0  | 0  | 0     | 0  | 0  | 0  | 0  | 0    | 0  | 0  | 0  | 0  | 0  | 0                | R2     |
|                     | :       | :           | :  | :  | :  | :  | :     | :  | :  | :  | :  | :    | :  | :  | :  | :  | :  | :                | R3~R60 |
|                     | :       | :           | :  | :  | :  | :  | :     | :  | :  | :  | :  | :    | :  | :  | :  | :  | :  | :                |        |
|                     | ↓       | 1           | 0  | 1  | 1  | 1  | 1     | 0  | 0  | 0  | 0  | 0    | 0  | 0  | 0  | 0  | 0  | 0                | R61    |
|                     | Light   | 0           | 1  | 1  | 1  | 1  | 1     | 0  | 0  | 0  | 0  | 0    | 0  | 0  | 0  | 0  | 0  | 0                | R62    |
|                     | Red     | 1           | 1  | 1  | 1  | 1  | 1     | 0  | 0  | 0  | 0  | 0    | 0  | 0  | 0  | 0  | 0  | 0                | R63    |
| Gray Scale Of Green | Black   | 0           | 0  | 0  | 0  | 0  | 0     | 0  | 0  | 0  | 0  | 0    | 0  | 0  | 0  | 0  | 0  | 0                | G0     |
|                     | Dark    | 0           | 0  | 0  | 0  | 0  | 0     | 1  | 0  | 0  | 0  | 0    | 0  | 0  | 0  | 0  | 0  | 0                | G1     |
|                     | ↑       | 0           | 0  | 0  | 0  | 0  | 0     | 0  | 1  | 0  | 0  | 0    | 0  | 0  | 0  | 0  | 0  | 0                | G2     |
|                     | :       | :           | :  | :  | :  | :  | :     | :  | :  | :  | :  | :    | :  | :  | :  | :  | :  | :                | G3~G60 |
|                     | :       | :           | :  | :  | :  | :  | :     | :  | :  | :  | :  | :    | :  | :  | :  | :  | :  | :                |        |
|                     | ↓       | 0           | 0  | 0  | 0  | 0  | 0     | 1  | 0  | 1  | 1  | 1    | 1  | 0  | 0  | 0  | 0  | 0                | G61    |
|                     | Light   | 0           | 0  | 0  | 0  | 0  | 0     | 0  | 1  | 1  | 1  | 1    | 1  | 0  | 0  | 0  | 0  | 0                | G62    |
|                     | Green   | 0           | 0  | 0  | 0  | 0  | 0     | 1  | 1  | 1  | 1  | 1    | 1  | 0  | 0  | 0  | 0  | 0                | G63    |
| Gray Scale Of Blue  | Black   | 0           | 0  | 0  | 0  | 0  | 0     | 0  | 0  | 0  | 0  | 0    | 0  | 0  | 0  | 0  | 0  | 0                | B0     |
|                     | Dark    | 0           | 0  | 0  | 0  | 0  | 0     | 0  | 0  | 0  | 0  | 0    | 0  | 1  | 0  | 0  | 0  | 0                | B1     |
|                     | ↑       | 0           | 0  | 0  | 0  | 0  | 0     | 0  | 0  | 0  | 0  | 0    | 0  | 0  | 1  | 0  | 0  | 0                | B2     |
|                     | :       | :           | :  | :  | :  | :  | :     | :  | :  | :  | :  | :    | :  | :  | :  | :  | :  | :                | B3~B60 |
|                     | :       | :           | :  | :  | :  | :  | :     | :  | :  | :  | :  | :    | :  | :  | :  | :  | :  | :                |        |
|                     | ↓       | 0           | 0  | 0  | 0  | 0  | 0     | 0  | 0  | 0  | 0  | 0    | 0  | 1  | 0  | 1  | 1  | 1                | B61    |
|                     | Light   | 0           | 0  | 0  | 0  | 0  | 0     | 0  | 0  | 0  | 0  | 0    | 0  | 0  | 1  | 1  | 1  | 1                | B62    |
|                     | Blue    | 0           | 0  | 0  | 0  | 0  | 0     | 0  | 0  | 0  | 0  | 0    | 0  | 1  | 1  | 1  | 1  | 1                | B63    |

Note 1) Definition of gray :

Rn: Red gray, Gn: Green gray, Bn: Blue gray (n=gray level)

Note 2) Input signal: 0 =Low level voltage, 1=High level voltage

**Samsung Secret**

Approval

## 5.5 Pixel Format in the display

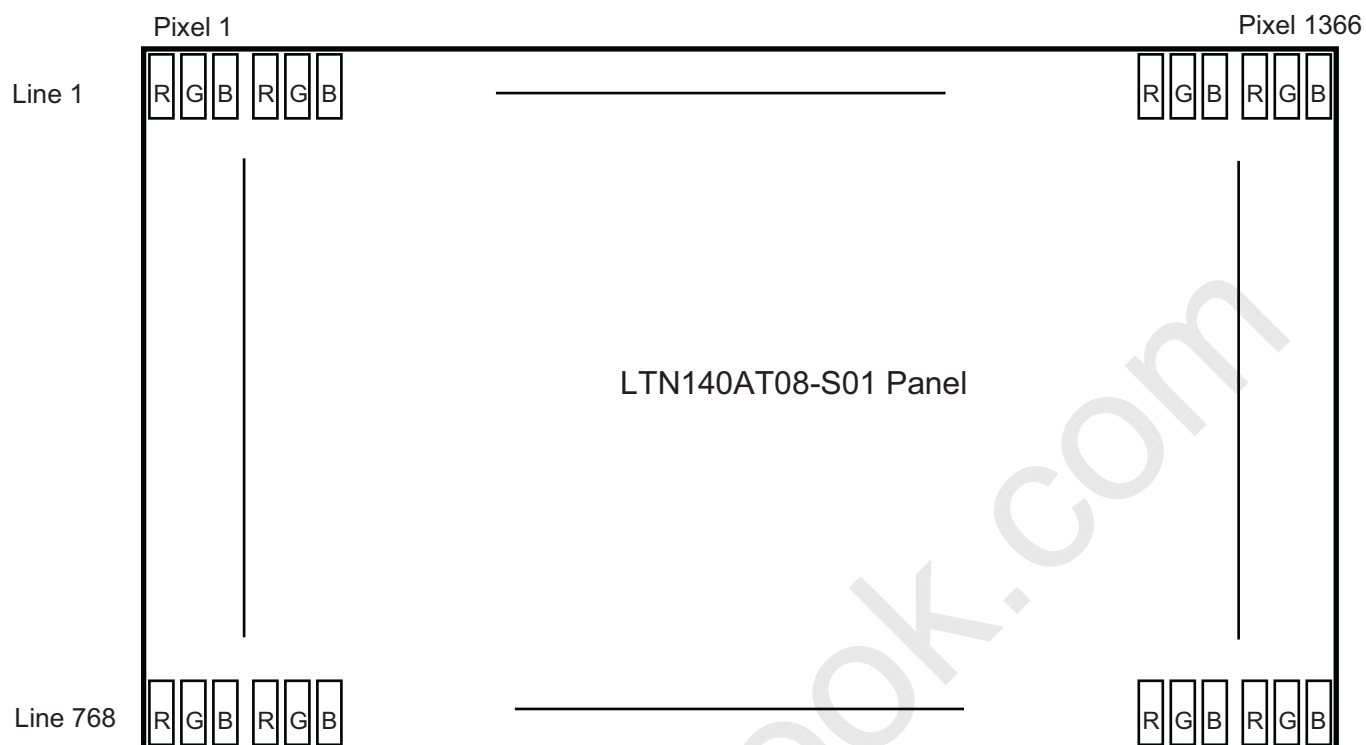

Samsung Secret

Doc.No.

LTN140AT08-S01

Rev.No

04-A00-G-090706

Page

18 / 27

Approval

## 6. INTERFACE TIMING

### 6.1 Timing Parameters

| Signal                         | Item           | Symbol | Min. | Typ. | Max. | Unit   | Note |
|--------------------------------|----------------|--------|------|------|------|--------|------|
| Frame Frequency                | Cycle          | TV     | 780  | 790  | 980  | Lines  | -    |
| Vertical Active Display Term   | Display Period | TVD    | -    | 768  | -    | Lines  | -    |
| One Line Scanning Time         | Cycle          | TH     | 1440 | 1526 | 1800 | Clocks | -    |
| Horizontal Active Display Term | Display Period | THD    | -    | 1366 | -    | Clocks | -    |

### 6.2 Timing diagrams of interface signal

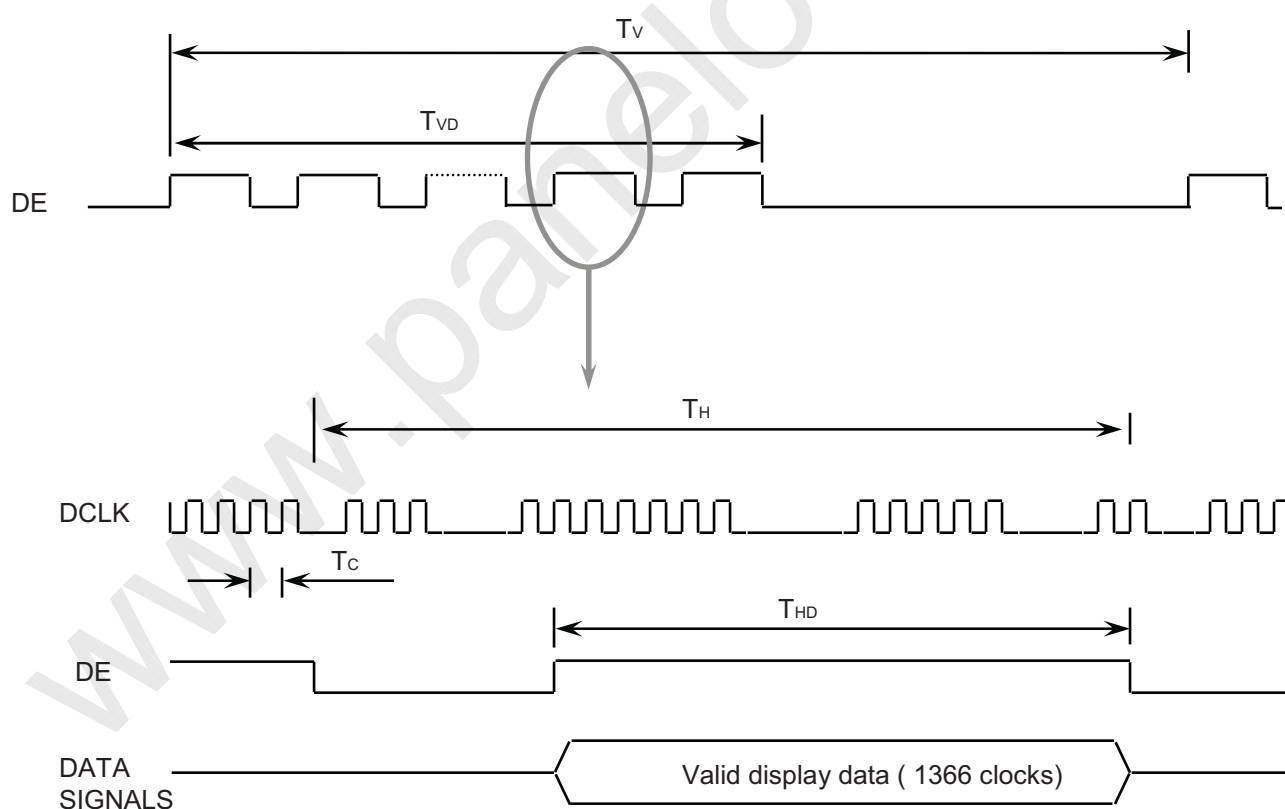

**Samsung Secret**

Doc.No.

LTN140AT08-S01

Rev.No

04-A00-G-090706

Page

19 / 27



## 6.3 Power ON/OFF Sequence

Approval

: To prevent a latch-up or DC operation of the LCD module, the power on/off sequence should be as the diagram below.

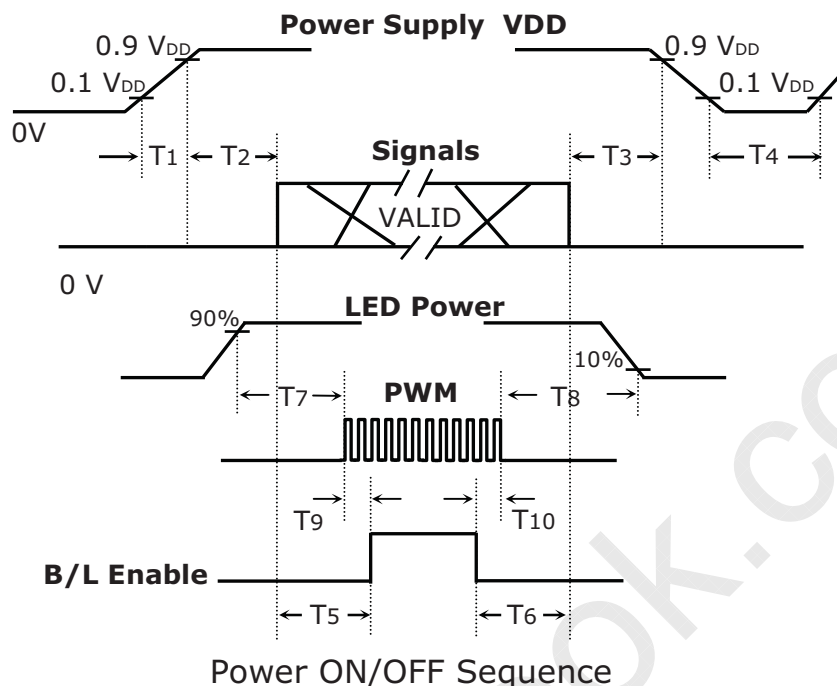

| Timing (ms)         | Remarks   |
|---------------------|---|
| $0.5 < T_1 \leq 10$ | V <sub>DD</sub> rising time from 10% to 90%                   |
| $0 < T_2 \leq 50$   | Delay from V <sub>DD</sub> to valid data at power ON          |
| $0 < T_3 \leq 50$   | Delay from valid data OFF to V <sub>DD</sub> off at power OFF |
| $500 \leq T_4$      | V <sub>DD</sub> OFF time for Windows restart                  |
| $200 \leq T_5$      | Delay from valid data to B/L enable at power ON               |
| $200 \leq T_6$      | Delay from valid data off to B/L disable at power OFF         |
| $0 < T_7$           | Delay from LED driver power ON to PWM ON                      |
| $0 < T_8$           | Delay from PWM OFF to LED driver power OFF                    |
| $10 \leq T_9$       | Delay from PWM ON to B/L Enable ON                            |
| $0 < T_{10}$        | Delay from B/L Enable Off to PWM OFF                          |

## NOTE.

- (1) The supply voltage of the external system for the module input should be the same as the definition of V<sub>DD</sub>.
- (2) In case of V<sub>DD</sub> = off level, please keep the level of input signals on the low or keep a high impedance.
- (3) T<sub>4</sub> should be measured after the module has been fully discharged between power off and on period.
- (4) Interface signal shall not be kept at high impedance when the power is on.

Samsung Secret

|         |                |        |                 |      |         |
|---------|----------------|--------|-----------------|------|---------|
| Doc.No. | LTN140AT08-S01 | Rev.No | 04-A00-G-090706 | Page | 20 / 27 |
|---------|----------------|--------|-----------------|------|---------|



### 7. MECHANICAL OUTLINE DIMENSION

Approval

[ Refer to the next page ]

www.panelook.com

**Samsung Secret**

|                |                |               |                 |             |         |
|----------------|----------------|---------------|-----------------|-------------|---------|
| <b>Doc.No.</b> | LTN140AT08-S01 | <b>Rev.No</b> | 04-A00-G-090706 | <b>Page</b> | 21 / 27 |
|----------------|----------------|---------------|-----------------|-------------|---------|

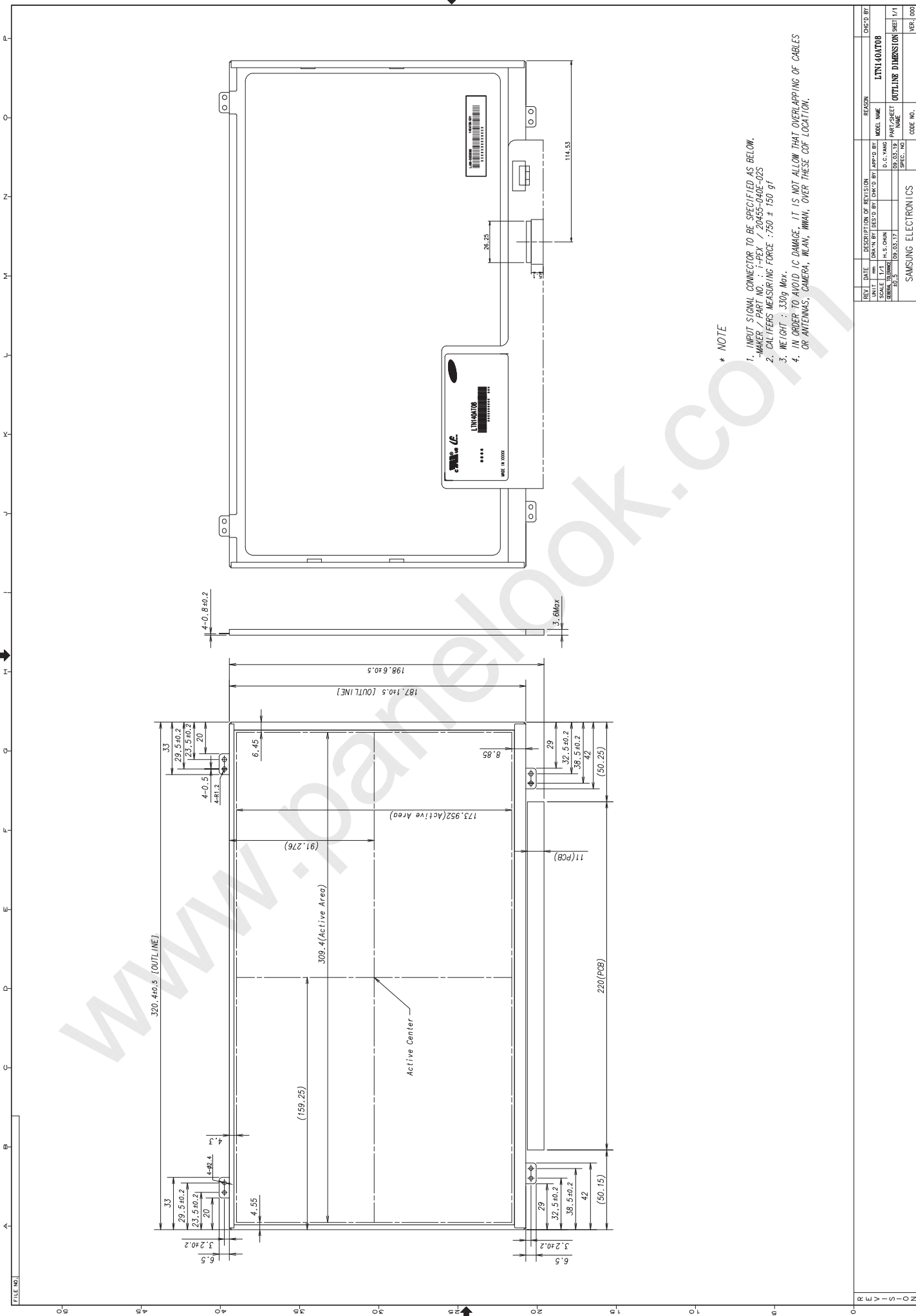

## \* NOTE

1. INPUT SIGNAL CONNECTOR TO BE SPECIFIED AS BELOW.  
-MAKER / PART NO. : i-PEX / 20455-040E-02S
2. CALIFERS MEASURING FORCE : 750 ± 150 gf
3. WEIGHT : 330g Max.
4. IN ORDER TO AVOID I.C DAMAGE, IT IS NOT ALLOW THAT OVERLAPPING OF CABLES OR ANTENNAS, CAMERA, IR-LAN, WMAN, OVER THESE CO-LOCATION.

| REV.                | DATE | DESCRIPTION OF REVISED                             | APPRO'D BY | REASON          | CHK'D BY                    |
|---------------------|------|--|------------|-----------------|-----------------------------|
| 1.0                 |      | DRW'N BY: IUS-D BY: CHD-D BY: IAP'D BY: I.D.S. YMS |            | MODEL NAME      | LTVN1401708                 |
|                     |      | SCALE 1/1  |            | PART/SHEET NAME | OUTLINE DIMENSION SHEET 1/1 |
|                     |      | GENERAL NOTE                                       |            | SPEC. NO.       |                             |
|                     |      | REV.03.17  |            | CODE NO.        |                             |
| SAMSUNG ELECTRONICS |      |  |            |                 |                             |
|                     |      |  |            |                 | VER. 000                    |

## 8. PACKING

Approval

### 1. CARTON(Internal Package)

#### (1) Packing Form

Corrugated Cardboard box and Corrupad form as shock absorber

#### (2) Packing Method



PACKING CASE

- Note*
- 1) Total Weight : Approximately 3.1 kg
  - 2) Acceptance number of piling : 4 sets
  - 3) Carton size : 428(W) \* 359(D) \* 322(H)

**Samsung Secret**

Doc.No.

LTN140AT08-S01

Rev.No

04-A00-G-090706

Page

23 / 27

Approval

(3)Packing Material

| No | Part name   | Quantity |
|----|---|----------|
| 1  | Static electric protective sack                     | 20       |
| 2  | Packing case (Inner box)<br>included shock absorber | 1 set    |
| 3  | Pictorial marking                                   | 2        |
| 4  | Carton  | 1 set    |

9. MARKINGS & OTHERS

A nameplate bearing followed by is affixed to a shipped product at the specified location on each product.

(1)Parts number : LTN140AT08

(2)Revision code : 3 letters

(3)Lot number : X X X X XXX XX X S01

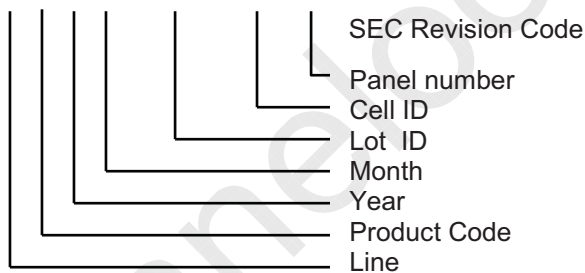

(4) Nameplate Indication

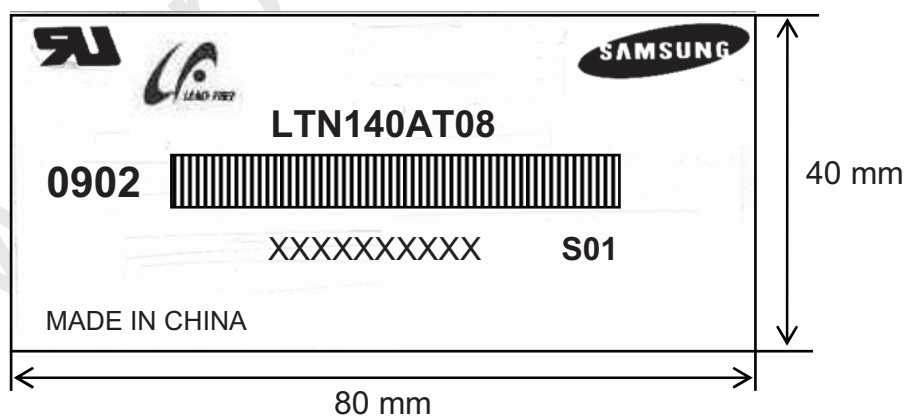

Parts name : LTN140AT08  
 Lot number : XXXXXXXXXXXX  
 Inspected work week : 0902(2009 year, 2nd week)

**Samsung Secret**

Approval

## (5) Packing small box attach

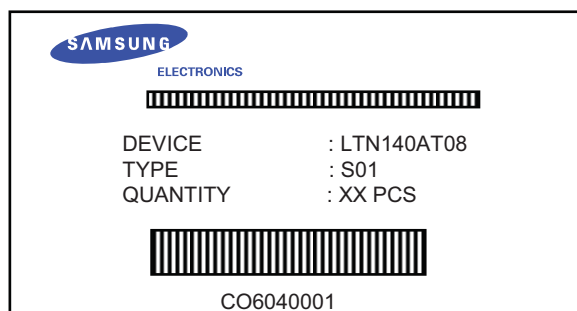

Samsung Secret

|                |                |               |                 |             |         |
|----------------|----------------|---------------|-----------------|-------------|---------|
| <b>Doc.No.</b> | LTN140AT08-S01 | <b>Rev.No</b> | 04-A00-G-090706 | <b>Page</b> | 25 / 27 |
|----------------|----------------|---------------|-----------------|-------------|---------|

Approval

**10. GENERAL PRECAUTIONS**

## 1. Handling

- (a) When the module is assembled, It should be attached to the system firmly using every mounting holes. Be careful not to twist and bend the modules.
- (b) Refrain from strong mechanical shock and / or any force to the module. In addition to damage, this may cause improper operation or damage to the module and LED back-light.
- (c) Note that polarizers are very fragile and could be easily damaged. Do not press or scratch the surface harder than a HB pencil lead.
- (d) Wipe off water droplets or oil immediately. If you leave the droplets for a long time, Staining and discoloration may occur.
- (e) If the surface of the polarizer is dirty, clean it using some absorbent cotton or soft cloth.
- (f) The desirable cleaners are water, IPA (Isoprophyl Alcohol) or Hexane. Do not use Ketone type materials(ex. Acetone), Ethyl alcohol, Toluene, Ethyl acid or Methyl chloride. It might permanent damage to the polarizer due to chemical reaction.
- (g) If the liquid crystal material leaks from the panel, it should be kept away from the eyes or mouth. In case of contact with hands, legs or clothes, it must be washed away thoroughly with soap.
- (h) Protect the module from static, it may cause damage to the C-MOS Gate Array IC.
- (i) Use fingerstalls with soft gloves in order to keep display clean during the incoming inspection and assembly process.
- (j) Do not disassemble the module.
- (k) Do not adjust the variable resistor which is located on the back side.
- (l) Protection film for polarizer on the module shall be slowly peeled off just before use so that the electrostatic charge can be minimized.
- (m) Pins of I/F connector shall not be touched directly with bare hands.

**Samsung Secret**

|                |                |               |                 |             |         |
|----------------|----------------|---------------|-----------------|-------------|---------|
| <b>Doc.No.</b> | LTN140AT08-S01 | <b>Rev.No</b> | 04-A00-G-090706 | <b>Page</b> | 26 / 27 |
|----------------|----------------|---------------|-----------------|-------------|---------|

Approval

## 2. STORAGE

- (a) Do not leave the module in high temperature, and high humidity for a long time.  
It is highly recommended to store the module with temperature from 0 to 35 °C and relative humidity of less than 70%.
- (b) Do not store the TFT-LCD module in direct sunlight.
- (c) The module shall be stored in a dark place. It is prohibited to apply sunlight or fluorescent light during the store.

## 3. OPERATION

- (a) Do not connect,disconnect the module in the " Power On" condition.
- (b) Power supply should always be turned on/off by following item 6.3 " Power on/off sequence " .
- (c) Module has high frequency circuits. Sufficient suppression to the electromagnetic interference shall be done by system manufacturers. Grounding and shielding methods may be important to minimize the interference.
- (d) The standard limited warranty is only applicable when the module is used for general notebook applications. If used for purposes other than as specified, SEC is not to be held reliable for the defective operations. It is strongly recommended to contact SEC to find out fitness for a particular purpose.

## 4. OTHERS

- (a) Ultra-violet ray filter is necessary for outdoor operation.
- (b) Avoid condensation of water. It may result in improper operation or disconnection of electrode.
- (c) Do not exceed the absolute maximum rating value. ( the supply voltage variation, input voltage variation, variation in part contents and environmental temperature, so on)  
Otherwise the module may be damaged.
- (d) If the module displays the same pattern continuously for a long period of time,it can be the situation when the image "sticks" to the screen.
- (e) This module has its circuitry PCB's on the rear side and should be handled carefully in order not to be stressed.

**Samsung Secret**

|                |                |               |                 |             |         |
|----------------|----------------|---------------|-----------------|-------------|---------|
| <b>Doc.No.</b> | LTN140AT08-S01 | <b>Rev.No</b> | 04-A00-G-090706 | <b>Page</b> | 27 / 27 |
|----------------|----------------|---------------|-----------------|-------------|---------|