



ELECTRONICS



Product Information

SAMSUNG TFT-LCD
MODEL NO. : LTN141AT02-101

LCD Development Team 3

Samsung Electronics Co . , LTD.



SAMSUNG TFT-LCD

Doc.No.	LTN141AT02-101	ISSUED DATE	19/Jun/2007	Page	1 / 13
---------	----------------	-------------	-------------	------	--------

CONTENTS

General Description	----- (3)
1. Electrical Absolute Ratings	----- (4)
2. Optical Characteristics	----- (5)
3. Electrical Characteristics	----- (6)
3.1 TFT LCD Module	
3.2 Backlight Unit	
4. Block Diagram	----- (7)
4.1 TFT LCD Module	
4.2 Backlight Unit	
5. Input Terminal Pin Assignment	----- (8)
5.1 Input Signal & Power	
5.2 Backlight Unit	
5.3 Timing Diagrams of LVDS For Transmitting	
6. Interface Timing	----- (10)
6.1 Timing Parameters	
6.2 Timing Diagrams of interface Signal	
6.3 Power ON/OFF Sequence	
7. Outline Dimension	----- (12)

GENERAL DESCRIPTION

DESCRIPTION

LTN141AT02-101 is a color active matrix TFT (Thin Film Transistor) liquid crystal display (LCD) that uses amorphous silicon TFT as switching devices. This model is composed of a TFT LCD panel, a driver circuit and a backlight system. The resolution of a 14.1" contains 1280 x 800 pixels and can display up to 262,144 colors. 6 O'clock direction is the Optimum viewing angle.

FEATURES

- High contrast ratio, high aperture structure
- Wide XGA (1280x800 pixels) resolution
- Low power consumption
- Single CCFL
- DE (Data enable) only mode.
- 3.3V LVDS Interface
- On board EDID chip
- Pb-free product

APPLICATIONS

- Notebook PC
- If the usage of this product is not for PC application, but for others, please contact SEC

GENERAL INFORMATION

Item	Specification	Unit	Note
Display area	303.36(H) x 189.6(V) (14.1" diagonal)	mm	
Driver element	a-Si TFT active matrix		
Display colors	262,144		
Number of pixel	1280 x 800	pixel	
Pixel arrangement	RGB vertical stripe		
Pixel pitch	0.2370(H) x 0.2370(V) (TYP.)	mm	
Display Mode	Normally white		
Surface treatment	Haze 25, Hard-Coating 3H		

MECHANICAL INFORMATION

Item		Min.	Typ.	Max.	Unit	Note
Module size	Horizontal (H)	319.0	319.5	320.0	mm	
	Vertical (V)	205.0	205.5	206.0	mm	
	Depth (D)	-	(5.2)	(5.5)	mm	(1)
Weight		-	(420)	(430)	g	

Note (1) Measurement condition of outline dimension
 . Equipment : Vernier Calipers
 . Push Force : 500g · f (minimum)

1. ELECTRICAL ABSOLUTE RATINGS

(1) TFT LCD MODULE

$$V_{DD} = 3.3V, V_{SS} = GND = 0V$$

Item	Symbol	Min.	Max.	Unit	Note
Power Supply Voltage	V_{DD}	$V_{DD} - 0.3$	$V_{DD} + 0.3$	V	(1)
Logic Input Voltage	V_{DD}	$V_{DD} - 0.3$	$V_{DD} + 0.3$	V	(1)

Note (1) Within T_a (25 ± 2 °C)

(2) BACK-LIGHT UNIT

$$T_a = 25 \pm 2$$
 °C

Item	Symbol	Min.	Max.	Unit	Note
Lamp Current	I_L	3.0	7.0	mArms	(1)
Lamp frequency	F_L	40	80	kHz	(1)

Note 1) Permanent damage to the device may occur if maximum values are exceeded
 Functional operation should be restricted to the conditions described under normal operating conditions.

2. OPTICAL CHARACTERISTICS

The following items are measured under stable conditions. The optical characteristics should be measured in a dark room or equivalent state.

Measuring equipment : TOPCON SR-3 and SR-3

* Ta = 25 ± 2 °C, VDD=3.3V, fv= 60Hz, fdCLK = 68.9MHz, IL = 6.0 mA

Item		Symbol	Condition	Min.	Typ.	Max	Unit
Contrast Ratio (5 Points)		CR	Normal Viewing Angle $\phi = 0$ $\theta = 0$	(200)	(300)	-	-
Response Time at Ta (Rising + Falling)		T _{RT}		-	(16)	(25)	msec
Average Luminance of White (5 Points)		Y _{L,AVE}		(165)	(190)	-	cd/m ²
Color Chromaticity (CIE)	Red	R _X	CR ≥ 10	(0.560)	(0.590)	(0.620)	-
		R _Y		(0.310)	(0.340)	(0.370)	
	Green	G _X		(0.290)	(0.320)	(0.350)	
		G _Y		(0.510)	(0.540)	(0.570)	
	Blue	B _X		(0.132)	(0.152)	(0.182)	
		B _Y		(0.090)	(0.120)	(0.150)	
	White	W _X		(0.283)	(0.313)	(0.343)	
		W _Y		(0.299)	(0.329)	(0.359)	
Viewing Angle	Hor.	θ_L	(40)	(45)	-	Degrees	
		θ_H	(40)	(45)	-		
	Ver.	ϕ_H	(10)	(15)	-		
		ϕ_L	(25)	(30)	-		
13 Points White Variation		δ_L		-	-	(1.8)	-

3. ELECTRICAL CHARACTERISTICS

3.1 TFT LCD MODULE

Ta= 25 ± 2°C

Item	Symbol	Min.	Typ.	Max.	Unit	Note	
Voltage of Power Supply	V _{DD}	3.0	3.3	3.6	V		
Differential Input Voltage for LVDS Receiver Threshold	High	V _{IH}	-	-	+100	mV	V _{CM} = +1.2V
	Low	V _{IL}	-100	-	-	mV	
Vsync Frequency	f _v	-	60	-	Hz		
Hsync Frequency	f _H	-	48.96	-	KHz		
Main Frequency	f _{DCLK}	-	68.9	-	MHz		
Rush Current	I _{RUSH}	-	-	1.5	A		
Current of Power Supply	White	I _{DD}	-	(340)	-	mA	
	Mosaic		-	(350)	-	mA	
	V. Stripe		-	(395)	(500)	mA	

3.2 BACK-LIGHT UNIT

The backlight system is an edge-lighting type with a single CCFT (Cold Cathode Fluorescent Tube).
The characteristics of a single lamp are shown in the following table.

- INVERTER : SEM SIC 130T

Ta= 25 ± 2 °C

Item	Symbol	Min.	Typ.	Max.	Unit	Note
Lamp Current	I _L	3.0	6.0	6.5	mArms	
Lamp Voltage	V _L	-	670	-	Vrms	I _L =6.0mA
Frequency	f _L	50	60	65	KHz	
Power Consumption	P _L		(4.02)		W	I _L =6.0mA
Operating Life Time	Hr	10,000			Hour	
Startup Voltage	V _s			(1125)	Vrms	25°C
				(1359)	Vrms	0°C
Lamp startup time		-	-	1.0	sec	

4. BLOCK DIAGRAM

4.1 TFT LCD Module

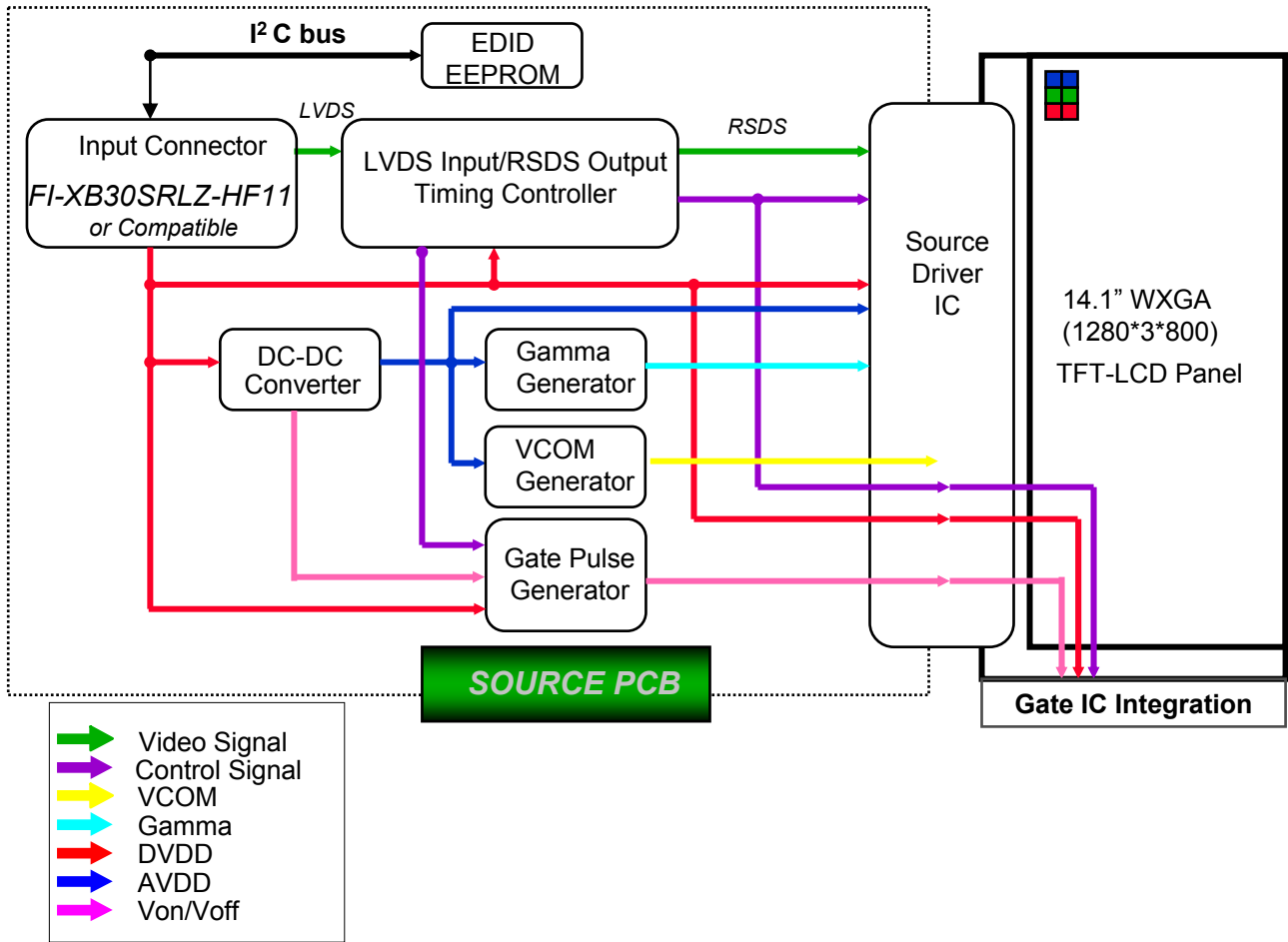

4.2 BACK-LIGHT UNIT

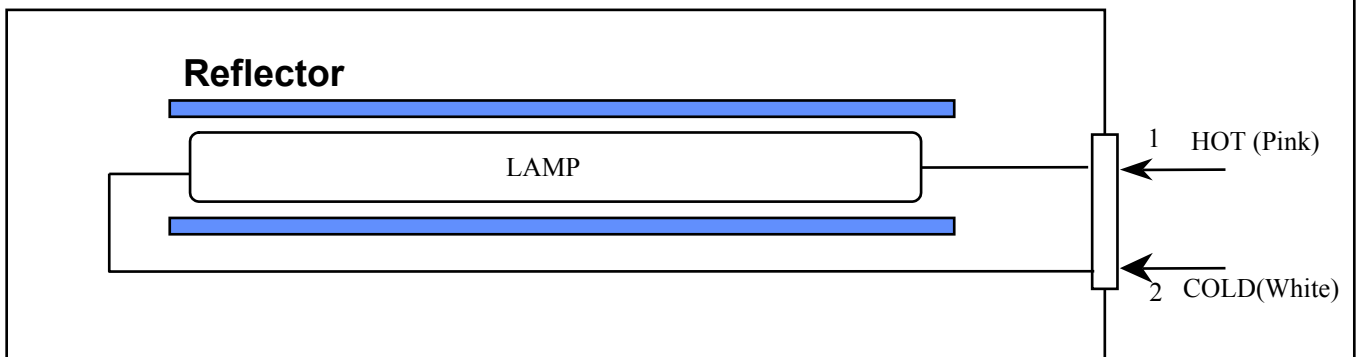

Note) The output of the inverter may change according to the material of the reflector.

5. INPUT TERMINAL PIN ASSIGNMENT

5.1. Input Signal & Power (LVDS, Connector : JAE FI-XB30SRLZ-HF11 or compatible)
Mating Connector : JAE FI-X30M or compatible)

PIN NO	SYMBOL	FUNCTION	POLARITY	REMARK
1	VSS	Ground		
2	VDD	POWER SUPPLY +3.3V		
3	VDD	POWER SUPPLY +3.3V		
4	VEEDID	DDC 3.3V Power		
5	NC	No Connection		
6	CLKEDID	DDC Clock		
7	DATAEDID	DDC data		
8	RxIN0-	LVDS Differential Data INPUT (R0-R5,G0)	Negative	
9	RxIN0+	LVDS Differential Data INPUT (R0-R5,G0)	Positive	
10	VSS	Ground		
11	RxIN1-	LVDS Differential Data INPUT (G1-G5,B0-B1)	Negative	
12	RxIN1+	LVDS Differential Data INPUT (G1-G5,B0-B1)	Positive	
13	VSS	Ground		
14	RxIN2-	LVDS Differential Data INPUT (B2-B5,Sync,DE)	Negative	
15	RxIN2+	LVDS Differential Data INPUT (B2-B5,Sync,DE)	Positive	
16	VSS	Ground		
17	RxCLK-	LVDS Differential Data INPUT (Clock)	Negative	
18	RxCLK+	LVDS Differential Data INPUT (Clock)	Positive	
19	VSS	Ground		
20	NC	No Connection		
21	NC	No Connection		
22	NC	No Connection		
23	NC	No Connection		
24	NC	No Connection		
25	NC	No Connection		
26	NC	No Connection		
27	NC	No Connection		
28	NC	No Connection		
29	NC	No Connection		
30	NC	No Connection		

5.2 BACK LIGHT UNIT

Connector : JST BHSR - 02VS -1
 Mating Connector : SM02B-BHSS-1(JST)

Pin NO.	Symbol	Color	Function
1	HOT	Pink	High Voltage
2	COLD	White	Low Voltage

5.3 Timing Diagrams of LVDS For Transmission

LVDS Receiver : Integrated T-CON

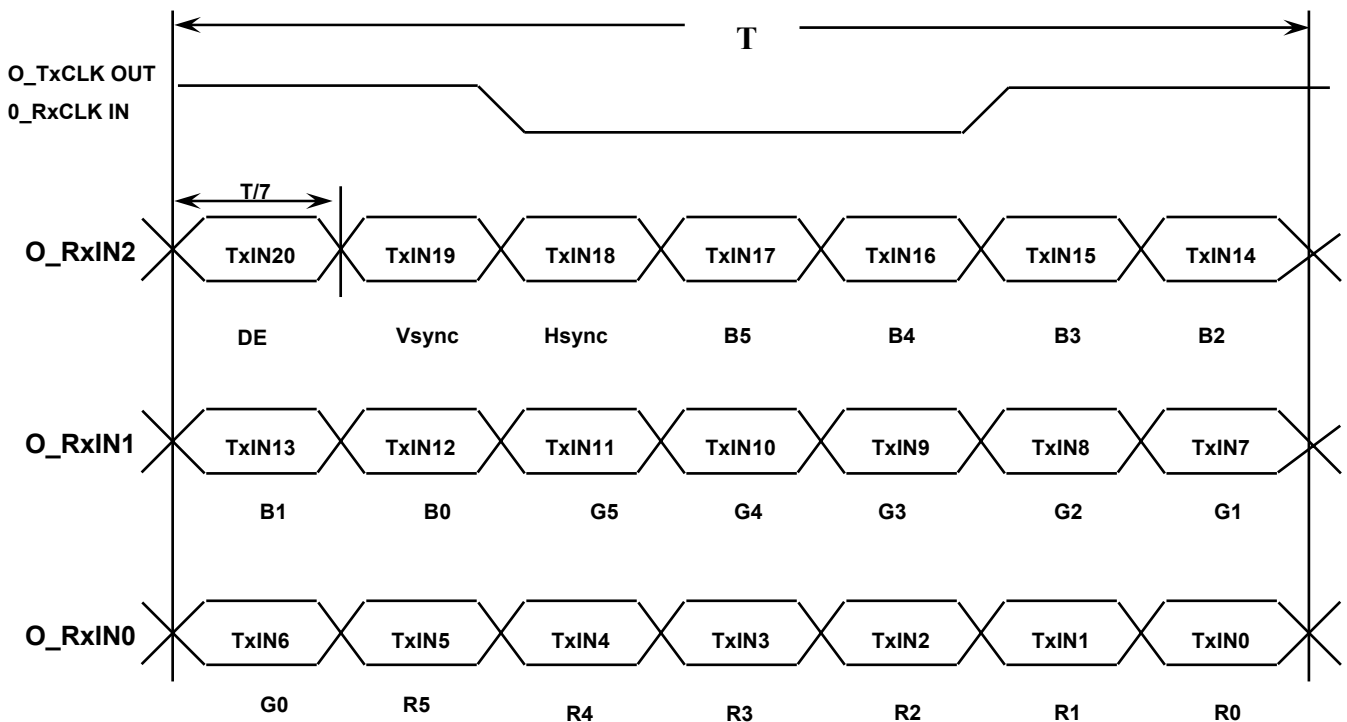

6. INTERFACE TIMING

6.1 Timing Parameters

Signal	Item	Symbol	Min.	Typ.	Max.	Unit	Note
Frame Frequency	Cycle	TV	(804)	(816)	(833)	Lines	-
Vertical Active Display Term	Display Period	TVD	-	(800)	-	Lines	-
One Line Scanning Time	Cycle	TH	(1316)	(1408)	(1500)	Clocks	-
Horizontal Active Display Term	Display Period	THD	-	(1280)	-	Clocks	-

6.2 Timing diagrams of interface signal

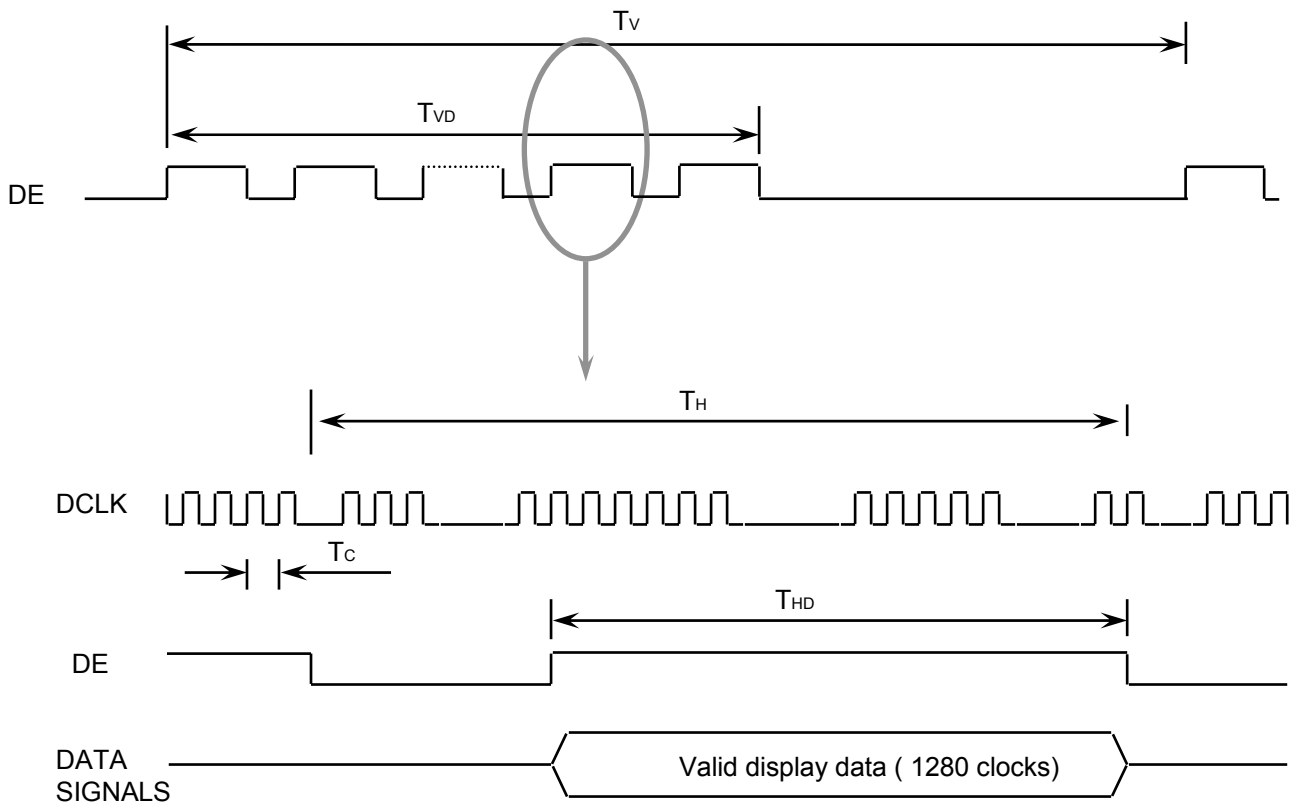

6.3 Power ON/OFF Sequence

: To prevent a latch-up or DC operation of the LCD module, the power on/off sequence should be as the diagram below.

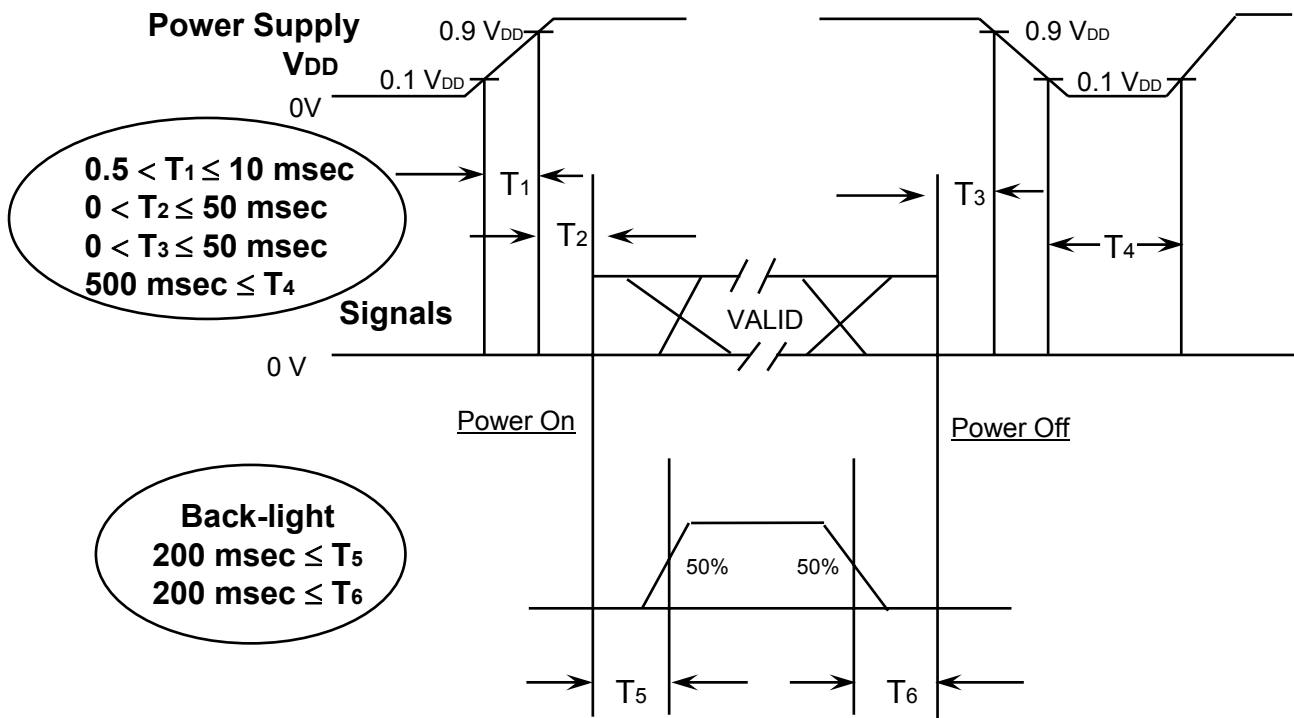

Power ON/OFF Sequence

- T1 : Vdd rising time from 10% to 90%
- T2 : The time from Vdd to valid data at power ON.
- T3 : The time from valid data off to Vdd off at power Off.
- T4 : Vdd off time for Windows restart
- T5 : The time from valid data to B/L enable at power ON.
- T6 : The time from valid data off to B/L disable at power Off.

NOTE.

- (1) The supply voltage of the external system for the module input should be the same as the definition of VDD.
- (2) Apply the lamp voltage within the LCD operation range. When the back-light turns on before the LCD operation or the LCD turns off before the back-light turns off, the display may momentarily become white.
- (3) In case of VDD = off level, please keep the level of input signals on the low or keep a high impedance.
- (4) T4 should be measured after the module has been fully discharged between power off and on period.
- (5) Interface signal shall not be kept at high impedance when the power is on.

7. MECHANICAL OUTLINE DIMENSION

[Refer to the next page]

Doc.No.	LTN141AT02-101	ISSUED DATE	19/Jun/2007	Page	12 / 13
----------------	----------------	--------------------	-------------	-------------	---------

NO	PART NAME	CODE NO	SPECIFICATION	Q'TY	WEIGHT	UNIT	REASON	CHK'D BY
1	LTN141AT02-001	DDS****		1EA				

SCREW PENETRATION DEPTH

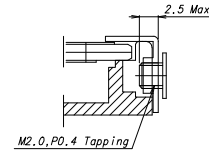

SECTION A-A' (S=5/1)

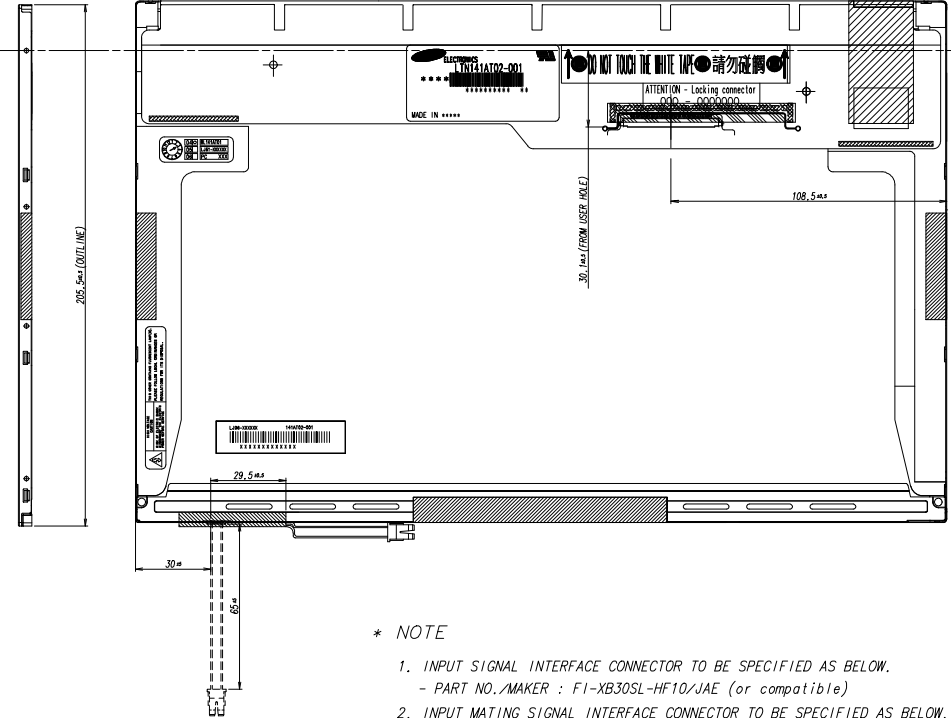
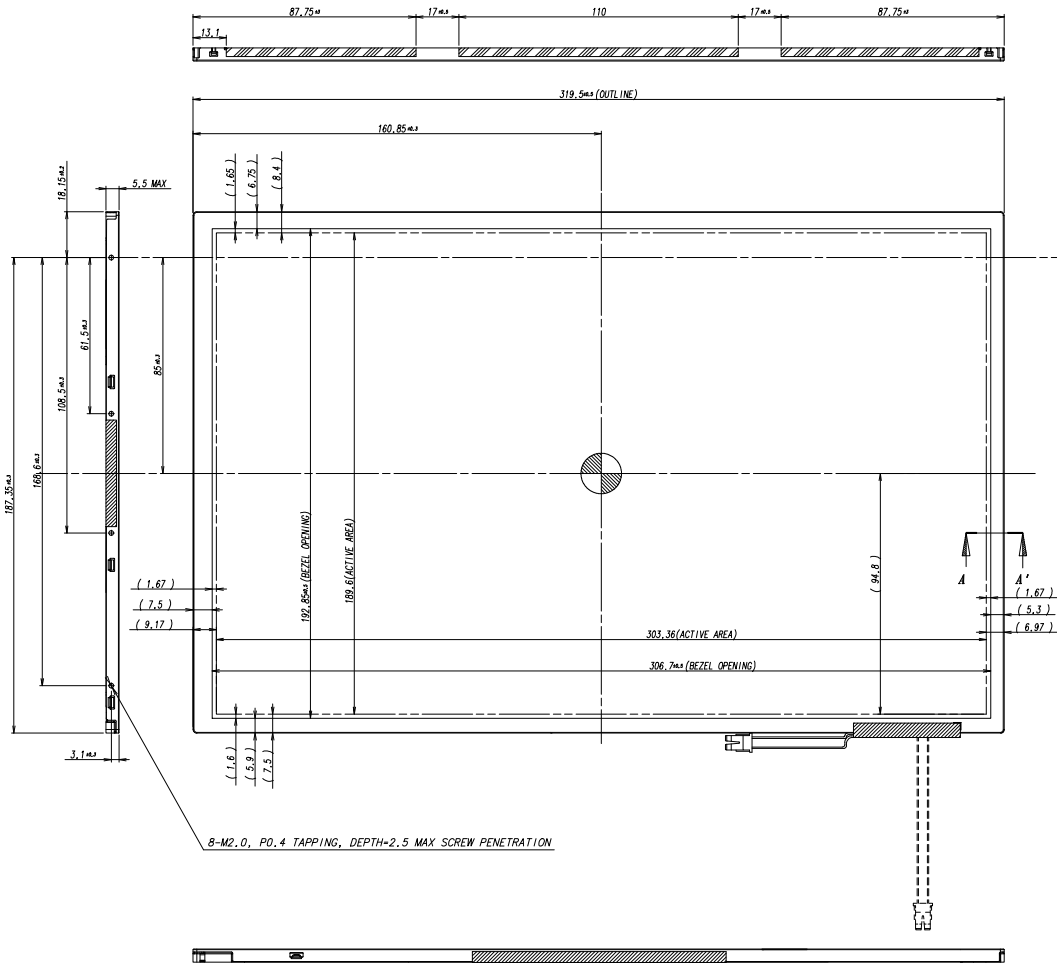

* NOTE

- INPUT SIGNAL INTERFACE CONNECTOR TO BE SPECIFIED AS BELOW.
- PART NO./MAKER : FI-XB30SL-HF10/JAE (or compatible)
- INPUT MATING SIGNAL INTERFACE CONNECTOR TO BE SPECIFIED AS BELOW.
- PART NO./MAKER : FI-X30M/JAE (or compatible)
- CCFT CONNECTOR FOR BACKLIGHT TO BE SPECIFIED AS BELOW.
- PART NO./MAKER : BHSR-02VS-1/JST (or compatible)
- CALIFERS MEASURING FORCE : 530 ± 150 gf
- USER HOLE TORQUE SPEC : 2.5Kgfcm MAX (5 TIMES)
- WEIGHT SPEC : 430g MAX

REV NO

GENERAL TOLERANCE				REV	DATE	DESCRIPTION OF REVISION				REASON		CHK'D BY
STEP	LEVEL 1	LEVEL 2	LEVEL 3	UNIT	NO	DRAWN BY	DES'D BY	CHK'D BY	APP'D BY	MODEL NAME	PART/SHEET NAME	SHEET
0 < X ≤ 4	±0.05	±0.1	±0.2	mm	1	S.D.PARK		Y.J.LEE	D.C.PARK	LTN141AT02-001	Outline-Dimension	1/1
4 < X ≤ 16	±0.08	±0.15	±0.3									
16 < X ≤ 64	±0.12	±0.25	±0.5									
64 < X ≤ 256	±0.25	±0.4	±0.8									
SAMSUNG ELECTRONICS										SPEC. NO		
										CODE NO.		VER. 000