



ELECTRONICS

Preliminary



TO : 
DATE : Jun. 1, 2007.

SAMSUNG TFT-LCD
MODEL NO. : LTN141AT03-101

NOTE : Surface type [**Glare**]

The information described in this SPEC is preliminary and can be changed without prior notice.

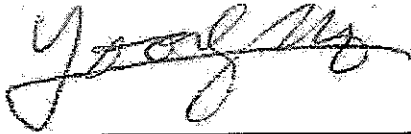
APPROVED BY : 

PREPARED BY : LCD Development Team 3

SAMSUNG ELECTRONICS CO., LTD.



Samsung Secret

Preliminary

CONTENTS

Revision History	-----	(3)
General Description	-----	(4)
1. Absolute Maximum Ratings	-----	(5)
1.1 Absolute Ratings of environment		
1.2 Electrical Absolute Ratings		
2. Optical Characteristics	-----	(7)
3. Electrical Characteristics	-----	(10)
3.1 TFT LCD Module		
3.2 Backlight Unit		
3.3 Inverter		
4. Block Diagram	-----	(13)
4.1 TFT LCD Module		
4.2 Backlight Unit		
5. Input Terminal Pin Assignment	-----	(14)
5.1 Input Signal & Power		
5.2 LVDS Interface		
5.3 Backlight Unit		
5.4 Timing Diagrams of LVDS For Transmitting		
5.5 Input Signals, Basic Display Colors and Gray Scale of Each Color.		
5.6 Pixel format		
6. Interface Timing	-----	(19)
6.1 Timing Parameters		
6.2 Timing Diagrams of interface Signal		
6.3 Power ON/OFF Sequence		
7. Outline Dimension	-----	(21)
8. General Precaution	-----	(23)
9. EDID	-----	(25)

Samsung Secret

REVISION HISTORY

Preliminary

Date	Revision No.	Page	Summary
Jun. 1, 2007	P00	All	The specification of 141AT03-101 model was issued first.

Samsung Secret

Preliminary

GENERAL DESCRIPTION**DESCRIPTION**

LTN141AT03-101 is a color active matrix TFT (Thin Film Transistor) liquid crystal display (LCD) that uses amorphous silicon TFT as a switching devices. This model is composed of a TFT LCD panel, a driver circuit and a backlight unit. The resolution of a 14.1" contains 1280 x 800 pixels and can display up to 262,144 colors. 6 O'clock direction is the Optimum viewing angle.

FEATURES

- High contrast ratio, high aperture structure
- WXGA (1280 x 800 pixels) resolution
- Low power consumption
- Fast Response
- Single CCFL
- DE(Data enable) only mode
- 3.3V LVDS Interface
- Onboard EDID chip
- Pb-free product

APPLICATIONS

- Notebook PC
- If the usage of this product is not for PC application, but for others, please contact SEC

GENERAL INFORMATION

Item	Specification	Unit	Note
Display area	303.36(H) x 189.6(V) (14.1" diagonal)	mm	
Driver element	a-Si TFT active matrix		
Display colors	262,144		
Number of pixel	1280 x 800	pixel	
Pixel arrangement	RGB vertical stripe		
Pixel pitch	0.2370(H) x 0.2370(V) (TYP.)	mm	
Display Mode	Normally white		
Surface treatment	Haze 0, Hard-Coating 3H		

Samsung Secret

Doc.No.	LTN141AT03-101	Rev.No	04-P00-G-070601	Page	4 / 27
---------	----------------	--------	-----------------	------	--------

Preliminary

Mechanical Information

Item		Min.	Typ.	Max.	Unit	Note
Module size	Horizontal (H)	319.0	319.5	320.0	mm	
	Vertical (V)	205.0	205.5	206.0	mm	
	Depth (D)	-	(5.2)	(5.5)	mm	
Weight		-	(420)	(430)	g	

Note (1) Measurement condition of outline dimension
 . Equipment : Bernier Calipers
 . Push Force : 500g · f (minimum)

1. ABSOLUTE MAXIMUM RATINGS

1.1 ENVIRONMENTAL ABSOLUTE RATINGS

Item	Symbol	Min.	Max.	Unit	Note
Storage temperate	TSTG	-20	60	°C	(1)
Operating temperate (Temperature of glass surface)	TOPR	0	50	°C	(1)
Shock (non-operating)	Snop	-	240	G	(2),(4)
Vibration (non-operating)	Vnop	-	2.41	G	(3),(4)

Note (1) Temperature and relative humidity range are shown in the figure below.
 95 % RH Max. (40 °C ≥ Ta)
 Maximum wet - bulb temperature at 39 °C or less. (Ta > 40 °C) No condensation

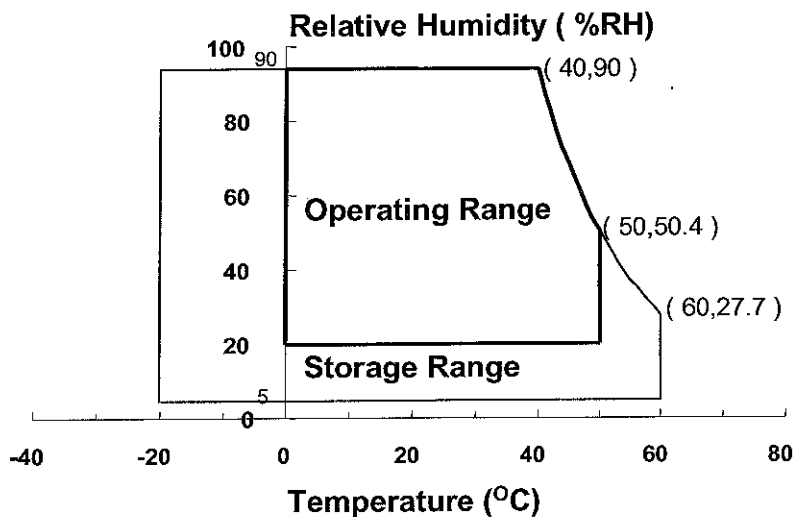

- (2) 2ms, half sine wave, one time for ±X, ±Y, ±Z.
- (3) 5 - 500 Hz, random vibration, 30min for X, Y, Z.
- (4) At testing Vibration and Shock, the fixture in holding the Module to be tested have to be hard and rigid enough so that the Module would not be twisted or bent by the fixture.

Samsung Secret

Preliminary

1.2 ELECTRICAL ABSOLUTE RATINGS

(1) TFT LCD MODULE

 $V_{DD} = 3.3V, V_{SS} = GND = 0V$

Item	Symbol	Min.	Max.	Unit	Note
Power Supply Voltage	V_{DD}	$V_{DD} - 0.3$	$V_{DD} + 0.3$	V	(1)
Logic Input Voltage	V_{IN}	$V_{DD} - 0.3$	$V_{DD} + 0.3$	V	(1)

Note (1) Within T_a (25 ± 2 °C)

(2) BACK-LIGHT UNIT

 $T_a = 25 \pm 2$ °C

Item	Symbol	Min.	Max.	Unit	Note
Lamp Current	I_L	3.0	7.0	mArms	(1)
Lamp frequency	F_L	40	80	kHz	(1)

Note 1) Permanent damage to the device may occur if maximum values are exceeded
 Functional operation should be restricted to the conditions described under normal operating conditions.

Samsung Secret

Preliminary

2. OPTICAL CHARACTERISTICS

The following items are measured under stable conditions. The optical characteristics should be measured in a dark room or equivalent state with the methods shown in Note (5).
Measuring equipment : TOPCON SR-3 and SR-3

* Ta = 25 ± 2 °C, VDD=3.3V, fv= 60Hz, fDCLK = 68.9MHz, IL = 6.0 mA

Item		Symbol	Condition	Min.	Typ.	Max	Unit	Note
Contrast Ratio (5 Points)		CR	Normal Viewing Angle $\phi = 0$ $\theta = 0$	(200)	(300)	-	-	(1), (2), (5)
Response Time at Ta (Rising + Falling)		T _{RT}		-	(16)	(25)	msec	(1), (3)
Average Luminance of White (5points)		Y _{L,AVE}		(170)	(200)	-	cd/m ²	IL=6.0mA (1), (4)
Color Chromaticity (CIE)	Red	R _X	CR ≥ 10 At center	(0.560)	(0.590)	(0.620)	-	(1), (5) SR-3
		R _Y		(0.310)	(0.340)	(0.370)		
	Green	G _X		(0.290)	(0.320)	(0.350)		
		G _Y		(0.510)	(0.540)	(0.570)		
	Blue	B _X		(0.132)	(0.152)	(0.182)		
		B _Y		(0.090)	(0.120)	(0.150)		
	White	W _X		(0.283)	(0.313)	(0.343)		
		W _Y		(0.299)	(0.329)	(0.359)		
Viewing Angle	Hor.	θ_L	(40)	(45)		Degrees	(1), (5) SR-3	
		θ_H	(40)	(45)				
	Ver.	ϕ_H	(10)	(20)				
		ϕ_L	(25)	(45)				
13 Points White Variation		δ_L		-	-	(1.8)	-	(6)

Samsung Secret

Preliminary

Note 1) Definition of Viewing Angle : Viewing angle range($10 \leq C/R$)

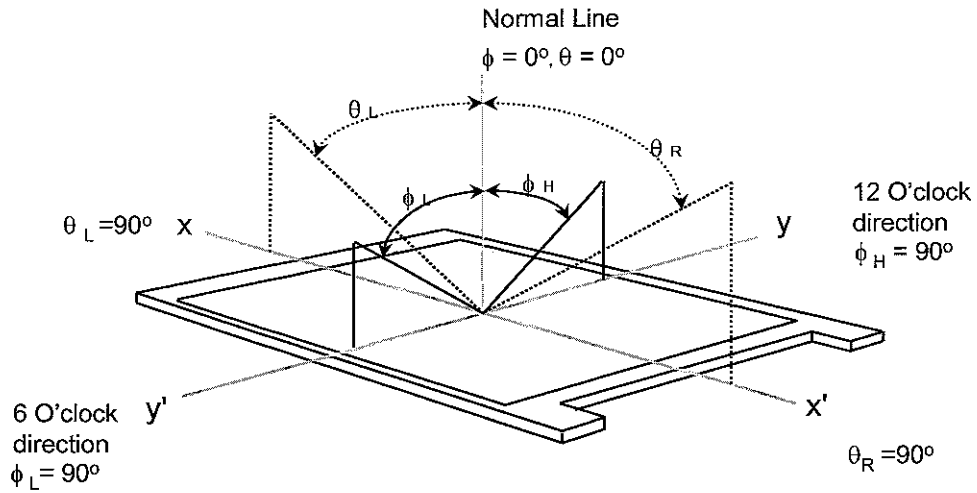

Note 2) Definition of Contrast Ratio (CR) : Ratio of gray max (Gmax) ,gray min (Gmin) at 5 points(4, 5, 7, 9, 10)

$$CR = \frac{CR(4) + CR(5) + CR(7) + CR(9) + CR(10)}{5}$$

Points : (4) , (5) , (7) , (9) , (10) at the figure of Note (6).

Note 3) Definition of Response time :

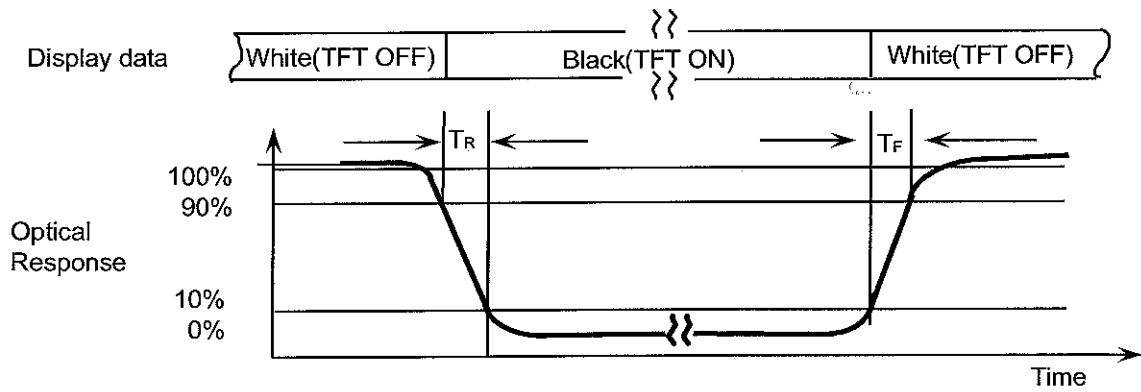

Note 4) Definition of Average Luminance of White : measure the luminance of white at 5 points.

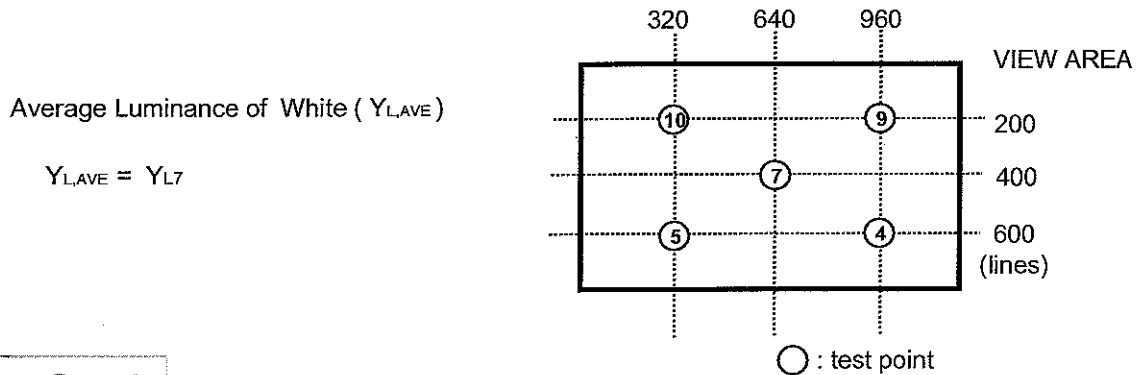

Average Luminance of White ($Y_{L,AVE}$)

$$Y_{L,AVE} = Y_{L7}$$

Samsung Secret

Preliminary

Note 5) After stabilizing and leaving the panel alone at a given temperature for 30 min , the measurement should be executed. Measurement should be executed in a stable, windless, and dark room. 30 min after lighting the backlight. This should be measured in the center of screen.
 Lamp current : 6.0mA (Inverter : SIC-130T)
 Environment condition : Ta = 25 ± 2 °C

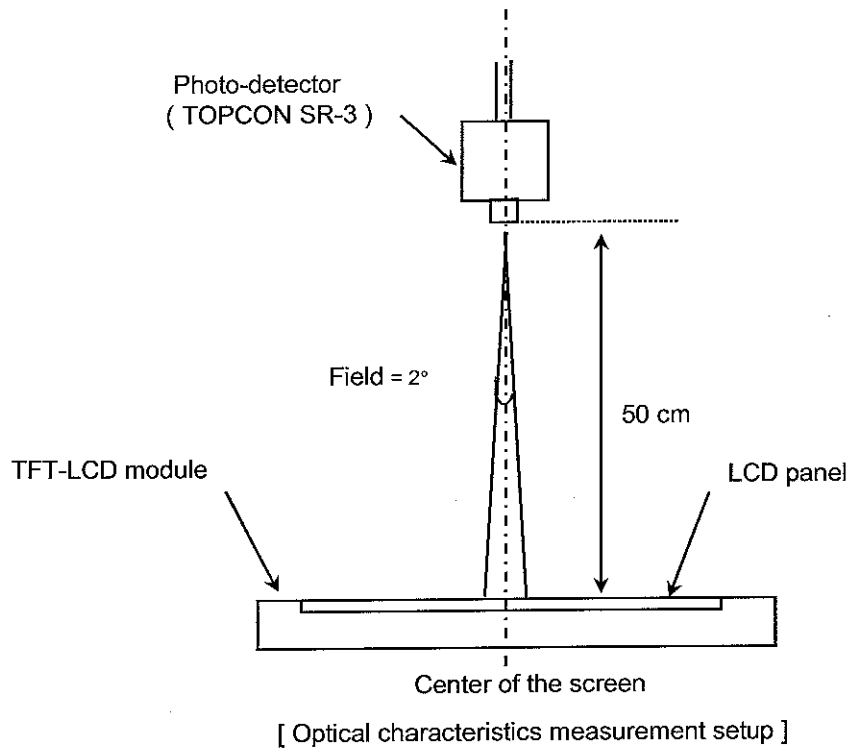

Note 6) Definition of 13 points white variation (δL), CR variation (C_{VER}) [① ~ ⑬]

$$\delta L = \frac{\text{Maximum luminance of 13 points}}{\text{Minimum luminance of 13 points}}$$

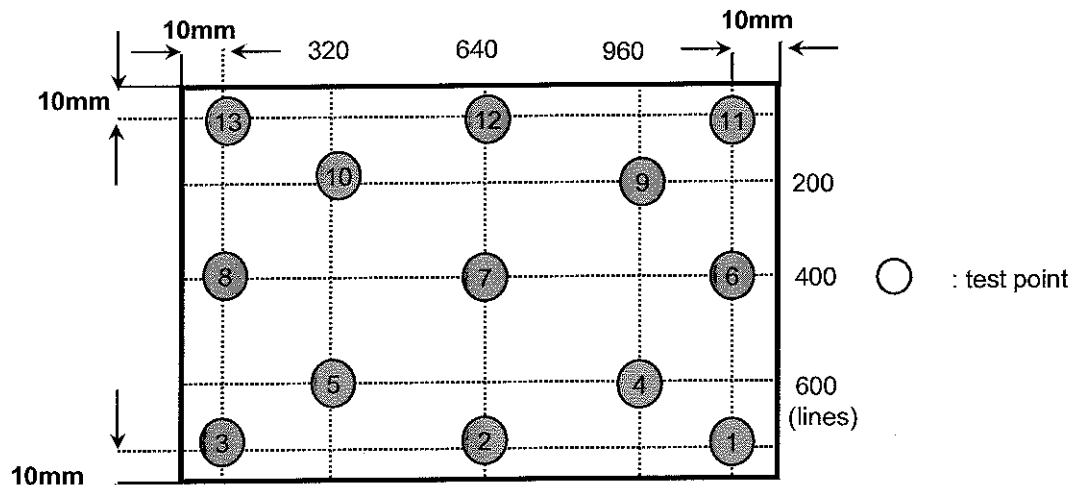

Samsung Secret

Preliminary

3. ELECTRICAL CHARACTERISTICS

3.1 TFT LCD MODULE

Ta= 25 ± 2°C

Item	Symbol	Min.	Typ.	Max.	Unit	Note	
Voltage of Power Supply	V _{DD}	3.0	3.3	3.6	V		
Differential Input Voltage for LVDS Receiver Threshold	High	V _{IH}	-	-	+100	mV	V _{CM} = +1.2V
	Low	V _{IL}	-100	-	-	mV	
Vsync Frequency	f _v	-	60	-	Hz		
Hsync Frequency	f _H	-	48.96	-	KHz		
Main Frequency	f _{DCLK}	-	68.9	-	MHz		
Rush Current	I _{RUSH}	-	-	1.5	A	(4)	
Current of Power Supply	White	I _{DD}	-	(300)	-	mA	(2),(3)*a
	Mosaic		-	(350)	-	mA	(2),(3)*b
	V. stripe		-	(395)	(500)	mA	(2),(3)*c

Note (1) Display data pins and timing signal pins should be connected.(GND = 0V)

(2) f_v = 60Hz, f_{DCLK} = 68.9MHz, V_{DD} = 3.3V , DC Current.

(3) Power dissipation pattern

*a) White Pattern

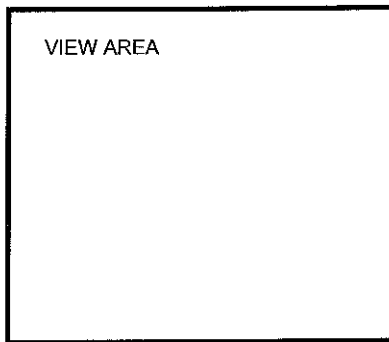

*b) Mosaic Pattern

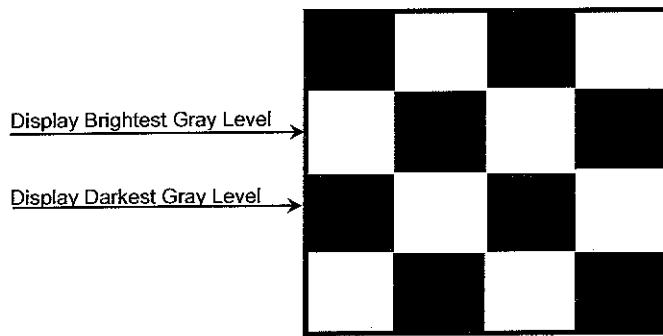

Samsung Secret

Preliminary

*c) 1dot Vertical stripe pattern

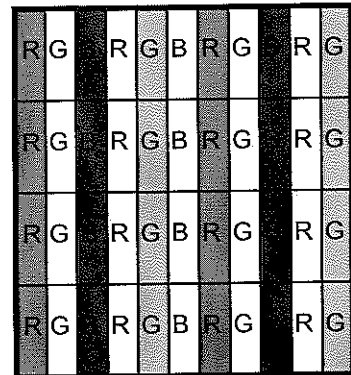
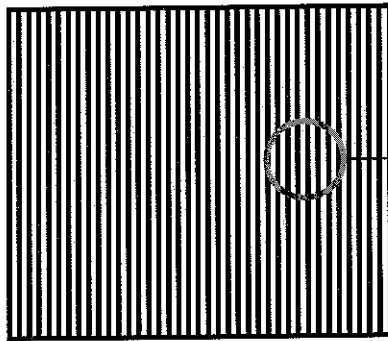

4) Rush current measurement condition

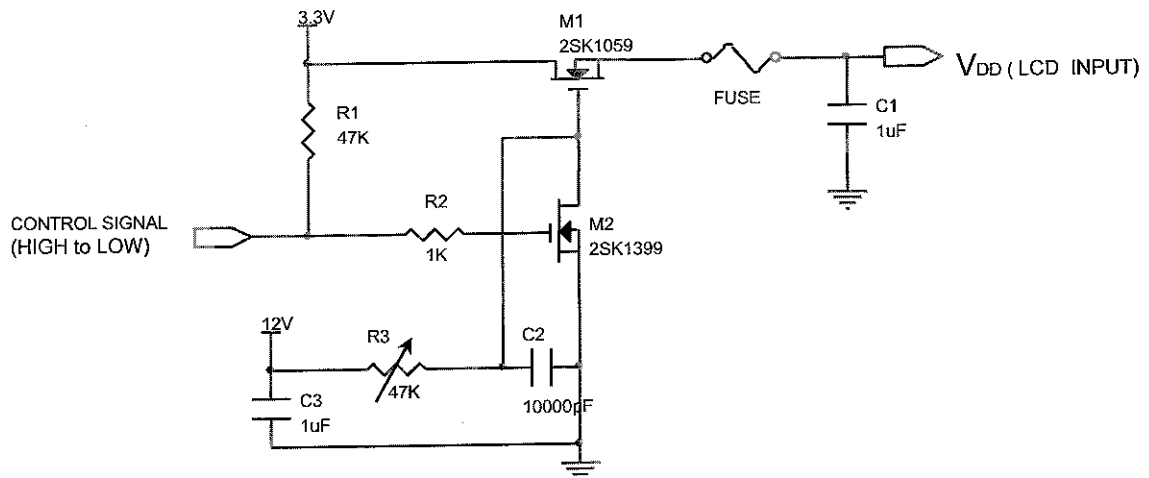

V_{DD} rising time is 470us

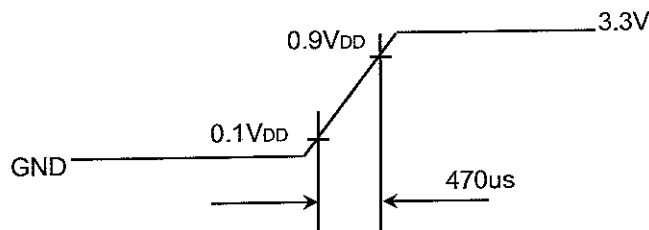

Samsung Secret

Preliminary

3.2 BACK-LIGHT UNIT

The backlight system is an edge-lighting type with a single CCFT (Cold Cathode Fluorescent Tube).
The characteristics of a single lamp are shown in the following table.

- INVERTER : SEM SIC 130T

Ta= 25 ± 2 °C

Item	Symbol	Min.	Typ.	Max.	Unit	Note
Lamp Current	I _L	3.0	6.0	6.5	mArms	(1)
Lamp Voltage	V _L	-	670	-	Vrms	I _L = 6.0mA
Frequency	f _L	50	60	65	KHz	(2)
Power Consumption	P _L		(4.02)		W	(3) I _L = 6.0mA
Operating Life Time	Hr	10,000			Hour	(4)
Startup Voltage	V _s			(1125)	Vrms	25°C, (5)
				(1359)	Vrms	0°C, (5)
Lamp Start-up time	T _s	-	-	1.0	sec	

Note) The waveform of the inverter output voltage must be area symmetric and the design of the inverter must have specifications for the modularized lamp.

The performance of the backlight, for example life time or brightness, is much influenced by the characteristics of the DC-AC inverter for the lamp. So all the parameters of an inverter should be carefully designed so as not to produce too much leakage current from high-voltage output of the inverter. When you design or order the inverter, please make sure that a poor lighting caused by the mismatch of the backlight and the inverter (miss lighting, flicker, etc.) never occur. When you confirm it, the module should be operated in the same condition as it is installed in your instrument.

Note (1) Lamp current is measured with a high frequency current meter as shown below.

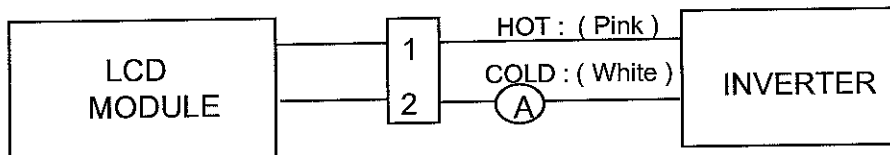

(2) Lamp frequency may produce interference with horizontal synchronous frequency and this may cause line flow on the display. Therefore lamp frequency should be detached from the horizontal synchronous frequency and its harmonics as far as possible in order to avoid interference.

(3) Refer to I_L × V_L to calculate.

(4) Life time (Hr) of a lamp can be defined as the time in which it continues to operate under the condition Ta= 25 ± 2 °C and I_L = 6.0 mArms until one of the following event occurs.

1. When the brightness becomes 50% or lower than the original.
2. When the Effective ignition length becomes 80% or lower than the original value.
(Effective ignition length is defined as an area that has less than 70% brightness compared to the brightness in the center point.)

(5) The inverter open voltage - this voltage should be measured after ballast capacitor- have to be larger than the lamp startup voltage, otherwise backlight may has blinking for a moment after turns on or not be turned on.
If an inverter has shutdown function it should keep its open voltage for longer than 1 second even if lamp connector open.

Samsung Secret

Preliminary

4. BLOCK DIAGRAM

4.1 TFT LCD Module

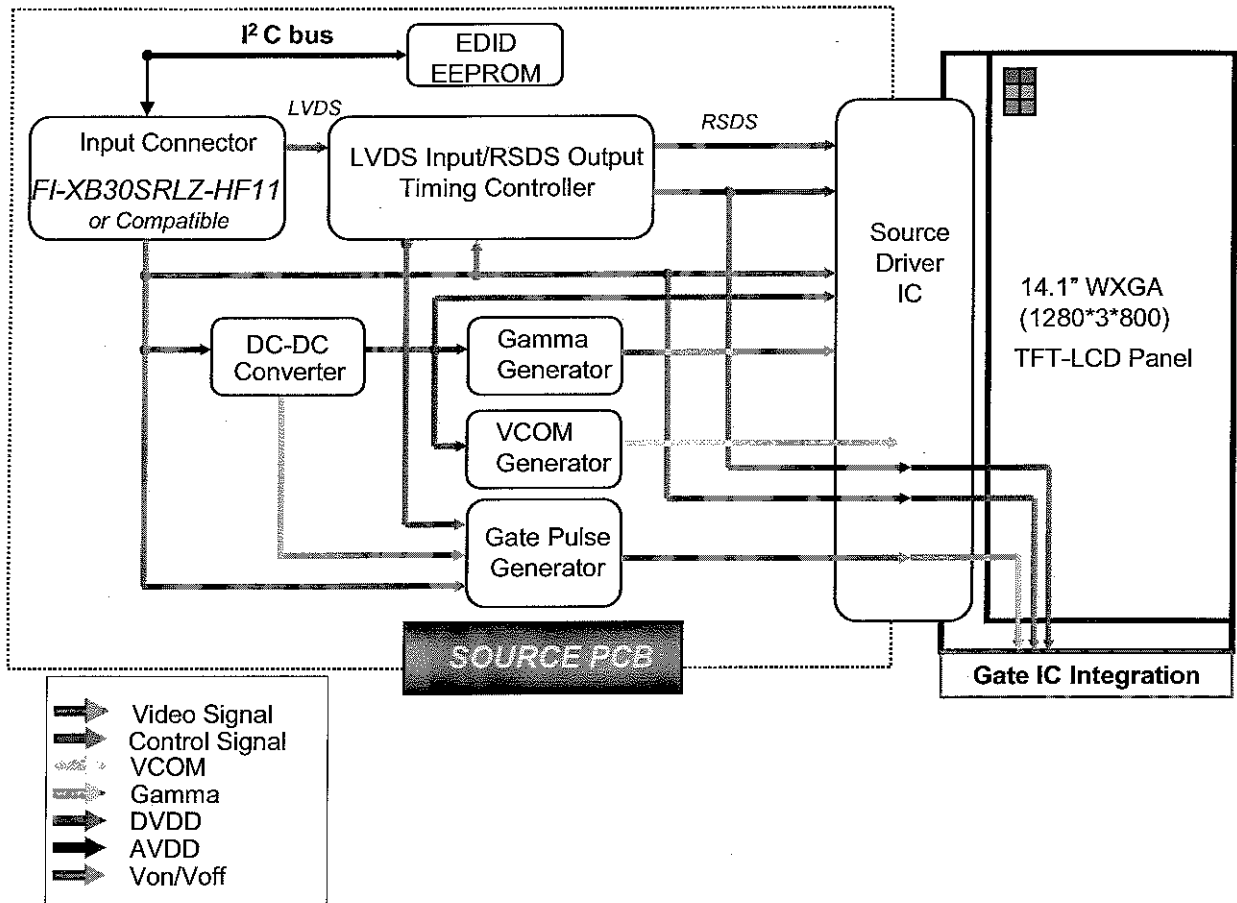

4.2 BACKLIGHT UNIT

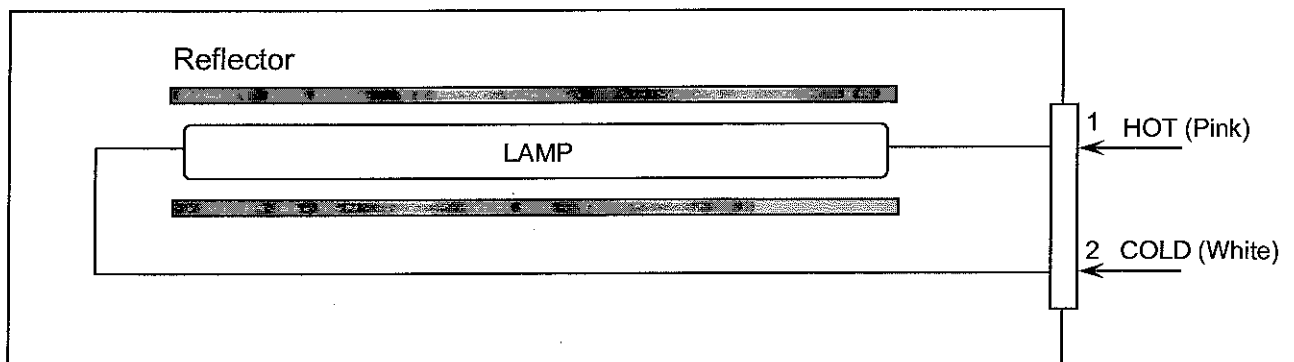

Note) The output of the inverter may change according to the material of the reflector.

Samsung Secret

Preliminary

5. INPUT TERMINAL PIN ASSIGNMENT

5.1. Input Signal & Power (LVDS, Connector : JAE FI-XB30SRLZ-HF11 or compatible)
Mating Connector : JAE FI-X30M or compatible)

No.	Symbol	Function	Polarity	Remarks
1	VSS	Ground		
2	VDD	POWER SUPPLY +3.3V		
3	VDD	POWER SUPPLY +3.3V		
4	VEEDID	DDC 3.3V Power		
5	NC	No connect		
6	CLKEDID	DDC Clock		
7	DATAEDID	DDC data		
8	RxIN0-	LVDS Differential Data INPUT (R0-R5,G0)	Negative	
9	RxIN0+	LVDS Differential Data INPUT (R0-R5,G0)	Positive	
10	GND	Ground		
11	RxIN1-	LVDS Differential Data INPUT (G1-G5,B0-B1)	Negative	
12	RxIN1+	LVDS Differential Data INPUT (G1-G5,B0-B1)	Positive	
13	GND	Ground		
14	RxIN2-	LVDS Differential Data INPUT (B2-B5,Sync,DE)	Negative	
15	RxIN2+	LVDS Differential Data INPUT (B2-B5,Sync,DE)	Positive	
16	Vss	Ground		
17	ClkIN-	LVDS Differential Clock INPUT	Negative	
18	ClkIN+	LVDS Differential Clock INPUT	Positive	
19	Vss	Ground		
20	NC	No connect		
21	NC	No connect		
22	NC	No connect		
23	NC	No connect		
24	NC	No connect		
25	NC	No connect		
26	NC	No connect		
27	NC	No connect		
28	NC	No connect		
29	NC	No connect		
30	NC	No connect		

Samsung Secret

Preliminary

5.2 LVDS Interface : Transmitter DS90CF363 or Compatible

Pin No.	Name	RGB Signal	Pin No.	Name	RGB Signal
44	TxIN0	RO0	12	TxIN11	GO5
45	TxIN1	RO1	13	TxIN12	BO0
47	TxIN2	RO2	15	TxIN13	BO1
48	TxIN3	RO3	16	TxIN14	BO2
1	TxIN4	RO4	18	TxIN15	BO3
3	TxIN5	RO5	19	TxIN16	BO4
4	TxIN6	GO0	20	TxIN17	BO5
6	TxIN7	GO1	22	TxIN18	Hsync
7	TxIN8	GO2	23	TxIN19	Vsync
9	TxIN9	GO3	25	TxIN20	DE
10	TxIN10	GO4	26	TxCLK IN	Clock

LVDS Interface

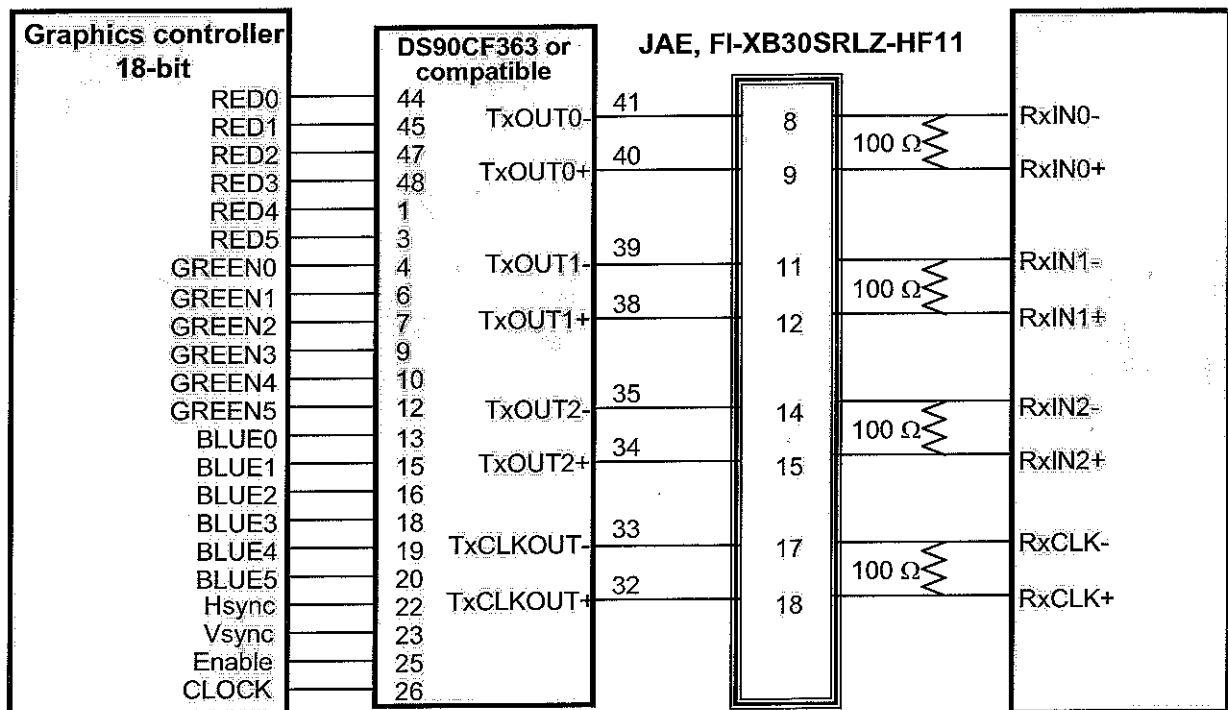

Note : The LCD Module uses a 100ohm resistor between positive and negative lines of each receiver input.

Samsung Secret

Preliminary

5.3 BACK LIGHT UNIT

Connector : JST BHSR - 02VS -1
 Mating Connector : SM02B-BHSS-1(JST)

Pin NO.	Symbol	Color	Function
1	HOT	Pink	High Voltage
2	COLD	White	Low Voltage

5.4 Timing Diagrams of LVDS For Transmission

LVDS Receiver : Integrated T-CON

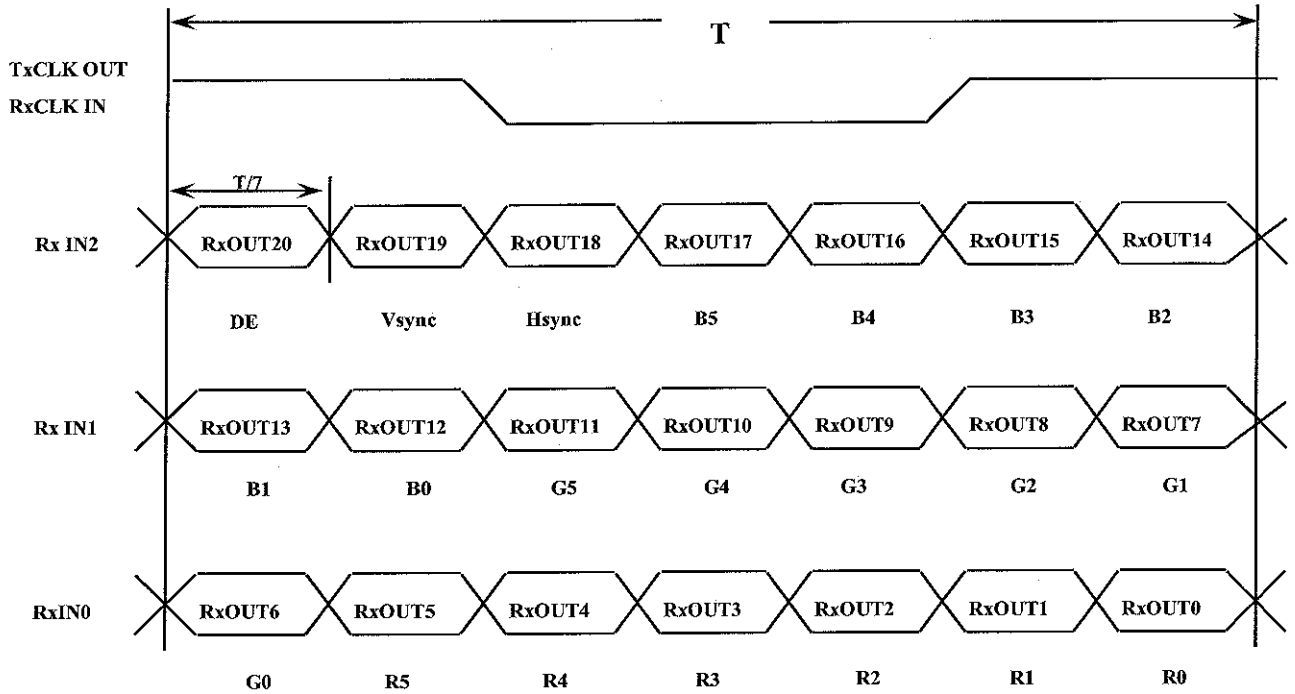

Samsung Secret

Preliminary

5.5 Input Signals, Basic Display Colors and Gray Scale of Each Color

Color	Display	Data Signal															Gray Scale Level		
		Red					Green					Blue							
		R0	R1	R2	R3	R4	R5	G0	G1	G2	G3	G4	G5	B0	B1	B2		B3	B4
Basic Colors	Black	0	0	0	0	0	0	0	0	0	0	0	0	0	0	0	0	0	-
	Blue	0	0	0	0	0	0	0	0	0	0	0	0	1	1	1	1	1	-
	Green	0	0	0	0	0	0	1	1	1	1	1	1	0	0	0	0	0	-
	Cyan	0	0	0	0	0	0	1	1	1	1	1	1	1	1	1	1	1	-
	Red	1	1	1	1	1	1	0	0	0	0	0	0	0	0	0	0	0	-
	Magenta	1	1	1	1	1	1	0	0	0	0	0	0	1	1	1	1	1	-
	Yellow	1	1	1	1	1	1	1	1	1	1	1	1	0	0	0	0	0	-
	White	1	1	1	1	1	1	1	1	1	1	1	1	1	1	1	1	1	-
Gray Scale Of Red	Black	0	0	0	0	0	0	0	0	0	0	0	0	0	0	0	0	0	R0
	Dark	1	0	0	0	0	0	0	0	0	0	0	0	0	0	0	0	0	R1
	↑	0	1	0	0	0	0	0	0	0	0	0	0	0	0	0	0	0	R2
	:	:	:	:	:	:	:	:	:	:	:	:	:	:	:	:	:	:	R3~R60
	:	:	:	:	:	:	:	:	:	:	:	:	:	:	:	:	:	:	
	↓	1	0	1	1	1	1	0	0	0	0	0	0	0	0	0	0	0	R61
	Light	0	1	1	1	1	1	0	0	0	0	0	0	0	0	0	0	0	R62
	Red	1	1	1	1	1	1	0	0	0	0	0	0	0	0	0	0	0	R63
Gray Scale Of Green	Black	0	0	0	0	0	0	0	0	0	0	0	0	0	0	0	0	0	G0
	Dark	0	0	0	0	0	0	1	0	0	0	0	0	0	0	0	0	0	G1
	↑	0	0	0	0	0	0	0	1	0	0	0	0	0	0	0	0	0	G2
	:	:	:	:	:	:	:	:	:	:	:	:	:	:	:	:	:	:	G3~G60
	:	:	:	:	:	:	:	:	:	:	:	:	:	:	:	:	:	:	
	↓	0	0	0	0	0	0	1	0	1	1	1	1	0	0	0	0	0	G61
	Light	0	0	0	0	0	0	0	1	1	1	1	1	0	0	0	0	0	G62
	Green	0	0	0	0	0	0	1	1	1	1	1	1	0	0	0	0	0	G63
Gray Scale Of Blue	Black	0	0	0	0	0	0	0	0	0	0	0	0	0	0	0	0	0	B0
	Dark	0	0	0	0	0	0	0	0	0	0	0	0	1	0	0	0	0	B1
	↑	0	0	0	0	0	0	0	0	0	0	0	0	0	1	0	0	0	B2
	:	:	:	:	:	:	:	:	:	:	:	:	:	:	:	:	:	:	B3~B60
	:	:	:	:	:	:	:	:	:	:	:	:	:	:	:	:	:	:	
	↓	0	0	0	0	0	0	0	0	0	0	0	0	1	0	1	1	1	B61
	Light	0	0	0	0	0	0	0	0	0	0	0	0	0	1	1	1	1	B62
	Blue	0	0	0	0	0	0	0	0	0	0	0	0	1	1	1	1	1	B63

Note 1) Definition of gray :

Rn: Red gray, Gn: Green gray, Bn: Blue gray (n=gray level)

Note 2) Input signal: 0 =Low level voltage, 1=High level voltage

Samsung Secret

Preliminary

5.6 Pixel Format in the display

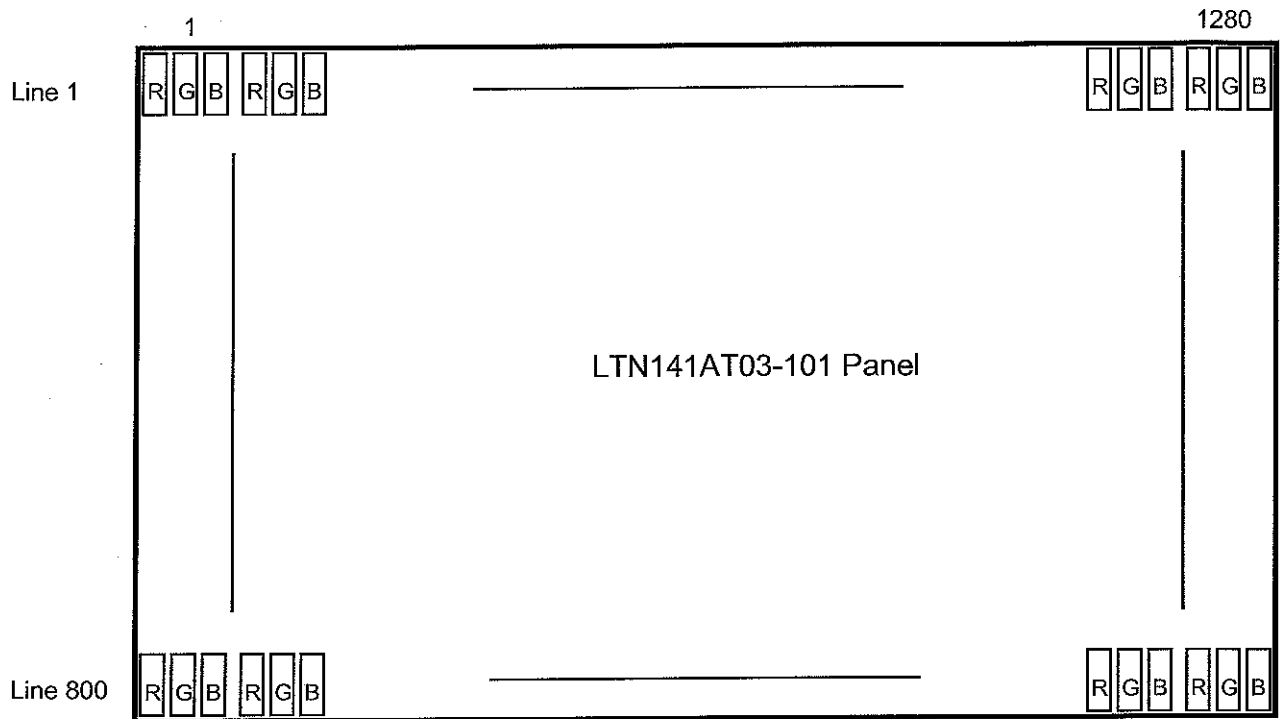

Samsung Secret

Preliminary

6. INTERFACE TIMING

6.1 Timing Parameters

Signal	Item	Symbol	Min.	Typ.	Max.	Unit	Note
Frame Frequency	Cycle	TV	(804)	(816)	(833)	Lines	
Vertical Active Display Term	Display Period	TVD	-	(800)	-	Lines	
One Line Scanning Time	Cycle	TH	(1316)	(1408)	(1500)	Clocks	
Horizontal Active Display Term	Display Period	THD	-	(1280)	-	Clocks	

6.2 Timing diagrams of interface signal

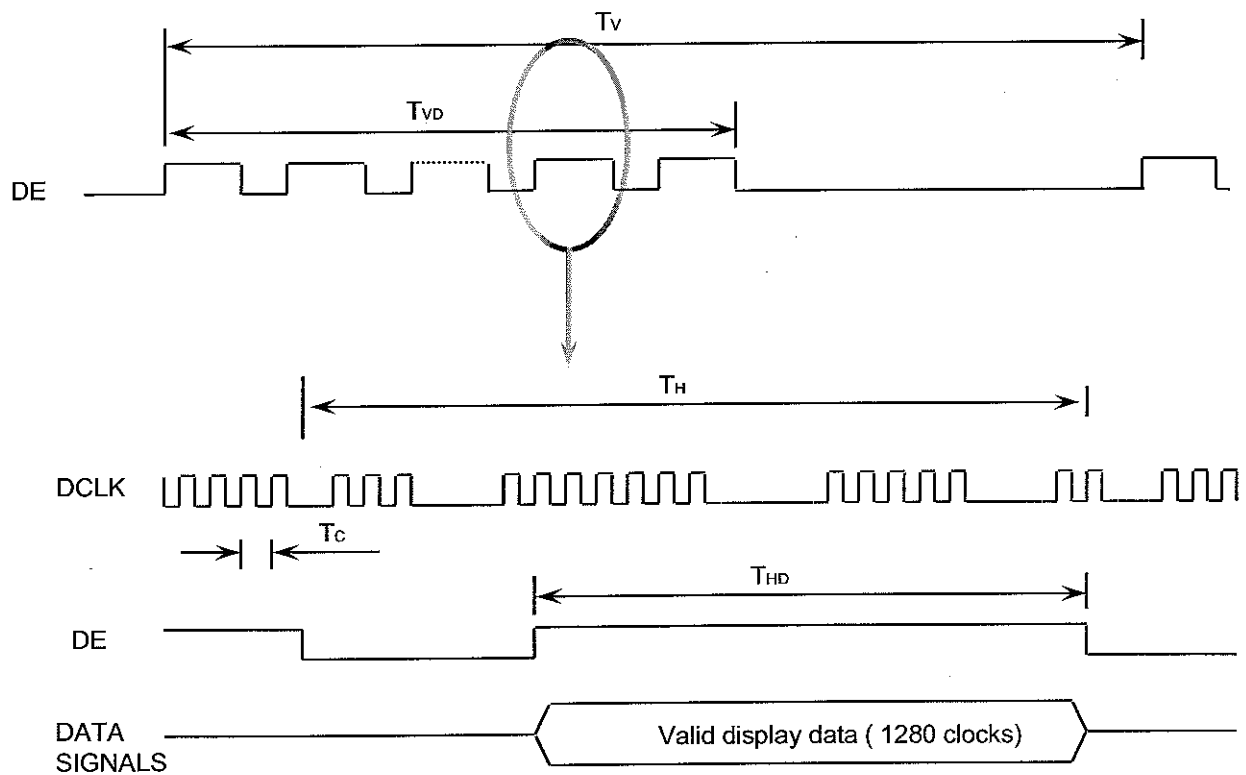

Samsung Secret

Preliminary

6.3 Power ON/OFF Sequence

: To prevent a latch-up or DC operation of the LCD module, the power on/off sequence should be as the diagram below.

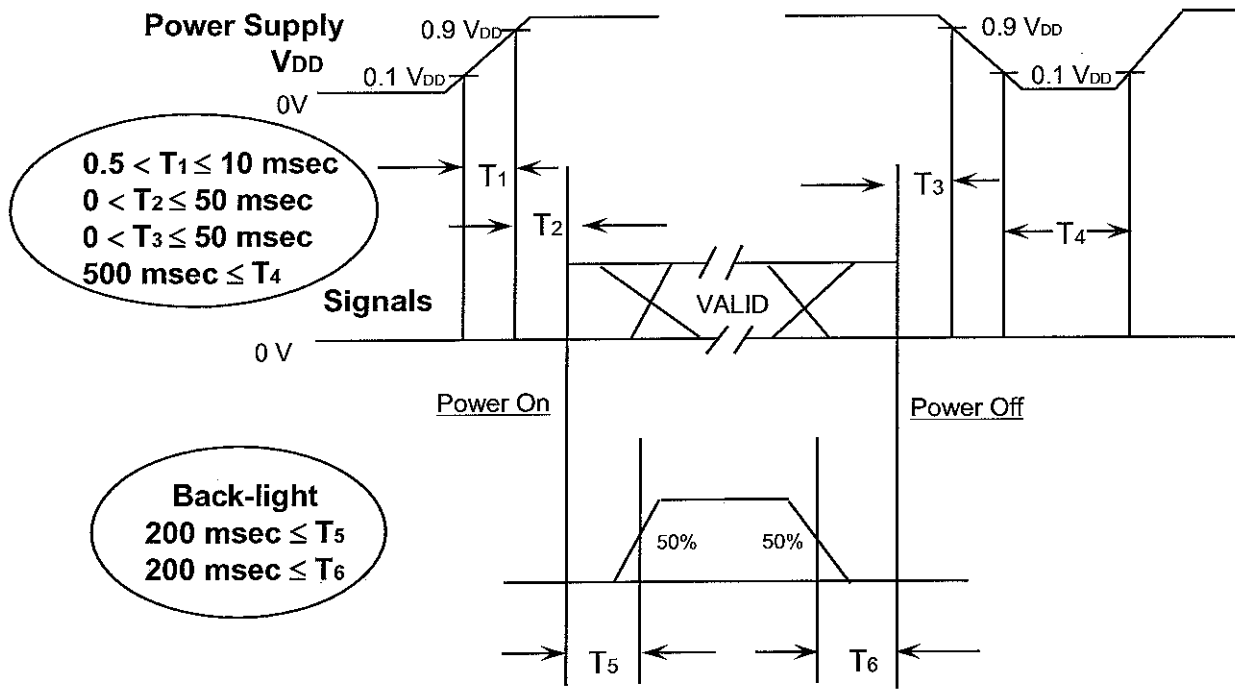

Power ON/OFF Sequence

- T1 : Vdd rising time from 10% to 90%
- T2 : The time from Vdd to valid data at power ON.
- T3 : The time from valid data off to Vdd off at power Off.
- T4 : Vdd off time for Windows restart
- T5 : The time from valid data to B/L enable at power ON.
- T6 : The time from valid data off to B/L disable at power Off.

NOTE.

- (1) The supply voltage of the external system for the module input should be the same as the definition of V_{DD}.
- (2) Apply the lamp voltage within the LCD operation range. When the back-light turns on before the LCD operation or the LCD turns off before the back-light turns off, the display may momentarily become white.
- (3) In case of V_{DD} = off level, please keep the level of input signals on the low or keep a high impedance.
- (4) T₄ should be measured after the module has been fully discharged between power off and on period.
- (5) Interface signal shall not be kept at high impedance when the power is on.

Samsung Secret

7. Mechanical Outline Dimension

Preliminary

Refer to the next page

Samsung Secret

Doc.No.	LTN141AT03-101	Rev.No	04-P00-G-070601	Page	21 / 27
---------	----------------	--------	-----------------	------	---------

REV	PART NAME	DATE	NO.	SPECIFICATION	REVISED BY
1	UNIVERSAL-201	02/01/00	001	UNIVERSAL-201	UNIVERSAL-201

SCREEN PENETRATION DEPTH

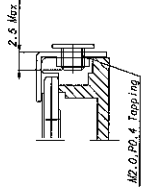

SECTION A-A' (S=6/1)

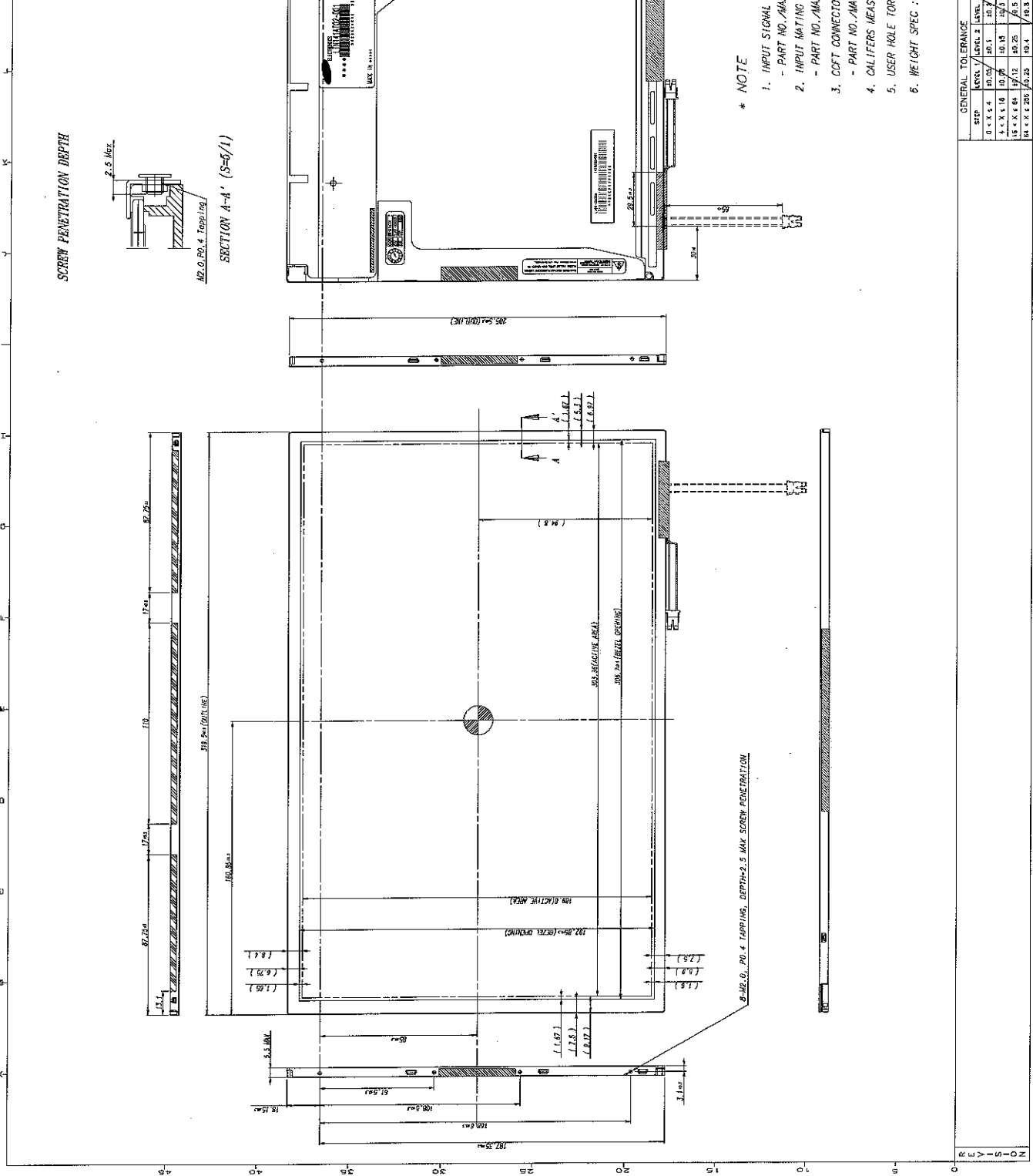

* NOTE

- INPUT SIGNAL INTERFACE CONNECTOR TO BE SPECIFIED AS BELOW.
- PART NO./MAKER : FI-XB30SL-HF10/JAE (or compatible)
- INPUT MATING SIGNAL INTERFACE CONNECTOR TO BE SPECIFIED AS BELOW.
- PART NO./MAKER : FI-X30M/JAE (or compatible)
- COFT CONNECTOR FOR BACKLIGHT TO BE SPECIFIED AS BELOW.
- PART NO./MAKER : BHSR-02/IS-T/JST (or compatible)
- CALIFERS MEASURING FORCE : 530 ± 150 gf
- USER HOLE TORQUE SPEC : 2.5kg/cm MAX (5 TIMES)
- WEIGHT SPEC : 4.30g MAX

GENERAL TOLERANCE		DESIGNATION OF SURFACE FINISH		REASON	
STEP	LEVEL	LEVEL 2	LEVEL 3	MATERIAL	TYPE
0 < X < 4	10.00	10.1	10.2	10.3	10.4
4 < X < 16	10.00	10.15	10.2	10.3	10.4
16 < X < 64	10.00	10.25	10.3	10.4	10.5
64 < X < 256	10.25	10.4	10.5	10.6	10.7

REV	DATE	NO.	DESCRIPTION
1	02/01/00	001	UNIVERSAL-201

REV	DATE	NO.	DESCRIPTION
1	02/01/00	001	UNIVERSAL-201

REV	DATE	NO.	DESCRIPTION
1	02/01/00	001	UNIVERSAL-201

8. GENERAL PRECAUTIONS

Preliminary

1. Handling

- (a) When the module is assembled, It should be attached to the system firmly using every mounting holes. Be careful not to twist and bend the modules.
- (b) Refrain from strong mechanical shock and / or any force to the module. In addition to damage, this may cause improper operation or damage to the module and CCFT back-light.
- (c) Note that polarizers are very fragile and could be easily damaged. Do not press or scratch the surface harder than a HB pencil lead.
- (d) Wipe off water droplets or oil immediately. If you leave the droplets for a long time, Staining and discoloration may occur.
- (e) If the surface of the polarizer is dirty, clean it using some absorbent cotton or soft cloth.
- (f) The desirable cleaners are water, IPA (Isopropyl Alcohol) or Hexane. Do not use Ketone type materials(ex. Acetone), Ethyl alcohol, Toluene, Ethyl acid or Methyl chloride. It might permanent damage to the polarizer due to chemical reaction.
- (g) If the liquid crystal material leaks from the panel, it should be kept away from the eyes or mouth . In case of contact with hands, legs or clothes, it must be washed away thoroughly with soap.
- (h) Protect the module from static , it may cause damage to the C-MOS Gate Array IC.
- (i) Use fingerstalls with soft gloves in order to keep display clean during the incoming inspection and assembly process.
- (j) Do not disassemble the module.
- (k) Do not pull or fold the lamp wire.
- (l) Do not adjust the variable resistor which is located on the back side.
- (m) Protection film for polarizer on the module shall be slowly peeled off just before use so that the electrostatic charge can be minimized.
- (n) Pins of I/F connector shall not be touched directly with bare hands.

Samsung Secret

Doc.No.	LTN141AT03-101	Rev.No	04-P00-G-070601	Page	23 / 27
---------	----------------	--------	-----------------	------	---------

Preliminary

2. STORAGE

- (a) Do not leave the module in high temperature, and high humidity for a long time.
It is highly recommended to store the module with temperature from 0 to 35 °C and relative humidity of less than 70%.
- (b) Do not store the TFT-LCD module in direct sunlight.
- (c) The module shall be stored in a dark place. It is prohibited to apply sunlight or fluorescent light during the store.

3. OPERATION

- (a) Do not connect,disconnect the module in the " Power On" condition.
- (b) Power supply should always be turned on/off by following item 6.3 " Power on/off sequence ".
- (c) Module has high frequency circuits. Sufficient suppression to the electromagnetic interference shall be done by system manufacturers. Grounding and shielding methods may be important to minimize the interference.
- (d) The cable between the back-light connector and its inverter power supply shall be a minimized length and be connected directly . The longer cable between the back-light and the inverter may cause lower luminance of lamp(CCFT) and may require higher startup voltage (Vs).
- (e) The standard limited warranty is only applicable when the module is used for general notebook applications. If used for purposes other than as specified, SEC is not to be held reliable for the defective operations. It is strongly recommended to contact SEC to find out fitness for a particular purpose.

4. OTHERS

- (a) Ultra-violet ray filter is necessary for outdoor operation.
- (b) Avoid condensation of water. It may result in improper operation or disconnection of electrode.
- (c) Do not exceed the absolute maximum rating value. (the supply voltage variation, input voltage variation, variation in part contents and environmental temperature, so on)
Otherwise the module may be damaged.
- (d) If the module displays the same pattern continuously for a long period of time,it can be the situation when the image "sticks" to the screen.
- (e) This module has its circuitry PCB's on the rear side and should be handled carefully in order not to be stressed.

Samsung Secret

Doc.No.	LTN141AT03-101	Rev.No	04-P00-G-070601	Page	24 / 27
---------	----------------	--------	-----------------	------	---------

9. EDID

Preliminary

Address (HEX)	FUNCTION	Value	BIN	DEC	ASCII or Data	Notes
		HEX				
00	Header	00	00000000	0		EDID Header
01		FF	11111111	255		
02		FF	11111111	255		
03		FF	11111111	255		
04		FF	11111111	255		
05		FF	11111111	255		
06		FF	11111111	255		
07		00	00000000	0		
08	ID Manufacturer Name	4C	01001100	76	S	3 character ID
09		A3	10100011	163	E C	"SEC"
0A	ID Product Code	42	01000010	66	[B]	
0B		48	01001000	72	[H]	
0C	32-bit serial no.	00	00000000	0		
0D		00	00000000	0		
0E		00	00000000	0		
0F		00	00000000	0		
10	Week of manufacture	00	00000000	0		
11	Year of manufacture	11	00010001	17	2007	2007
12	EDID Structure Ver.	01	00000001	1	1	EDID Ver. 1.0
13	EDID revision #	03	00000011	3	3	EDID Rev. 3
14	Video input definition	80	10000000	128		
15	Max H image size	1E	00011110	30	30	30 cm(approx)
16	Max V image size	13	00010011	19	19	19 cm(approx)
17	Display Gamma	78	01111000	120	2.2	Gamma 2.2
18	Feature support	0A	00001010	10		
19	Red/green low bits	87	10000111	135		10000111
1A	Blue/white low bits	F5	11110101	245		11111110
1B	Red x high bits	94	10010100	148	0.580	Red x0.580= 1001010010
1C	Red y	57	01010111	87	0.340	Red y0.340= 0101011100
1D	Green x	4F	01001111	79	0.310	Green x0.310= 0100111101
1E	Green y	8C	10001100	140	0.550	Green y0.550= 1000110011
1F	Blue x	27	00100111	39	0.155	Blue x0.155= 0010011111
20	Blue y	27	00100111	39	0.155	Blue y0.155= 0010011111
21	White x	50	01010000	80	0.313	White x0.313= 0101000001
22	White y	54	01010100	84	0.329	White y0.329= 0101010001
23	Established timing 1	00	00000000	0		
24	Established timing 2	00	00000000	0		
25	Established timing 3	00	00000000	0		

Samsung Secret

Preliminary

26	Standard timing #1	01	00000001	1		not used	
27		01	00000001	1			
28	Standard timing #2	01	00000001	1		not used	
29		01	00000001	1			
2A	Standard timing #3	01	00000001	1		not used	
2B		01	00000001	1			
2C	Standard timing #4	01	00000001	1		not used	
2D		01	00000001	1			
2E	Standard timing #5	01	00000001	1		not used	
2F		01	00000001	1			
30	Standard timing #6	01	00000001	1		not used	
31		01	00000001	1			
32	Standard timing #7	01	00000001	1		not used	
33		01	00000001	1			
34	Standard timing #8	01	00000001	1		not used	
35		01	00000001	1			
36	Detailed timing/monitor descriptor #1	EE	11101110	238	68.94	Main clock= 68.94 MHz	
37		1A	00011010	26			
38		00	00000000	0	1280	Hor active=640*2 pixels	
39		80	10000000	128	128	Hor blanking=128 pixels	
3A		50	01010000	80		4bit : 4bit	
3B		20	00100000	32	800	Vertical active=800 lines	
3C		10	00010000	16	16	Vertical blanking=16 lines	
3D		30	00110000	48		4bit : 4bit	
3E		0C	00001100	12	12	Hor sync. Offset=12 pixels	
3F		40	01000000	64	64	H sync. Width=64 pixels	
40			33	00110011	51	3 3	V sync. Offset=3 lines V sync. Width=3 lines
41			00	00000000	0		2bit : 2bit :2bit :2bit
42			2F	00101111	47	303	H image size= 303 mm(approx)
43			BE	10111110	190	190	V image size = 190 mm(approx)
44		10	00010000	16			
45		00	00000000	0		No Horizontal Border	
46		00	00000000	0		No Vertical Border	
47		19	00011001	25			
48	Detailed timing/monitor descriptor #2	00	00000000	0		Manufacturer Specified (Timing)	
49		00	00000000	0			
4A		00	00000000	0			
4B		0F	00001111	15			
4C		00	00000000	0			
4D		00	00000000	..		Value=HSPWmin / 2	
4E		00	00000000	..		Value=HSPWmax / 2	
4F		00	00000000	..		Value=Thbpmmin / 2	
50		00	00000000	..		Value=Thbpmmax / 2	
51		00	00000000	..		Value=VSPWmin / 2	
52		00	00000000	..		Value=VSPWmax / 2	
53		00	00000000	..		Value=Tvbpmin / 2	
54		00	00000000	..		Value=Tvbpmax / 2	
55		23	00100011		Thpmin=value*2 + HA pixelclks	
56	87	10000111		Thpmax=value*2 + HA pixelclks		
57	02	00000010	..		Tvpmin=value*2 + VA lines		
58	64	01100100		Tvpmax=value*2 + VA lines		
59		01	00000001	1		Module revision	

Samsung Secret