

**SAMSUNG****ELECTRONICS**

Approval

TO : LENOVO

DATE : April, 24, 2009

**SAMSUNG TFT-LCD****MODEL NO. : LTN141AT12-M01**

NOTE :

- Extension code [M01]
- Surface type [ Anti-Glare ]

*Any Modification of Specification is not allowed without SEC's Permission.*

APPROVED BY :

K. H. Shin

PREPARED BY : **Mobile division, Application Engineering Part****SAMSUNG ELECTRONICS CO., LTD.****Samsung Secret**

Doc.No.	LTN141AT12-M01	Rev.No	04-A03-S-090424	Page	1 / 29
---------	----------------	--------	-----------------	------	--------

**CONTENTS**

Approval

Revision History	----- ( 3 )
General Description	----- ( 4 )
1. Absolute Maximum Ratings	----- ( 5 )
1.1 Absolute Ratings of environment	
1.2 Electrical Absolute Ratings	
2. Optical Characteristics	----- ( 7 )
3. Electrical Characteristics	----- ( 10 )
3.1 TFT LCD Module	
3.2 Back-Light Unit	
3.3 LED Driver	
4. Block Diagram	----- ( 13 )
4.1 TFT LCD Module	
4.2 LED connection and placement	
5. Input Terminal Pin Assignment	----- ( 14 )
5.1 Input Signal & Power	
5.2 LVDS Interface	
5.3 Timing Diagrams of LVDS For Transmitting	
5.4 Input Signals, Basic Display Colors and Gray Scale of Each Color.	
5.5 Pixel format	
6. Interface Timing	----- ( 19 )
6.1 Timing Parameters	
6.2 Timing Diagrams of interface Signal	
6.3 Power ON/OFF Sequence	
7. Outline Dimension	----- ( 21 )
8. Product Markings and Others	----- ( 23 )
9. General Precautions	----- ( 24 )
10. EDID	----- ( 26 )

**Samsung Secret**

<b>Doc.No.</b>	LTN141AT12-M01	<b>Rev.No</b>	04-A03-S-090424	<b>Page</b>	2 / 29
----------------	----------------	---------------	-----------------	-------------	--------

## REVISION HISTORY

Approval

Date	Rev. No.	Page	Summary
April. 3, 2009	A00	All	- LTN141AT12-M01 approval specification was issued first.
April.15.2009	A01	-	- EDID was updated.
April.18.2009	A02	P4 P5 P13 P21 P23 P24	-With LED driver → without LED driver - Relative humidity value was updated(20% → 8%) - Block diagram (B/L portion) was updated - Power on/off sequence was updated - Outline drawing was updated( weight, LVDS connector name) - Product label was updated
April.24.2009	A03	P14 ,15 P23	- LVDS connector was updated.  - Outline drawing was updated ( label , tolerance)

**Samsung Secret**

<b>Doc.No.</b>	LTN141AT12-M01	<b>Rev.No</b>	04-A03-S-090424	<b>Page</b>	3 / 29
----------------	----------------	---------------	-----------------	-------------	--------

Approval

**GENERAL DESCRIPTION****DESCRIPTION**

LTN141AT12-M01 is a color active matrix TFT (Thin Film Transistor) liquid crystal display (LCD) that uses amorphous silicon TFT as a switching devices. This model is composed of a TFT LCD panel, a driver circuit and a backlight unit. The resolution of a 14.1" contains 1,280 x 800 pixels and can display up to 262,144 colors. 6 O'clock direction is the Optimum viewing angle.

**FEATURES**

- High contrast ratio, high aperture structure
- 1280 x 800 pixels resolution
- Low power consumption
- Fast Response
- LED BLU without LED driver
- DE (Data enable) only mode
- 3.3V LVDS Interface
- Onboard EEDID chip

**APPLICATIONS**

- Notebook PC
- If the usage of this product is not for PC application, but for others, please contact SEC.

**GENERAL INFORMATION**

Item	Specification	Unit	Note
Display area	303.36(H) x 189.6(V) (14.1" diagonal )	mm	
Driver element	a-Si TFT active matrix		
Display colors	262,144		
Number of pixel	1280 x RGB(3) x 800	pixel	16 : 10
Pixel arrangement	RGB vertical stripe		
Pixel pitch	0.2370(H) x 0.2370(V) (TYP.)	mm	
Display Mode	Normally white		
Surface treatment	HAZE 25, HARD-COATING 3H		Anti Glare

**Samsung Secret**

<b>Doc.No.</b>	LTN141AT12-M01	<b>Rev.No</b>	04-A03-S-090424	<b>Page</b>	4 / 29
----------------	----------------	---------------	-----------------	-------------	--------

Approval

## Mechanical Information

Item		Min.	Typ.	Max.	Unit	Note
Module size	Horizontal (H)	319.0	319.5	320.0	mm	-
	Vertical (V)	205.0	205.5	206.0	mm	
	Depth (D) [With the Glass]	-	-	5.5	mm	-
Weight [With the protective glass]		-	400	420	g	-

## 1. ABSOLUTE MAXIMUM RATINGS

## 1.1 ENVIRONMENTAL ABSOLUTE RATINGS

Item	Symbol	Min.	Max.	Unit	Note
Storage temperate	TSTG	-20	60	°C	(1)
Operating temperate (Temperature of glass surface)	TOPR	0	50	°C	(1)
Shock ( non-operating )	Snop	-	240	G	(2),(4)
Vibration (non-operating)	Vnop	-	2.41	G	(3),(4)

Note (1) Temperature and relative humidity range are shown in the figure below.

95 % RH Max. ( $40\text{ }^{\circ}\text{C} \geq T_a$ )

Maximum wet - bulb temperature at  $39\text{ }^{\circ}\text{C}$  or less. ( $T_a > 40\text{ }^{\circ}\text{C}$ ) No condensation

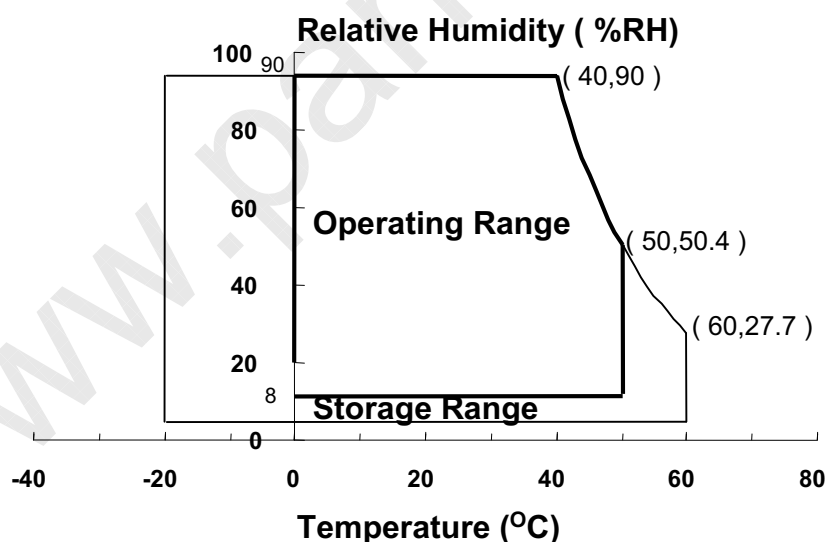

(2) 2ms, half sine wave, one time for  $\pm X, \pm Y, \pm Z$ .

(3) 5 - 500 Hz, random vibration, 30min for X, Y, Z.

(4) At testing Vibration and Shock, the fixture in holding the Module to be tested have to be hard and rigid enough so that the Module would not be twisted or bent by the fixture.

Samsung Secret

Approval

## 1.2 ELECTRICAL ABSOLUTE RATINGS

## (1) TFT LCD MODULE

 $V_{DD} = 3.3V, V_{SS} = GND = 0V$ 

Item	Symbol	Min.	Max.	Unit	Note
Power Supply Voltage	$V_{DD}$	$V_{SS} - 0.3$	3.6	V	(1)

Note (1) Within  $T_a$  ( $25 \pm 2 \text{ }^\circ\text{C}$ )

## (2) BACK-LIGHT UNIT

 $T_a = 25 \pm 2 \text{ }^\circ\text{C}$ 

Item	Symbol	Min.	Typ.	Max.	Unit	Note
LED Current	$I_L$	-	20	-	mArms	(1)
LED Voltage	$V_L$	-	3.3	-	V	(1)

Note 1) Permanent damage to the device may occur if maximum values are exceeded

Functional operation should be restricted to the conditions described under normal operating conditions.

Samsung Secret

Approval

## 2. OPTICAL CHARACTERISTICS

The following items are measured under stable conditions. The optical characteristics should be measured in a dark room or equivalent state with the methods shown in Note (5).  
Measuring equipment : TOPCON BM-5A and PR-650

\* Ta = 25 ± 2 °C, V<sub>DD</sub>=3.3V, f<sub>V</sub>= 60Hz, f<sub>DCLK</sub> = 76.77MHz, I<sub>L</sub> = 17 mArms

Item	Symbol	Condition	Min.	Typ.	Max	Unit	Note
Contrast Ratio (5 Points)	CR		200	300	-	-	(1), (2), (5)
Response Time at Ta ( Rising + Falling )	T <sub>RT,BW</sub>		-	16	25	msec	(1), (3)
Average Luminance of White (5 Points)	Y <sub>L,AVE</sub>		190	220	-	cd/m <sup>2</sup>	I <sub>L</sub> =17mA (1), (4)
Color Chromaticity ( CIE )	Red	R <sub>X</sub>	0.550	0.580	0.610	-	(1), (5) PR-650
		R <sub>Y</sub>	0.310	0.340	0.370		
	Green	G <sub>X</sub>	0.315	0.345	0.375		
		G <sub>Y</sub>	0.520	0.550	0.580		
	Blue	B <sub>X</sub>	0.121	0.151	0.181		
		B <sub>Y</sub>	0.070	0.100	0.130		
	White	W <sub>X</sub>	0.283	0.313	0.343		
		W <sub>Y</sub>	0.299	0.329	0.359		
Viewing Angle	Hor.	θ <sub>L</sub>	-	45	-	Degrees	(1), (5) BM-5A
		θ <sub>R</sub>	-	45	-		
	Ver.	φ <sub>H</sub>	-	15	-		
		φ <sub>L</sub>	-	35	-		
13 Points White Variation	δ <sub>L</sub>		60	-	-	%	(6)

Samsung Secret

Doc.No.

LTN141AT12-M01

Rev.No

04-A03-S-090424

Page

7 / 29

Approval

Note 1) Definition of Viewing Angle : Viewing angle range(  $10 \leq C/R$ ,  $100 \leq C/R$  )

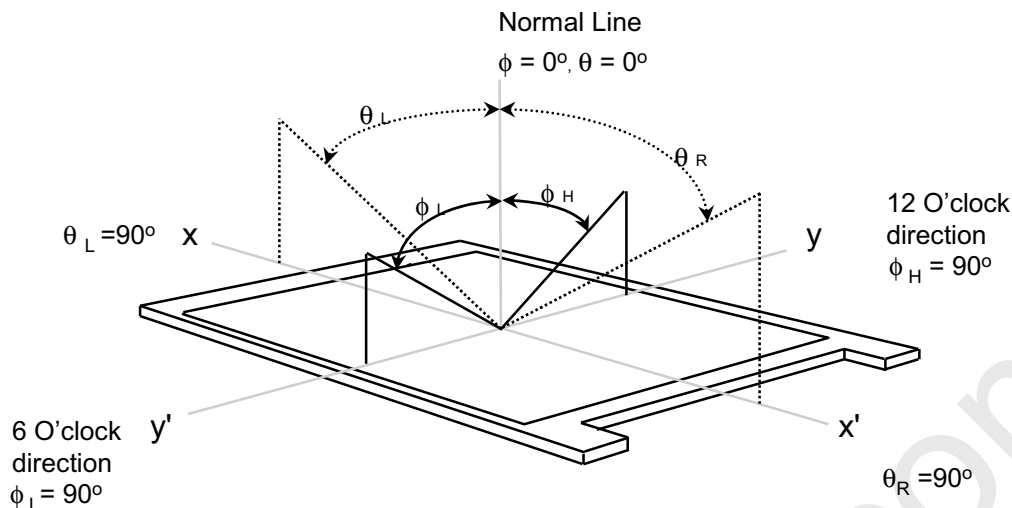

Note 2) Definition of Contrast Ratio (CR) : Ratio of gray max (Gmax) ,gray min (Gmin) at 5 points(4, 5, 7, 9, 10)

$$CR = \frac{CR(4) + CR(5) + CR(7) + CR(9) + CR(10)}{5}$$

Points : (4) , (5) , (7) , (9) , (10) at the figure of Note (6).

Note 3) Definition of Response time :

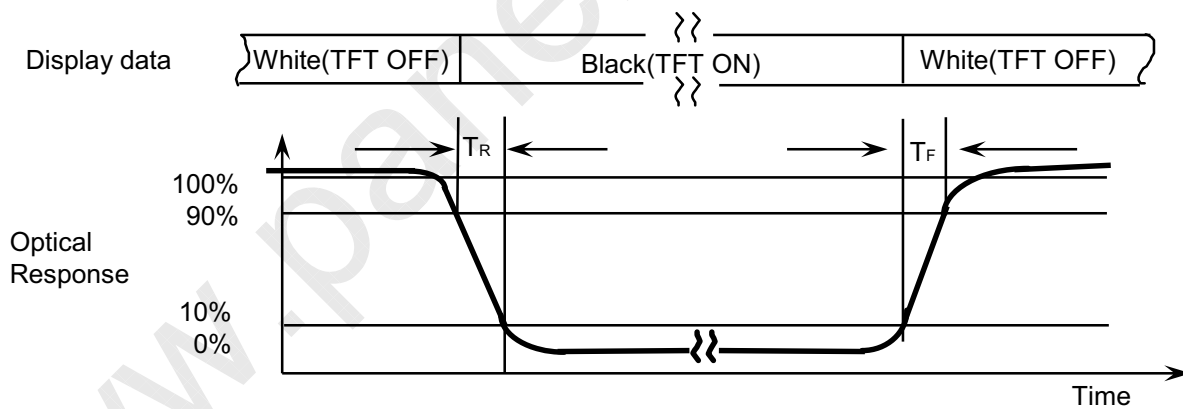

Note 4) Definition of Average Luminance of White : measure the luminance of white at 5 points.

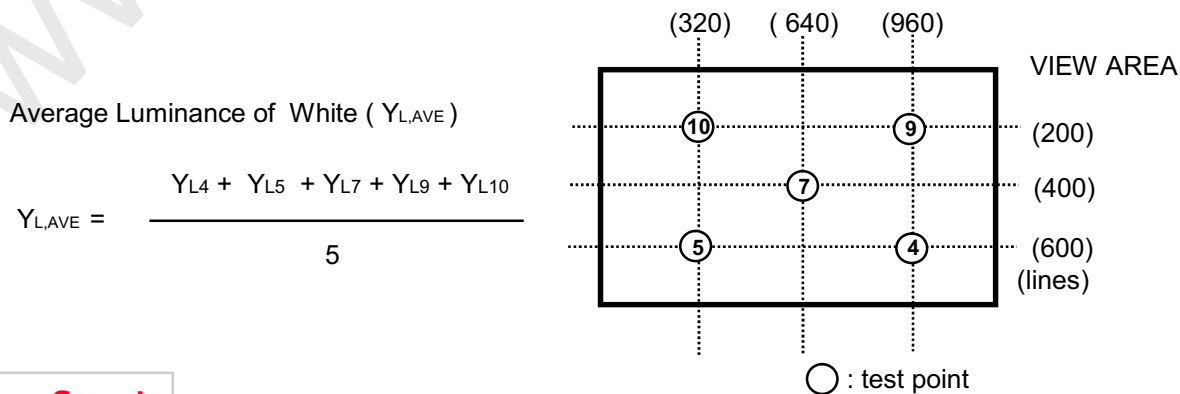

Samsung Secret



Approval

Note 5) After stabilizing and leaving the panel alone at a given temperature for 30 min , the measurement should be executed. Measurement should be executed in a stable, windless, and dark room. 30 min after lighting the backlight. This should be measured in the center of screen. Environment condition :  $T_a = 25 \pm 2 \text{ }^\circ\text{C}$

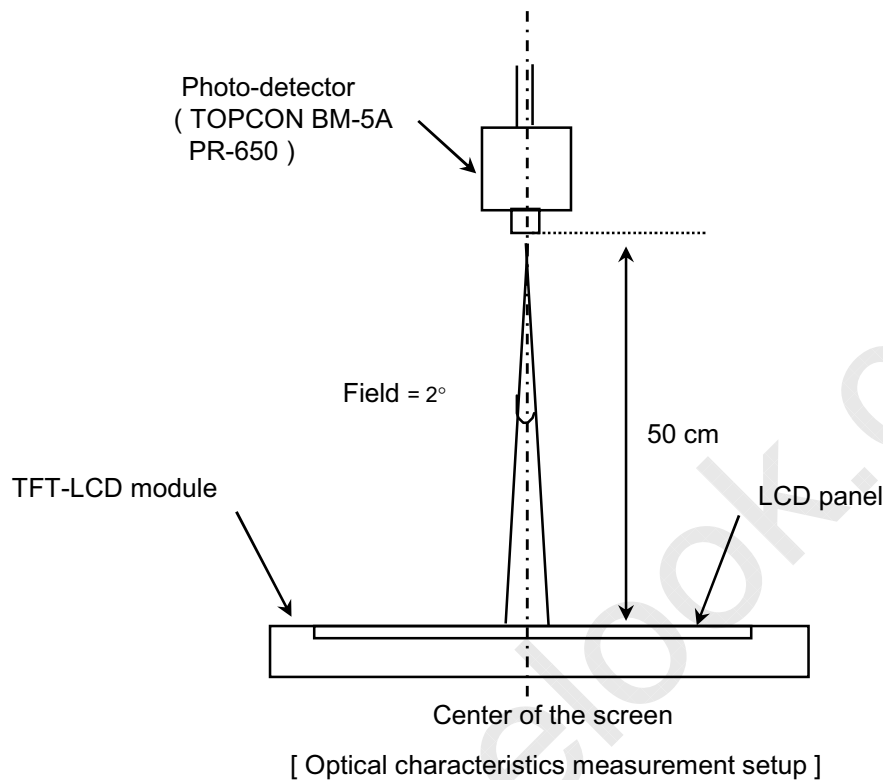

Note 6) Definition of 13 points white variation ( $\delta L$ ), CR variation( $C_{VER}$ ) [ ① ~ ⑬ ]

$$\delta L = \frac{\text{Maximum luminance of 13 points}}{\text{Minimum luminance of 13 points}}$$

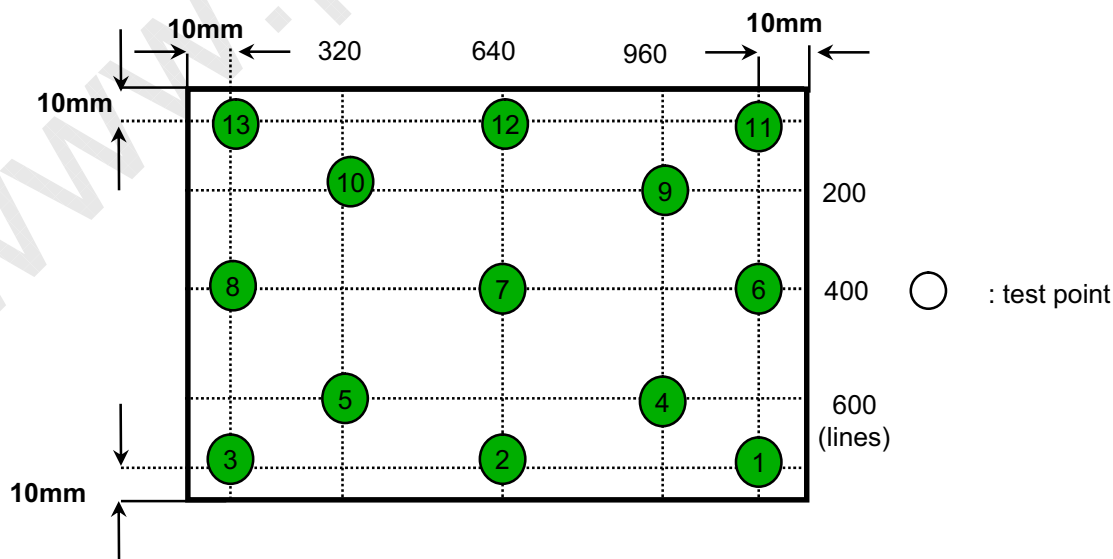

**Samsung Secret**

Doc.No.	LTN141AT12-M01	Rev.No	04-A03-S-090424	Page	9 / 29
---------	----------------	--------	-----------------	------	--------

### 3. ELECTRICAL CHARACTERISTICS

Approval

#### 3.1 TFT LCD MODULE

Ta= 25 ± 2°C

ITEM		SYMBOL	MIN	TYP	MAX	UNIT	NOTE	
Voltage of Power Supply		V <sub>DD</sub>	3.0	3.3	3.6	V		
Differential Input Voltage for LVDS Receiver Threshold		High	V <sub>IH</sub>	-	-	+100	mV	V <sub>CM</sub> =+1.2V
		Low	V <sub>IL</sub>	-100	-	-	mV	
Vsync Frequency	60Hz	Hsync Freq	F <sub>H</sub>	46.38	48.96	60	KHz	
		Main Freq	F <sub>DCLK</sub>	60.99	<b>82.06</b>	105	MHz	
	50Hz	Hsync Freq	F <sub>H</sub>	38.65	40.80	50	KHz	
		Main Freq	F <sub>DCLK</sub>	50.8	<b>57.05</b>	87.5	MHz	
	40Hz	Hsync Freq	F <sub>H</sub>	30.9	32.92	40	KHz	
		Main Freq	F <sub>DCLK</sub>	40.66	47.4	70	MHz	
Rush Current		I <sub>RUSH</sub>	-	-	1.5	A	(4)	
Current of Power Supply		White	I <sub>DD</sub>	-	260	-	mA	(2),(3)*a
		Mosaic		-	350	-	mA	(2),(3)*b
		WinXP Pattern		-	390	-	mA	(2),(3)*c
		Max Pattern		-	470	485	mA	(2),(3)*d

Note (1) Display data pins and timing signal pins should be connected.( GND = 0V )

(2) f<sub>V</sub> = 60Hz, f<sub>DCLK</sub> = 76.38MHz, V<sub>DD</sub> = 3.3V , DC Current.

(3) Power dissipation pattern

\*a) White Pattern



\*b) Mosaic Pattern

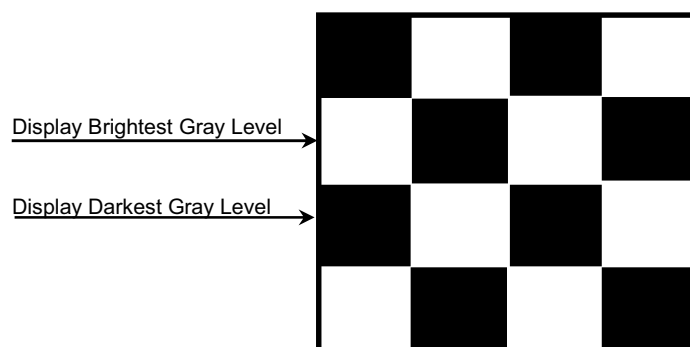

**Samsung Secret**

\*c) WinXP Pattern

Approval



\*d) 1dot Inversion Pattern

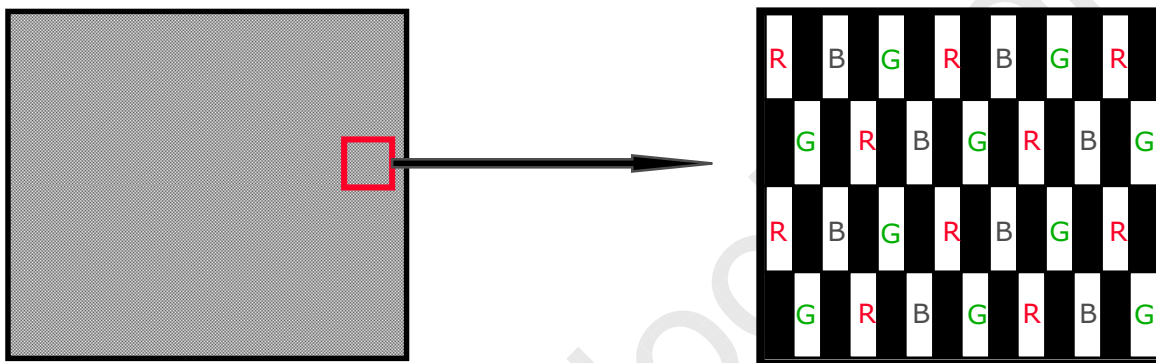

4) Rush current measurement condition

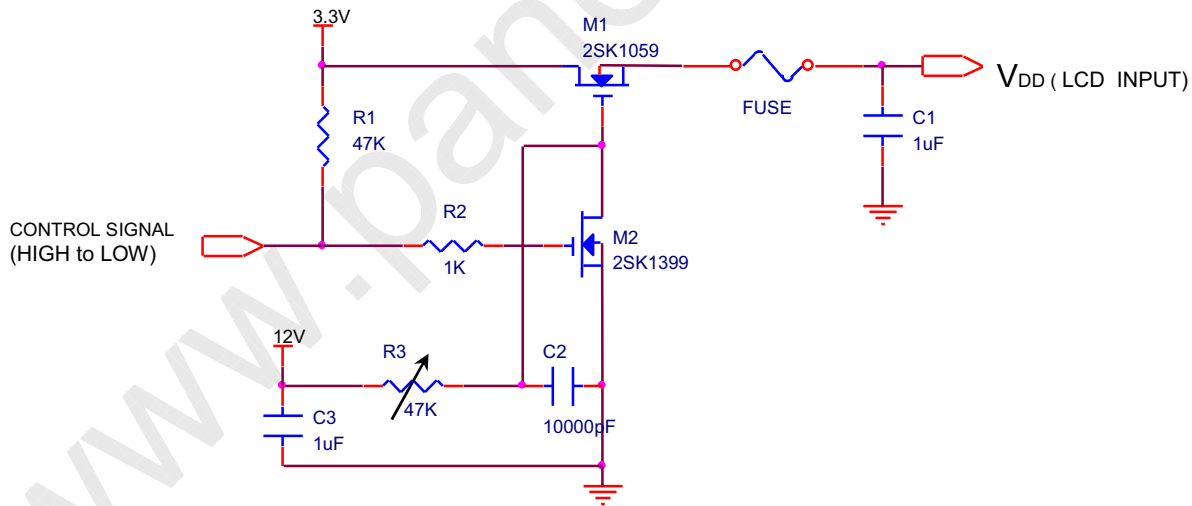

V<sub>DD</sub> rising time is 470us

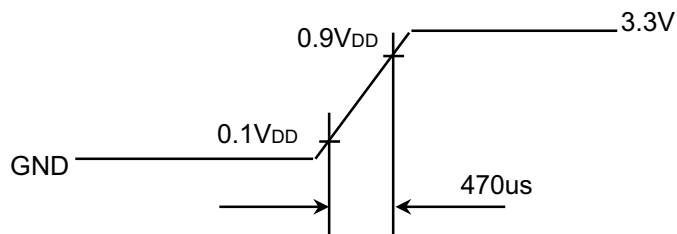

**Samsung Secret**

Doc.No.	LTN141AT12-M01	Rev.No	04-A03-S-090424	Page	11 / 29
---------	----------------	--------	-----------------	------	---------

Approval

## 3.2 Back-Light Unit

White LED chip P/N : 0601-002528

Item	Symbol	Min.	Typ.	Max.	Unit	Note
LED Forward Current	IF	-	20	-	mA	-
LED Forward Voltage	VF	-	3.3	-	V	-
LED Array Voltage	VP	-	23.1	-	V	VF X 7 LEDs
Power Consumption	P	-	3.2	-	W	IF X VF X 42LEDs
Operating Life Time	Hr	10,000	-	-	Hr	(1)

Samsung Secret

Doc.No.

LTN141AT12-M01

Rev.No

04-A03-S-090424

Page

12 / 29

Approval

### 4. BLOCK DIAGRAM

#### 4.1 TFT LCD Module

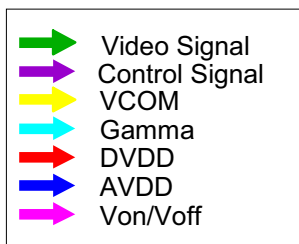
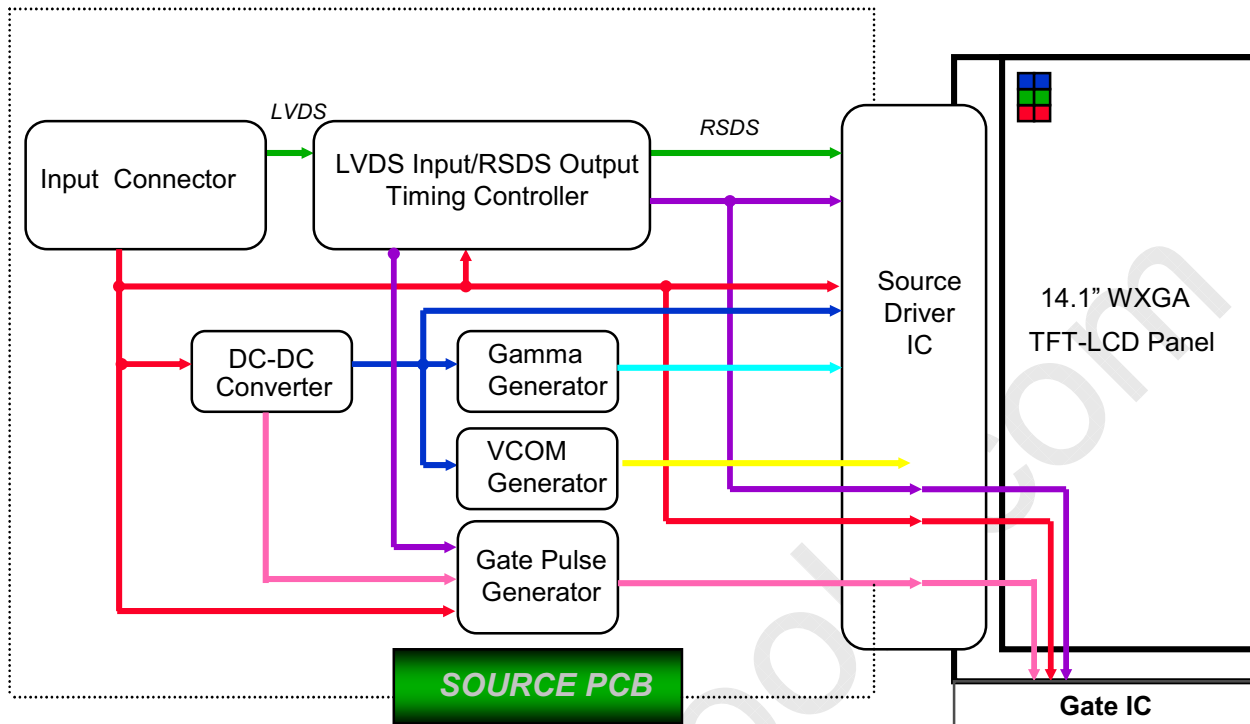

#### 4.2 LED placement structure

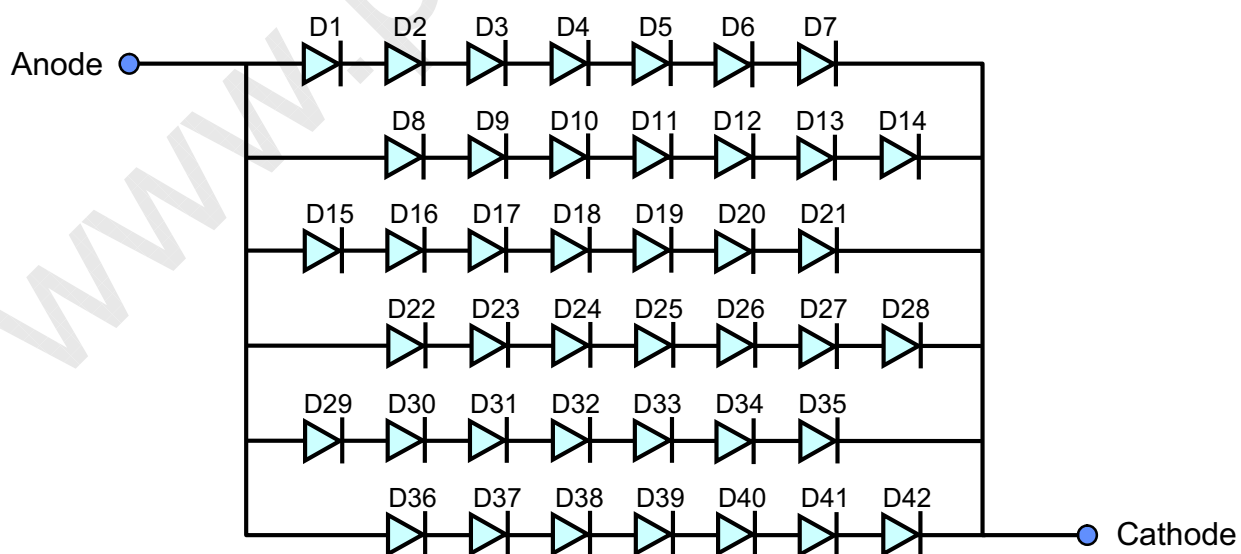

**Samsung Secret**

<b>Doc.No.</b>	LTN141AT12-M01	<b>Rev.No</b>	04-A03-S-090424	<b>Page</b>	13 / 29
----------------	----------------	---------------	-----------------	-------------	---------

Approval

## 5. INPUT TERMINAL PIN ASSIGNMENT

5.1. Input Signal & Power (LVDS, Connector : JAE FI-XB30SRLZ-HF11-SP  
 , UJU : IS100-L30R-C15  
 Mating Connector : JAE FI-X30M or compatible)

No.	Symbol	Function	Polarity	Remarks
1	VSS	Ground		
2	VDD	POWER SUPPLY +3.3V		
3	VDD	POWER SUPPLY +3.3V		
4	VEEDID	DDC 3.3V Power		
5	BIST	Panel BIST enable		
6	CLKEDID	DDC Clock		
7	DATAEDID	DDC data		
8	RxIN0-	LVDS Differential Data INPUT (R0-R5,G0)	Negative	
9	RxIN0+	LVDS Differential Data INPUT (R0-R5,G0)	Positive	
10	GND	Ground		
11	RxIN1-	LVDS Differential Data INPUT (G1-G5,B0-B1)	Negative	
12	RxIN1+	LVDS Differential Data INPUT (G1-G5,B0-B1)	Positive	
13	GND	Ground		
14	RxIN2-	LVDS Differential Data INPUT (B2-B5,Sync,DE)	Negative	
15	RxIN2+	LVDS Differential Data INPUT (B2-B5,Sync,DE)	Positive	
16	Vss	Ground		
17	CiKIN-	LVDS Differential Clock INPUT	Negative	
18	CiKIN+	LVDS Differential Clock INPUT	Positive	
19	Vss	Ground		
20	NC	No connect		
21	NC	No connect		
22	NC	No connect		
23	NC	No connect		
24	NC	No connect		
25	NC	No connect		
26	NC	No connect		
27	NC	No connect		
28	NC	No connect		
29	NC	No connect		
30	NC	No connect		

**Samsung Secret**

Approval

## 5.2 LVDS Interface : Transmitter DS90CF363 or Compatible

## LVDS

Pin No.	Name	RGB Signal	Pin No.	Name	RGB Signal
44	TxIN0	RO0	12	TxIN11	GO5
45	TxIN1	RO1	13	TxIN12	BO0
47	TxIN2	RO2	15	TxIN13	BO1
48	TxIN3	RO3	16	TxIN14	BO2
1	TxIN4	RO4	18	TxIN15	BO3
3	TxIN5	RO5	19	TxIN16	BO4
4	TxIN6	GO0	20	TxIN17	BO5
6	TxIN7	GO1	22	TxIN18	Hsync
7	TxIN8	GO2	23	TxIN19	Vsync
9	TxIN9	GO3	25	TxIN20	DE
10	TxIN10	GO4	26	TxCLK IN	Clock

## LVDS Interface

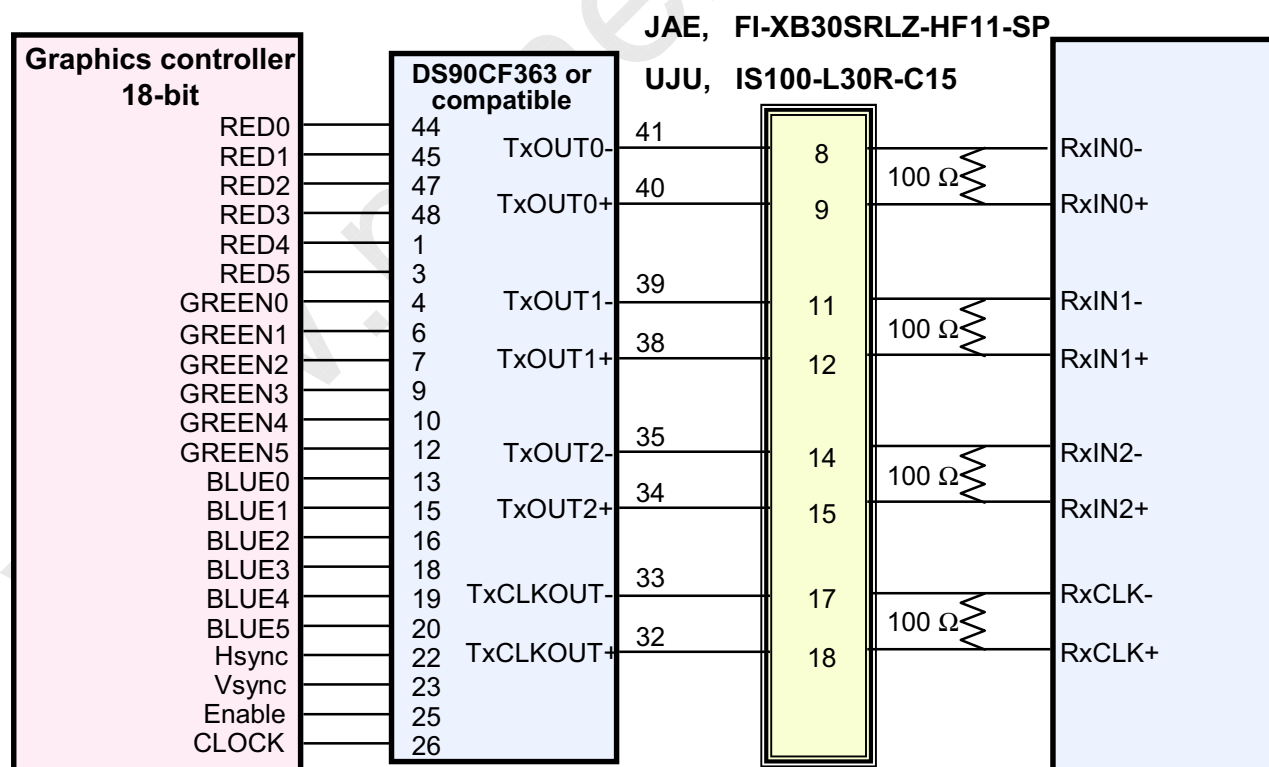

Note : The LCD Module uses a 100ohm resistor between positive and negative lines of each receiver input.

Samsung Secret

Doc.No.	LTN141AT12-M01	Rev.No	04-A03-S-090424	Page	15 / 29
---------	----------------	--------	-----------------	------	---------

Approval

## 5.3 Timing Diagrams of LVDS For Transmission

LVDS Receiver : Integrated T-CON

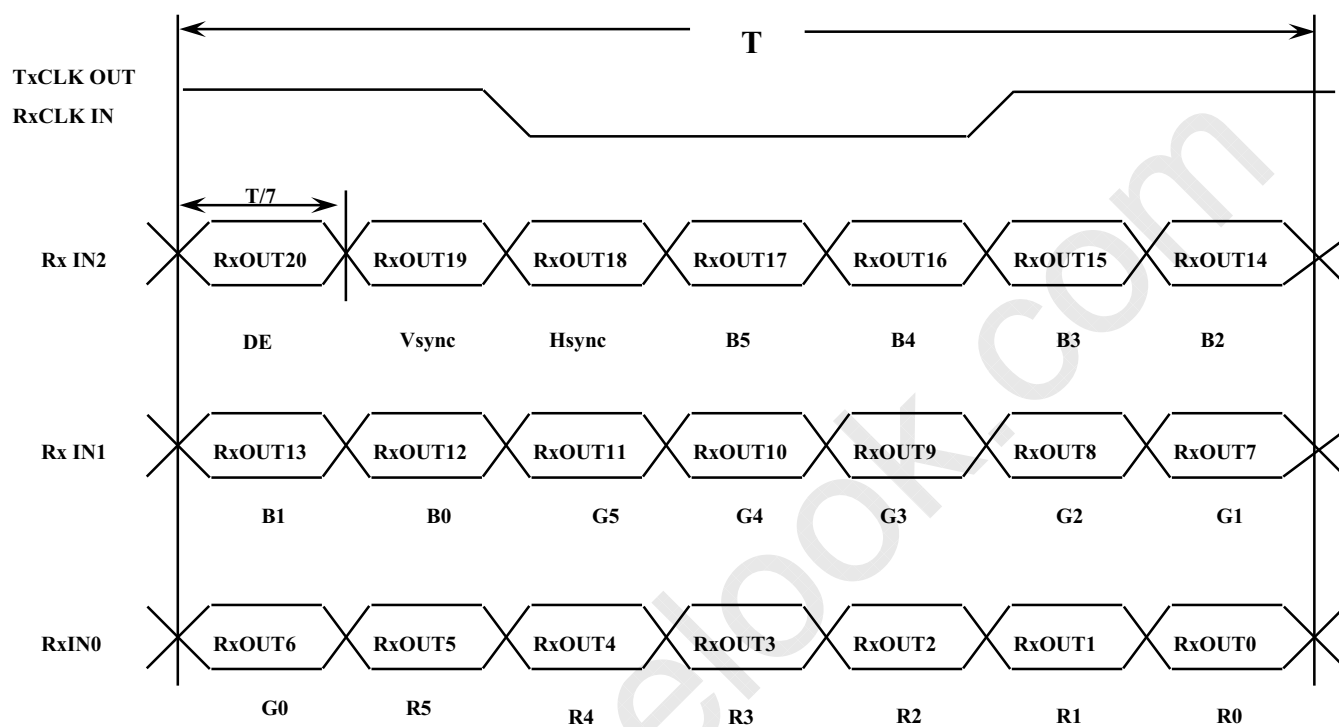

Samsung Secret

Doc.No.

LTN141AT12-M01

Rev.No

04-A03-S-090424

Page

16 / 29



Approval

### 5.4 Input Signals, Basic Display Colors and Gray Scale of Each Color

Color	Display	Data Signal																Gray Scale Level	
		Red					Green					Blue							
		R0	R1	R2	R3	R4	R5	G0	G1	G2	G3	G4	G5	B0	B1	B2	B3		45
Basic Colors	Black	0	0	0	0	0	0	0	0	0	0	0	0	0	0	0	0	0	-
	Blue	0	0	0	0	0	0	0	0	0	0	0	0	1	1	1	1	1	-
	Green	0	0	0	0	0	0	1	1	1	1	1	1	0	0	0	0	0	-
	Cyan	0	0	0	0	0	0	1	1	1	1	1	1	1	1	1	1	1	-
	Red	1	1	1	1	1	1	0	0	0	0	0	0	0	0	0	0	0	-
	Magenta	1	1	1	1	1	1	0	0	0	0	0	0	1	1	1	1	1	-
	Yellow	1	1	1	1	1	1	1	1	1	1	1	1	0	0	0	0	0	-
	White	1	1	1	1	1	1	1	1	1	1	1	1	1	1	1	1	1	-
Gray Scale Of Red	Black	0	0	0	0	0	0	0	0	0	0	0	0	0	0	0	0	0	R0
	Dark	1	0	0	0	0	0	0	0	0	0	0	0	0	0	0	0	0	R1
	↑	0	1	0	0	0	0	0	0	0	0	0	0	0	0	0	0	0	R2
	:	:	:	:	:	:	:	:	:	:	:	:	:	:	:	:	:	:	R3~R60
	:	:	:	:	:	:	:	:	:	:	:	:	:	:	:	:	:	:	
	↓	1	0	1	1	1	1	0	0	0	0	0	0	0	0	0	0	0	R61
	Light	0	1	1	1	1	1	0	0	0	0	0	0	0	0	0	0	0	R62
	Red	1	1	1	1	1	1	0	0	0	0	0	0	0	0	0	0	0	R63
Gray Scale Of Green	Black	0	0	0	0	0	0	0	0	0	0	0	0	0	0	0	0	0	G0
	Dark	0	0	0	0	0	0	1	0	0	0	0	0	0	0	0	0	0	G1
	↑	0	0	0	0	0	0	0	1	0	0	0	0	0	0	0	0	0	G2
	:	:	:	:	:	:	:	:	:	:	:	:	:	:	:	:	:	:	G3~G60
	:	:	:	:	:	:	:	:	:	:	:	:	:	:	:	:	:	:	
	↓	0	0	0	0	0	0	1	0	1	1	1	1	0	0	0	0	0	G61
	Light	0	0	0	0	0	0	0	1	1	1	1	1	0	0	0	0	0	G62
	Green	0	0	0	0	0	0	1	1	1	1	1	1	0	0	0	0	0	G63
Gray Scale Of Blue	Black	0	0	0	0	0	0	0	0	0	0	0	0	0	0	0	0	0	B0
	Dark	0	0	0	0	0	0	0	0	0	0	0	0	1	0	0	0	0	B1
	↑	0	0	0	0	0	0	0	0	0	0	0	0	0	1	0	0	0	B2
	:	:	:	:	:	:	:	:	:	:	:	:	:	:	:	:	:	:	B3~B60
	:	:	:	:	:	:	:	:	:	:	:	:	:	:	:	:	:	:	
	↓	0	0	0	0	0	0	0	0	0	0	0	0	1	0	1	1	1	B61
	Light	0	0	0	0	0	0	0	0	0	0	0	0	0	1	1	1	1	B62
	Blue	0	0	0	0	0	0	0	0	0	0	0	0	1	1	1	1	1	B63

Note 1) Definition of gray :

Rn: Red gray, Gn: Green gray, Bn: Blue gray (n=gray level)

Note 2) Input signal: 0 =Low level voltage, 1=High level voltage

Samsung Secret

Approval

5.5 Pixel Format in the display

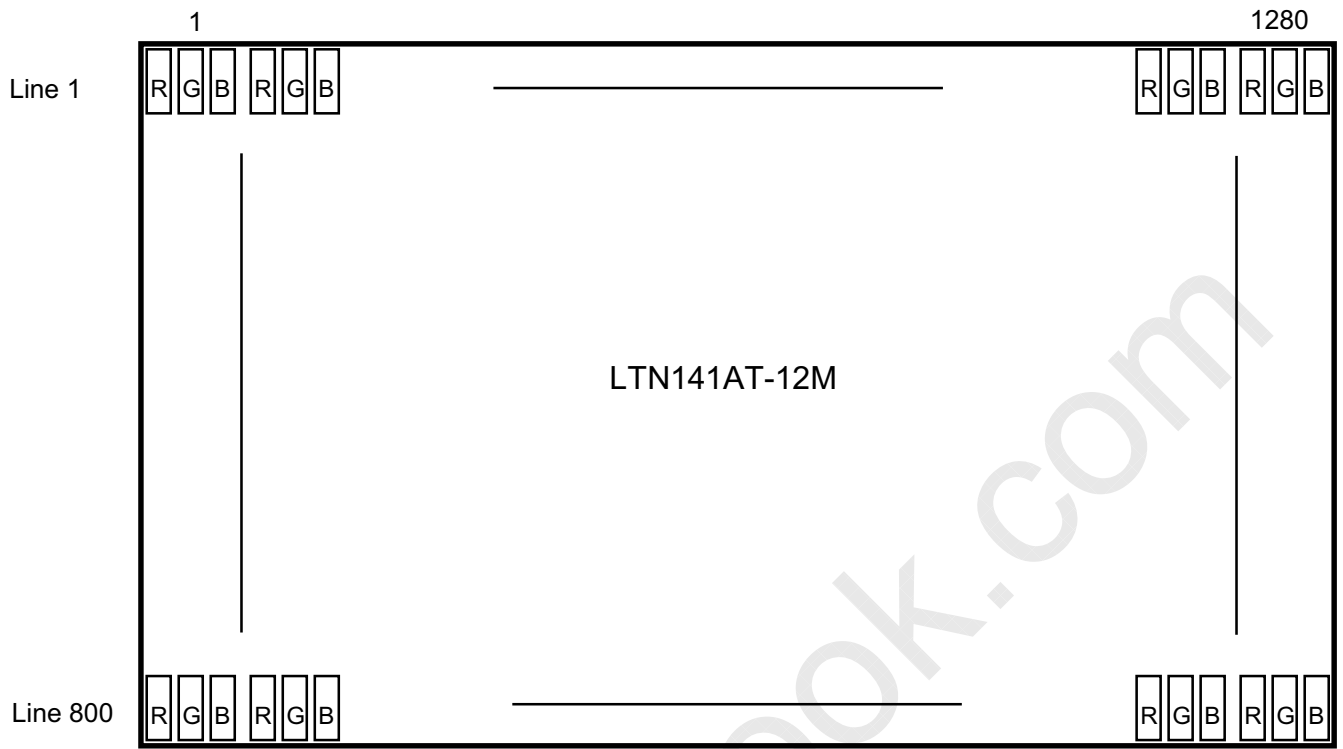

**Samsung Secret**

<b>Doc.No.</b>	LTN141AT12-M01	<b>Rev.No</b>	04-A03-S-090424	<b>Page</b>	18 / 29
----------------	----------------	---------------	-----------------	-------------	---------

Approval

## 5.6 LED FPC Connector &amp; Pin Assignment

LED FPC Connector : Tyco 1-179397-2

Pin #	Signal Name
1	LED Power (LED Anode)
2	LED Channel 1 Cathode
3	LED Power (LED Anode)
4	LED Channel 2 Cathode
5	LED Power (LED Anode)
6	LED Channel 3 Cathode
7	NC
8	LED Channel 4 Cathode
9	NC
10	LED Channel 5 Cathode
11	NC
12	LED Channel 6 Cathode

Samsung Secret

Doc.No.

LTN141AT12-M01

Rev.No

04-A03-S-090424

Page

19 / 29

Approval

## 6. INTERFACE TIMING

### 6.1 Timing Parameters

Signal	Item	Symbol	Min.	Typ.	Max.	Unit	Note
Frame Frequency	Cycle	$T_V$	806	816	833	Lines	
Vertical Active Display Term	Display Period	$T_{VD}$	-	800	-	Lines	
One Line Scanning Time	Cycle	$T_H$	1320	1408	1650	Clocks	
Horizontal Active Display Term	Display Period	$T_{HD}$	-	1280	-	Clocks	

### 6.2 Timing diagrams of interface signal

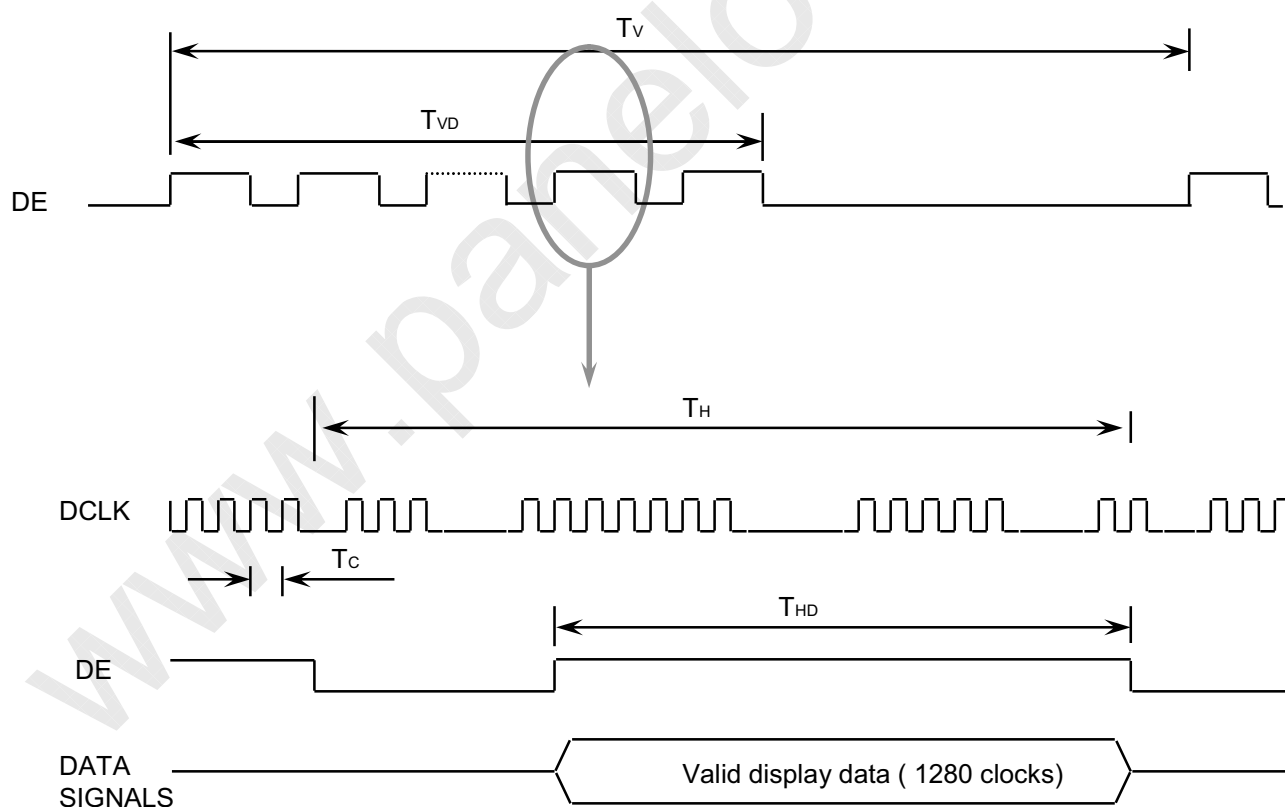

**Samsung Secret**

Doc.No.

LTN141AT12-M01

Rev.No

04-A03-S-090424

Page

20 / 29

## 6.3 Power ON/OFF Sequence

Approval

: To prevent a latch-up or DC operation of the LCD module, the power on/off sequence should be as the diagram below.

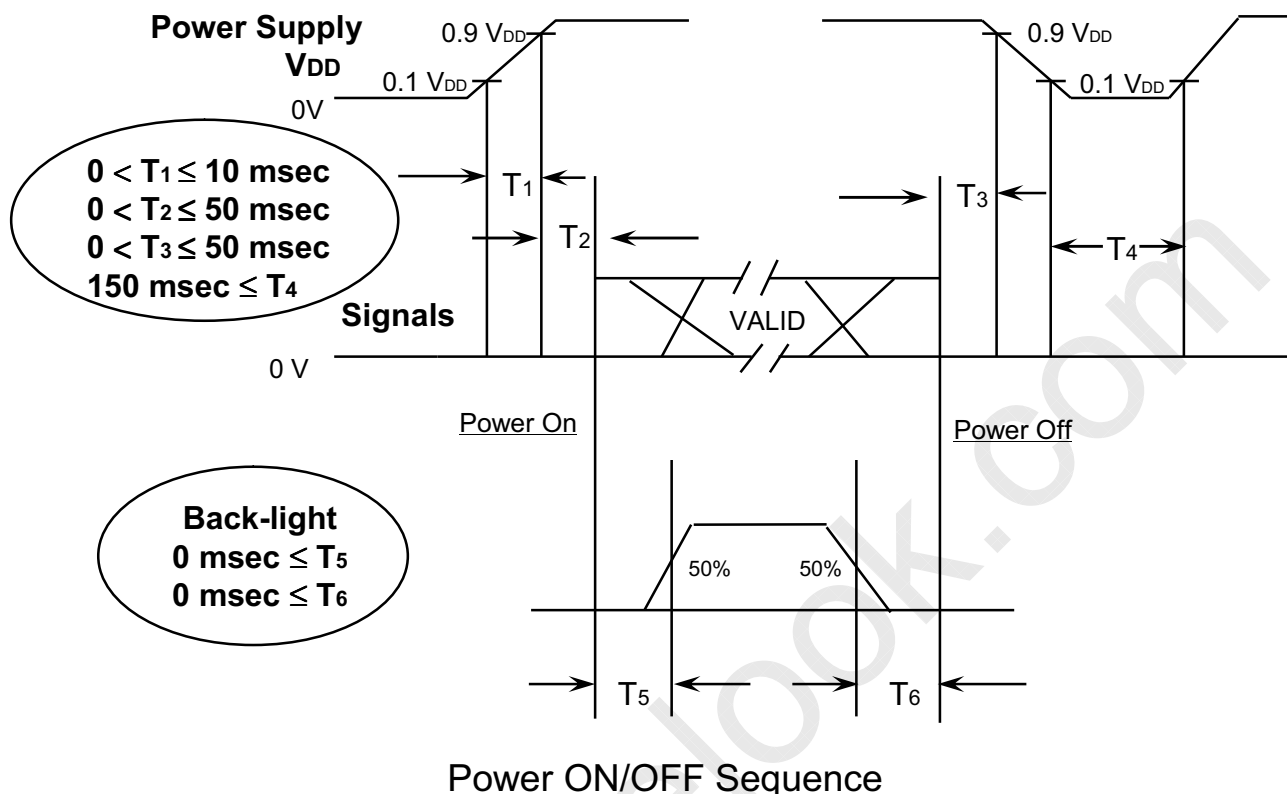

- T1 : Vdd rising time from 10% to 90%
- T2 : The time from Vdd to valid data at power ON.
- T3 : The time from valid data off to Vdd off at power Off.
- T4 : Vdd off time for Windows restart
- T5 : The time from valid data to B/L enable at power ON.
- T6 : The time from valid data off to B/L disable at power Off.

## NOTE.

- (1) The supply voltage of the external system for the module input should be the same as the definition of VDD.
- (2) Apply the lamp voltage within the LCD operation range. When the back-light turns on before the LCD operation or the LCD turns off before the back-light turns off, the display may momentarily become white.
- (3) In case of VDD = off level, please keep the level of input signals on the low or keep a high impedance.
- (4) T4 should be measured after the module has been fully discharged between power off and on period.
- (5) Interface signal shall not be kept at high impedance when the power is on.

Samsung Secret

Doc.No.	LTN141AT12-M01	Rev.No	04-A03-S-090424	Page	21 / 29
---------	----------------	--------	-----------------	------	---------



### 7. Mechanical Outline Dimension

Approval

It will be attached with PDF file

www.panelook.com

**Samsung Secret**

<b>Doc.No.</b>	LTN141AT12-M01	<b>Rev.No</b>	04-A03-S-090424	<b>Page</b>	22 / 29
----------------	----------------	---------------	-----------------	-------------	---------

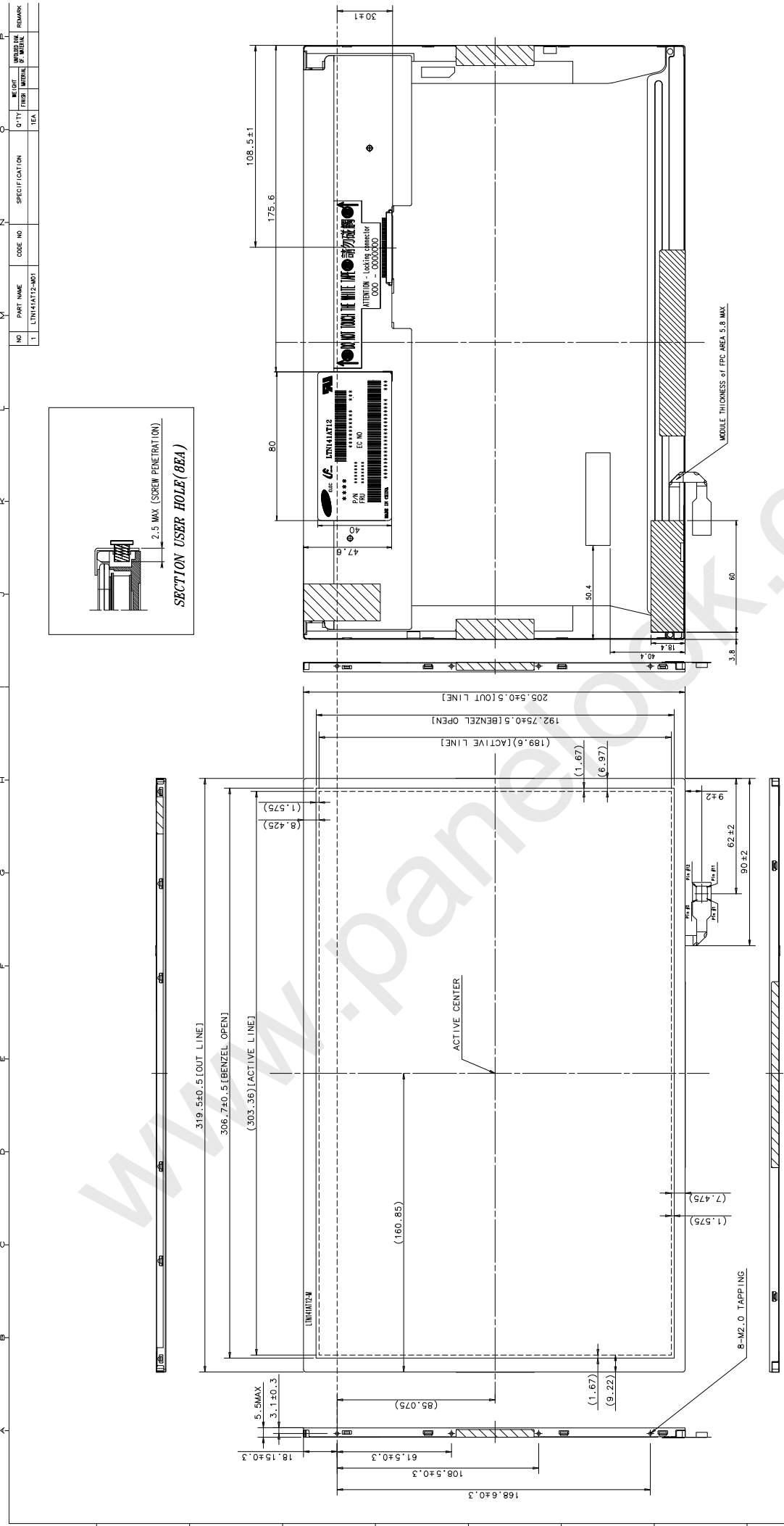

**\* NOTE**  
 1. INPUT SIGNAL INTERFACE CONNECTOR TO BE SPECIFIED AS BELOW.  
 - PART NO./MAKER : FI-XB30RSLZ-HF11/AE (or compatible)  
 2. CALIFERS MEASURING FORCE : 750 ± 150 gf  
 3. USER HOLE TORQUE SPEC : 2.5kgf/cm MAX (5 TIMES)  
 4. WEIGHT SPEC : 420 MAX

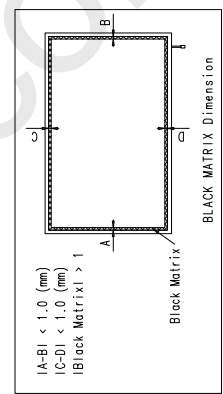

REV. DATE	DESCRIPTION OF REVISION	APP'D BY	CHK'D BY	REASON	CHK'D BY
SCALE	DWG. NO. BY	DES. BY	APP'D BY	L7N141ATT2-M01	
DRAW. NUMBER	J.C. DATE	A.S. DATE	P.C. NAME	PART/SHEET	
	DR. DATE	DR. DATE	SPEC. NO.	Outline Dimension	
SAMSUNG ELECTRONICS					CODE NO.
					VER. 000

## 8. Product Markings and Others

Approval

A nameplate bearing followed by is affixed to a shipped product at the specified location on each product.

- (1) Parts number : LTN141AT12-M01
- (2) Revision : One letter
- (3) Control code : One letter
- (4) Lot number : 6 X X XXX XX XX

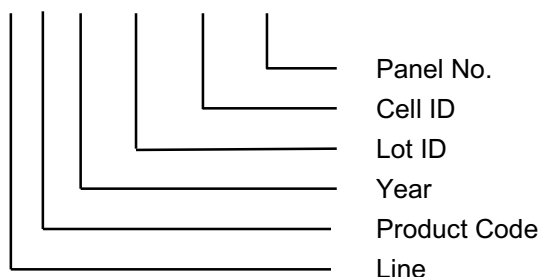

NOTE 1). This code indicating year is omitted in the products of Cheonan site.

### (5) Product Label Definition

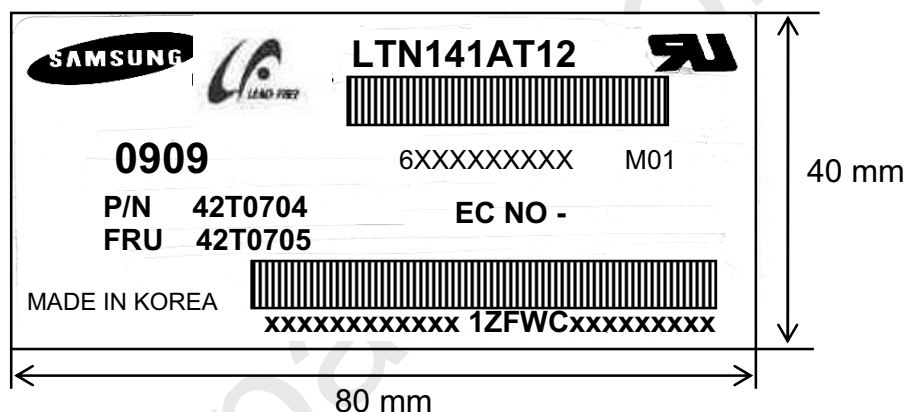

TFT-LCD Product name : LTN141AT12-M01  
 Lot number : 6XXXXXXXXXX  
 Revision Code : M01  
 Inspected work week : 0909(2009 Year, 9<sup>th</sup> week)  
 P/N : Lenovo Part Number (42T0704)  
 EC NO : Engineering Change Number (Blank)  
 FRU : Field Replaceable Unit Part Number(42T0705)  
 Header Code : 1ZFWC

**Samsung Secret**

Doc.No.	LTN141AT12-M01	Rev.No	04-A03-S-090424	Page	24 / 29
---------	----------------	--------	-----------------	------	---------



## 5.12. GENERAL PRECAUTIONS

Approval

### 1. Handling

- (a) When the module is assembled, It should be attached to the system firmly using every mounting holes. Be careful not to twist and bend the modules.
- (b) Refrain from strong mechanical shock and / or any force to the module. In addition to damage, this may cause improper operation or damage to the module and CCFT back-light.
- (c) Note that polarizers are very fragile and could be easily damaged. Do not press or scratch the surface harder than a HB pencil lead.
- (d) Wipe off water droplets or oil immediately. If you leave the droplets for a long time, Staining and discoloration may occur.
- (e) If the surface of the polarizer is dirty, clean it using some absorbent cotton or soft cloth.
- (f) The desirable cleaners are water, IPA (Isoprophyl Alcohol) or Hexane. Do not use Ketone type materials(ex. Acetone), Ethyl alcohol, Toluene, Ethyl acid or Methyl chloride. It might permanent damage to the polarizer due to chemical reaction.
- (g) If the liquid crystal material leaks from the panel, it should be kept away from the eyes or mouth. In case of contact with hands, legs or clothes, it must be washed away thoroughly with soap.
- (h) Protect the module from static, it may cause damage to the C-MOS Gate Array IC.
- (i) Use fingerstalls with soft gloves in order to keep display clean during the incoming inspection and assembly process.
- (j) Do not disassemble the module.
- (k) Do not pull or fold the lamp wire.
- (l) Do not adjust the variable resistor which is located on the back side.
- (m) Protection film for polarizer on the module shall be slowly peeled off just before use so that the electrostatic charge can be minimized.
- (n) Pins of I/F connector shall not be touched directly with bare hands.

**Samsung Secret**

<b>Doc.No.</b>	LTN141AT12-M01	<b>Rev.No</b>	04-A03-S-090424	<b>Page</b>	25 / 29
----------------	----------------	---------------	-----------------	-------------	---------

Approval

## 2. STORAGE

- (a) Do not leave the module in high temperature, and high humidity for a long time. It is highly recommended to store the module with temperature from 0 to 35 °C and relative humidity of less than 70%.
- (b) Do not store the TFT-LCD module in direct sunlight.
- (c) The module shall be stored in a dark place. It is prohibited to apply sunlight or fluorescent light during the store.

## 3. OPERATION

- (a) Do not connect,disconnect the module in the " Power On" condition.
- (b) Power supply should always be turned on/off by following item 6.3 " Power on/off sequence " .
- (c) Module has high frequency circuits. Sufficient suppression to the electromagnetic interference shall be done by system manufacturers. Grounding and shielding methods may be important to minimize the interference.
- (d) The cable between the back-light connector and its inverter power supply shall be a minimized length and be connected directly . The longer cable between the back-light and the inverter may cause lower luminance of lamp(CCFT) and may require higher startup voltage (Vs).
- (e) The standard limited warranty is only applicable when the module is used for general notebook applications. If used for purposes other than as specified, SEC is not to be held reliable for the defective operations. It is strongly recommended to contact SEC to find out fitness for a particular purpose.

## 4. OTHERS

- (a) Ultra-violet ray filter is necessary for outdoor operation.
- (b) Avoid condensation of water. It may result in improper operation or disconnection of electrode.
- (c) Do not exceed the absolute maximum rating value. ( the supply voltage variation, input voltage variation, variation in part contents and environmental temperature, so on) Otherwise the module may be damaged.
- (d) If the module displays the same pattern continuously for a long period of time,it can be the situation when the image "sticks" to the screen.
- (e) This module has its circuitry PCB's on the rear side and should be handled carefully in order not to be stressed.

Samsung Secret

Doc.No.	LTN141AT12-M01	Rev.No	04-A03-S-090424	Page	26 / 29
---------	----------------	--------	-----------------	------	---------

## 10. EDID

Approval

Address (HEX)	FUNCTION	Value	BIN	DEC	ASCII or Data	Notes
		HEX				
00	Header	00	00000000	0		EDID Header
01		FF	11111111	255		
02		FF	11111111	255		
03		FF	11111111	255		
04		FF	11111111	255		
05		FF	11111111	255		
06		FF	11111111	255		
07		00	00000000	0		
08	ID Manufacturer Name	30	00110000	48	L E N	3 character ID
09		AE	10101110	174		"LEN" as an end-customer
0A	ID Product Code	35	00110101	53		#WXGA LED
0B		40	01000000	64		
0C	32-bit serial no.	00	00000000	0		
0D		00	00000000	0		
0E		00	00000000	0		
0F		00	00000000	0		
10	Week of manufacture	00	00000000	0		
11	Year of manufacture	13	00010011	19	2009	2009
12	EDID Structure Ver.	01	00000001	1	1	EDID Ver. 1.0
13	EDID revision #	03	00000011	3	3	EDID Rev. 3
14	Video input definition	80	10000000	128		
15	Max H image size	1E	00011110	30	30	30 cm(approx)
16	Max V image size	13	00010011	19	19	19 cm(approx)
17	Display Gamma	78	01111000	120	2.2	Gamma 2.2
18	Feature support	EA	11101010	234		
19	Red/green low bits	01	00000001	1		10000111
1A	Blue/white low bits	F5	11110101	245		11111110
1B	Red x/ high bits	97	10010111	151	0.590	Red x 0.610= 10011100
1C	Red y	57	01010111	87	0.340	Red y 0.340= 01010111
1D	Green x	52	01010010	82	0.320	Green x 0.345= 01011000
1E	Green y	8A	10001010	138	0.540	Green y 0.544= 1000110011
1F	Blue x	27	00100111	39	0.155	Blue x 0.155= 00100111
20	Blue y	23	00100011	35	0.140	Blue y 0.070= 00010010
21	White x	50	01010000	80	0.313	White x 0.313= 01010000
22	White y	54	01010100	84	0.329	White y 0.329= 01010100
23	Established timing 1	00	00000000	0		
24	Established timing 2	00	00000000	0		
25	Established timing 3	00	00000000	0		

Samsung Secret

Doc.No.

LTN141AT12-M01

Rev.No

04-A03-S-090424

Page

27 / 29

Approval

26	Standard timing #1	01	00000001	1		not used
27		01	00000001	1		
28	Standard timing #2	01	00000001	1		not used
29		01	00000001	1		
2A	Standard timing #3	01	00000001	1		not used
2B		01	00000001	1		
2C	Standard timing #4	01	00000001	1		not used
2D		01	00000001	1		
2E	Standard timing #5	01	00000001	1		not used
2F		01	00000001	1		
30	Standard timing #6	01	00000001	1		not used
31		01	00000001	1		
32	Standard timing #7	01	00000001	1		not used
33		01	00000001	1		
34	Standard timing #8	01	00000001	1		not used
35		01	00000001	1		
36	Detailed timing/monitor descriptor #1	0E	00001110	14	82.06	Main clock= 82.06 MHz (@60Hz)
37		20	00100000	32		
38		00	00000000	0	1280	Hor active=640*2 pixels
39		88	10001000	136	392	Hor blanking=288 pixels
3A		51	01010001	81		4bit : 4bit
3B		20	00100000	32	800	Vertical active=800 lines
3C		12	00010010	18	18	Vertical blanking=16 lines
3D		30	00110000	48		4bit : 4bit
3E		34	00110100	52	52	Hor sync. Offset=52 pixels
3F		40	01000000	64	64	H sync. Width=64 pixels
40		33	00110011	51	3	V sync. Offset=3 lines
					3	V sync. Width=3 lines
41		00	00000000	0		2bit : 2bit :2bit :2bit
42		2F	00101111	47	303	H image size= 303 mm(approx)
43		BE	10111110	190	190	V image size = 190 mm(approx)
44		10	00010000	16		
45		00	00000000	0		No Horizontal Border
46	00	00000000	0		No Vertical Border	
47	19	00011001	25			
48	Detailed timing/monitor descriptor #2	49	01001001	73	57.05	Main clock= 57.05 MHz (@50Hz)
49		16	00010110	22		
4A		00	00000000	0	1280	Hor active=640*2 pixels
4B		58	01011000	88	88	Hor blanking=288 pixels
4C		50	01010000	80		4bit : 4bit
4D		20	00100000	32	800	Vertical active=800 lines
4E		22	00100010	34	34	Vertical blanking=24lines
4F		30	00110000	48		4bit : 4bit
50		34	00110100	52	52	Hor sync. Offset=52 pixels
51		40	01000000	64	64	H sync. Width=64 pixels
52		33	00110011	51	3	V sync. Offset=3 lines
					3	V sync. Width=3 lines
53		00	00000000	0		2bit : 2bit :2bit :2bit
54		2F	00101111	47	303	H image size= 303 mm(approx)
55		BE	10111110	190	190	V image size = 190 mm(approx)
56		10	00010000	16		
57		00	00000000	0		No Horizontal Border
58	00	00000000	0		No Vertical Border	
59	19	00011001	25			

Samsung Secret

Doc.No.

LTN141AT12-M01

Rev.No

04-A03-S-090424

Page

28 / 29

Approval

5A	descriptor #3	00	00000000	0		Manufacturer Specified (Timing)  (Horizontal active pixel /8)-31 Image Aspect Ratio(16:10) Low Refresh Rate #1(50Hz) (Horizontal active pixel /8)-31 Image Aspect Ratio(16:10) Low Refresh Rate #1(40Hz) Brightness(1/10nit) Feature flag(TN/LEDmode)
5B		00	00000000	0		
5C		00	00000000	0		
5D		0F	00001111	15		
5E		00	00000000	0		
5F		81	10000001	129		
60		0A	00001010	10		
61		32	00110010	50		
62		81	10000001	129		
63		0A	00001010	10		
64		28	00101000	40		
65		16	00010110	22		
66		09	00001001	9		
67		00	00000000	0		
68		4C	01001100	76		
69		A3	10100011	163		
6A	41	01000001	65	[A]		
6B	54	01010100	84	[T]		
6C	Detailed timing/monitor descriptor #4	00	00000000	0		Monitor Name Tag (ASCII)
6D		00	00000000	0		
6E		00	00000000	0		
6F		FE	11111110	254		
70		00	00000000	0		
71		4C	01001100	76	[L]	
72		54	01010100	84	[T]	
73		4E	01001110	78	[N]	
74		31	00110001	49	[1]	
75		34	00110100	52	[4]	
76		31	00110001	49	[1]	
77		41	01000001	65	[A]	
78		54	01010100	84	[T]	
79		31	00110001	49	[1]	
7A		32	00110010	50	[2]	
7B		4D	01001101	77	[M]	
7C	30	00110000	48	[0]		
7D	31	00110001	49	[1]		
7E	Extension Flag	00	00000000	0		
7F	Checksum	25	00100101	37		

Samsung Secret