

SAMSUNG**ELECTRONICS**

Approval



DATE : Feb. 9, 2011.

SAMSUNG TFT-LCD**MODEL NO. : LTN141AT15-B**

NOTE : Extension code [-B]
→ LTN141AT15-B
Surface type [**Anti- Glare**]

Any modification of Spec is not allowed without SEC's permission

**Application Engineer Part,
SAMSUNG ELECTRONICS CO., LTD.**

Samsung Secret**Doc.No.**

LTN141AT15-B

Rev.No.

04-A00-G-110209

Page

1 / 27

CONTENTS

Revision History	-----	(3)
General Description	-----	(4)
1. Absolute Maximum Ratings	-----	(5)
1.1 Absolute Ratings of environment		
1.2 Electrical Absolute Ratings		
2. Optical Characteristics	-----	(7)
3. Electrical Characteristics	-----	(10)
3.1 TFT LCD Module		
3.2 Backlight Unit		
3.3 LED Driver		
4. Block Diagram	-----	(13)
4.1 TFT LCD Module		
5. Input Terminal Pin Assignment	-----	(14)
5.1 Input Signal & Power		
5.2 LVDS Interface		
5.3 Timing Diagrams of LVDS For Transmitting		
5.4 Input Signals, Basic Display Colors and Gray Scale of Each Color.		
5.5 Pixel format		
6. Interface Timing		
6.1 Timing Parameters	-----	(19)
6.2 Timing Diagrams of interface Signal		
6.3 Power ON/OFF Sequence		
7. Outline Dimension	-----	(21)
8. Packing	-----	(23)
9. Markings & Others	-----	(24)
10. General Precaution	-----	(26)

Samsung Secret

REVISION HISTORY

Approval

Date	Revision No.	Page	Summary
Feb. 9. 2011	A00	All	The Preliminary specification of LTN141AT15-B was issued first.

Samsung Secret**Doc.No.**

LTN141AT15-B

Rev.No

04-A00-G-110209

Page

3 / 27

GENERAL DESCRIPTION

DESCRIPTION

LTN141AT15-B is a color active matrix TFT (Thin Film Transistor) liquid crystal display (LCD) that uses amorphous silicon TFT as switching devices. This model is composed of a TFT LCD panel, a driver circuit and a backlight system. The resolution of a 14.1" contains 1280 x 800 pixels and can display up to 262,144 colors. 6 O'clock direction is the Optimum viewing angle.

FEATURES

- High contrast ratio, high aperture structure
- 1280 x 800 pixels resolution
- Fast Response Time
- Low power consumption
- LED BLU Structure
- DE (Data enable) only mode.
- 3.3V LVDS Interface
- On board EDID chip
- RoHS Compliance

APPLICATIONS

- Notebook PC
- If the usage of this product is not for PC application, but for others, please contact SEC

GENERAL INFORMATION

Item	Specification	Unit	Note
Display area	303.36(H) X 189.6(V) (14.1"diagonal)	mm	
Driver element	a-si TFT active matrix		
Display colors	262,144		
Number of pixel	1280 x 800	pixel	
Pixel arrangement	RGB vertical stripe		
Pixel pitch	0.237(H) x 0.237(V)	mm	
Display Mode	Normally white		
Surface treatment	Haze 25, Hard-Coating 2H		

Samsung Secret

Approval

Mechanical Information

Item		Min.	Typ.	Max.	Unit	Note
Module size	Horizontal (H)	319.0	319.5	320.0	mm	
	Vertical (V)	205.0	205.5	206.0	mm	
	Depth (D)	-	-	5.5	mm	(1)
Weight		-	395	410	g	

Note (1) Measurement condition of outline dimension
 . Equipment : Vernier Calipers
 . Push Force : 500g · f (minimum)

1. ABSOLUTE MAXIMUM RATINGS

1.1 ENVIRONMENTAL ABSOLUTE RATINGS

Item	Symbol	Min.	Max.	Unit	Note
Storage temperate	TSTG	-20	60	°C	(1)
Operating temperate (Temperature of glass surface)	TOPR	0	50	°C	(1)
Shock (non-operating)	Snop	-	240	G	(2),(4)
Vibration (non-operating)	Vnop	-	2.41	G	(3),(4)

Note (1) Temperature and relative humidity range are shown in the figure below.
 95 % RH Max. ($40\text{ }^{\circ}\text{C} \geq T_a$)
 Maximum wet - bulb temperature at $39\text{ }^{\circ}\text{C}$ or less. ($T_a > 40\text{ }^{\circ}\text{C}$) No condensation

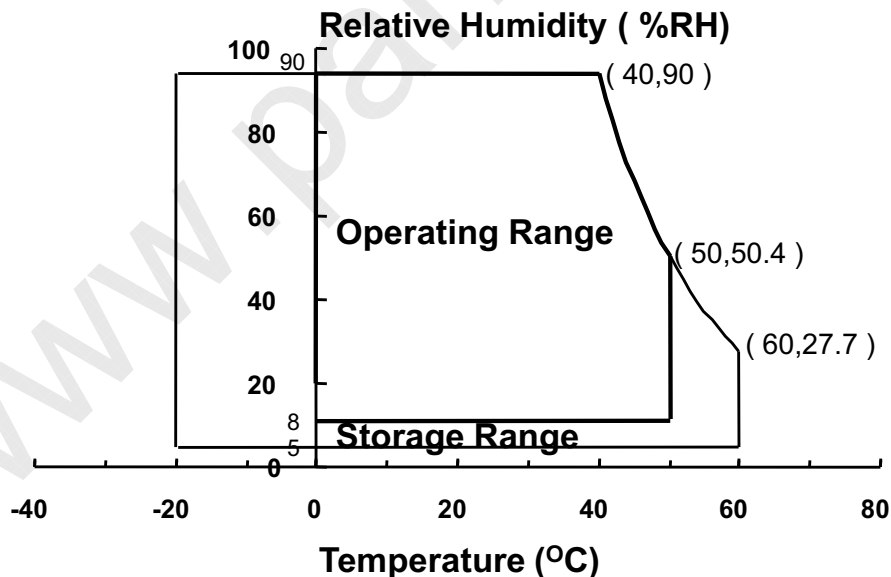

- (2) 2ms, half sine wave, one time for $\pm X, \pm Y, \pm Z$.
 (3) 5 - 500 Hz, random vibration, 30min for X, Y, Z.
 (4) At testing Vibration and Shock, the fixture in holding the Module to be tested have to be hard and rigid enough so that the Module would not be twisted or bent by the fixture.

Samsung Secret

1.2 ELECTRICAL ABSOLUTE RATINGS

(1) TFT LCD MODULE

VDD =3.3V, Vss = GND =0V

Item	Symbol	Min.	Max.	Unit	Note
Power Supply Voltage	V _{DD}	V _{DD} - 0.3	V _{DD} + 0.3	V	(1)
Logic Input Voltage	V _{IN}	V _{DD} - 0.3	V _{DD} + 0.3	V	(1)

Note (1) Within Ta (25 ± 2 °C)

(2) BACK-LIGHT UNIT

Ta = 25 ± 2 °C

Item	Symbol	Min.	Typ.	Max.	Unit	Note
LED Current	I _L	-	20	-	mA	(1)
LED Voltage	F _L	-	3.2	-	V	(1)

Note 1) Permanent damage to the device may occur if maximum values are exceeded
Functional operation should be restricted to the conditions described under normal operating conditions.

Samsung Secret

2. OPTICAL CHARACTERISTICS

The following items are measured under stable conditions. The optical characteristics should be measured in a dark room or equivalent state with the methods shown in Note (5).
Measuring equipment : TOPCON SR-3 and PR-650

* Ta = 25 ± 2 °C, V_{DD}=3.3V, fv= 60Hz, fd_{CLK}= 69.22MHz, IL = 20mA

Item		Symbol	Condition	Min.	Typ.	Max	Unit	Note
Contrast Ratio (5 Points)		CR	Normal Viewing Angle φ = 0 θ = 0	-	300	-	-	(1), (2), (5)
Response Time at Ta	Rising	T _R		-	16	-	msec	(1), (3)
	Falling	T _F		-	16	-		
Average Luminance of White (5 Points)		Y _{L,AVE}		190	220	-	cd/m ²	(1), (4)
Color Chromaticity (CIE)	Red	R _X		0.550	0.580	0.610	-	(1), (5) SR-3
		R _Y		0.310	0.340	0.370		
	Green	G _X		0.315	0.345	0.375		
		G _Y		0.520	0.550	0.580		
	Blue	B _X		0.121	0.151	0.181		
		B _Y		0.070	0.100	0.130		
	White	W _X	0.283	0.313	0.343			
		W _Y	0.299	0.329	0.359			
Viewing Angle	Hor.	θ _L	40	45	-	Degrees	(1), (5) SR-3	
		θ _H	40	45	-			
	Ver.	φ _H	10	15	-			
		φ _L	30	35	-			
Color Gamut		CG	-	45	-			
Brightness Uniformity		δ _{L5}	5points	80	-	-	%	(6)
		δ _{L13}	13points	60	-	-		

Samsung Secret

Approval

Note 1) Definition of Viewing Angle : Viewing angle range($10 \leq C/R$)

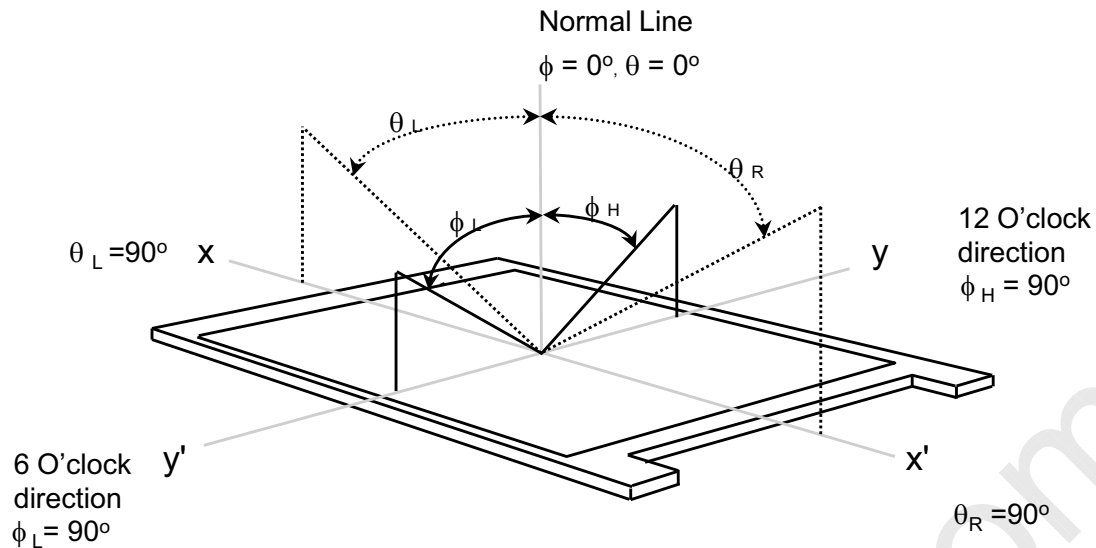

Note 2) Definition of Contrast Ratio (CR) : Ratio of gray max (Gmax) ,gray min (Gmin) at 5 points(4, 5, 7, 9, 10)

$$CR = \frac{CR(4) + CR(5) + CR(7) + CR(9) + CR(10)}{5}$$

Points : (4) , (5) , (7) , (9) , (10) at the figure of Note (6).

Note 3) Definition of Response time :

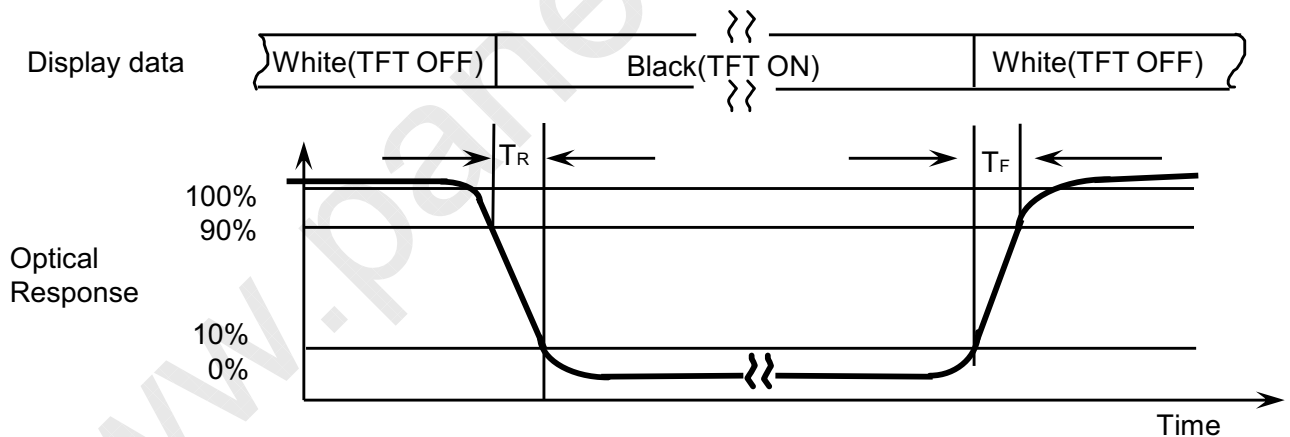

Note 4) Definition of Average Luminance of White : measure the luminance of white at 5 points.

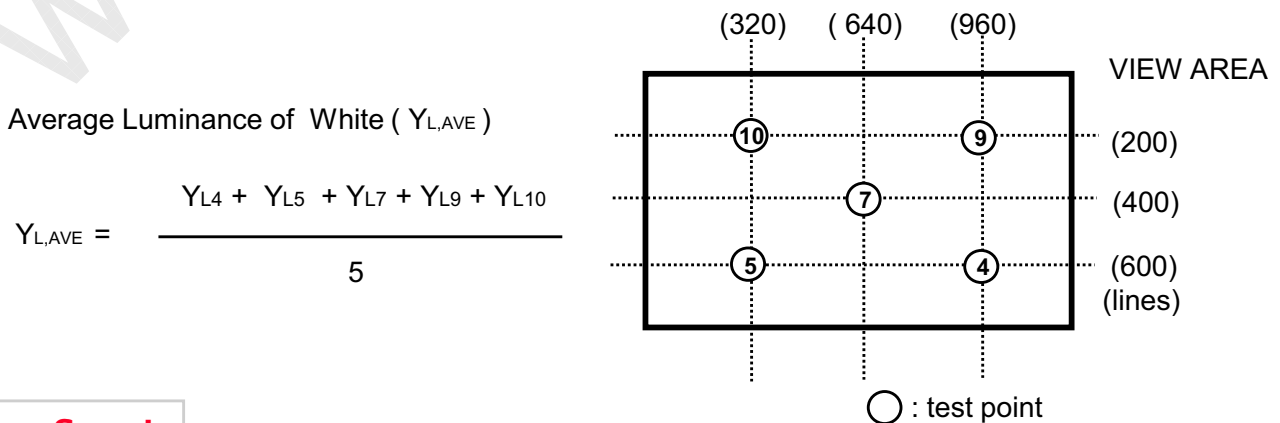

Samsung Secret

Approval

Note 5) After stabilizing and leaving the panel alone at a given temperature for 30 min , the measurement should be executed. Measurement should be executed in a stable, windless, and dark room. 30 min after lighting the backlight. This should be measured in the center of screen.
 Environment condition : $T_a = 25 \pm 2 \text{ }^\circ\text{C}$

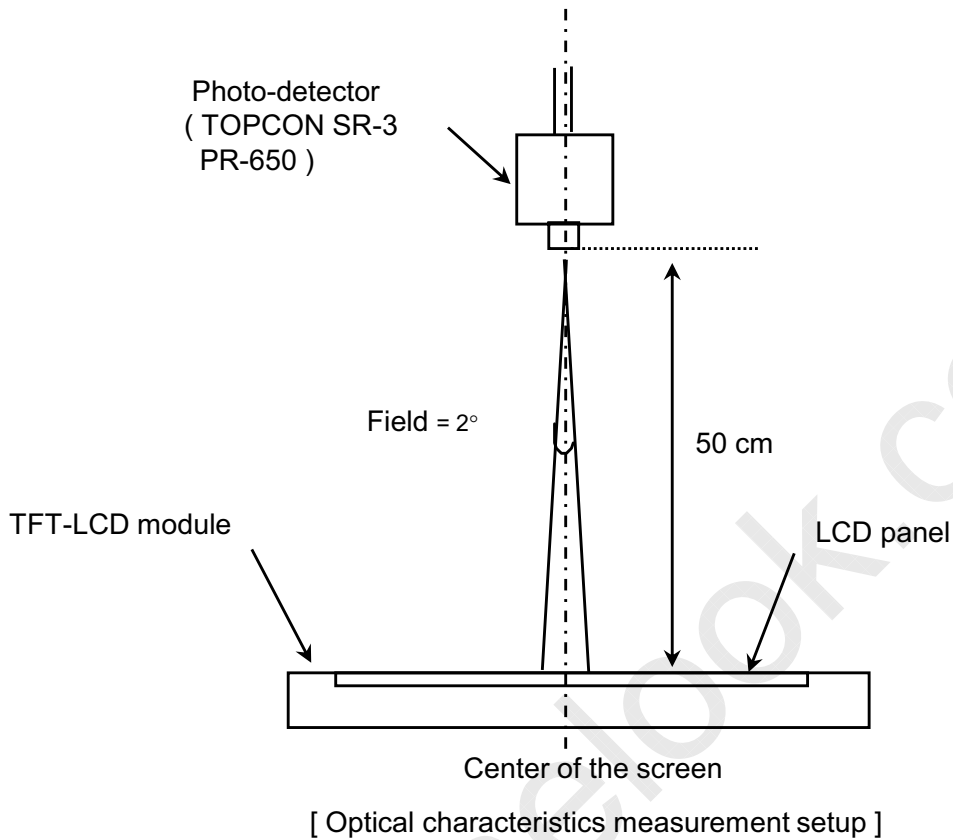

Note 6) Definition of 13 points white variation (δL), [① ~ ⑬]

$$\delta L = \frac{\text{Maximum luminance of 13 points}}{\text{Minimum luminance of 13 points}}$$

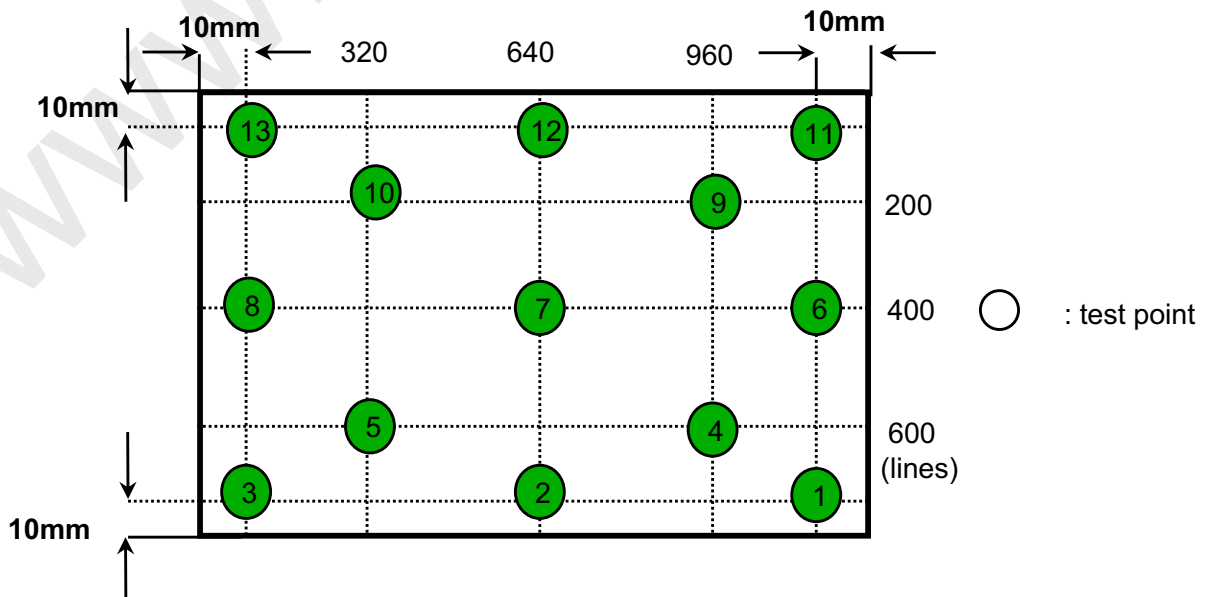

Samsung Secret

3. ELECTRICAL CHARACTERISTICS

Approval

3.1 TFT LCD MODULE

Ta= 25 ± 2°C

Item		Symbol	Min.	Typ.	Max.	Unit	Note
Voltage of Power Supply		V _{DD}	3.0	3.3	3.6	V	
Differential Input Voltage for LVDS Receiver Threshold	High	V _{IH}	-	-	+100	mV	V _{CM} = +1.2V
	Low	V _{IL}	-100	-	-	mV	
Vsync Frequency	60Hz	Hsync Freq	F _H	45.97	48.96	60.11	KHz
		Main Freq	F _{DCLK}	65	69.22	85	MHz
	50Hz	Hsync Freq	F _H	39.06	41.60	51.08	KHz
		Main Freq	F _{DCLK}	65	69.22	85	MHz
	40Hz	Hsync Freq	F _H	39.06	32.68	51.08	KHz
		Main Freq	F _{DCLK}	65	69.22	85	MHz
Rush Current		I _{RUSH}	-	-	1.5	A	(4)
Current of Power Supply	White	I _{DD}	-	300	-	mA	(2),(3)*a
	Mosaic		-	350	-	mA	(2),(3)*b
	V. Stripe		-	395	485	mA	(2),(3)*c

Note (1) Display data pins and timing signal pins should be connected.(GND = 0V)

(2) $f_v = (60)\text{Hz}$, $f_{DCLK} = (69.22)\text{MHz}$, $V_{DD} = (3.3)\text{V}$, DC Current.

(3) Power dissipation pattern

*a) White Pattern

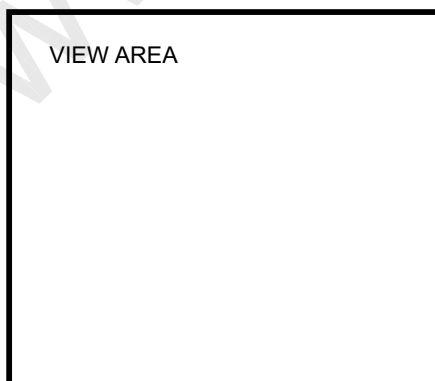

*b) Mosaic Pattern

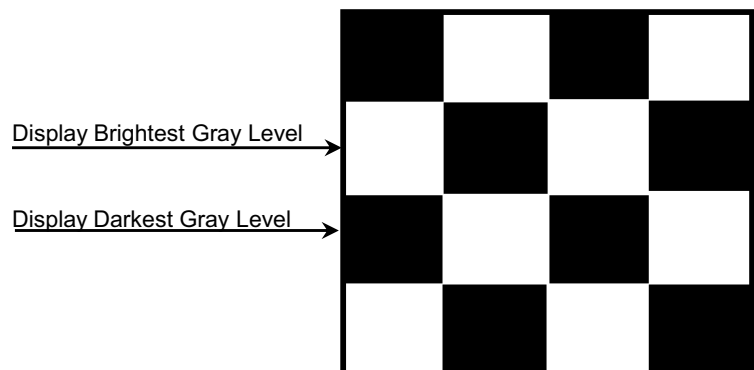

Samsung Secret

Approval

*c) 1dot Vertical stripe pattern

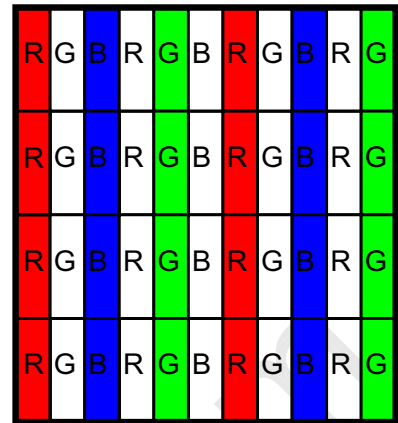
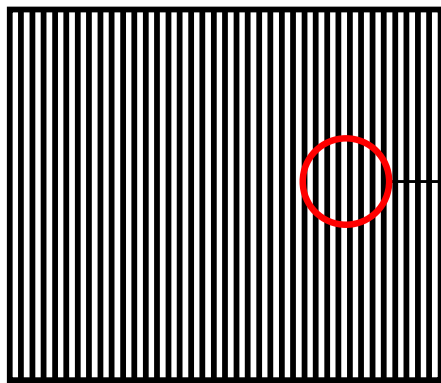

4) Rush current measurement condition

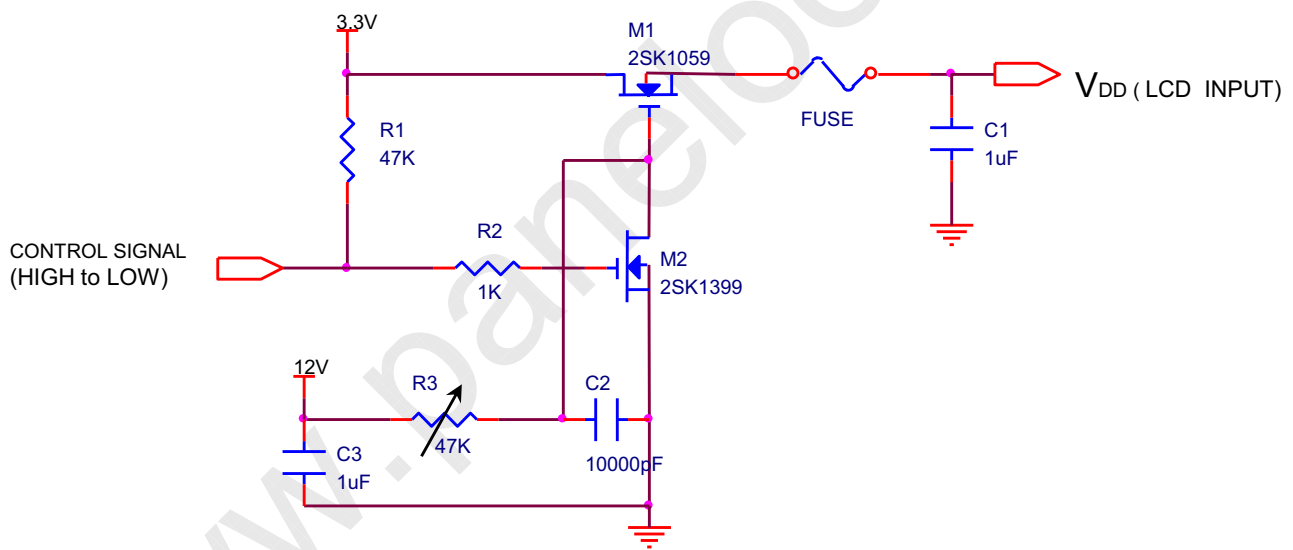

V_{DD} rising time is 470us

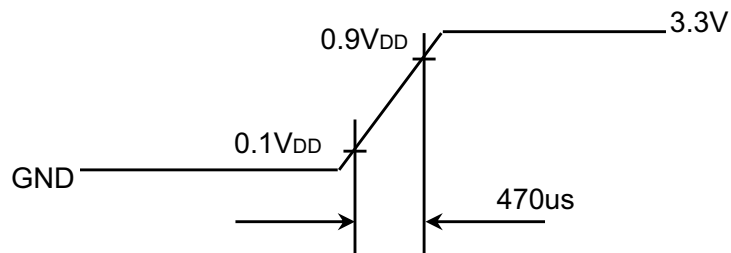

Samsung Secret

Approval

3.2 BACK-LIGHT UNIT

Ta= 25 ± 2 °C

Item	Symbol	Min.	Typ.	Max.	Unit	Note
LED Forward Current	IF	-	20	-	mA	
LED Forward Voltage	VF	-	3.2	-	V	
LED Array Voltage	VP	-	22.4	-	V	VF X 7 LEDs
Power Consumption	P	-	3.5	3.85	W	(IF X VF X 42LEDs)
Operating Life time	Hr	10,000			Hr	(1)

Note (1) Life time (Hr) of LEDs can be defined as the time in which it continues to operate under the condition Ta= 25 ± 2 °C and IF = 20.0mA until below event occurs.

- When the brightness becomes 50% or lower than the original.

3.3 LED Driver

-LED Driver Manufacturer (P/N) : Richtek (RT8561A)

Ta= 25 ± 2 °C

Item	Symbol	Min.	Typ.	Max.	Unit	Note
Input Voltage	V _{in}	7	12	21	V	
Duty Ratio		1	-	100	%	100~300Hz
		5	-	100	%	300Hz~1KHz
		10	-	100	%	1~10KHz
PWM Frequency	F _{pwm}	0.1	-	10	Khz	
Operating Frequency	F _o	675	750	825	kHz	600KHz Possible
Efficiency	η	80			%	

Samsung Secret

4. BLOCK DIAGRAM

4.1 TFT LCD Module

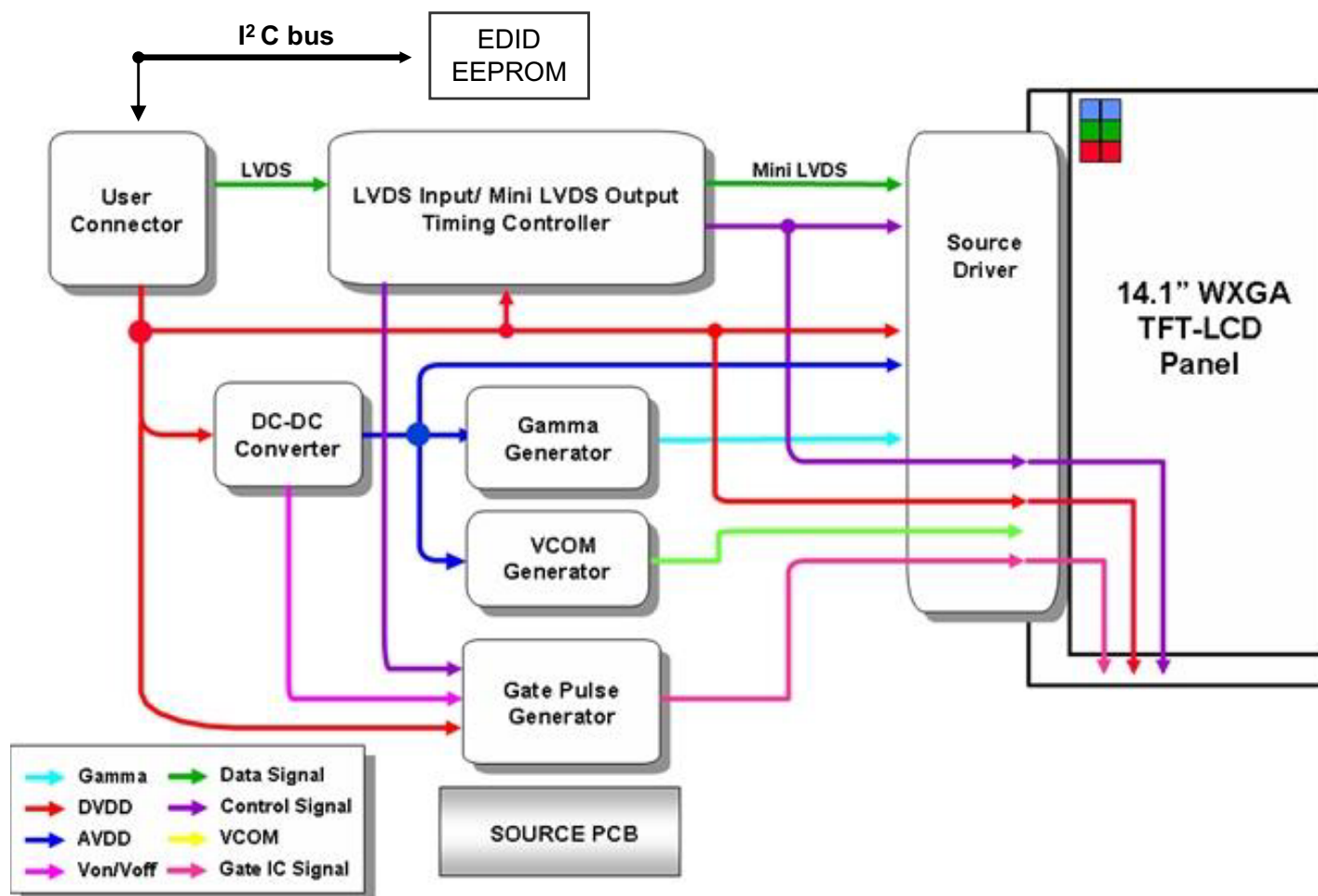

4.2 LED connection and placement

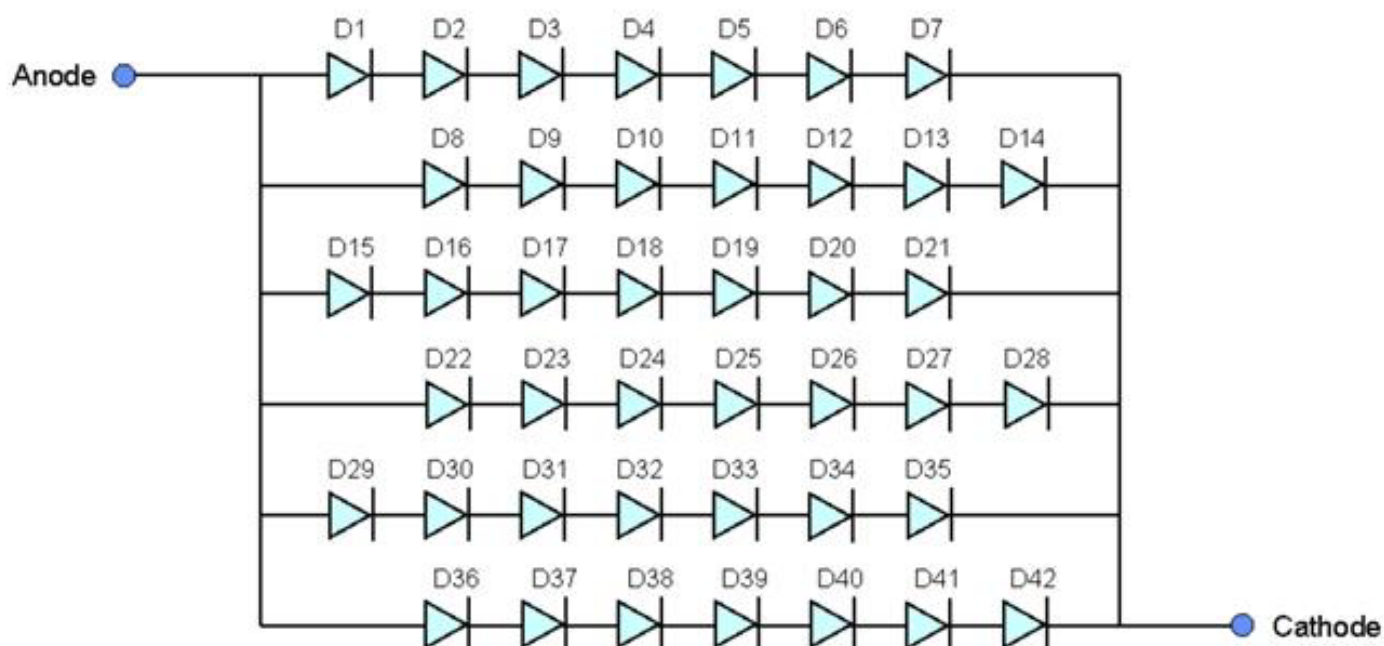

Samsung Secret

5. INPUT TERMINAL PIN ASSIGNMENT

5.1. Input Signal & Power (Connector : I-PEX, 20455-040E)

Pin	Symbol	Function
1	NC	No Connection (Reserved for supplier)
2	VCC	Power Supply, 3.3V (typical)
3	VCC	Power Supply, 3.3V (typical)
4	VCC_EDID	DDC 3.3V power
5	NC	No Connection (Reserved for supplier)
6	CLK_EDID	DDC Clock
7	DATA_EDID	DDC Data
8	RXin0-	- LVDS differential data (R0-R5, G0)
9	RXin0+	+ LVDS differential data (R0-R5, G0)
10	GND	Ground
11	RXin1-	- LVDS differential data (G1-G5, B0-B1)
12	RXn1+	+ LVDS differential data (G1-G5, B0-B1)
13	GND	Ground
14	RXin2-	- LVDS differential data (B2-B5,HS,VS, DE)
15	RXn2+	+ LVDS differential data (B2-B5,HS,VS, DE)
16	GND	Ground
17	ClKIN-	- LVDS differential clock input
18	ClKIN+	+ LVDS differential clock input
19	GND	Ground
20~21	NC	No Connection
22	NC	Ground
23~24	NC	No Connection
25	NC	Ground
26~27	NC	No Connection
28	NC	Ground
29~30	NC	No Connection
31~33	VBL-	LED Ground
34	NC	No Connection
35	PWM	PWM for luminance control
36	LED_EN	BL On/Off (On: 2.0~3.3V, Off: 0~0.5V)
37	NC	No Connection
38~40	VBL(7~21)	*LED Power Supply 7V-21V

Samsung Secret

5.2 LVDS Interface : Transmitter DS90CF363 or Compatible

LVDS

Pin No.	Name	RGB Signal	Pin No.	Name	RGB Signal
44	TxIN0	RO0	12	TxIN11	GO5
45	TxIN1	RO1	13	TxIN12	BO0
47	TxIN2	RO2	15	TxIN13	BO1
48	TxIN3	RO3	16	TxIN14	BO2
1	TxIN4	RO4	18	TxIN15	BO3
3	TxIN5	RO5	19	TxIN16	BO4
4	TxIN6	GO0	20	TxIN17	BO5
6	TxIN7	GO1	22	TxIN18	Hsync
7	TxIN8	GO2	23	TxIN19	Vsync
9	TxIN9	GO3	25	TxIN20	DE
10	TxIN10	GO4	26	TxCLK IN	Clock

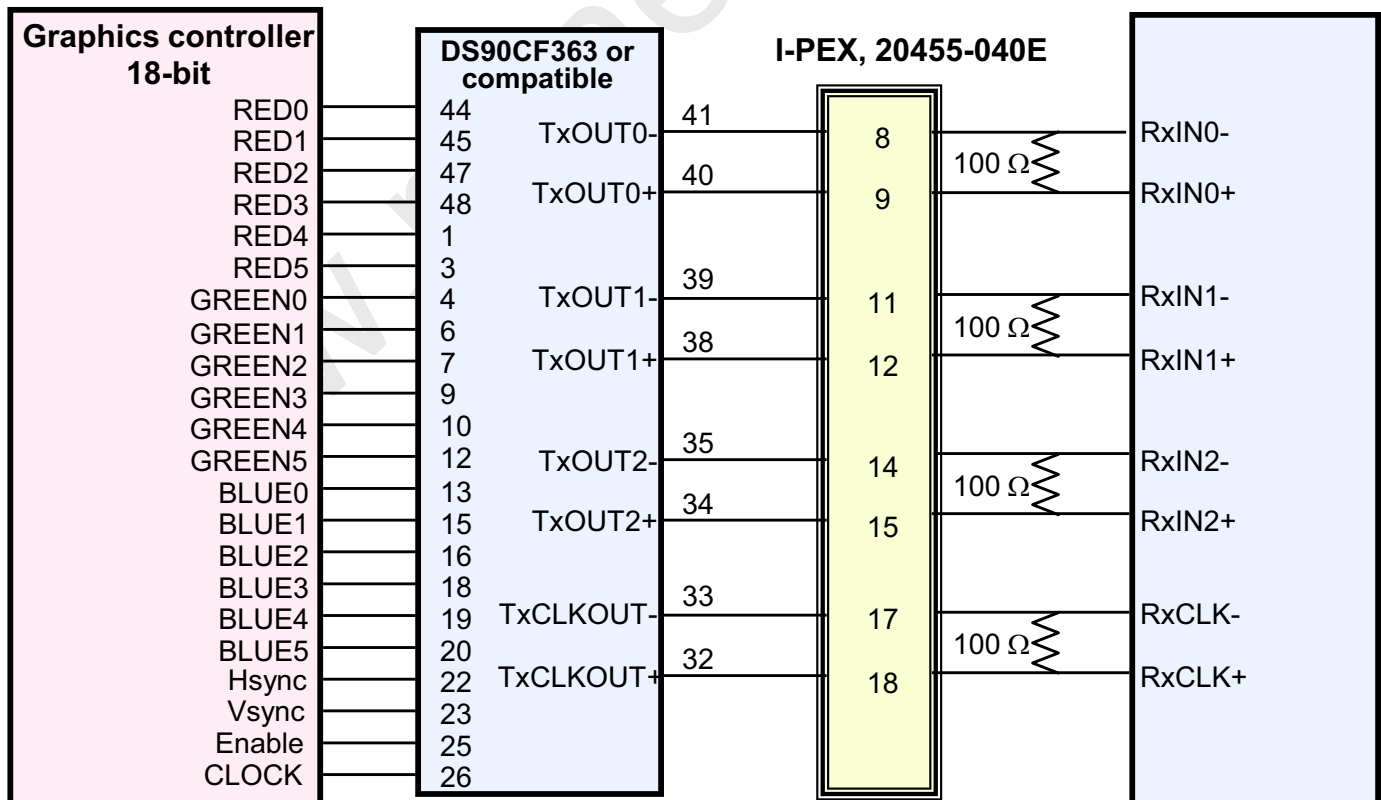
LVDS Interface

Note : The LCD Module uses a 100ohm resistor between positive and negative lines of each receiver input.

Samsung Secret

Approval

5.3 Timing Diagrams of LVDS For Transmission

LVDS Receiver : Integrated T-CON

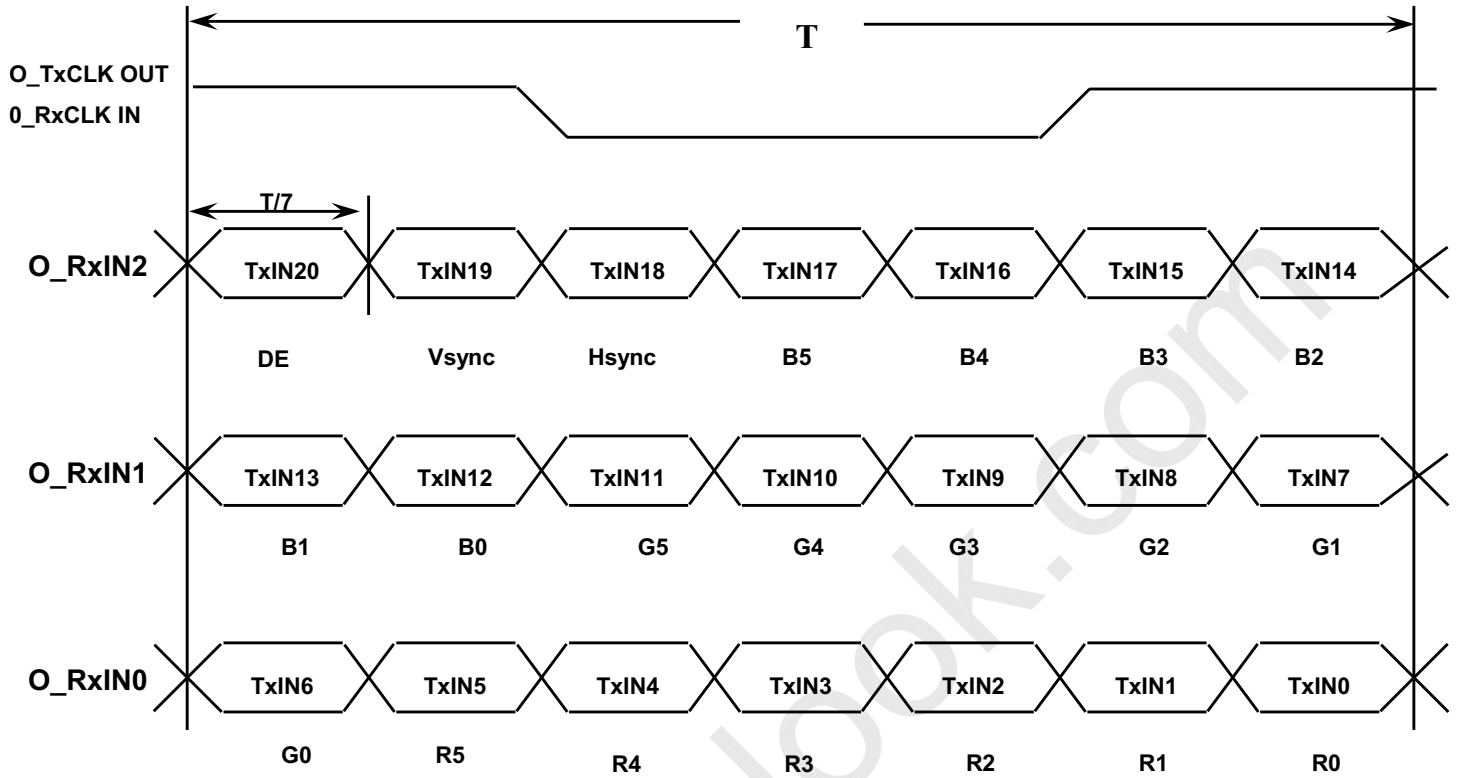

Samsung Secret

Approval

5.4 Input Signals, Basic Display Colors and Gray Scale of Each Color

Color	Display	Data Signal																	Gray Scale Level	
		Red					Green					Blue								
		R0	R1	R2	R3	R4	R5	G0	G1	G2	G3	G4	G5	B0	B1	B2	B3	45		B5
Basic Colors	Black	0	0	0	0	0	0	0	0	0	0	0	0	0	0	0	0	0	0	-
	Blue	0	0	0	0	0	0	0	0	0	0	0	0	1	1	1	1	1	1	-
	Green	0	0	0	0	0	0	1	1	1	1	1	1	0	0	0	0	0	0	-
	Cyan	0	0	0	0	0	0	1	1	1	1	1	1	1	1	1	1	1	1	-
	Red	1	1	1	1	1	1	0	0	0	0	0	0	0	0	0	0	0	0	-
	Magenta	1	1	1	1	1	1	0	0	0	0	0	0	1	1	1	1	1	1	-
	Yellow	1	1	1	1	1	1	1	1	1	1	1	1	0	0	0	0	0	0	-
	White	1	1	1	1	1	1	1	1	1	1	1	1	1	1	1	1	1	1	-
Gray Scale Of Red	Black	0	0	0	0	0	0	0	0	0	0	0	0	0	0	0	0	0	R0	
	Dark	1	0	0	0	0	0	0	0	0	0	0	0	0	0	0	0	0	R1	
	↑	0	1	0	0	0	0	0	0	0	0	0	0	0	0	0	0	0	R2	
	:	:	:	:	:	:	:	:	:	:	:	:	:	:	:	:	:	:	R3~R60	
	:	:	:	:	:	:	:	:	:	:	:	:	:	:	:	:	:	:		
	↓	1	0	1	1	1	1	0	0	0	0	0	0	0	0	0	0	0	R61	
	Light	0	1	1	1	1	1	0	0	0	0	0	0	0	0	0	0	0	R62	
	Red	1	1	1	1	1	1	0	0	0	0	0	0	0	0	0	0	0	R63	
Gray Scale Of Green	Black	0	0	0	0	0	0	0	0	0	0	0	0	0	0	0	0	0	G0	
	Dark	0	0	0	0	0	0	1	0	0	0	0	0	0	0	0	0	0	G1	
	↑	0	0	0	0	0	0	0	1	0	0	0	0	0	0	0	0	0	G2	
	:	:	:	:	:	:	:	:	:	:	:	:	:	:	:	:	:	:	G3~G60	
	:	:	:	:	:	:	:	:	:	:	:	:	:	:	:	:	:	:		
	↓	0	0	0	0	0	0	1	0	1	1	1	1	0	0	0	0	0	G61	
	Light	0	0	0	0	0	0	0	1	1	1	1	1	0	0	0	0	0	G62	
	Green	0	0	0	0	0	0	1	1	1	1	1	1	0	0	0	0	0	G63	
Gray Scale Of Blue	Black	0	0	0	0	0	0	0	0	0	0	0	0	0	0	0	0	0	B0	
	Dark	0	0	0	0	0	0	0	0	0	0	0	1	0	0	0	0	0	B1	
	↑	0	0	0	0	0	0	0	0	0	0	0	0	1	0	0	0	0	B2	
	:	:	:	:	:	:	:	:	:	:	:	:	:	:	:	:	:	:	B3~B60	
	:	:	:	:	:	:	:	:	:	:	:	:	:	:	:	:	:	:		
	↓	0	0	0	0	0	0	0	0	0	0	0	0	1	0	1	1	1	B61	
	Light	0	0	0	0	0	0	0	0	0	0	0	0	0	1	1	1	1	B62	
	Blue	0	0	0	0	0	0	0	0	0	0	0	0	1	1	1	1	1	B63	

Note 1) Definition of gray :

Rn: Red gray, Gn: Green gray, Bn: Blue gray (n=gray level)

Note 2) Input signal: 0 =Low level voltage, 1=High level voltage

Samsung Secret

Approval

5.5 Pixel Format in the display

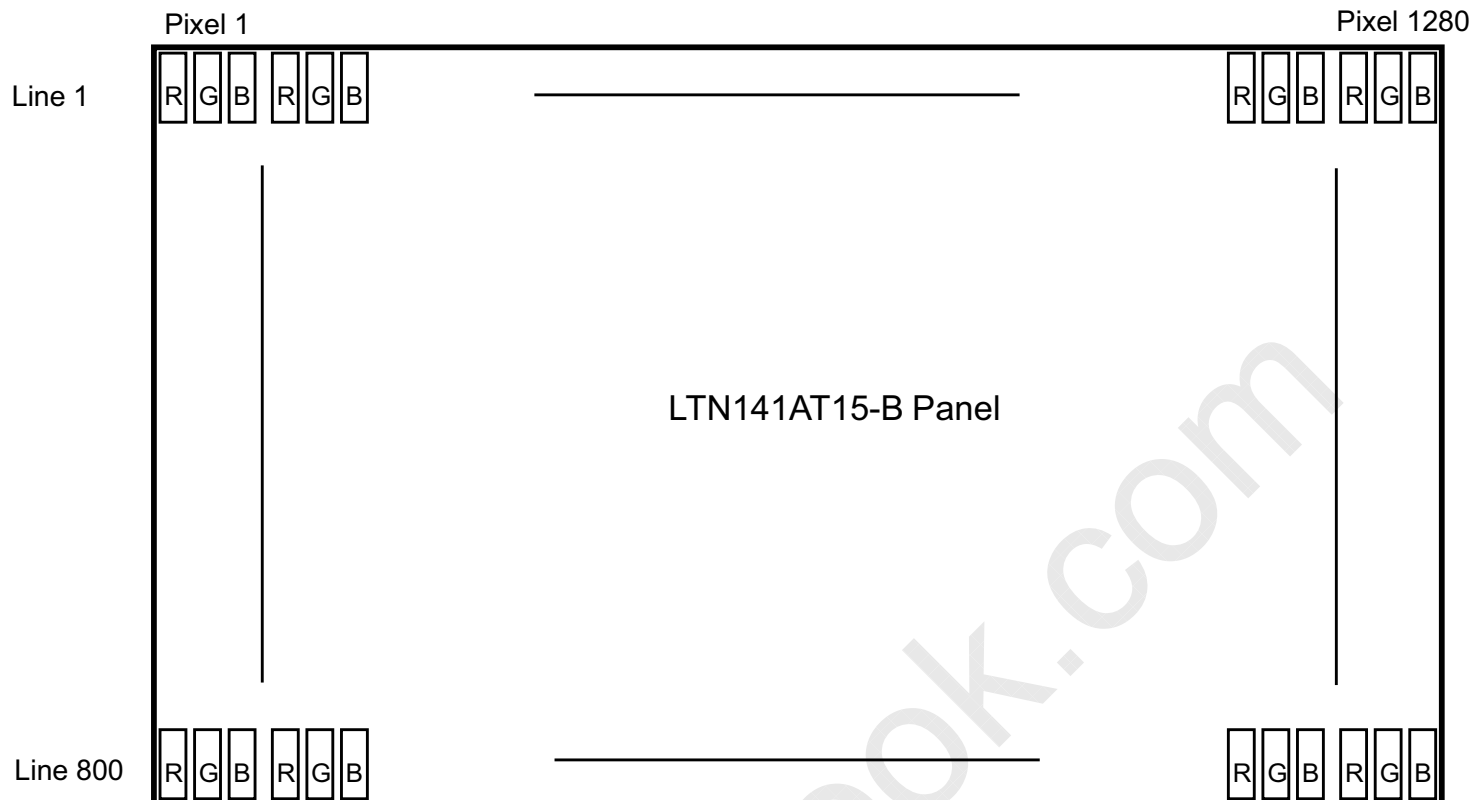

www.panelook.com

Samsung Secret

6. INTERFACE TIMING

6.1 Timing Parameters

Signal	Item	Symbol	Min.	Typ.	Max.	Unit	Note
Frame Frequency	Cycle	TV	808	817	900	Lines	-
Vertical Active Display Term	Display Period	TVD	-	800	-	Lines	-
One Line Scanning Time	Cycle	TH	1344	1412	1650	Clocks	-
Horizontal Active Display Term	Display Period	THD	-	1280	-	Clocks	-

6.2 Timing diagrams of interface signal

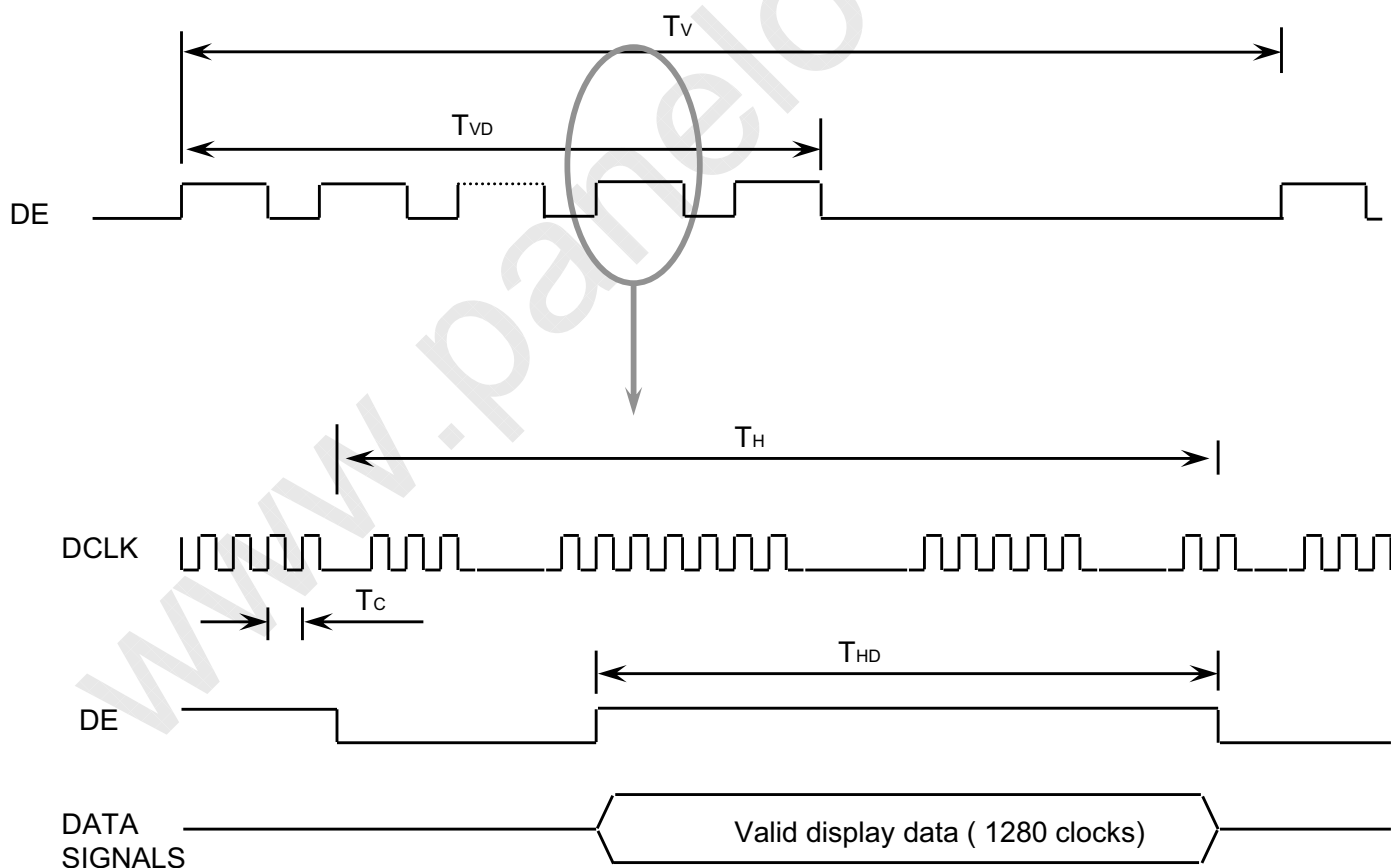

Samsung Secret

6.3 Power ON/OFF Sequence

: To prevent a latch-up or DC operation of the LCD module, the power on/off sequence should be as the diagram below.

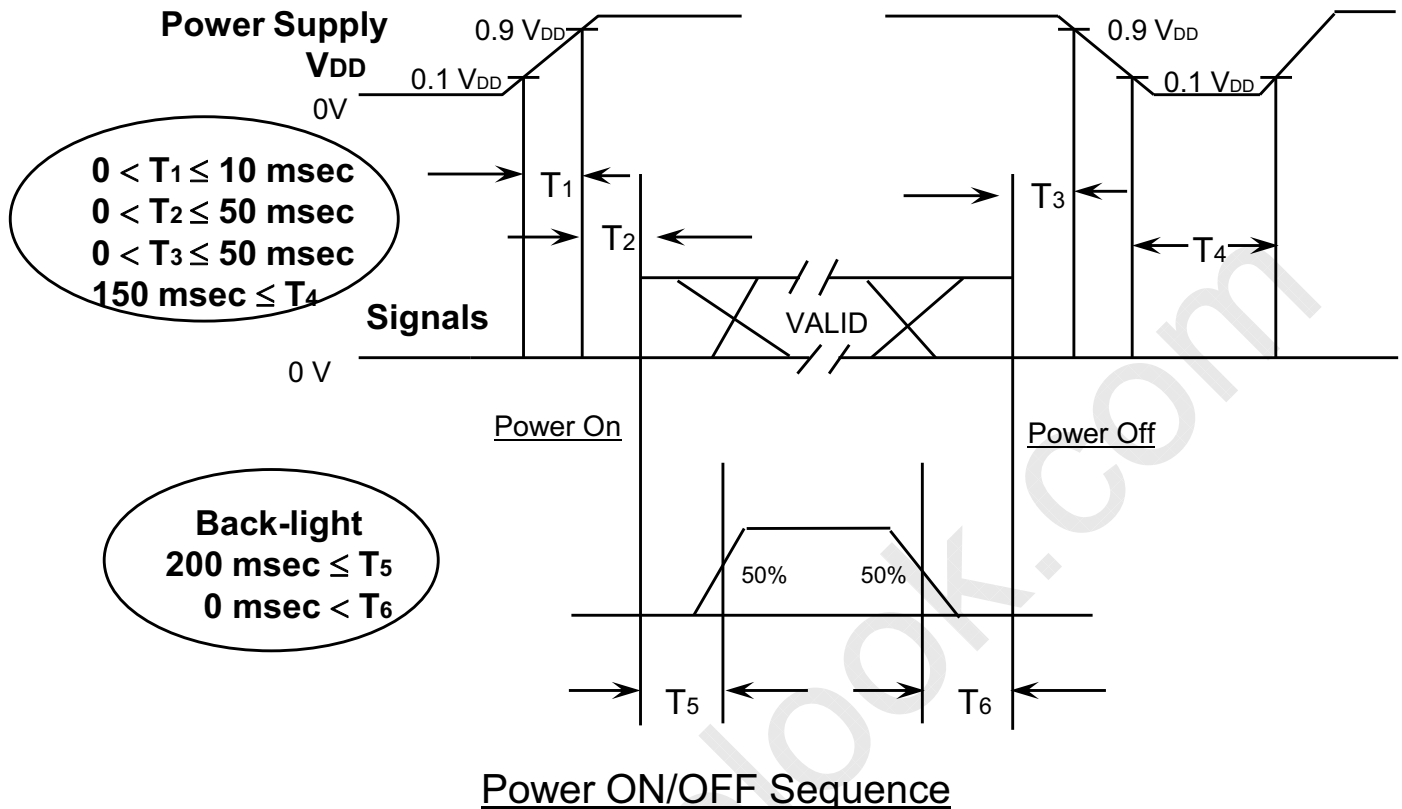

Power ON/OFF Sequence

T1 : Vdd rising time from 10% to 90%

T2 : The time from Vdd to valid data at power ON.

T3 : The time from valid data off to Vdd off at power Off.

T4 : Vdd off time for Windows restart

T5 : The time from valid data to B/L enable at power ON.

T6 : The time from valid data off to B/L disable at power Off.

NOTE.

- (1) The supply voltage of the external system for the module input should be the same as the definition of V_{DD}.
- (2) Apply the lamp voltage within the LCD operation range. When the back-light turns on before the LCD operation or the LCD turns off before the back-light turns off, the display may momentarily become white.
- (3) In case of V_{DD} = off level, please keep the level of input signals on the low or keep a high impedance.
- (4) T4 should be measured after the module has been fully discharged between power off and on period.
- (5) Interface signal shall not be kept at high impedance when the power is on.

Samsung Secret

7. MECHANICAL OUTLINE DIMENSION

Approval

[Refer to the next page]

www.panelook.com

Samsung Secret

Doc.No.

LTN141AT15-B

Rev.No

04-A00-G-110209

Page

21 / 27

NO	PART NAME	CODE NO	SPECIFICATION	QTY	ENTER	REMARK
1	LTM141T15					

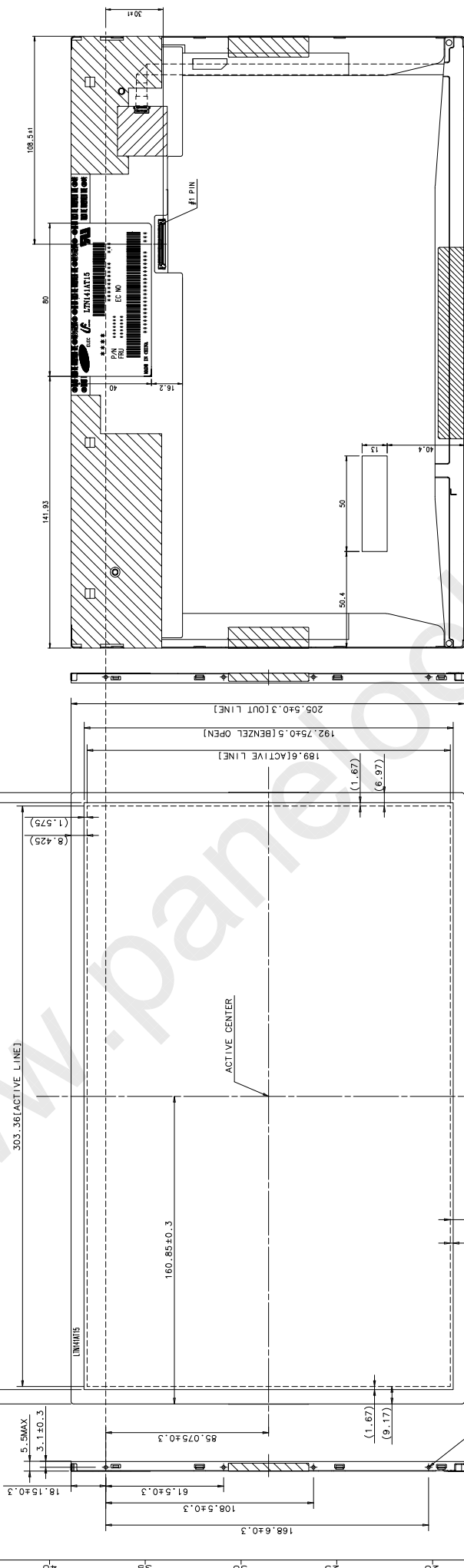
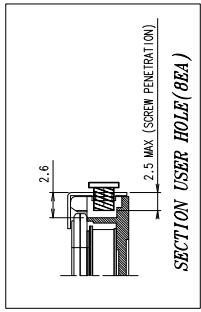

- * NOTE
- INPUT SIGNAL INTERFACE CONNECTOR TO BE SPECIFIED AS BELOW.
 - PART NO./MAKER : 20455-040E71-PEX
 - CALIFERS MEASURING FORCE : 750 ± 250 gf
 - USER HOLE TORQUE SPEC : 2.5kgfcm MAX (5 TIMES)
 - WEIGHT SPEC : 410 MAX

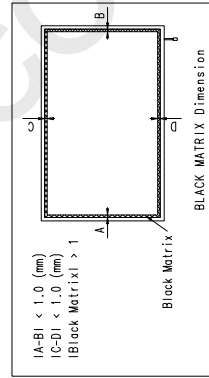

REV.	DATE	DESCRIPTION OF REVISION	APP'D BY	CHK'D BY	MODEL NAME	REASON	DRW'D BY
1					LTM141T15		

UNIT	SCALE	DRAWN BY	DESIGN BY	CHK'D BY	APP'D BY	MODEL NAME	REASON	DRW'D BY
mm	1/1	C.H.KANG	H.S.CHUN	H.S.CHUN	H.S.CHUN	LTM141T15		

REV.	DATE	DESCRIPTION OF REVISION	APP'D BY	CHK'D BY	MODEL NAME	REASON	DRW'D BY
1					LTM141T15		

SHEET	NO	TOTAL SHEETS	DATE	SCALE	UNIT	MODEL NAME	REASON	DRW'D BY
1	1	1		1/1	mm	LTM141T15		

REV.	DATE	DESCRIPTION OF REVISION	APP'D BY	CHK'D BY	MODEL NAME	REASON	DRW'D BY
1					LTM141T15		

8. PACKING

Approval

1. CARTON (Internal Package)

(1) Packing Form

Corrugated Cardboard box and Corrupad form as shock absorber

(2) Packing Method

TBD

Samsung Secret

(3)Packing Material

No	Part name	Quantity
1	Static electric protective sack	10
2	Packing case (Inner box) included shock absorber	1 set
3	Pictorial marking	2 pcs
4	Carton	1 set

Approval

9. MARKINGS & OTHERS

A nameplate bearing followed by is affixed to a shipped product at the specified location on each product.

- (1)Parts number : LTN141AT15-B
 (2)Revision : One letter
 (3)Control code : One letter
 (4)Lot number : X X X XXX XX XX

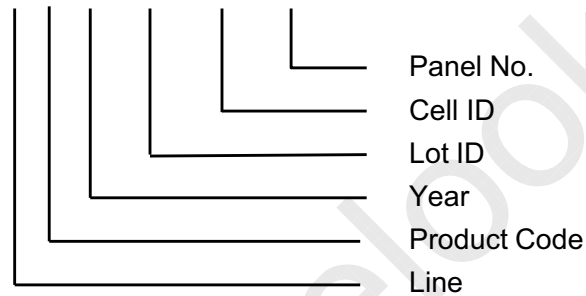

NOTE 1). This code indicating year is omitted in the products of SESL site.

(5) Product Label Definition

TBD

Samsung Secret

Approval

(6) High voltage caution label

This HIGH VOLTAGE CAUTION is carved in mold frame

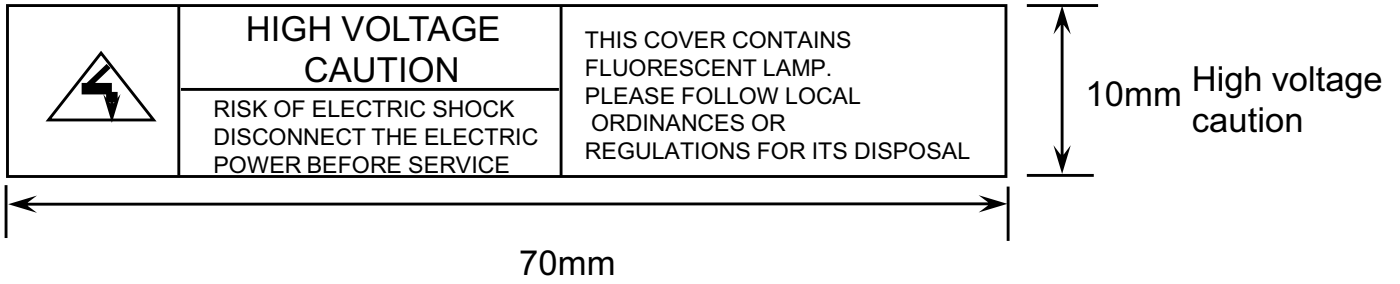

(7) Packing small box attach

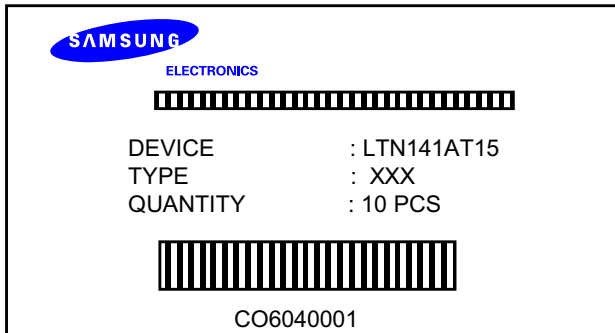
**Samsung Secret**

10. GENERAL PRECAUTIONS

1. Handling

- (a) When the module is assembled, It should be attached to the system firmly using every mounting holes. Be careful not to twist and bend the modules.
- (b) Refrain from strong mechanical shock and / or any force to the module. In addition to damage, this may cause improper operation or damage to the module and LED back-light.
- (c) Note that polarizers are very fragile and could be easily damaged. Do not press or scratch the surface harder than a HB pencil lead.
- (d) Wipe off water droplets or oil immediately. If you leave the droplets for a long time, Staining and discoloration may occur.
- (e) If the surface of the polarizer is dirty, clean it using some absorbent cotton or soft cloth.
- (f) The desirable cleaners are water, IPA (Isopropyl Alcohol) or Hexane. Do not use Ketone type materials(ex. Acetone), Ethyl alcohol, Toluene, Ethyl acid or Methyl chloride. It might permanent damage to the polarizer due to chemical reaction.
- (g) If the liquid crystal material leaks from the panel, it should be kept away from the eyes or mouth . In case of contact with hands, legs or clothes, it must be washed away thoroughly with soap.
- (h) Protect the module from static , it may cause damage to the C-MOS Gate Array IC.
- (i) Use fingerstalls with soft gloves in order to keep display clean during the incoming inspection and assembly process.
- (j) Do not disassemble the module.
- (k) Do not adjust the variable resistor which is located on the back side.
- (l) Protection film for polarizer on the module shall be slowly peeled off just before use so that the electrostatic charge can be minimized.
- (m) Pins of I/F connector shall not be touched directly with bare hands.

Samsung Secret

2. STORAGE

Approval

- (a) Do not leave the module in high temperature, and high humidity for a long time.
It is highly recommended to store the module with temperature from 5 to 40 °C and relative humidity of less than 70%.
- (b) Do not store the TFT-LCD module in direct sunlight.
- (c) The module shall be stored in a dark place. It is prohibited to apply sunlight or fluorescent light during the store.
- (d) Storage period is recommended not to exceed 1 year.

3. OPERATION

- (a) Do not connect, disconnect the module in the " Power On" condition.
- (b) Power supply should always be turned on/off by following item 6.3 " Power on/off sequence ".
- (c) Module has high frequency circuits. Sufficient suppression to the electromagnetic interference shall be done by system manufacturers. Grounding and shielding methods may be important to minimize the interference.
- (d) The FPC cable between the LED chips and its converter power supply shall be a minimized length and be connected directly . The longer cable between the back-light and the converter may cause lower luminance of light source (LED).
- (e) The standard limited warranty is only applicable when the module is used for general notebook applications. If used for purposes other than as specified, SEC is not to be held reliable for the defective operations. It is strongly recommended to contact SEC to find out fitness for a particular purpose.

4. OTHERS

- (a) Ultra-violet ray filter is necessary for outdoor operation.
- (b) Avoid condensation of water. It may result in improper operation or disconnection of electrode.
- (c) Do not exceed the absolute maximum rating value. (the supply voltage variation, input voltage variation, variation in part contents and environmental temperature, so on)
Otherwise the module may be damaged.
- (d) If the module displays the same pattern continuously for a long period of time, it can be the situation when the image "sticks" to the screen.
- (e) This module has its circuitry PCB's on the rear side and should be handled carefully in order not to be stressed.

Samsung Secret