

SAMSUNG**ELECTRONICS**

Approval



TO : NEC

DATE : Oct. 03th, 2007**SAMSUNG TFT-LCD****MODEL NO. : LTN154AT08-001**

NOTE : Surface type [**Glare**]
Green product (Complied with RoHS requirement)

Any Modification of Spec is not allowed without SEC' permission

APPROVED BY :

K. H. Shin

PREPARED BY :

LCD Mobile Development group 1

SAMSUNG ELECTRONICS CO., LTD.**SEC Secret**

Doc.No.	LTN154AT08-001	Rev.No	04-A00-G-071003	Page	1 / 31
---------	----------------	--------	-----------------	------	--------

Approval

CONTENTS

Revision History	----- (3)
General Description	----- (4)
1. Absolute Maximum Ratings	----- (5)
1.1 Absolute Ratings of Environment	
1.2 Electrical Absolute Ratings	
2. Optical Characteristics	----- (7)
3. Electrical Characteristics	----- (10)
3.1 TFT LCD Module	
3.2 Backlight Unit	
4. Block Diagram	----- (13)
4.1 TFT LCD Module	
4.2 Backlight Unit	
5. Input Terminal Pin Assignment	----- (15)
5.1 Input Signal & Power	
5.2 LVDS Interface	
5.3 Backlight Unit	
5.4 Timing Diagrams of LVDS For Transmitting	
5.5 Input Signals, Basic Display Colors and Gray Scale of Each Color.	
5.6 Pixel format	
6. Interface Timing	----- (20)
6.1 Timing Parameters	
6.2 Timing Diagrams of interface Signal	
6.3 Power ON/OFF Sequence	
7. Outline Dimension	----- (22)
8. Packing	----- (24)
9. Marking & Others	----- (25)
10. General Precaution	----- (27)
11. EEDID	----- (29)

SEC Secret

Doc.No.	LTN154AT08-001	Rev.No	04-A00-G-071003	Page	2 / 31
----------------	----------------	---------------	-----------------	-------------	--------

**REVISION HISTORY**

Approval

Date	Rev. No.	Page	Summary
Oct. 03. 2007	A00	All	- LTN154AT08-001 model specification was issued first.

SEC Secret

Doc.No.	LTN154AT08-001	Rev.No	04-A00-G-071003	Page	3 / 31
----------------	----------------	---------------	-----------------	-------------	--------

GENERAL DESCRIPTION

Approval

DESCRIPTION

LTN154AT08 is a color active matrix TFT (Thin Film Transistor) liquid crystal display (LCD) that uses amorphous silicon TFT as a switching devices. This model is composed of a TFT LCD panel, a driver circuit, and back-light system. The resolution of a 15.4 " contains 1280 x 800 pixels and can display up to 262,144colors. 6 o'clock direction is the optimum viewing angle.

FEATURES

- Ultra High Luminance with 2-CCFL
- High Color Gamut (Typical 72%)
- Normal viewing angle (H90/ V 50)
- High contrast ratio (Ultra fine & shine view)
- WXGA (1280x800 pixels) resolution
- Low power consumption
- DE (Data enable) only mode.
- 3.3V LVDS (FPD Link) Interface with 1 pixel / clock
- On board EDID chip
- RoHS Compliance Product

APPLICATIONS

- Multimedia Notebook PC
- Display terminals for AV application products
- If the usage of this product is not for PC application, but for others, please contact SEC.

GENERAL INFORMATION

Item	Specification	Unit	Note
Display area	331.2(H) X 207.0(V) (15.4"diagonal)	mm	
Driver element	a-si TFT active matrix		
Display colors	262,144		
Number of pixel	1280 x RGB x 800	pixel	16 : 10
Pixel arrangement	RGB vertical stripe		
Pixel pitch	0.25875(H) x 0.25875(V)	mm	
Display Mode	Normally white		
Surface treatment	Haze 0(Glare), Hardness 3H, Reflection ratio : Max.2%		

SEC Secret

Doc.No.	LTN154AT08-001	Rev.No	04-A00-G-071003	Page	4 / 31
----------------	----------------	---------------	-----------------	-------------	--------

Approval

Mechanical Information

ITEM		MIN	TYP	MAX	NOTE
Module size (mm)	Horizontal (H)	343.5	344.0	344.5	
	Vertical (V)	224.5	225.0	225.5	
	Thickness (T)	-	6.7	7.0	(1)
Weight (g)		-	600	620	

Note (1) Measurement condition of outline dimension
 . Equipment : Vernier Calipers
 . Push Force : 500g · f (minimum)

1. ABSOLUTE MAXIMUM RATINGS**1.1 ENVIRONMENTAL ABSOLUTE RATINGS**

Item	Symbol	Min.	Max.	Unit	Note
Storage temperate	TSTG	-20	60	°C	(1)
Operating temperate (Temperature of glass surface)	TOPR	0	50	°C	(1)
Shock (non-operating)	Snop	-	240	G	(2),(4)
Vibration (non-operating)	Vnop	-	2.41	G	(3),(4)

Note (1) Temperature and relative humidity range are shown in the figure below.
 95 % RH Max. ($40\text{ °C} \geq T_a$)
 Maximum wet - bulb temperature at 39 °C or less. ($T_a > 40\text{ °C}$) No condensation

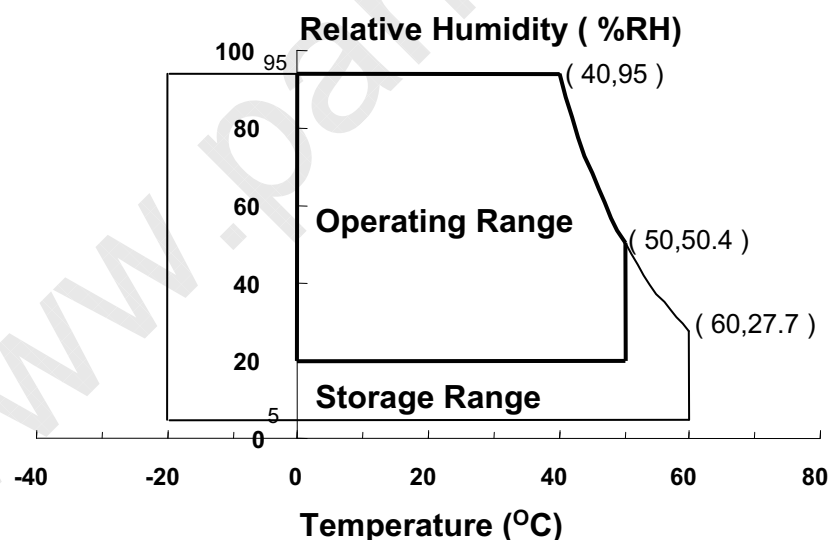

- (2) 2ms, half sine wave, one time for $\pm X, \pm Y, \pm Z$.
 (3) 5 - 500 Hz, random vibration, 30min for X, Y, Z.
 (4) At testing Vibration and Shock, the fixture in holding the Module to be tested have to be hard and rigid enough so that the Module would not be twisted or bent by the fixture.
 (5) If this product is used for extended time excessively or exposed to high temperatures for extended time, there is a possibility of wide viewing angle film damage which could affect visual characteristics.

SEC Secret

Doc.No.	LTN154AT08-001	Rev.No	04-A00-G-071003	Page	5 / 31
---------	----------------	--------	-----------------	------	--------

Approval

1.2 ELECTRICAL ABSOLUTE RATINGS

(1) TFT LCD MODULE

 $V_{DD} = 3.3V, V_{SS} = GND = 0V$

Item	Symbol	Min.	Max.	Unit	Note
Power Supply Voltage	V_{DD}	$V_{DD} - 0.3$	$V_{DD} + 0.3$	V	(1)
Logic Input Voltage	V_{DD}	$V_{DD} - 0.3$	$V_{DD} + 0.3$	V	(1)

Note (1) Within T_a ($25 \pm 2^\circ C$)

(2) BACK-LIGHT UNIT

 $T_a = 25 \pm 2^\circ C$

Item	Symbol	Min.	Max.	Unit	Note
Lamp Current	I_L	3.0	6.5	mArms	(1)
Lamp frequency	F_L	50	65	kHz	(1)

Note 1) Permanent damage to the device may occur if maximum values are exceeded

Functional operation should be restricted to the conditions described under normal operating conditions.

SEC Secret

Doc.No.	LTN154AT08-001	Rev.No	04-A00-G-071003	Page	6 / 31
---------	----------------	--------	-----------------	------	--------

Approval

2. OPTICAL CHARACTERISTICS

The following items are measured under stable conditions. The optical characteristics should be measured in a dark room or equivalent state with the methods shown in Note (5).
Measuring equipment : TOPCON SR-3

* Ta = 25 ± 2 °C, V_{DD}=3.3V, fv= 60Hz, f_{DCLK}=68.94MHz, (I_L= 6.0 mA)

Item	Symbol	Condition	Min.	Typ.	Max	Unit	Note
Contrast Ratio (5 points)	CR			600	-	-	(1), (2), (5)
Response Time at Ta (Rising + Falling)	T _{RT}		-	16	-		
Luminance of White (Center point)	Y _{L,AVE}		260	300	-	cd/m ²	I _L =6.0mA (1), (4)
Color Chromaticity (CIE)	Red	R _X	0.614	0.644	0.674	-	(1), (5) SR-3
		R _Y	0.305	0.335	0.365		
	Green	G _X	0.258	0.288	0.318		
		G _Y	0.568	0.598	0.628		
	Blue	B _X	0.114	0.144	0.174		
		B _Y	0.043	0.073	0.103		
	White	W _X	0.283	0.313	0.343		
		W _Y	0.299	0.329	0.359		
Viewing Angle	Hor.	θ _L	40	45	-	Degrees	
		θ _H	40	45	-		
	Ver.	φ _H	10	15	-		
		φ _L	30	35	-		
13 Points White Variation	δ _L			1.8		(6)	

SEC Secret

Doc.No.	LTN154AT08-001	Rev.No	04-A00-G-071003	Page	7 / 31
---------	----------------	--------	-----------------	------	--------

Approval

Note 1) Definition of Viewing Angle : Viewing angle range($10 \leq C/R$)

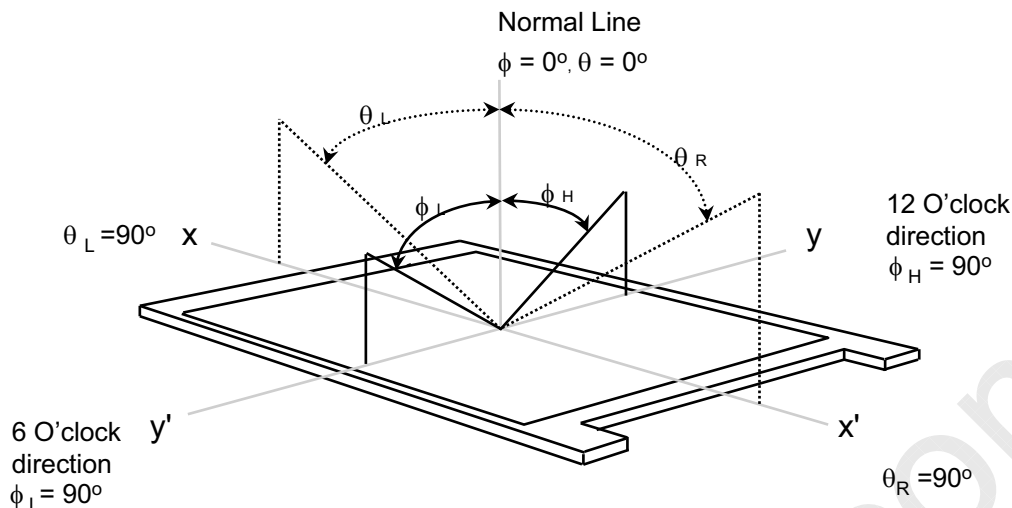

Note 2) Definition of Contrast Ratio (CR) : Ratio of gray max (Gmax) ,gray min (Gmin) at 5 points(4, 5, 7, 9, 10)

$$CR = \frac{CR(4) + CR(5) + CR(7) + CR(9) + CR(10)}{5}$$

Points : (4) , (5) , (7) , (9) , (10) at the figure of Note (6).

Note 3) Definition of Response time :

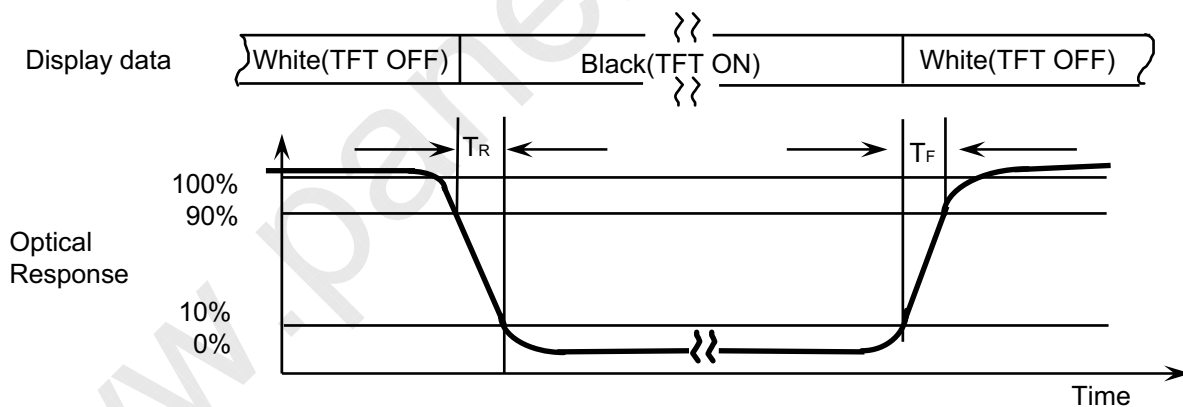

Note 4) Definition of Luminance of White : measure the luminance of white at center point.

Luminance of White ($Y_{L,AVE}$)

$$Y_{L,AVE} = Y_{L7}$$

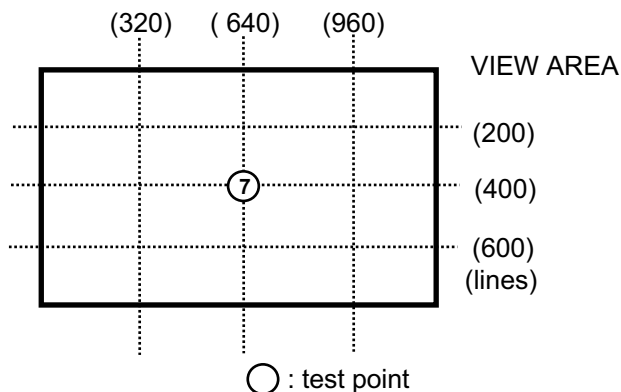

SEC Secret

Approval

Note 5) After stabilizing and leaving the panel alone at a given temperature for 30 min , the measurement should be executed. Measurement should be executed in a stable, windless, and dark room. 30 min after lighting the backlight. This should be measured in the center of screen.
 Lamp current : 6.0mA (Inverter : SIC-1801)
 Environment condition : Ta = 25 ± 2 °C

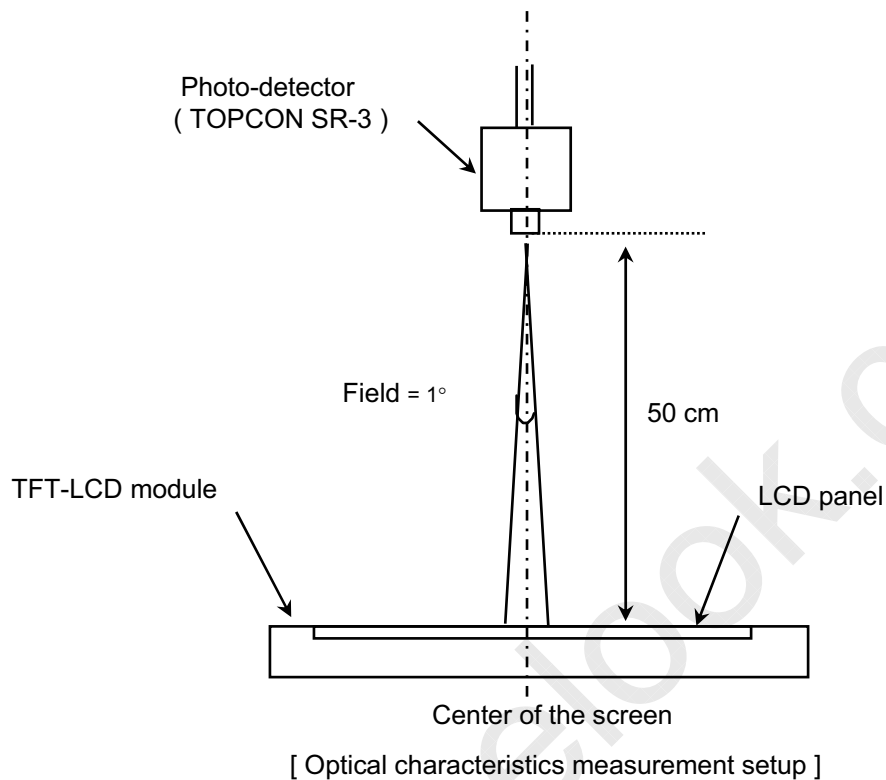

Note 6) Definition of 13 points white variation (δL), [① ~ ⑬]

$$\delta L = \frac{\text{Maximum luminance of 13 points}}{\text{Minimum luminance of 13 points}}$$

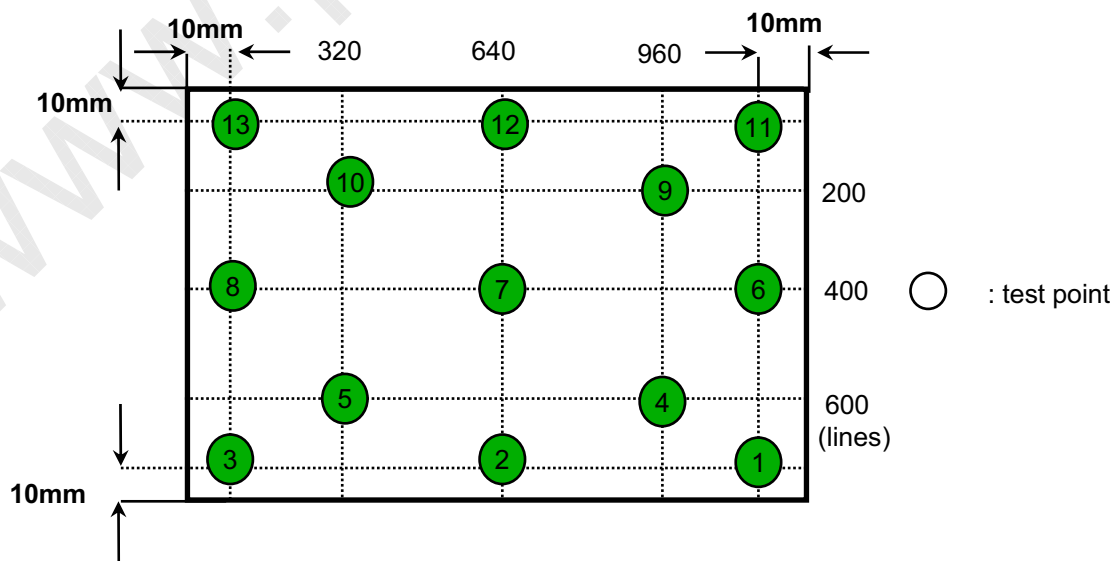

SEC Secret

Doc.No.	LTN154AT08-001	Rev.No	04-A00-G-071003	Page	9 / 31
---------	----------------	--------	-----------------	------	--------

3. ELECTRICAL CHARACTERISTICS

Approval

3.1 TFT LCD MODULE

Ta= 25 ± 2 °C

Item	Symbol	Min.	Typ.	Max.	Unit	Note	
Voltage of Power Supply	V _{DD}	3.0	3.3	3.6	V		
Differential Input Voltage for LVDS Receiver Threshold	High	V _{IH}	-	-	+100	mV	V _{CM} = +1.2V
	Low	V _{IL}	-100	-	-	mV	
Vsync Frequency	f _v	-	60	-	Hz		
Hsync Frequency	f _H	-	48.96	-	KHz		
Main Frequency	f _{DCLK}	63.84	68.94	74.97	MHz		
Rush Current	I _{RUSH}	-	-	1.5	A	(4)	
Current of Power Supply	White	I _{DD}	-	320	-	mA	(2),(3)*a
	Mosaic		-	410	-	mA	(2),(3)*b
	1Dot Ver		-	430	-	mA	(2),(3)*c
	2Dot Max		-	470	530	mA	(2),(3)*d

Note (1) Display data pins and timing signal pins should be connected.(GND=0V)

(2) f_v=60Hz, f_{DCLK} =68.94MHZ, V_{dd} = 3.3V , DC Current.

(3) Power dissipation pattern

*a) White Pattern

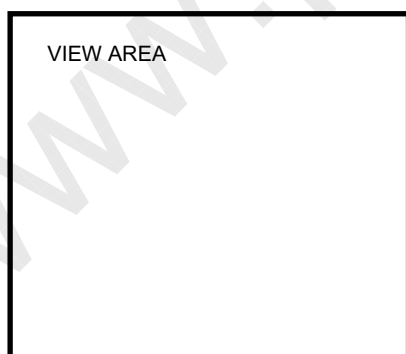

*b) Mosaic Pattern

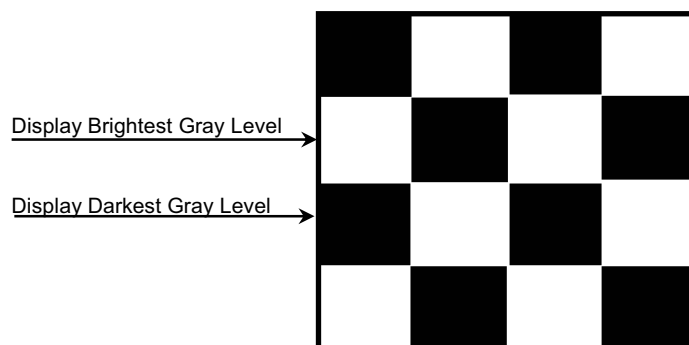

SEC Secret

Doc.No.	LTN154AT08-001	Rev.No	04-A00-G-071003	Page	10 / 31
---------	----------------	--------	-----------------	------	---------

Approval

*c) Maximum power pattern : 1 dot vertical

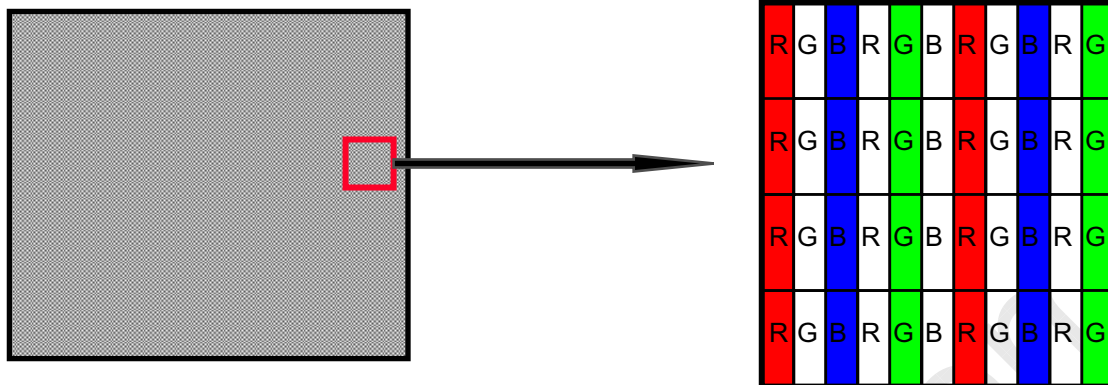

*d) 2dot max

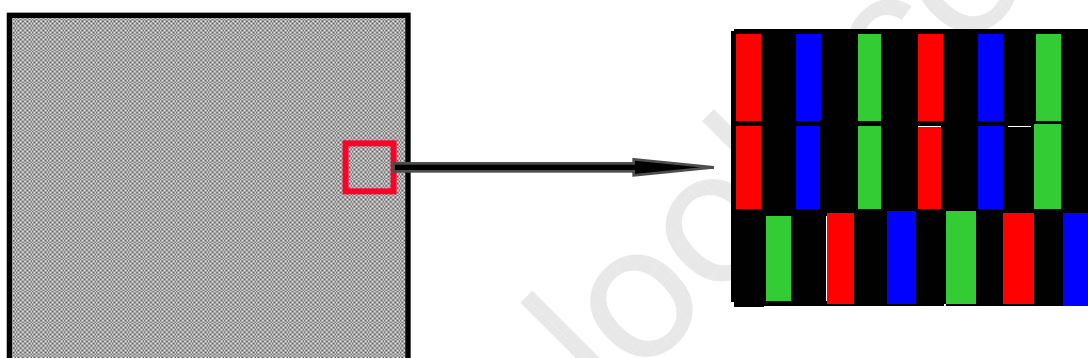

4) Rush current measurement condition

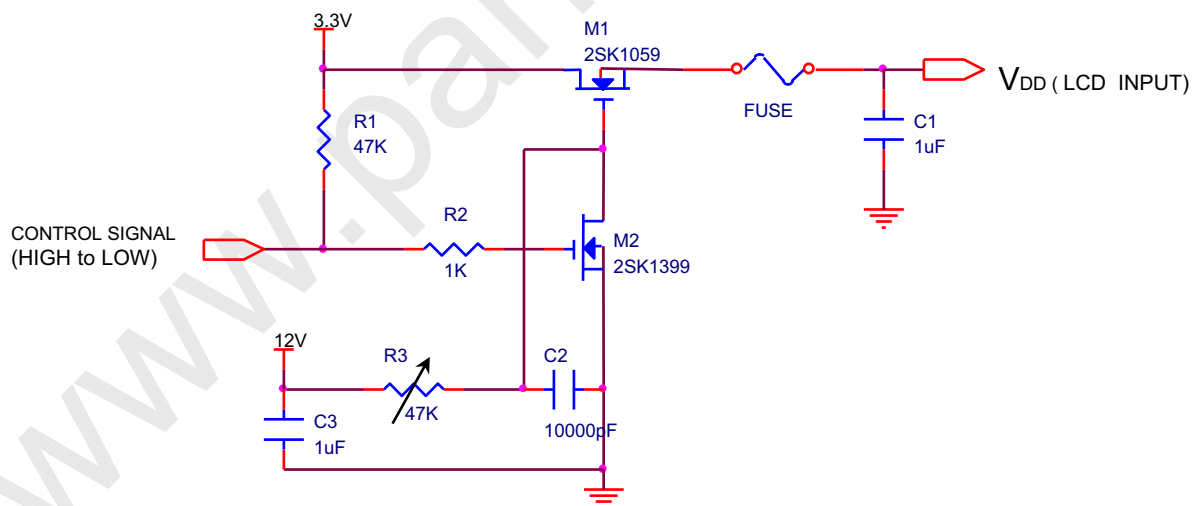

V_{DD} rising time is 470us

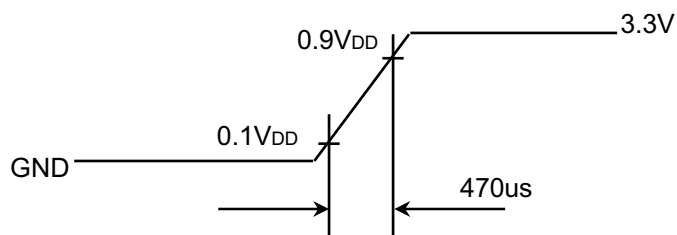

SEC Secret

Doc.No.	LTN154AT08-001	Rev.No	04-A00-G-071003	Page	11 / 31
---------	----------------	--------	-----------------	------	---------

3.2 BACK-LIGHT UNIT

Approval

The backlight system is an edge - lighting type with dual CCFL (Cold Cathode Fluorescent Lamp).

The characteristics of a single lamp are shown in the following tables.

CCFL P/N : SS20D3370N6575C2682450S, Sanken

INVERTER : SIC-1801

Ta= 25 ± 2 °C

Item	Symbol	Min.	Typ.	Max.	Unit	Note
Lamp Current	I_L	3.0	6.0	6.5	mArms	(1)
Lamp Voltage	V_L	-	700/CCFL	-	Vrms	$I_L=6.0mA$
Frequency	f_L	50	60	65	KHz	(2)
Power Consumption	P_L		4.2/CCFL		W	(3), $I_L=6.0mA$
Operating Life Time	Hr	10,000			Hour	(4), $I_L=6.5mA$
Startup Voltage	V_s	-	-	1180	Vrms	25°C, (5)
				1300	Vrms	0°C, (5)
Lamp startup time		-	-	1.0	sec	(5)

Note) The waveform of the inverter output voltage must be area symmetric and the design of the inverter must have specifications for the modularized lamp.

The performance of the back-light, for example life time or brightness, is much influenced by the characteristics of the DC-AC inverter for the lamp. So all the parameters of an inverter should be carefully designed so as not to produce too much leakage current from high-voltage output of the inverter.

When you design or order the inverter, please make sure that a poor lighting caused by the mismatch of the back-light and the inverter(miss lighting, flicker, etc.) never occurs. When you confirm it, the module should be operated in the same condition as it is installed in your instrument.

Note (1) Lamp current is measured with a high frequency current meter as shown below.

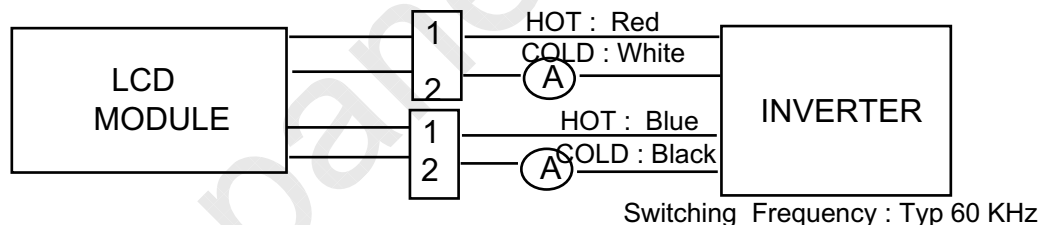

(2) Lamp frequency may produce interference with horizontal synchronous frequency and this may cause line flow on the display. Therefore lamp frequency should be detached from the horizontal synchronous frequency and its harmonics as far as possible in order to avoid interference.

(3) refer to $I_L \times V_L$ to calculate.

(4) Life time (Hr) of a lamp can be defined as the time in which it continues to operate under the condition Ta= 25 ± 2 °C and $I_L = 6.5$ mArms until one of the following event occurs.

1. When the brightness becomes 50% or lower than the original.
2. When the Effective ignition length becomes 80% or lower than the original value.

(Effective ignition length is defined as an area that has less than 70% brightness compared to the brightness in the center point.)

(5) The inverter open voltage - this voltage should be measured behind ballast capacitor- has to be larger than the lamp startup voltage. Otherwise, backlight may have blinking for a moment after being turned on, or not be turned on. If an inverter has shutdown function, it should keep its open voltage for longer than 1 second even if lamp connector is open. Also, to prevent over current of one side lamp, shut down function should be designed in the customer's inverter.

(6) SEC checked and found that no waterfall symptom between 170 ~ 230Hz.

SEC Secret

Doc.No.	LTN154AT08-001	Rev.No	04-A00-G-071003	Page	12 / 31
---------	----------------	--------	-----------------	------	---------

Approval

4. BLOCK DIAGRAM

4.1 TFT LCD Module

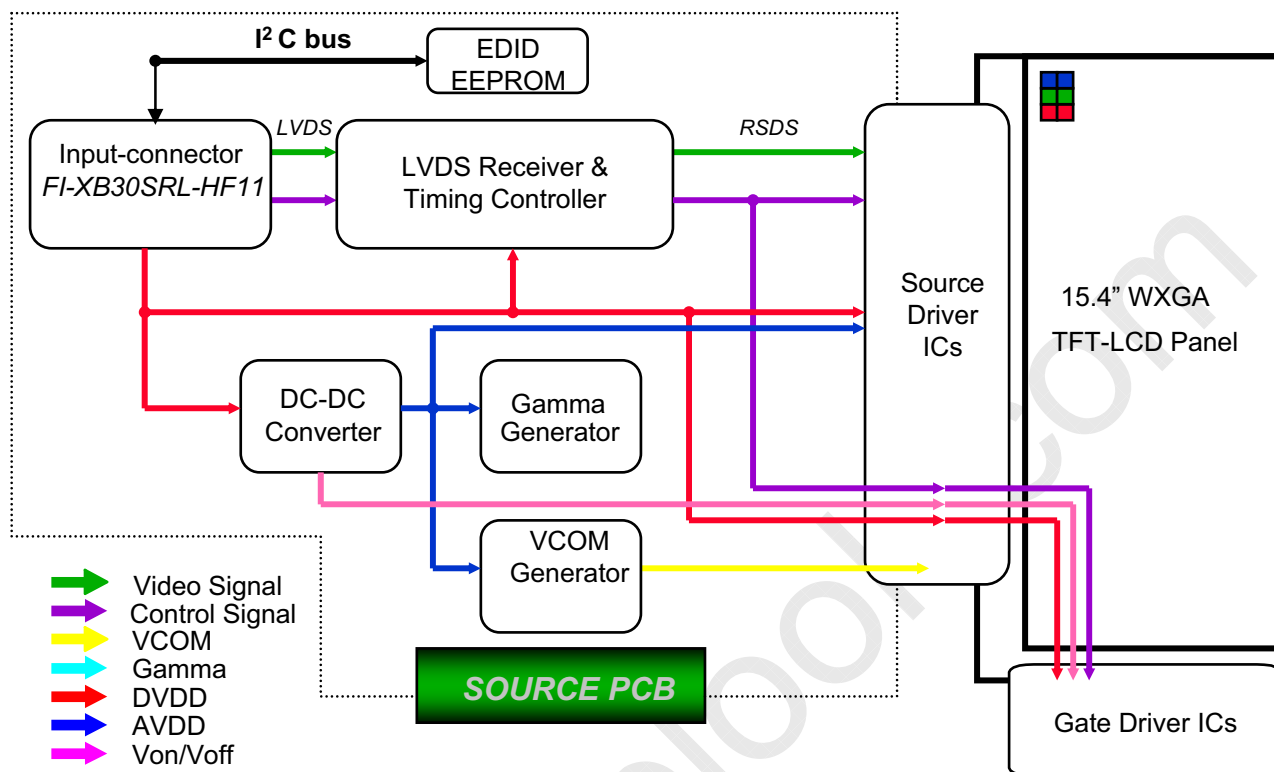

4.2 BACK-LIGHT UNIT (2lamp, Y-stack structure)

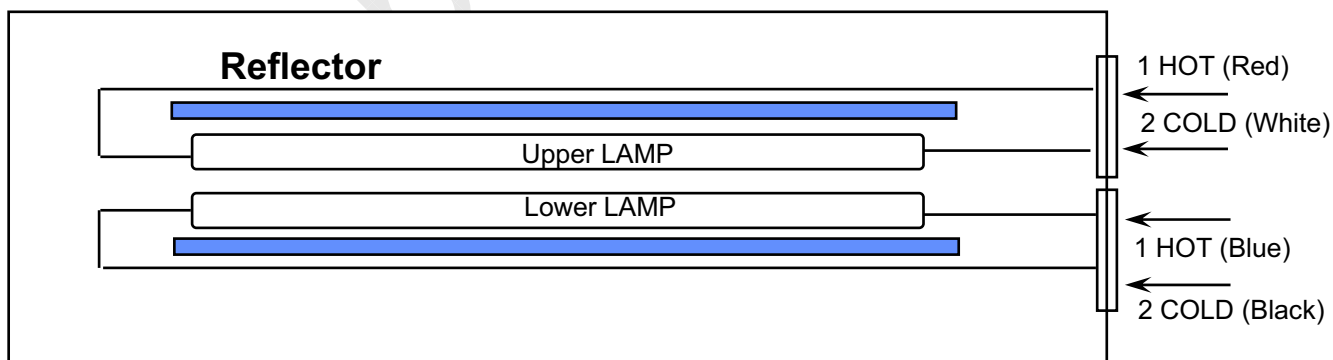

Note) SEC would like to recommend the unbalance ratio less than 10%.
 And crest factor needs to be less than 1.414 ± 15%.

SEC Secret

Doc.No.	LTN154AT08-001	Rev.No	04-A00-G-071003	Page	13 / 31
---------	----------------	--------	-----------------	------	---------

- Reference note of lighting waveform and drive frequency

■点灯波形と駆動周波数

点灯波形が非対称の場合、水銀の片寄りまたはArガスの消耗が生じます。

このため点灯波形は、アンバランス度10%以下、波高率 $\sqrt{2} \pm 15\%$ 以内での使用を推奨いたします。

点灯波形の非対称は、CCFL単体ではなくLCDモジュールとして駆動する場合に顕著になります。実機での確認をお願い致します。サンケン電気製インバータは、この問題を考慮して設計しております。

■ Lighting waveform and drive frequency:

In case of the lighting waveform being asymmetric, polarization of mercury or consumption of Ar gas may happen. Therefore, the lighting waveform shall be within 10% of imbalance factor and crest factor of $\sqrt{2} \pm 15\%$.

Asymmetric lighting waveform becomes significant, when driven as a LCD module rather than as an individual CCFL.

Verification is required on the actual equipment. Sanken inverter is designed in consideration of this issue.

波形の図
Waveform

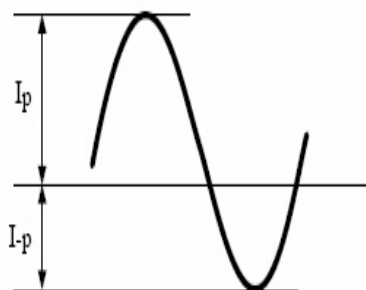

$$A: \text{Imbalance factor} = |I_p - I_{-p}| / I_{rms} \times 100 (\%)$$

$$B: \text{Crest factor} = I_p (\text{or } I_{-p}) / I_{rms}$$

I_p : High side peak value

I_{-p} : Low side peak value

I_{rms} : Root mean square value

SEC Secret

Doc.No.

LTN154AT08-001

Rev.No

04-A00-G-071003

Page

14 / 31

Approval

5. INPUT TERMINAL PIN ASSIGNMENT

5.1. Input Signal & Power LVDS, Connector : UJU, IS100-L30R-C15
Mating Connector: JAE, FI-X30M

No.	Symbol	Function	Polarity	Remarks
1	VSS	Ground		
2	VDD	POWER SUPPLY +3.3V		
3	VDD	POWER SUPPLY +3.3V		
4	VEEDID	DDC 3.3V Power		
5	DVR_CLK	I2C Control signal		
6	CLKEDID	DDC Clock		
7	DATAEDID	DDC data		
8	RxIN0-	LVDS Differential Data INPUT (R0-R5,G0)	Negative	
9	RxIN0+	LVDS Differential Data INPUT (R0-R5,G0)	Positive	
10	GND	Ground		
11	RxIN1-	LVDS Differential Data INPUT (G1-G5,B0-B1)	Negative	
12	RxIN1+	LVDS Differential Data INPUT (G1-G5,B0-B1)	Positive	
13	GND	Ground		
14	RxIN2-	LVDS Differential Data INPUT (B2-B5,Sync,DE)	Negative	
15	RxIN2+	LVDS Differential Data INPUT (B2-B5,Sync,DE)	Positive	
16	Vss	Ground		
17	ClkIN-	LVDS Differential Clock INPUT	Negative	
18	ClkIN+	LVDS Differential Clock INPUT	Positive	
19	Vss	Ground		
20	NC	No connect		
21	NC	No connect		
22	NC	No connect		
23	NC	No connect		
24	NC	No connect		
25	NC	No connect		
26	NC	No connect		
27	NC	No connect		
28	NC	No connect		
29	NC	No connect		
30	NC	No connect		

SEC Secret

Doc.No.

LTN154AT08-001

Rev.No

04-A00-G-071003

Page

15 / 31

Approval

5.2 LVDS Interface : Transmitter DS90CF383 or Compatible

Pin No.	Name	RGB Signal	Pin No.	Name	RGB Signal
51	TxIN0	R0	14	TxIN14	G5
52	TxIN1	R1	15	TxIN15	B0
54	TxIN2	R2	19	TxIN18	B1
55	TxIN3	R3	20	TxIN19	B2
56	TxIN4	R4	22	TxIN20	B3
3	TxIN6	R5	23	TxIN21	B4
4	TxIN7	G0	24	TxIN22	B5
6	TxIN8	G1	27	TxIN24	Hsync
7	TxIN9	G2	28	TxIN25	Vsync
11	TxIN12	G3	30	TxIN26	DE
12	TxIN13	G4	31	TxCLKIN	Clock

LVDS INTERFACE

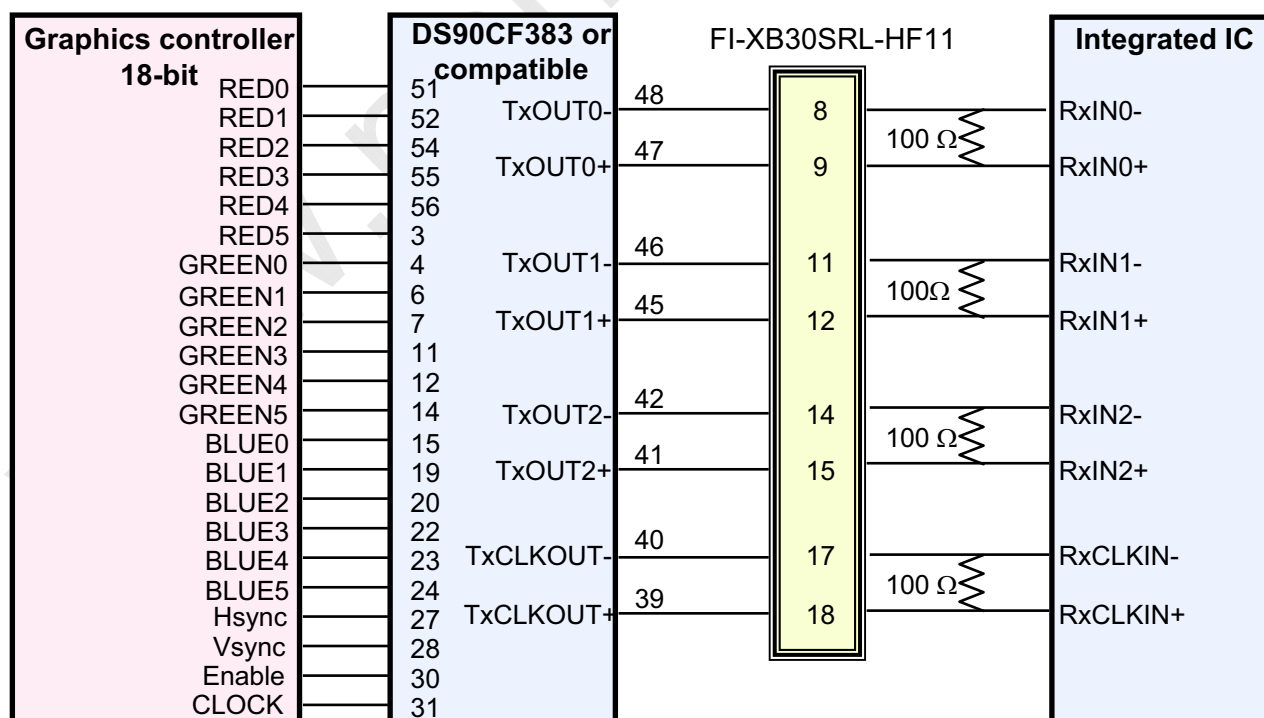

SEC Secret

Doc.No.	LTN154AT08-001	Rev.No	04-A00-G-071003	Page	16 / 31
---------	----------------	--------	-----------------	------	---------

Approval

5.3 BACK LIGHT UNIT

Connector : JST BHSR - 02VS -1 * 2pcs

Pin No.	Symbol	Color	Function
1	HOT	Blue / Red	High Voltage
2	COLD	Black/ White	Low Voltage

5.4 Timing Diagrams of LVDS For Transmission

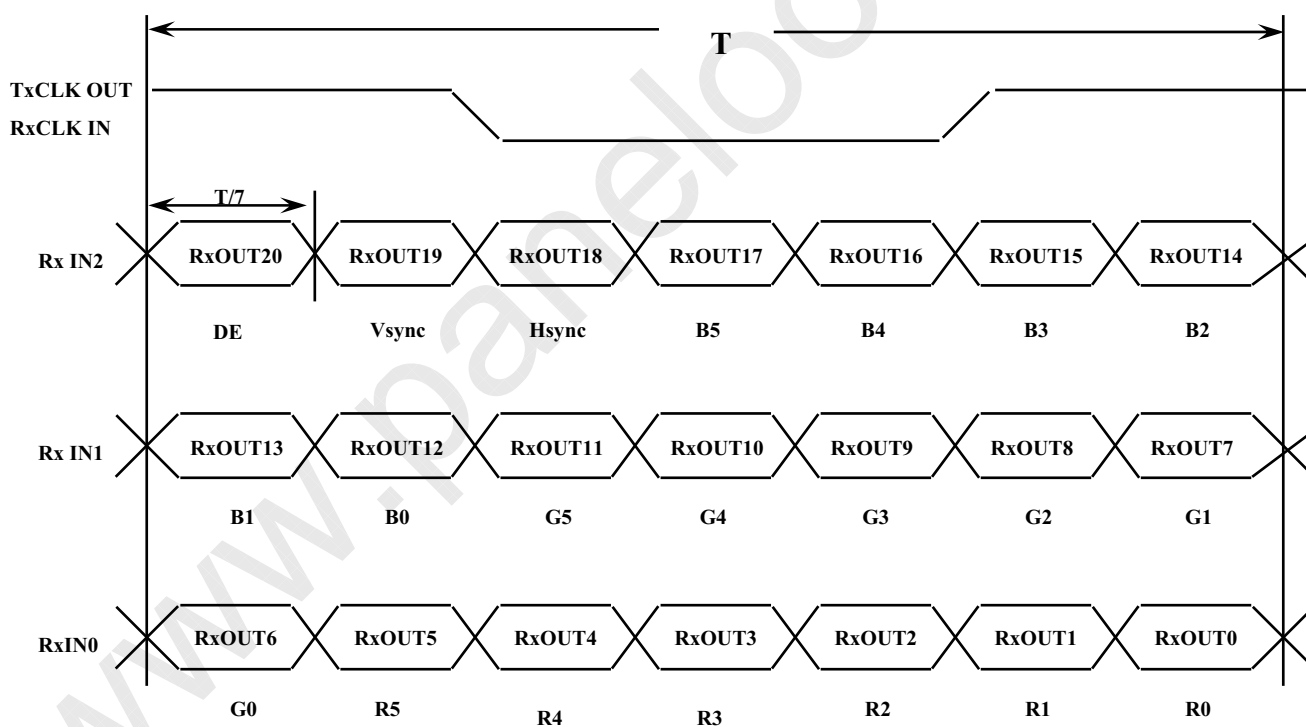

SEC Secret

Approval

5.5 Input Signal, Basic Display Colors and Gray Scale of Each Colors

COLOR	DISPLAY	DATA SIGNAL																GRAY SCALE LEVEL	
		RED					GREEN					BLUE							
		R0	R1	R2	R3	R4	R5	G0	G1	G2	G3	G4	G5	B0	B1	B2	B3		B4
BASIC COLOR	BLACK	0	0	0	0	0	0	0	0	0	0	0	0	0	0	0	0	0	-
	BLUE	0	0	0	0	0	0	0	0	0	0	0	0	1	1	1	1	1	-
	GREEN	0	0	0	0	0	0	1	1	1	1	1	1	0	0	0	0	0	-
	CYAN	0	0	0	0	0	0	1	1	1	1	1	1	1	1	1	1	1	-
	RED	1	1	1	1	1	1	0	0	0	0	0	0	0	0	0	0	0	-
	MAGENTA	1	1	1	1	1	1	0	0	0	0	0	0	1	1	1	1	1	-
	YELLOW	1	1	1	1	1	1	1	1	1	1	1	1	0	0	0	0	0	-
	WHITE	1	1	1	1	1	1	1	1	1	1	1	1	1	1	1	1	1	-
GRAY SCALE OF RED	BLACK	0	0	0	0	0	0	0	0	0	0	0	0	0	0	0	0	0	R0
	DARK ↑	1	0	0	0	0	0	0	0	0	0	0	0	0	0	0	0	0	R1
		0	1	0	0	0	0	0	0	0	0	0	0	0	0	0	0	0	R2
		:	:	:	:	:	:	:	:	:	:	:	:	:	:	:	:	:	R3~R60
		:	:	:	:	:	:	:	:	:	:	:	:	:	:	:	:	:	
	↓ LIGHT	1	0	1	1	1	1	0	0	0	0	0	0	0	0	0	0	0	R61
		0	1	1	1	1	1	0	0	0	0	0	0	0	0	0	0	0	R62
	RED	1	1	1	1	1	1	0	0	0	0	0	0	0	0	0	0	0	R63
GRAY SCALE OF GREEN	BLACK	0	0	0	0	0	0	0	0	0	0	0	0	0	0	0	0	0	G0
	DARK ↑	0	0	0	0	0	0	1	0	0	0	0	0	0	0	0	0	0	G1
		0	0	0	0	0	0	0	1	0	0	0	0	0	0	0	0	0	G2
		:	:	:	:	:	:	:	:	:	:	:	:	:	:	:	:	:	G3~G60
		:	:	:	:	:	:	:	:	:	:	:	:	:	:	:	:	:	
	↓ LIGHT	0	0	0	0	0	0	1	0	1	1	1	1	0	0	0	0	0	G61
		0	0	0	0	0	0	0	1	1	1	1	1	0	0	0	0	0	G62
	GREEN	0	0	0	0	0	0	1	1	1	1	1	1	0	0	0	0	0	G63
GRAY SCALE OF BLUE	BLACK	0	0	0	0	0	0	0	0	0	0	0	0	0	0	0	0	0	B0
	DARK ↑	0	0	0	0	0	0	0	0	0	0	0	0	1	0	0	0	0	B1
		0	0	0	0	0	0	0	0	0	0	0	0	0	1	0	0	0	B2
		:	:	:	:	:	:	:	:	:	:	:	:	:	:	:	:	:	B3~B60
		:	:	:	:	:	:	:	:	:	:	:	:	:	:	:	:	:	
	↓ LIGHT	0	0	0	0	0	0	0	0	0	0	0	0	1	0	1	1	1	B61
		0	0	0	0	0	0	0	0	0	0	0	0	0	1	1	1	1	B62
	BLUE	0	0	0	0	0	0	0	0	0	0	0	0	1	1	1	1	1	B63

Note

- (1) Definition of Gray : Rn : Red Gray, Gn : Green Gray, Bn : Blue Gray (n = Gray level)
(2) Input Signal : 0 = Low level voltage, 1 = High level voltage

SEC Secret

Doc.No.	LTN154AT08-001	Rev.No	04-A00-G-071003	Page	18 / 31
---------	----------------	--------	-----------------	------	---------

5.6 PIXEL FORMAT

Approval

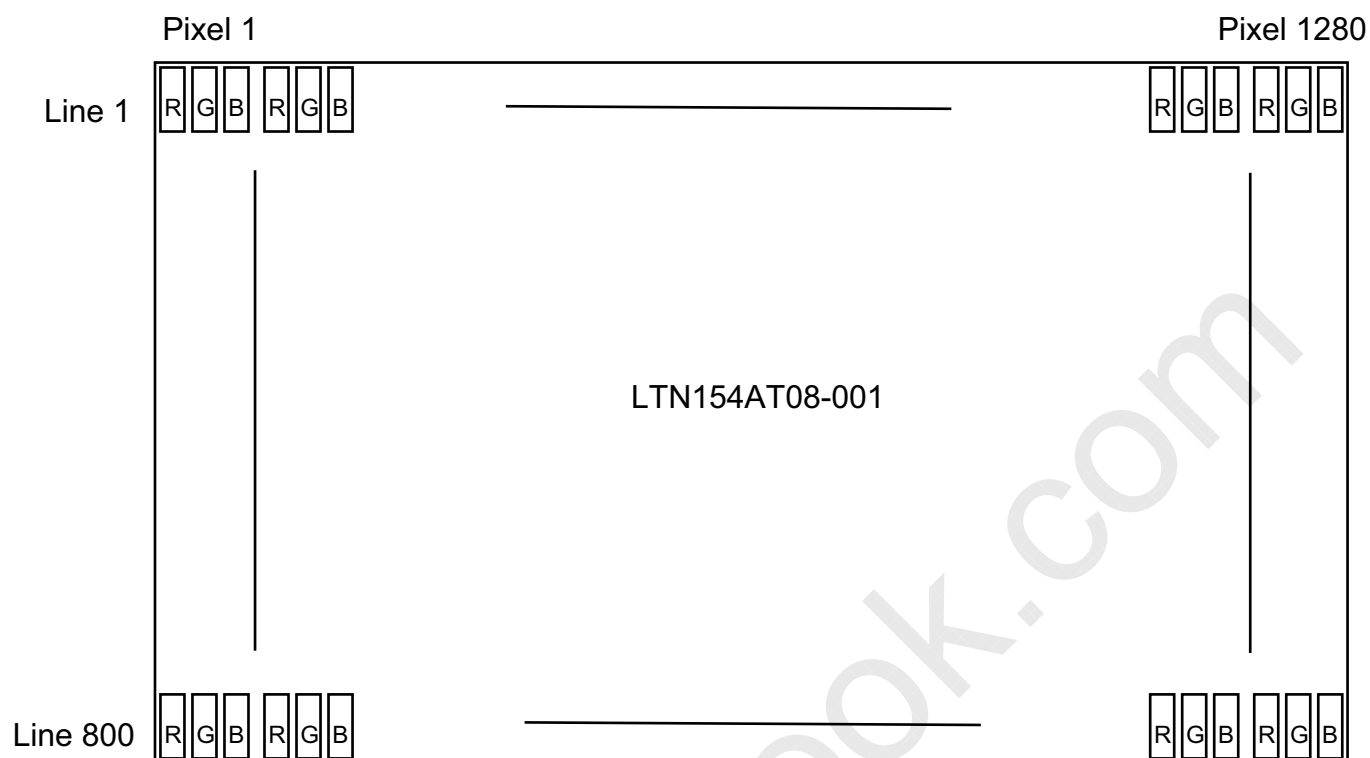

5.7 DVR Address

Slave address of DVR is 9Eh and 9Fh

- . 9Eh : reading
- . 9Fh : writing

I²C Bus Format

Start	Slave Address							W R	ACK	Data							ACK	Stop	
	1	0	0	1	1	1	1			D6	D5	D4	D3	D2	D1	D0	P		

ACK → Acknowledge

P → Program

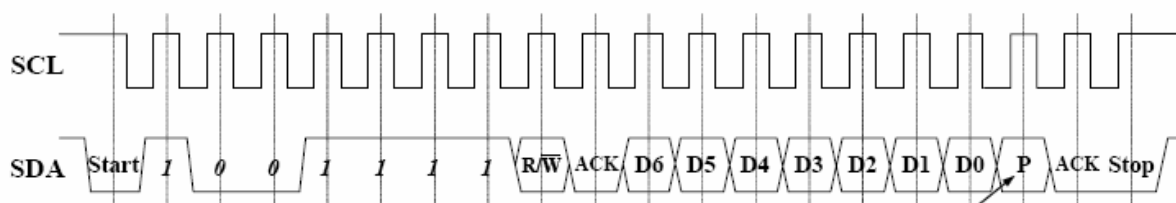

(1) When READ operation, P = don't-care.

(2) When WRITE operation,

P = 1 → Register Writing

P = 0 → E²PROM CELL Writing (Program)

[DVR Sub Address]

SEC Secret

Doc.No.	LTN154AT08-001	Rev.No	04-A00-G-071003	Page	19 / 31
---------	----------------	--------	-----------------	------	---------

Approval

6. INTERFACE TIMING

6.1 Timing Parameters

Signal	Item	Symbol	Min.	Typ.	Max.	Unit	Note
Frame Frequency	Cycle	TV	806	816	833	Lines	-
Vertical Active Display Term	Display Period	TVD	-	800	-	Lines	-
One Line Scanning Time	Cycle	TH	1350	1408	1500	Clocks	-
Horizontal Active Display Term	Display Period	THD	-	1280	-	Clocks	-

6.2 Timing diagrams of interface signal

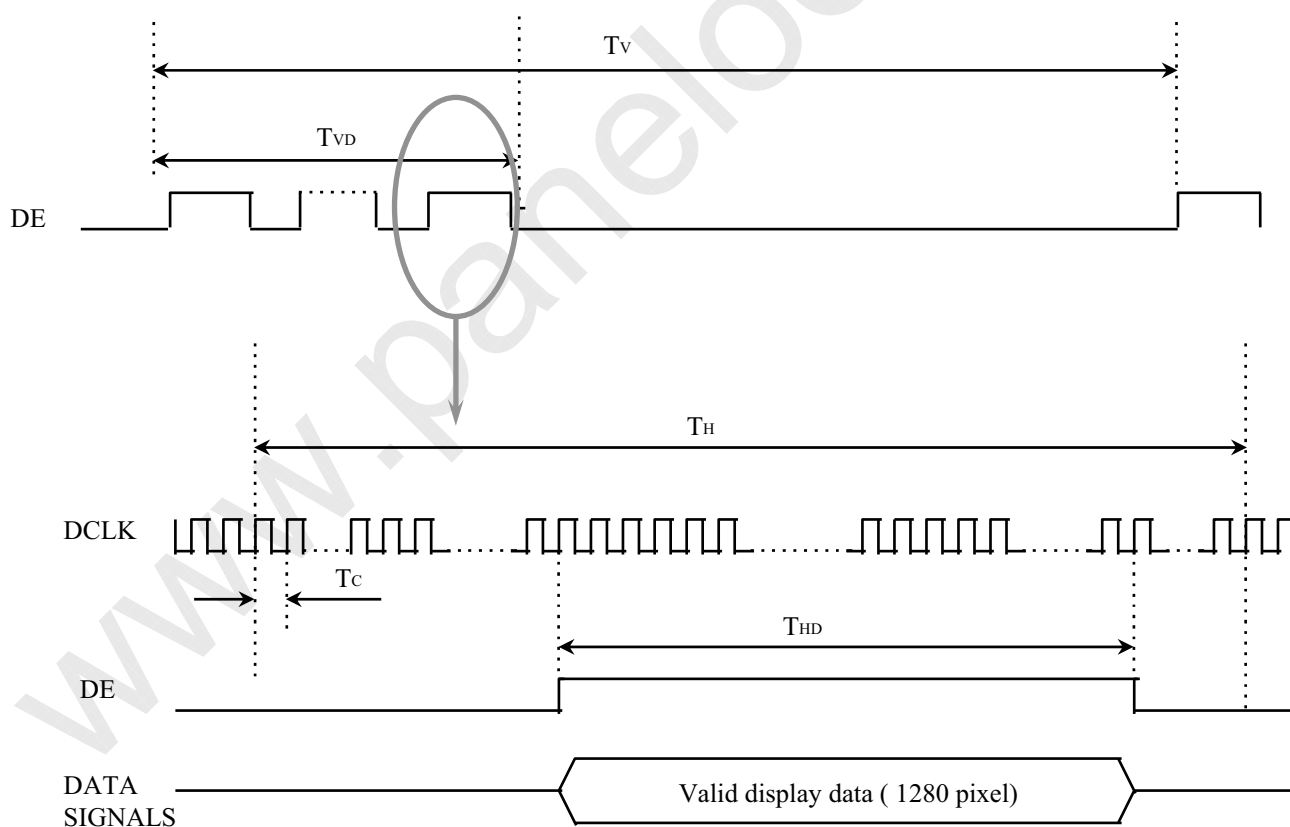

SEC Secret

Doc.No.

LTN154AT08-001

Rev.No

04-A00-G-071003

Page

20 / 31

Approval

6.3 Power ON/OFF Sequence

: To prevent a latch-up or DC operation of the LCD module, the power on/off sequence should be as the diagram below. (VESA recommendation)

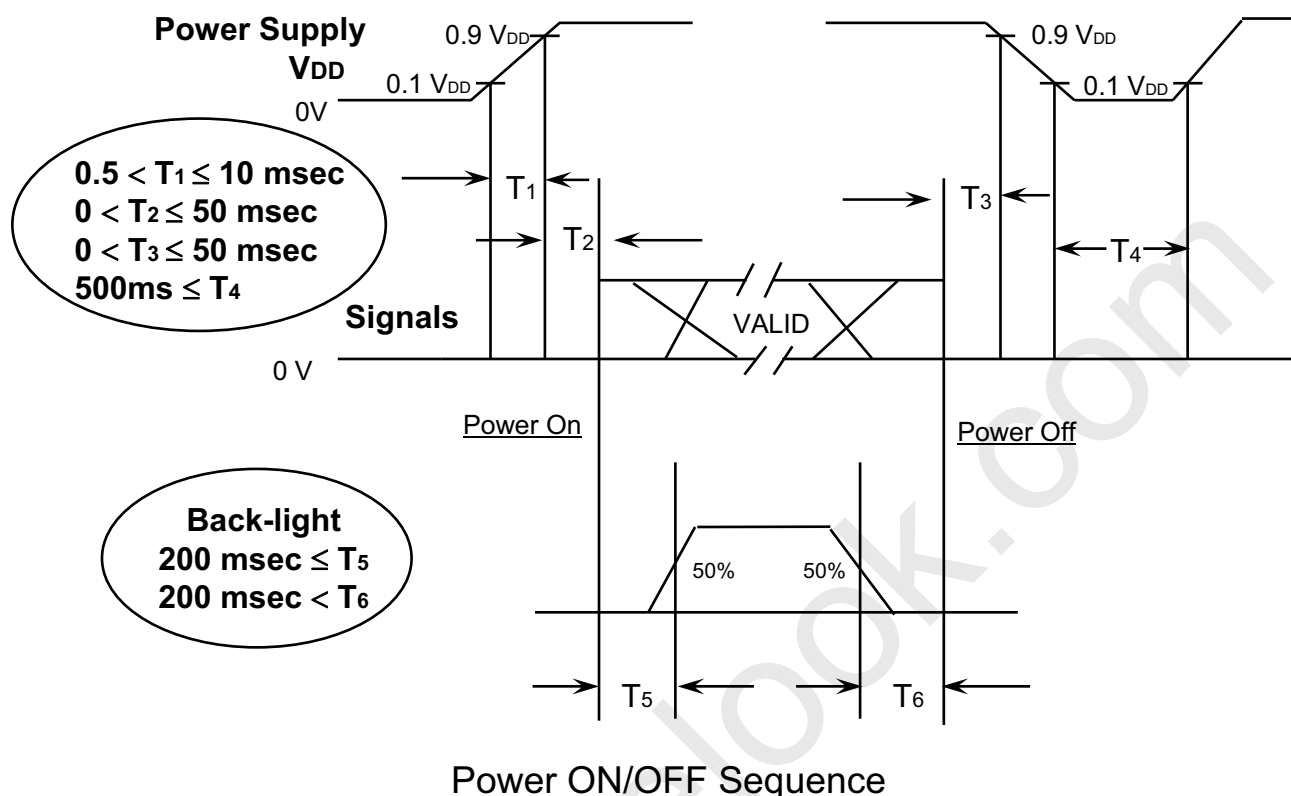

T1 : Vdd rising time from 10% to 90%

T2 : The time from Vdd to valid data at power ON.

T3 : The time from valid data off to Vdd off at power Off.

T4 : Vdd off time for Windows restart

T5 : The time from valid data to B/L enable at power ON.

T6 : The time from valid data off to B/L disable at power Off.

NOTE.

- (1) The supply voltage of the external system for the module input should be the same as the definition of V_{DD}.
- (2) Apply the lamp voltage within the LCD operation range. When the back-light turns on before the LCD operation or the LCD turns off before the back-light turns off, the display may momentarily become white.
- (3) In case of V_{DD} = off level, please keep the level of input signals on the low or keep a high impedance.
- (4) T₄ should be measured after the module has been fully discharged between power off and on period.
- (5) Interface signal shall not be kept at high impedance when the power is on.

SEC Secret

Doc.No.	LTN154AT08-001	Rev.No	04-A00-G-071003	Page	21 / 31
---------	----------------	--------	-----------------	------	---------

7. Mechanical Outline dimension

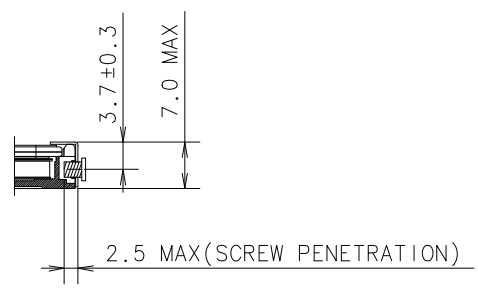
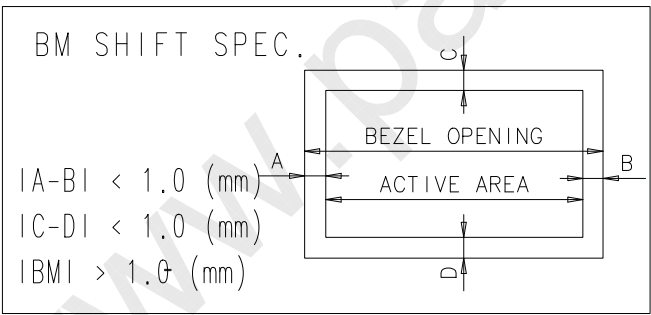
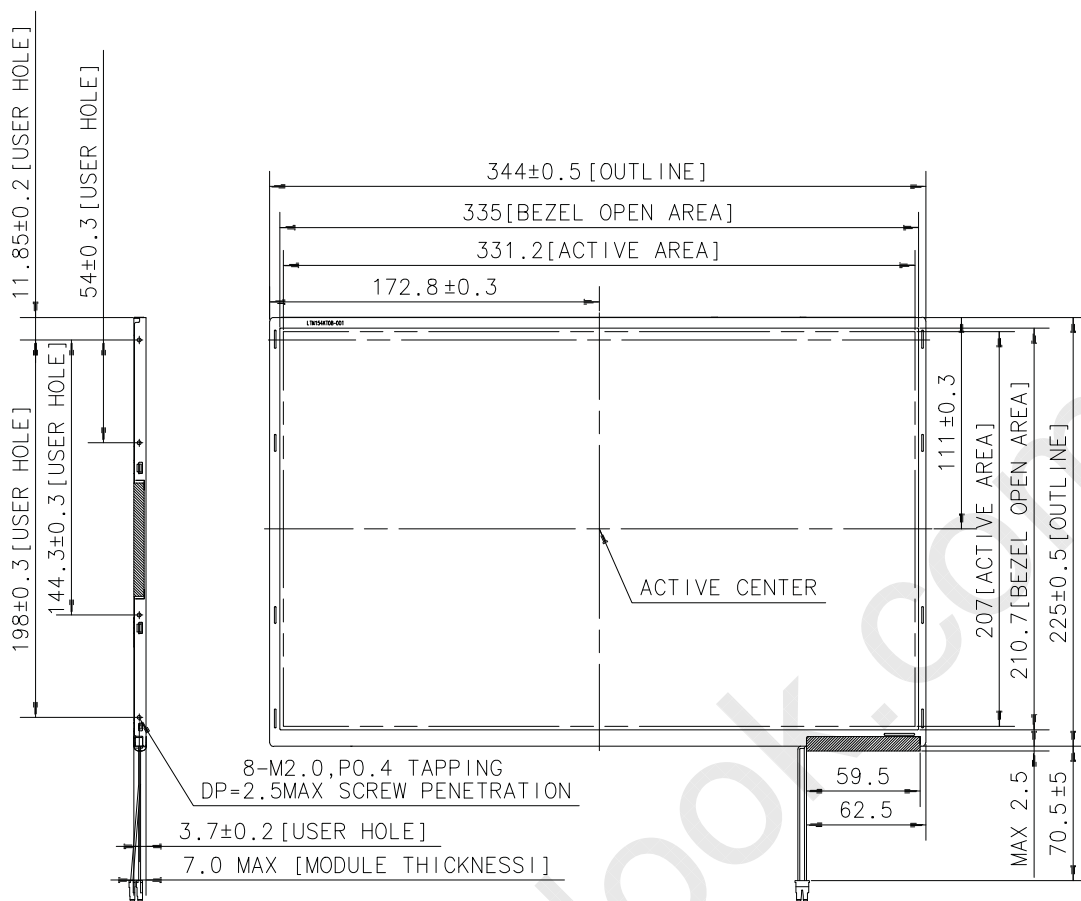

SECTION A-A'

IN THIS AREA, THE THICKNESS IS
OVER 7.0mm WITH NO PRESSURE FORCE

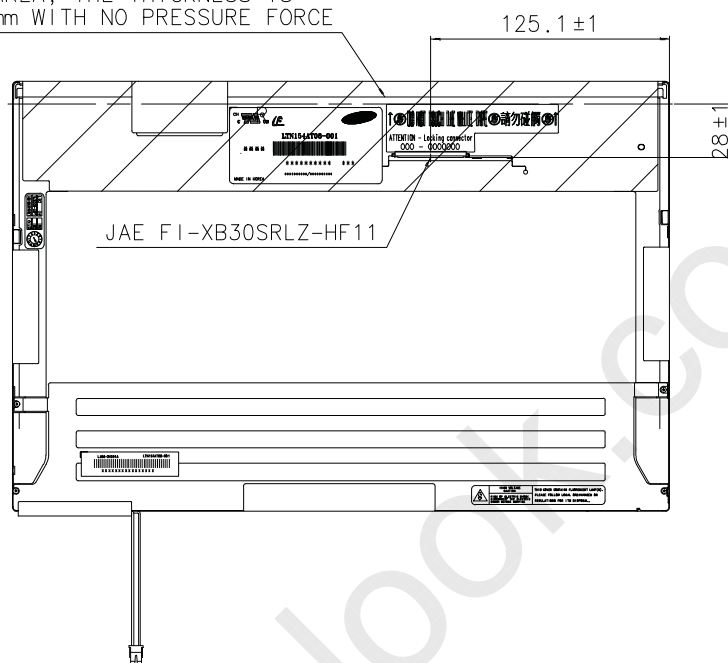

* NOTE

1. SIGNAL INTERFACE CONNECTOR TO BE SPECIFIED AS BELOW.
 - MAKER : JAE OR COMPATIBLE
 - INPUT CONNECTOR : JAE FI-XB30SRLZ-HF11
2. CCFT CONNECTOR FOR BACKLIGHT TO BE SPECIFIED AS BELOW.
 - MAKER : JST
 - PART NO : BHSR-02VS-1
3. TORQUE SPEC : MAX 2.5 Kgf-cm
4. WEIGHT SPEC : TYP 600g, MAX 620g
5. Unless Specified, General Tolerance : ± 0.5

8. PACKING

Approval

1. CARTON(Internal Package)

(1) Packing Form

Corrugated Cardboard box and Corrupad form as shock absorber

(2) Packing Method

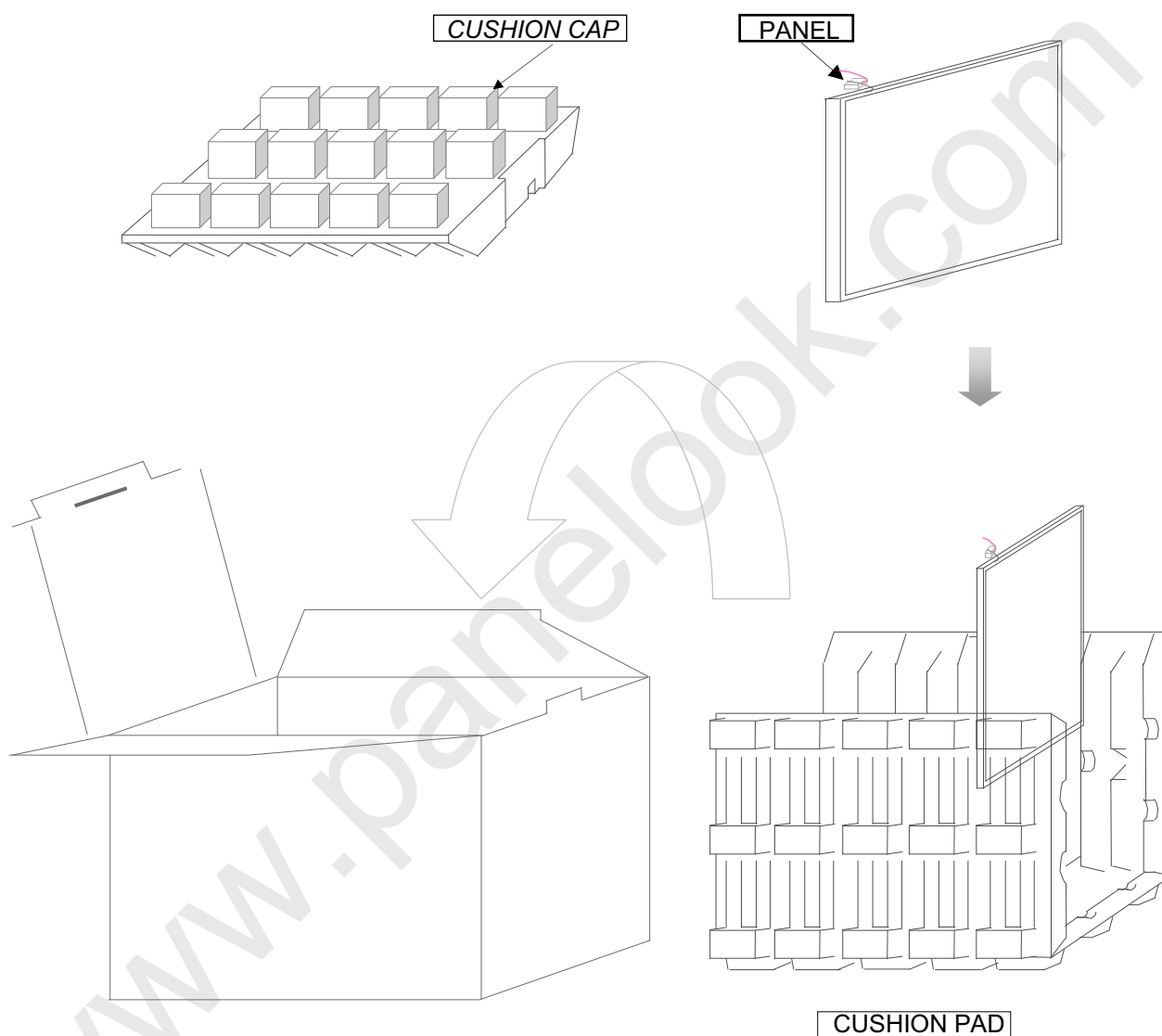

Note 1) Total Weight : Approximately 10 kg

2) Acceptance number of piling : 10 sets

3) Carton size : 408(W) X 325(D) X 295(H)

SEC Secret

Doc.No.	LTN154AT08-001	Rev.No	04-A00-G-071003	Page	24 / 31
---------	----------------	--------	-----------------	------	---------

Approval

(3)Packing Material

No	Part name	Quantity
1	Static electric protective sack	10 pcs
2	Packing case (Inner box) included shock absorber	1 set
3	Pictorial marking	2 pcs
4	Carton	1 set

9. MARKINGS & OTHERS

A nameplate bearing followed by is affixed to a shipped product at the specified location on each product.

(1)Parts number : LTN154AT08

(2)Revision code : 3 letters

(3)Lot number : 5 X 6 A XX XX XX 001

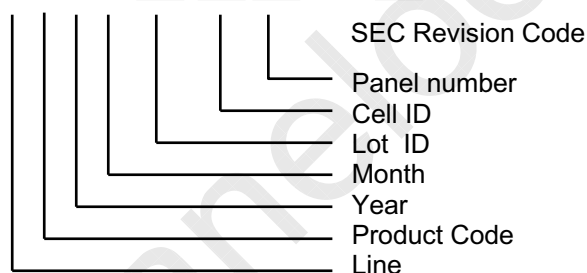

(4) Nameplate Indication

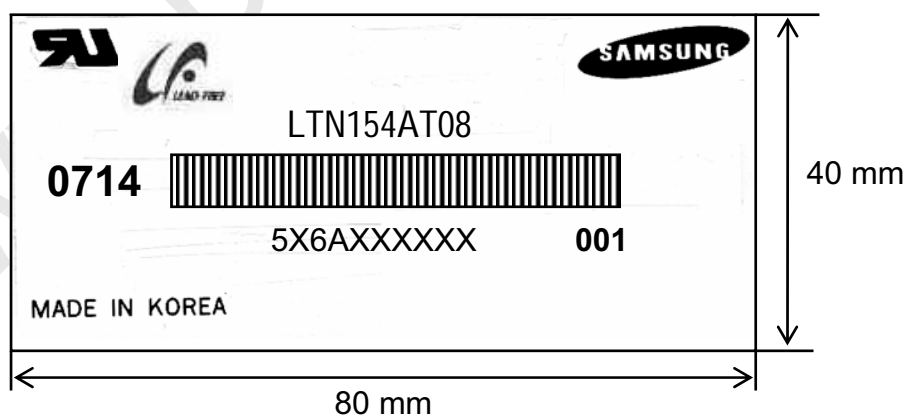

Parts name : LTN154AT08
Lot number : 5X6AXXXXXX
Inspected work week : 0714(2007 year 14th week)
Product Revision Code : 001

SEC Secret

Doc.No.	LTN154AT08-001	Rev.No	04-A00-G-071003	Page	25 / 31
---------	----------------	--------	-----------------	------	---------

Approval

High voltage caution label



(5) Packing small box attach

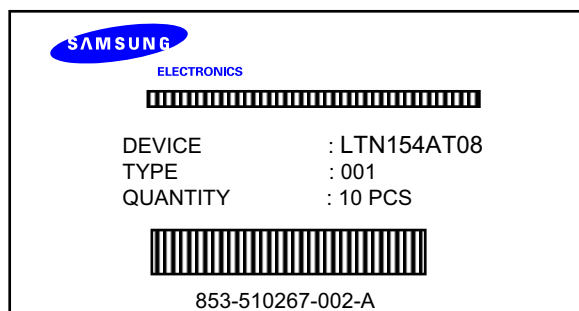

(6) Packing box Marking : Samsung TFT-LCD Brand Name



SEC Secret

Doc.No.	LTN154AT08-001	Rev.No	04-A00-G-071003	Page	26 / 31
---------	----------------	--------	-----------------	------	---------

Approval

10. GENERAL PRECAUTIONS

1. Handling

- (a) When the module is assembled, It should be attached to the system firmly using every mounting holes. Be careful not to twist and bend the modules.
- (b) Refrain from strong mechanical shock and / or any force to the module. In addition to damage, this may cause improper operation or damage to the module and CCFT backlight.
- (c) Note that polarizers are very fragile and could be easily damaged. Do not press or scratch the surface harder than a HB pencil lead.
- (d) Wipe off water droplets or oil immediately. If you leave the droplets for a long time, Staining and discoloration may occur.
- (e) If the surface of the polarizer is dirty, clean it using some absorbent cotton or soft cloth.
- (f) The desirable cleaners are water, IPA(Isoprophyl Alcohol) or Hexane. Do not use Ketone type materials(ex. Acetone), Ethyl alcohol, Toluene, Ethyl acid or Methyl chloride. It might permanent damage to the polarizer due to chemical reaction.
- (g) If the liquid crystal material leaks from the panel, it should be kept away from the eyes or mouth. In case of contact with hands, legs or clothes, it must be washed away thoroughly with soap.
- (h) Protect the module from static, it may cause damage to the C-MOS Gate Array IC.
- (i) Use fingerstalls with soft gloves in order to keep display clean during the incoming inspection and assembly process.
- (j) Do not disassemble the module.
- (k) Do not pull or fold the lamp wire.
- (l) Do not adjust the variable resistor which is located on the back side.
- (m) Protection film for polarizer on the module shall be slowly peeled off just before use so that the electrostatic charge can be minimized.
- (n) Pins of I/F connector shall not be touched directly with bare hands.

SEC Secret

Doc.No.	LTN154AT08-001	Rev.No	04-A00-G-071003	Page	27 / 31
---------	----------------	--------	-----------------	------	---------

Approval

2. STORAGE

- (a) Do not leave the module in high temperature, and high humidity for a long time.
It is highly recommended to store the module with temperature from 0 to 35 °C and relative humidity of less than 70%.
- (b) Do not store the TFT-LCD module in direct sunlight.
- (c) The module shall be stored in a dark place. It is prohibited to apply sunlight or fluorescent light during the store.

3. OPERATION

- (a) Do not connect, disconnect the module in the "Power On" condition.
- (b) Power supply should always be turned on/off by following item 6.3 "Power on/off sequence".
- (c) Module has high frequency circuits. Sufficient suppression to the electromagnetic interference shall be done by system manufacturers. Grounding and shielding methods may be important to minimize the interference.
- (d) The cable between the backlight connector and its inverter power supply shall be a minimized length and be connected directly. The longer cable between the backlight and the inverter may cause lower luminance of lamp(CCFT) and may require higher startup voltage(Vs).
- (e) The standard limited warranty is only applicable when the module is used for general notebook applications. If used for purposes other than as specified, SEC is not to be held reliable for the defective operations. It is strongly recommended to contact SEC to find out fitness for a particular purpose.

4. OTHERS

- (a) Ultra-violet ray filter is necessary for outdoor operation.
- (b) Avoid condensation of water. It may result in improper operation or disconnection of electrode.
- (c) Do not exceed the absolute maximum rating value. (the supply voltage variation, input voltage variation, variation in part contents and environmental temperature, so on)
Otherwise the module may be damaged.
- (d) If the module displays the same pattern continuously for a long period of time, it can be the situation when the image "sticks" to the screen.
- (e) This module has its circuitry PCB's on the rear side and should be handled carefully in order not to be stressed.

SEC Secret

Doc.No.	LTN154AT08-001	Rev.No	04-A00-G-071003	Page	28 / 31
----------------	----------------	---------------	-----------------	-------------	---------

11. EEDID

Approval

LTN154AT08-001(1280 *800) EDID Sheet for NEC						
Address (HEX)	FUNCTION	Value HEX	BIN	DEC	ASCII or Data	Notes
00	Header	00	00000000	0		EDID Header
01		FF	11111111	255		
02		FF	11111111	255		
03		FF	11111111	255		
04		FF	11111111	255		
05		FF	11111111	255		
06		FF	11111111	255		
07		00	00000000	0		
08	ID Manufacturer Name	4C	01001100	76	S	3 character ID
09		A3	10100011	163	E C	"SEC"
0A	ID Product Code	41	01000001	65	[A]	
0B		38	00111000	56	[8]	
0C	32-bit serial no.	00	00000000	0		
0D		00	00000000	0		
0E		00	00000000	0		
0F		00	00000000	0		
10	Week of manufacture	00	00000000	0		
11	Year of manufacture	11	00010001	17	2007	2007
12	EDID Structure Ver.	01	00000001	1	1	EDID Ver. 1.0
13	EDID revision #	03	00000011	3	3	EDID Rev. 3
14	Video input definition	80	10000000	128		
15	Max H image size	21	00100001	33	33	33 cm(approx)
16	Max V image size	15	00010101	21	21	21 cm(approx)
17	Display Gamma	78	01111000	120	2.2	Gamma 2.2
18	Feature support	0A	00001010	10		
19	Red/green low bits	FC	11111100	252		11111100
1A	Blue/white low bits	F5	11110101	245		11110101
1B	Red x/ high bits	A4	10100100	164	0.644	Red x 0.644= 1010010011
1C	Red y	55	01010101	85	0.335	Red y 0.335= 0101010111
1D	Green x	49	01001001	73	0.288	Green x 0.288= 0100100111
1E	Green y	99	10011001	153	0.598	Green y 0.598= 1001100100
1F	Blue x	24	00100100	36	0.144	Blue x 0.144= 0010010011
20	Blue y	12	00010010	18	0.073	Blue y 0.073= 0001001011
21	White x	50	01010000	80	0.313	White x 0.313= 0101000001
22	White y	54	01010100	84	0.329	White y 0.329= 0101010001
23	Established timing 1	00	00000000	0		
24	Established timing 2	00	00000000	0		
25	Established timing 3	00	00000000	0		
26	Standard timing #1	01	00000001	1		not used
27		01	00000001	1		
28	Standard timing #2	01	00000001	1		not used
29		01	00000001	1		
2A	Standard timing #3	01	00000001	1		not used
2B		01	00000001	1		

SEC Secret

Doc.No.

LTN154AT08-001

Rev.No

04-A00-G-071003

Page

29 / 31

Approval

2C	Standard timing #4	01	00000001	1		not used
2D		01	00000001	1		
2E	Standard timing #5	01	00000001	1		not used
2F		01	00000001	1		
30	Standard timing #6	01	00000001	1		not used
31		01	00000001	1		
32	Standard timing #7	01	00000001	1		not used
33		01	00000001	1		
34	Standard timing #8	01	00000001	1		not used
35		01	00000001	1		
36	Detailed timing/monitor descriptor #1	EE	11101110	238	68.94	Main clock= 68.94 MHz
37		1A	00011010	26		
38		00	00000000	0	1280	Hor active=640*2 pixels
39		80	10000000	128	128	Hor blanking=128 pixels
3A		50	01010000	80		4bit : 4bit
3B		20	00100000	32	800	Vertical active=800 lines
3C		10	00010000	16	16	Vertical blanking=16 lines
3D		30	00110000	48		4bit : 4bit
3E		10	00010000	16	16	Hor sync. Offset=16 pixels
3F		30	00110000	48	48	H sync. Width=48 pixels
40		13	00010011	19	1 3	Vsync. Offset=1 lines Vsync. Width=3 lines
41		00	00000000	0		2bit : 2bit :2bit :2bit
42		4B	01001011	75	331	H image size= 331 mm(approx)
43		CF	11001111	207	207	Vimage size = 207 mm(approx)
44	10	00010000	16			
45	00	00000000	0		No Horizontal Border	
46	00	00000000	0		No Vertical Border	
47	19	00011001	25			
48	Detailed timing/monitor descriptor #2	00	00000000	0		Manufacturer Specified (Timing)
49		00	00000000	0		
4A		00	00000000	0		
4B		0F	00001111	15		
4C		00	00000000	0		
4D		00	00000000	0		Value=HSPW/min / 2
4E		00	00000000	0		Value=HSPW/max / 2
4F		00	00000000	0		Value=Thbpmmin / 2
50		00	00000000	0		Value=Thbpmmax / 2
51		00	00000000	0		Value=VSPW/min / 2
52		00	00000000	0		Value=VSPW/max / 2
53		00	00000000	0		Value=TVbpmmin / 2
54		00	00000000	0		Value=TVbpmmax / 2
55		23	00100011	86		Thpmin=value*2 + HA pixelclks
56	87	10000111	186		Thpmax=value*2 + HA pixelclks	
57	02	00000010	2		Tvpmin=value*2 + VA lines	
58	64	01100100	100		Tvpmax=value*2 + VA lines	
59	00	00000000	0		Module revision	

SEC Secret

Doc.No.

LTN154AT08-001

Rev.No

04-A00-G-071003

Page

30 / 31

Approval

5A	Detailed timing/monitor descriptor #3	00	00000000	0		ASCII Data String Tag
5B		00	00000000	0		
5C		00	00000000	0		
5D		FE	11111110	254		
5E		00	00000000	0		
5F		53	01010011	83	[S]	
60		41	01000001	65	[A]	
61		4D	01001101	77	[M]	
62		53	01010011	83	[S]	
63		55	01010101	85	[U]	
64		4E	01001110	78	[N]	
65		47	01000111	71	[G]	
66		0A	00001010	10	[*]	
67		20	00100000	32	[]	
68		20	00100000	32	[]	
69	20	00100000	32	[]		
6A	20	00100000	32	[]		
6B	20	00100000	32	[]		
6C	Detailed timing/monitor descriptor #4	00	00000000	0		Monitor Name Tag (ASCII)
6D		00	00000000	0		
6E		00	00000000	0		
6F		FE	11111110	254		
70		00	00000000	0		
71		4C	01001100	76	[L]	
72		54	01010100	84	[T]	
73		4E	01001110	78	[N]	
74		31	00110001	49	[1]	
75		35	00110101	53	[5]	
76		34	00110100	52	[4]	
77		41	01000001	65	[A]	
78		54	01010100	84	[T]	
79		30	00110000	48	[0]	
7A		38	00111000	56	[8]	
7B	30	00110000	48	[0]		
7C	30	00110000	48	[0]		
7D	31	00110001	49	[1]		
7E	Extension Flag	00	00000000	0		
7F	Checksum	D4	11010100	212		

SEC Secret

Doc.No.	LTN154AT08-001	Rev.No	04-A00-G-071003	Page	31 / 31
---------	----------------	--------	-----------------	------	---------