

SAMSUNG

ELECTRONICS

Approval



TO :
DATE : July 6. 2010

SAMSUNG TFT-LCD

MODEL NO : LTN156AT14-F01

NOTE : Extension code [F]
→ LTN156AT14-F
Surface type [**Glare**]

The information described in this SPEC is preliminary and can be changed without prior notice.

APPROVED BY : **S.K Lee**

PREPARED BY : LCD Application Engineering Part2 , TCS Team

SAMSUNG ELECTRONICS CO., LTD.



Samsung Secret

Doc.No.	LTN156AT14-F01	Rev.No	04-A00-S-100706	Page	1 / 32
---------	----------------	--------	-----------------	------	--------

CONTENTS

Revision History	----- (3)
General Description	----- (4)
1. Absolute Maximum Ratings	----- (5)
1.1 Absolute Ratings of environment	
1.2 Electrical Absolute Ratings	
2. Optical Characteristics	----- (7)
3. Electrical Characteristics	----- (10)
3.1 TFT LCD Module	
3.2 Backlight Unit	
3.3 LED Driver	
4. Block Diagram	----- (13)
4.1 TFT LCD Module	
5. Input Terminal Pin Assignment	----- (14)
5.1 Input Signal & Power	
5.2 LVDS Interface	
5.3 Timing Diagrams of LVDS For Transmitting	
5.4 Input Signals, Basic Display Colors and Gray Scale of Each Color.	
5.5 Pixel format	
6. Interface Timing	----- (19)
6.1 Timing Parameters	
6.2 Timing Diagrams of interface Signal	
6.3 Power ON/OFF Sequence	
7. Outline Dimension	----- (21)
8. Packing	----- (24)
9. Markings & Others	----- (26)
10. General Precautions	----- (28)
11. EDID	----- (30)

Samsung Secret

REVISION HISTORY

Approval

Date	Revision No.	Page	Summary
Apr. 23. 2010	P00	All	.The preliminary specification of LTN156AT14-F01 was issued first.
Apr. 26. 2010	P01	p.30 – p.32	.The EDID was updated.
May 20. 2010	P02	p. 6 p. 10 p. 12	.The Max. voltage of logic input was changed from +2.45V to +0.3. .The Min. & Max. value of Main frequency were updated. .The Min. of PWM frequency was updated as 0.1KHz.
July, 6. 2010	A00	All p. 6 p. 7 p. 9 p. 10 p. 12 p. 14 p. 15 p.22~23 p.26~27 p.30~32	.The approval specification of LTN156AT14-F01 was updated. .The absolute rating of VLED was updated as Fujitsu's request. .Typ. and Min. value of viewing angle was updated. .fDCLX was changed from 72.33MHz to 75.55MHz. .SEC changed definition of 13points positions as HD resolution. .SEC updated Power based on real value. .fDCLX was changed from 72.33MHz to 75.55MHz. .LED driver was changed from Richtek(RT8561) to Intersil (ISL97670) as Fujitsu's request. .Due to changing LED driver, Max. of PWM low level, Min. of PWM high level and Max. of LED enable were changed. .The name of LVDS connector was changed from IPEX 20455-040E-12 to IPEX 20455-040E-02R. .LED enable off range was changed from 0~0.1V to 0~0.8V. .The name of LVDS connector was changed from IPEX 20455-040E-02S to IPEX 20455-040E-02R. .Outline dimension was updated. .Fujitsu's CP No was updated. [CP496542-01 01A] .EDID was changed as correcting Gx. (0.335 to 0.330) [Checksum 68] → [Checksum 6D]

Samsung Secret

GENERAL DESCRIPTION

DESCRIPTION

LTN156AT14 is a color active matrix TFT (Thin Film Transistor) liquid crystal display (LCD) that uses amorphous silicon TFT as switching devices. This model is composed of a TFT LCD panel, a driver circuit and a backlight system. The resolution of a 15.6" contains 1366 x 768 pixels and can display up to 262,144 colors. 6 O'clock direction is the Optimum viewing angle.

FEATURES

- Thin and light weight
- High contrast ratio, high aperture structure
- 1366 x 768 pixels resolution (16:9)
- Fast Response Time
- Low power consumption
- LED BLU Structure
- DE (Data enable) only mode
- 3.3V LVDS Interface
- On board EDID chip
- Pb-free product
- RoHS comply product

APPLICATIONS

- Notebook PC
- If the usage of this product is not for PC application, but for others, please contact SEC

GENERAL INFORMATION

Item	Specification	Unit	Note
Display area	344.232 (H) x 193.536 (V) (15.6"diagonal)	mm	
Driver element	a-Si TFT active matrix		
Display colors	262,144		
Number of pixel	1366 x 768	pixel	16 : 9
Pixel arrangement	RGB vertical stripe		
Pixel pitch	0.252 (H) x 0.252 (V) (TYP.)	mm	
Display Mode	Normally white		
Surface treatment	Haze 0, Hardness 3H (Reflection ratio 4~5%)		Glare

Samsung Secret

Mechanical Information

Approval

Item		Min.	Typ.	Max.	Unit	Note
Module Size	Horizontal (H)	358.8	359.3	359.8	mm	
	Vertical (V)	209.0	209.5	210.0	mm	
	Depth (D)	-	-	5.65	mm	(1)
Weight		-	458	490	g	

Note (1) Measurement condition of outline dimension
 . Equipment : Vernier Calipers
 . Push Force : 750g · f (minimum)

1. ABSOLUTE MAXIMUM RATINGS

1.1 ENVIRONMENTAL ABSOLUTE RATINGS

Item	Symbol	Min.	Max.	Unit	Note
Storage temperate	T_{STG}	-20	60	°C	(1)
Operating temperate (Temperature of glass surface)	T_{OPR}	0	50	°C	(1)
Shock (non-operating)	Snop	-	210	G	(2),(5)
			50		(3),(5)
Vibration (non-operating)	Vnop	-	2.41	G	(4),(5)
Altitude (operation)	-	-	10,000	feet	
Altitude (storage)	-	-	40,000	feet	

Note (1) Temperature and relative humidity range are shown in the figure below.
 95 % RH Max. ($40\text{ }^{\circ}\text{C} > T_a$)
 Maximum wet - bulb temperature at $39\text{ }^{\circ}\text{C}$ or less. ($T_a \geq 40\text{ }^{\circ}\text{C}$) No condensation.
 (2) 2ms, half sine wave, one time for $\pm X, \pm Y, \pm Z$.
 (3) 11ms, Trapezoidal wave, one time for $\pm X, \pm Y, \pm Z$.
 (4) 5~500 Hz, Random vibration, 30 min for X,Y,Z.
 (5) At testing Vibration and Shock, the fixture in holding the Module to be tested have to be hard and rigid enough so that the Module would not be twisted or bent by the fixture.

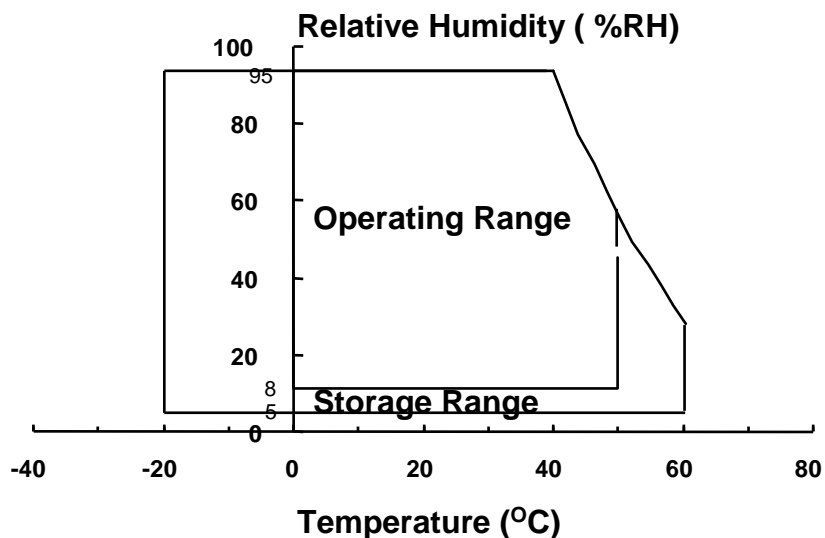

Samsung Secret

1.2 ELECTRICAL ABSOLUTE RATINGS

(1) TFT LCD MODULE

 $V_{DD} = 3.3V, V_{SS} = GND = 0V$

Item	Symbol	Min.	Max.	Unit	Note
Power Supply Voltage	V_{DD}	$V_{DD} - 0.3$	$V_{DD} + 0.3$	V	(1)
Logic Input Voltage	V_{DD}	$V_{DD} - 0.3$	$V_{DD} + 0.3$	V	(1)
Absolute rating of VLED	V_{LED}	4.5	26	V	(1)

Note (1) Within T_a (25 ± 2 °C)

Samsung Secret

2. OPTICAL CHARACTERISTICS

The following items are measured under stable conditions. The optical characteristics should be measured in a dark room or equivalent state with the methods shown in Note (5).
Measuring equipment : TOPCON SR-3

* $T_a = 25 \pm 2 \text{ }^\circ\text{C}$, $V_{DD}=3.3\text{V}$, $f_v=60\text{Hz}$, $f_{DCLK} = 75.55 \text{ MHz}$, PWM duty = 100%

Item		Symbol	Condition	Min.	Typ.	Max	Unit	Note
Contrast Ratio		CR	1center point	400	500	-	-	(1), (2), (5)
Response Time at T_a (Rising + Falling)		$T_R + T_F$		-	16 (6+10)	25	msec	(1), (3)
Average Luminance of White		$Y_{L,AVE}$	1center point	340	400	-	cd/m ²	PWM duty = 100% (4)
Color Chromaticity (CIE 1931)	Red	R_X	Normal Viewing Angle $\phi = 0$ $\theta = 0$	0.585	0.615	0.645	-	(1), (5) SR-3
		R_Y		0.325	0.355	0.385		
	Green	G_X		0.300	0.330	0.360		
		G_Y		0.580	0.610	0.640		
	Blue	B_X		0.120	0.150	0.180		
		B_Y		0.070	0.100	0.130		
	White	W_X		0.283	0.313	0.343		
		W_Y		0.299	0.329	0.359		
Viewing Angle	Hor.	θ_L	$CR \geq 10$	40	45	-	Degrees	(1), (5)
		θ_R		40	45	-		
	Ver.	ϕ_H		10	15	-		
		ϕ_L		30	35	-		
Color Gamut				-	60	-	%	
13 Points White Variation		δ_L		-	-	1.7	-	(6)

Samsung Secret

Note 1) Definition of Viewing Angle : Viewing angle range($10 \leq C/R$)

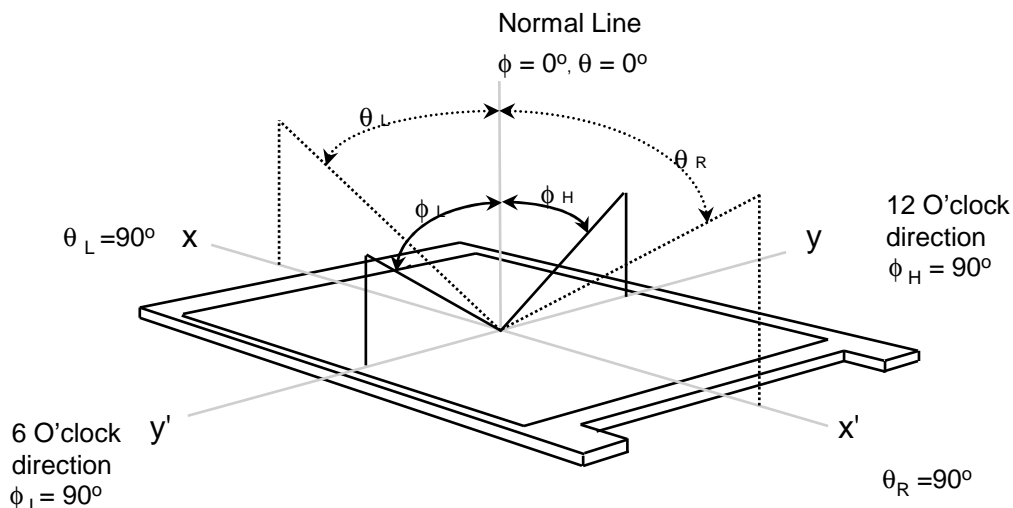

Note 2) Definition of Contrast Ratio (CR) : Ratio of gray max (Gmax) ,gray min (Gmin) at center 1point

$$CR = CR(7)$$

Points : (7) at the figure of Note (6).

Note 3) Definition of Response time :

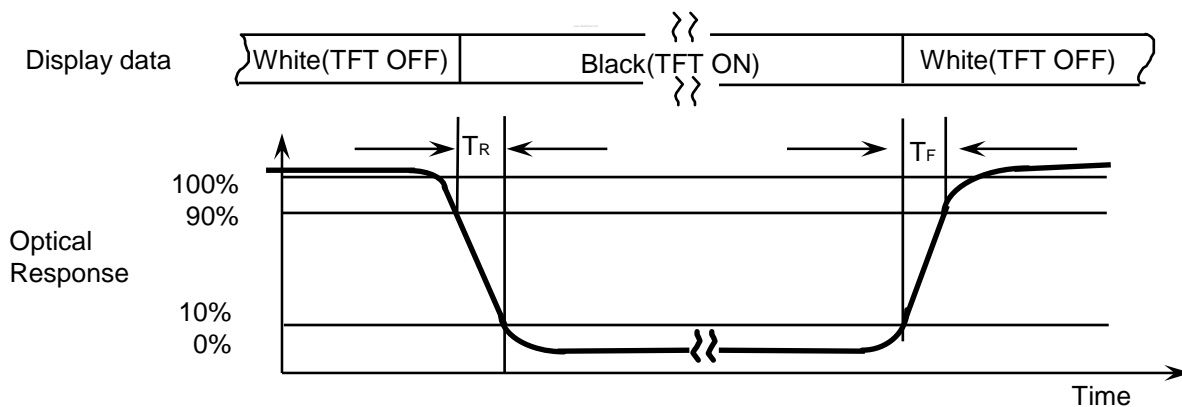

Note 4) Definition of Average Luminance of White : measure the luminance of white at center 1 point.

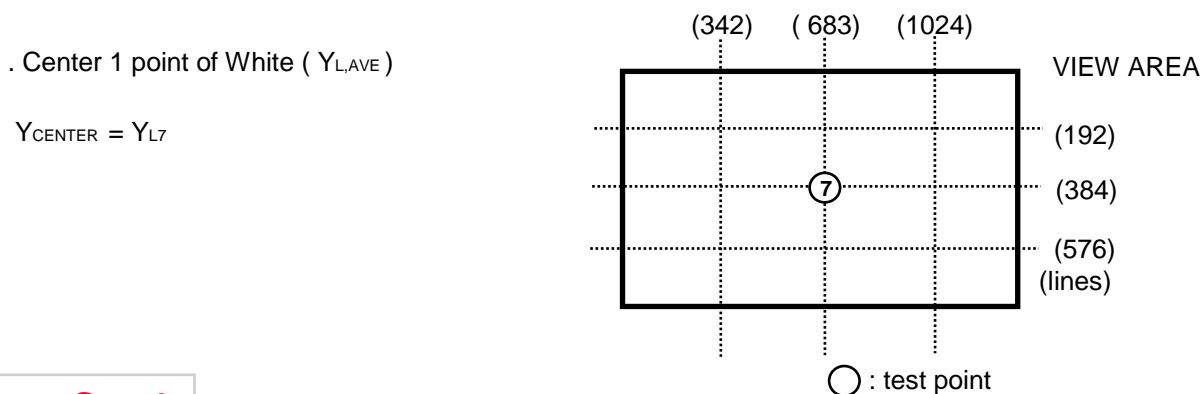

Samsung Secret

Note 5) After stabilizing and leaVBLg the panel alone at a given temperature for 30 min , the measurement should be executed. Measurement should be executed in a stable, windless, and dark room. 30 min after lighting the backlight. This should be measured in the center of screen.
 LED current : 24.0 mA
 Environment condition : Ta = 25 ± 2 °C

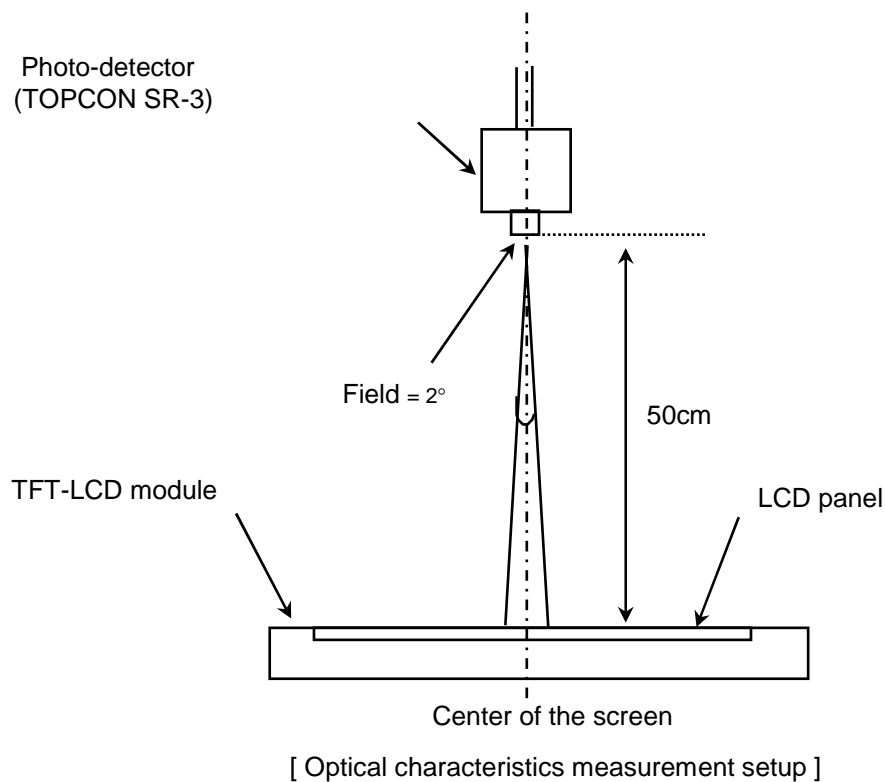

Note 6) Definition of 13 points white variation (δL), [① ~ ⑬]

$$\delta L = \frac{\text{Maximum luminance of 13 points}}{\text{Minimum luminance of 13 points}}$$

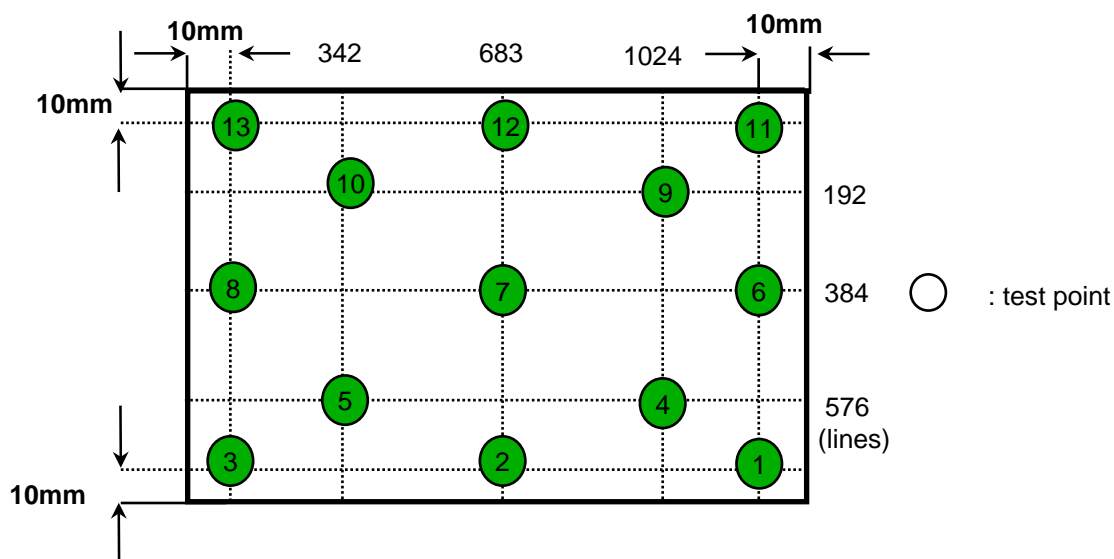

Samsung Secret

3. ELECTRICAL CHARACTERISTICS

Approval

3.1 TFT LCD MODULE

Ta= 25 ± 2°C

Item	Symbol	Min.	Typ.	Max.	Unit	Note	
Voltage of Power Supply	V _{DD}	3.0	3.3	3.6	V		
Differential Input Voltage for LVDS Receiver Threshold	High	V _{IH}	-	-	+100	mV	V _{CM} = +1.2V (+/- 10%)
	Low	V _{IL}	-100	-	-	mV	
Vsync Frequency	f _V	-	60	-	Hz		
Main Frequency	f _{DCLK}	67.5	75.55	80	MHz		
EDID Input Voltage	V _{EDID}	1.8	3.3	5.5	V		
EDID Input Current	I _{EDID}	-	0.8	1.0	mA	V _{EDID} =1.8V, f _c =400kHz	
Skew	R _{SKM}	-400	-	+400	ps	f _{DCLK} =75.55Mhz	
Rush Current	I _{RUSH}	-	-	1.5	A	(5)	
Current of Power Supply	White	I _{DD}	-	250	-	mA	(2),(4)*a
	Mosaic		-	350	-	mA	(2),(4)*b
	V. Stripe		-	380	-	mA	(2),(4)*c
	Black		-	400	450	mA	(2),(3),(4)*d

- Note (1) Display data pins and timing signal pins should be connected.(GND = 0V)
 (2) f_V = 60Hz, f_{DCLK} = 75.55 MHz, V_{DD} = 3.3V , DC Current.
 (3) Max. 700mA is fixed by the average of Max. current in the SEC's test. (So, almost panels are under 700mA, but please also allow some Max. currents that are over 700mA by peaks.)
 (4) Power dissipation pattern

*a) White Pattern

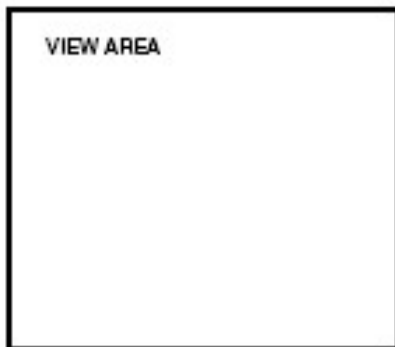

*b) Mosaic Pattern

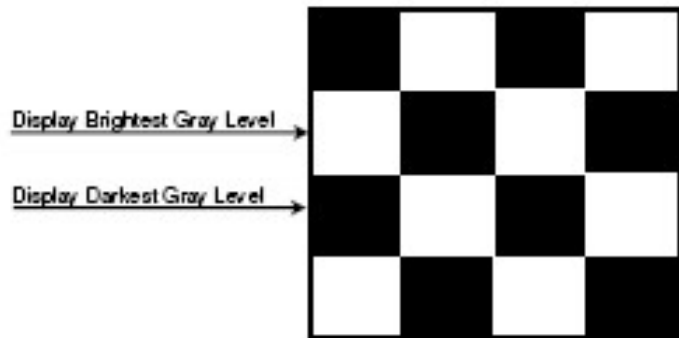

Samsung Secret

*c) 1dot Vertical stripe pattern

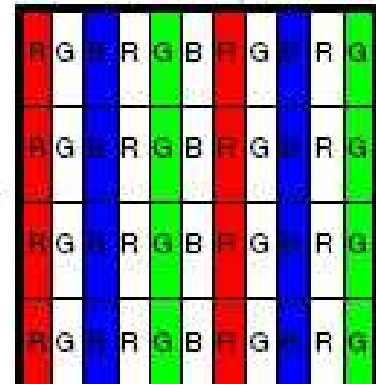
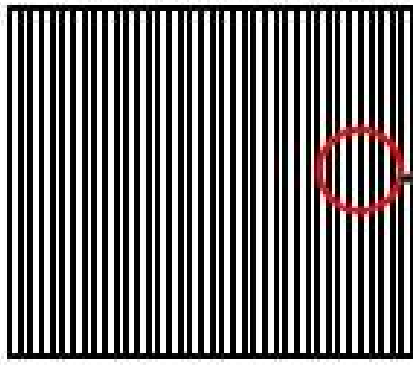

*d) Black Pattern

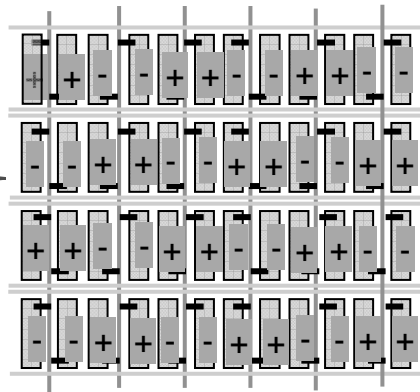

5) Rush current measurement condition

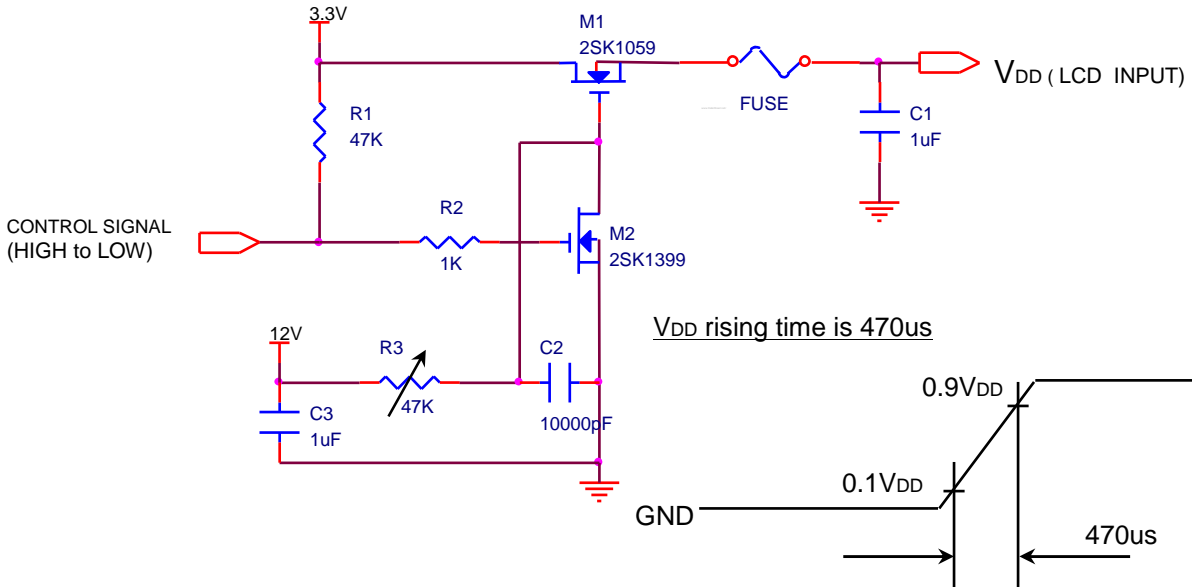

Samsung Secret

3.2 BACK-LIGHT UNIT

Ta= 25 ± 2 °C

Item	Symbol	Min.	Typ.	Max.	Unit	Note
Operating Life Time	Hr	12,000	-	-	Hr	(1)

Note (1) Life time (Hr) of LEDs can be defined as the time in which it continues to operate under the condition Ta= 25 ± 2 °C and PWM duty = 100% until one of the following event occurs.

- When the brightness becomes 50% or lower than the original.

3.3 LED Driver

- LED Driver Manufacturer : Intersil (ISL97670)

Ta= 25 ± 2 °C

Item	Symbol	Min.	Typ.	Max.	Unit	Note
Input Voltage	V _{BL}	7	12	21	V	
V _{LED} on level voltage	V _{LED_on}	7	-	21	V	
V _{LED} off level voltage	V _{LED_off}	0	-	4	V	
Input Current	I	-	-	550	mA	Duty=100%, V _{BLU} =12V
Input Power	Pin	-	-	6.5	W	Pin = V _{BL} x I, V _{BLU} = 12V
PWM duty ratio	-	6	-	100	%	(1)
PWM Frequency	F _{PWM}	0.1	1	10	KHz	(1)
PWM Impedance	Z _{PWM}	2.4	-	-	Mohm	
PWM high level vol.	V _{PWM_H}	1.5	3.3	5.0	V	
PWM low level vol.	V _{PWM_L}	0	0	0.5	V	
LED_EN Impedance	Z _{PWM}	50	-	-	Mohm	
LED_EN high vol.	V _{LED_EN_H}	1.5	-	5.0	V	
LED_EN low vol.	V _{LED_EN_L}	0	-	0.8	V	
LED rush current	I _{LED RUSH}	-	-	1.5	A	

Note - (1) PWM can be guaranteed under the same condition as operation temperature T_{OPR} 0 ~ 50 °C.

Samsung Secret

4. BLOCK DIAGRAM

4.1 TFT LCD Module

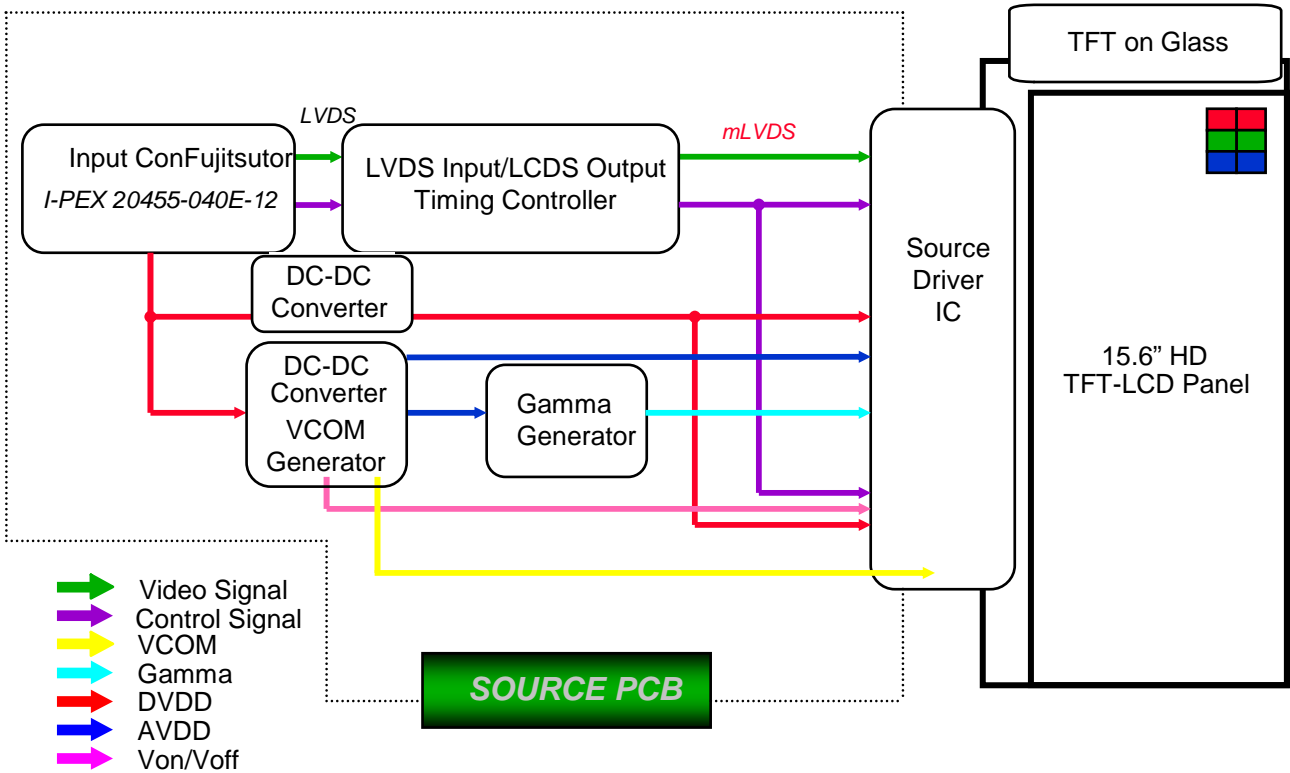

4.2 LED conFujitsution and placement

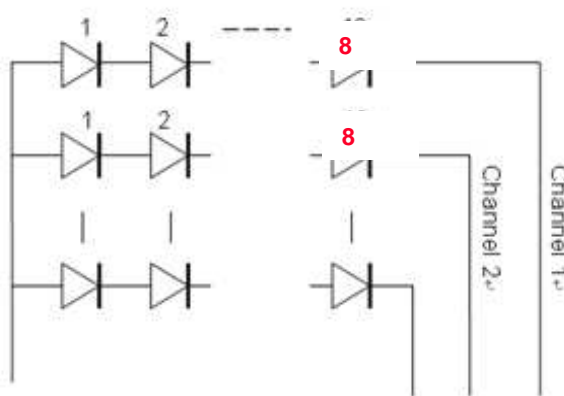

8 LEDs x 8 channels = Total 64 LEDs

LED Wiring

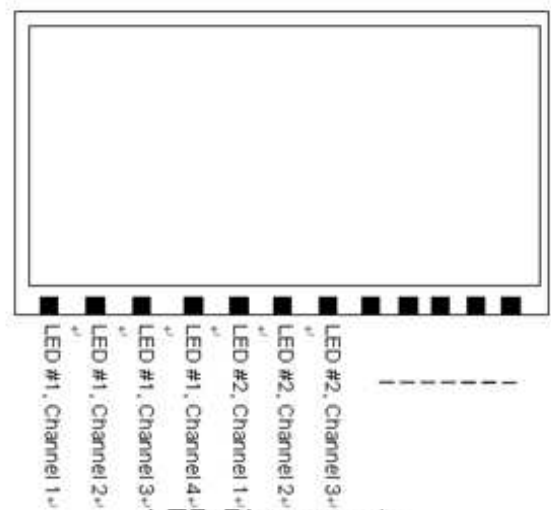

LED Placement

Samsung Secret

5. INPUT TERMINAL PIN ASSIGNMENT

Approval

5.1. Input Signal & Power LVDS, ConFujitsutor : IPEX 20455-040E-02R
Mating ConFujitsutor: IPEX 20454-040T-01

Pin	Symbol	Function
1	NC	No ConFujitsution (Reserved for supplier)
2	VCC	Power Supply, 3.3V (typical)
3	VCC	Power Supply, 3.3V (typical)
4	VCC_EDID	DDC 3.3V power
5	WPN	EDID writing proction
6	CLK_EDID	DDC clock
7	DATA_EDID	DDC data
8	RXin0-	LVDS 0th Signal Negative (Odd)
9	RXin0+	LVDS 0th Signal Positive (Odd)
10	GND	Ground
11	RXin1-	LVDS 1st Signal Negative (Odd)
12	RXn1+	LVDS 1st Signal Positive (Odd)
13	GND	Ground
14	RXin2-	LVDS 2nd Signal Negative (Odd)
15	RXn2+	LVDS 2nd Signal Positive (Odd)
16	GND	Ground
17	ClKIN-	LVDS Clock Signal Negative (Odd)
18	ClKIN+	LVDS Clock Signal Positive (Odd)
19	GND	Ground
20~21	NC	No ConFujitsution
22	GND	Ground
23~24	NC	No ConFujitsution
25	GND	Ground
26~27	NC	No ConFujitsution
28	GND	Ground
29~30	NC	No ConFujitsution
31~33	GND	Ground
34	NC	No ConFujitsution
35	PWM	PWM for luminance control
36	LED_EN	BL On/Off (On : 1.5 ~ 5.0, Off : 0 ~ 0.8V)
37	NC	No ConFujitsution
38~40	VBL(7~21)	LED power supply 7V ~ 21V

Samsung Secret

5.2 LVDS Interface : Transmitter DS90CF363 or Compatible

Pin No.	Name	RGB Signal	Pin No.	Name	RGB Signal
51	TxIN0	R0	14	TxIN14	G5
52	TxIN1	R1	15	TxIN15	B0
54	TxIN2	R2	19	TxIN18	B1
55	TxIN3	R3	20	TxIN19	B2
56	TxIN4	R4	22	TxIN20	B3
3	TxIN6	R5	23	TxIN21	B4
4	TxIN7	G0	24	TxIN22	B5
6	TxIN8	G1	27	TxIN24	Hsync
7	TxIN9	G2	28	TxIN25	Vsync
11	TxIN12	G3	30	TxIN26	DE
12	TxIN13	G4	31	TxCLKIN	Clock

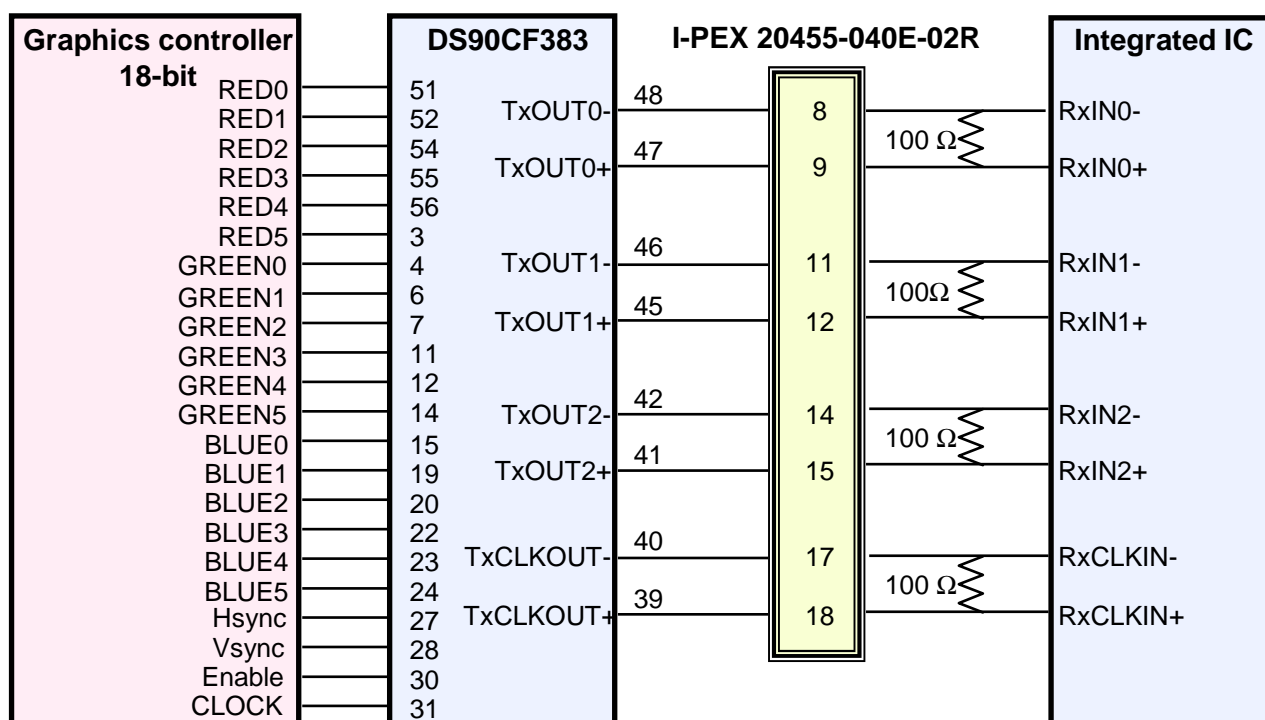
LVDS INTERFACE

Note : The LCD Module uses a 100ohm resistor between positive and negative lines of each receiver input.

Samsung Secret

5.3 LVDS characteristics

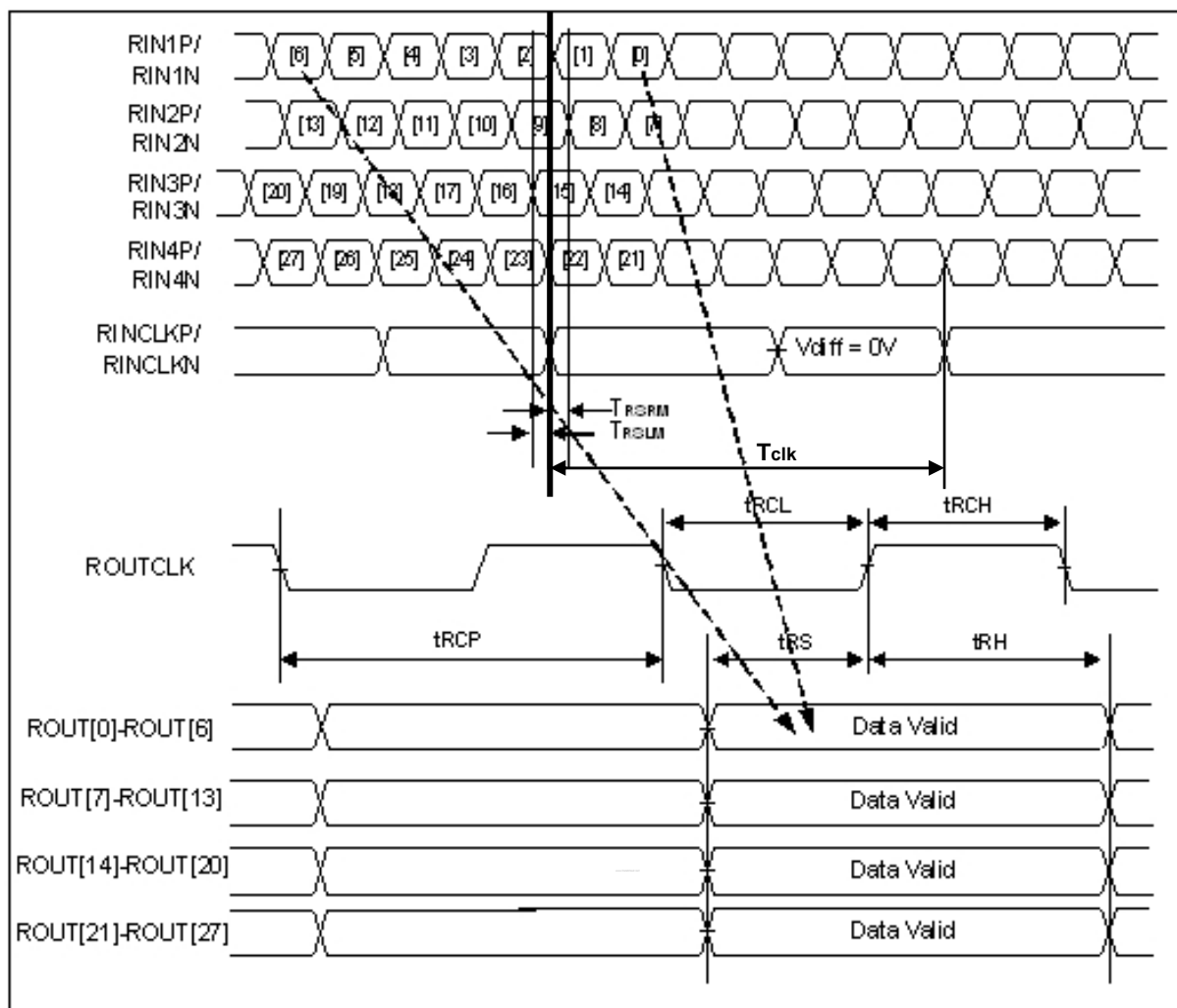

< Definition of LVDS AC characteristics >

Samsung Secret

5.4 Input Signals, Basic Display Colors and Gray Scale of Each Color

Color	Display	Data Signal																Gray Scale Level	
		Red					Green					Blue							
		R0	R1	R2	R3	R4	R5	G0	G1	G2	G3	G4	G5	B0	B1	B2	B3		45
Basic Colors	Black	0	0	0	0	0	0	0	0	0	0	0	0	0	0	0	0	0	-
	Blue	0	0	0	0	0	0	0	0	0	0	0	0	1	1	1	1	1	-
	Green	0	0	0	0	0	0	1	1	1	1	1	1	0	0	0	0	0	-
	Cyan	0	0	0	0	0	0	1	1	1	1	1	1	1	1	1	1	1	-
	Red	1	1	1	1	1	1	0	0	0	0	0	0	0	0	0	0	0	-
	Magenta	1	1	1	1	1	1	0	0	0	0	0	0	1	1	1	1	1	-
	Yellow	1	1	1	1	1	1	1	1	1	1	1	1	0	0	0	0	0	-
	White	1	1	1	1	1	1	1	1	1	1	1	1	1	1	1	1	1	-
Gray Scale Of Red	Black	0	0	0	0	0	0	0	0	0	0	0	0	0	0	0	0	0	R0
	Dark	1	0	0	0	0	0	0	0	0	0	0	0	0	0	0	0	0	R1
	↑	0	1	0	0	0	0	0	0	0	0	0	0	0	0	0	0	0	R3~R60
	:	:	:	:	:	:	:	:	:	:	:	:	:	:	:	:	:	:	
	↓	1	0	1	1	1	1	0	0	0	0	0	0	0	0	0	0	0	R61
	Light	0	1	1	1	1	1	0	0	0	0	0	0	0	0	0	0	0	R62
	Red	1	1	1	1	1	1	0	0	0	0	0	0	0	0	0	0	0	R63
	Gray Scale Of Green	Black	0	0	0	0	0	0	0	0	0	0	0	0	0	0	0	0	0
Dark		0	0	0	0	0	0	1	0	0	0	0	0	0	0	0	0	0	G1
↑		0	0	0	0	0	0	0	1	0	0	0	0	0	0	0	0	0	G3~G60
:		:	:	:	:	:	:	:	:	:	:	:	:	:	:	:	:	:	
↓		0	0	0	0	0	0	1	0	1	1	1	1	0	0	0	0	0	G61
Light		0	0	0	0	0	0	0	1	1	1	1	1	0	0	0	0	0	G62
Green		0	0	0	0	0	0	1	1	1	1	1	1	0	0	0	0	0	G63
Gray Scale Of Blue		Black	0	0	0	0	0	0	0	0	0	0	0	0	0	0	0	0	0
	Dark	0	0	0	0	0	0	0	0	0	0	0	0	1	0	0	0	0	B1
	↑	0	0	0	0	0	0	0	0	0	0	0	0	0	1	0	0	0	B2
	:	:	:	:	:	:	:	:	:	:	:	:	:	:	:	:	:	:	B3~B60
	↓	0	0	0	0	0	0	0	0	0	0	0	0	1	0	1	1	1	
	Light	0	0	0	0	0	0	0	0	0	0	0	0	0	1	1	1	1	B62
	Blue	0	0	0	0	0	0	0	0	0	0	0	0	1	1	1	1	1	B63

Note 1) Definition of gray :

Rn: Red gray, Gn: Green gray, Bn: Blue gray (n=gray level)

Note 2) Input signal: 0 =Low level voltage, 1=High level voltage

Samsung Secret

5.5 Pixel Format in the display

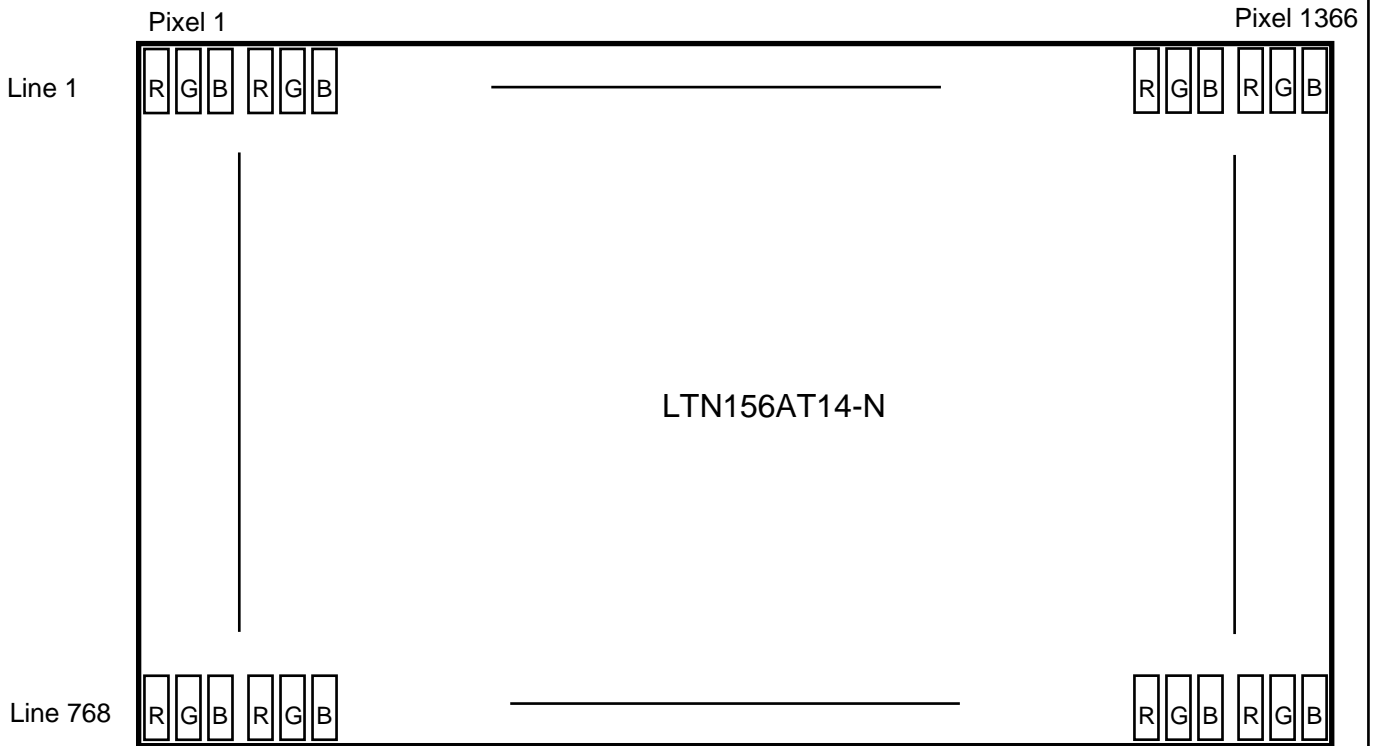

Samsung Secret

6. INTERFACE TIMING

6.1 Timing Parameters

Signal	Item	Symbol	Min.	Typ.	Max.	Unit	Note
Frame Frequency	Cycle	TV	780	790	807	Lines	-
Vertical Active Display Term	Display Period	TVD	-	768	-	Lines	
One Line Scanning Time	Cycle	TH	1430	1526	1620	Clocks	2pixel /clock (1)
Horizontal Active Display Term	Display Period	THD	-	1366	-	Pixels	-

Note 1) DE signal always should have the same cycle during operation.

6.2 Timing diagrams of interface signal

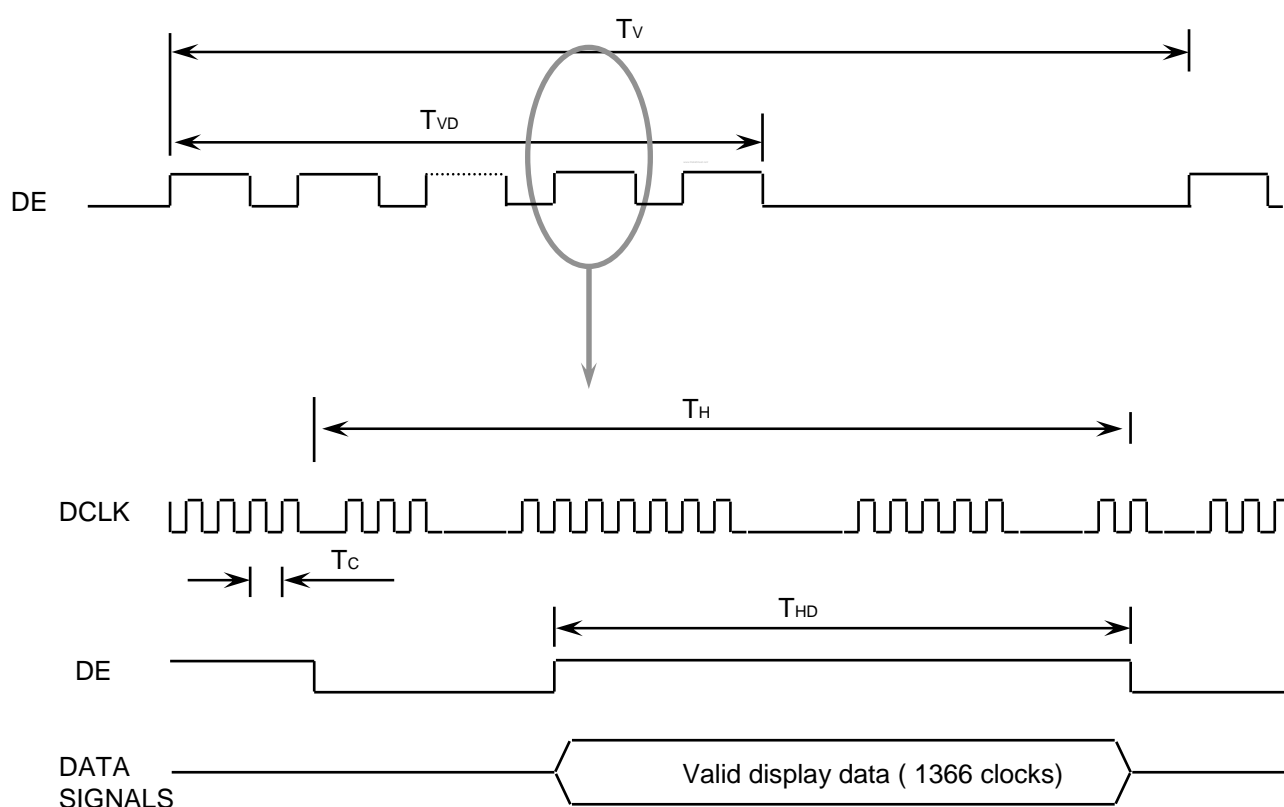

Samsung Secret

6.3 Power ON/OFF Sequence

Approval

: To prevent a latch-up or DC operation of the LCD module, the power on/off sequence should be as the diagram below.

Power ON/OFF Sequence

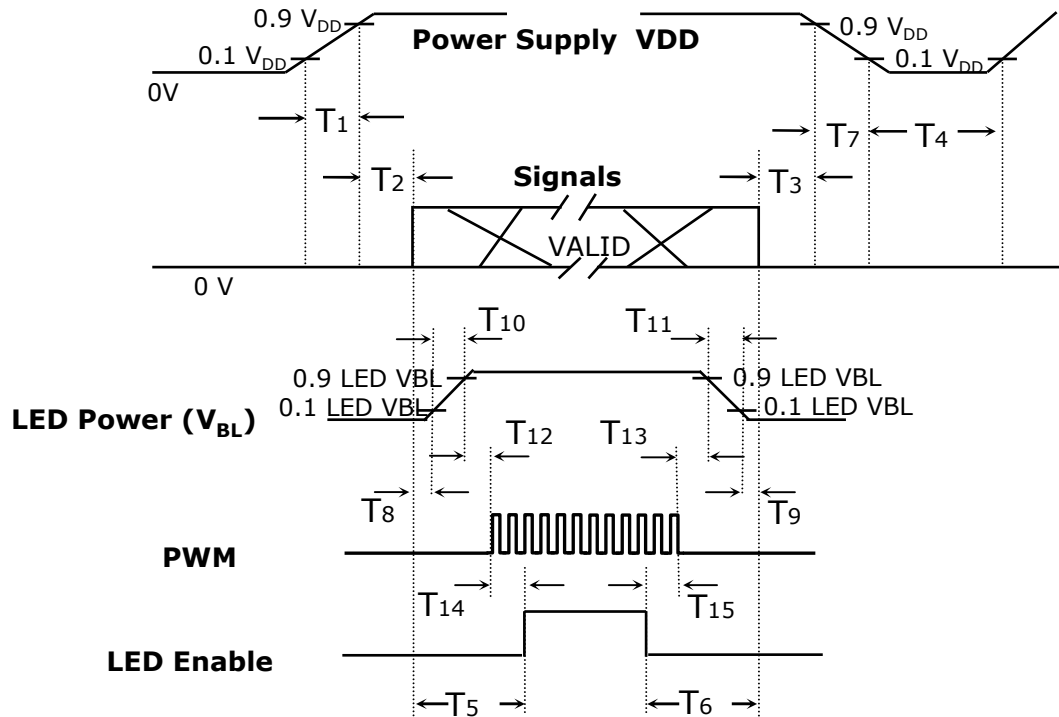

Timing (ms)	Remarks
$0 < T_1 \leq 10$	V _{DD} rising time from 10% to 90%
$0 < T_2 \leq 50$	Delay from V _{DD} to valid data at power ON
$0 < T_3 \leq 50$	Delay from valid data OFF to V _{DD} OFF at power Off
$400 \leq T_4$	V _{DD} OFF time for Windows restart
$200 \leq T_5$	Delay from valid data to LED enable at power ON
$200 \leq T_6$	Delay from valid data off to LED disable at power Off
$0 < T_7 \leq 10$	V _{DD} falling time from 90% to 10%
$0 < T_{10} < 10$	LED VBL rising time from 10% to 90%
$0 < T_{11} < 10$	LED VBL falling time from 90% to 10%
$10 < T_{12}$	Delay from LED driver VBL rising time 90% to PWM ON
$10 < T_{13}$	Delay from PWM Off to LED driver VBL falling time 10%
$0 < T_{14}$	Delay from PWM ON to LED Enable ON
$0 < T_{15}$	Delay from B/L Enable Off to PWM Off

Timing Parameters and definition

Note (1) Regarding the timing of T8 and T9, the following one are recommended

10 < T₈ : Delay from valid data on to LED driver VBL rising time 10%

10 < T₉ : Delay from LED driver VBL falling time 10% to valid data Off

Samsung Secret

7. MECHANICAL OUTLINE DIMENSION

Approval

[Refer to the next page]

Samsung Secret

Doc.No.	LTN156AT14-F01	Rev.No	04-A00-S-100706	Page	21 / 32
----------------	----------------	---------------	-----------------	-------------	---------

NO	PART NAME	CODE NO	SPECIFICATION	Q'TY	WEIGHT		UNFOLDED DIM. OF. MATERIAL	REMARK
					FINISH	MATERIAL		

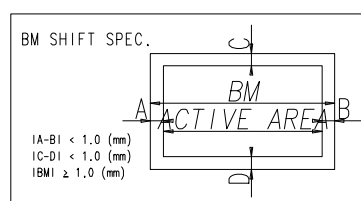
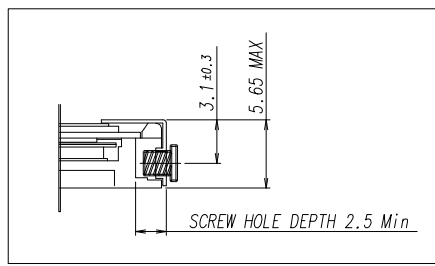
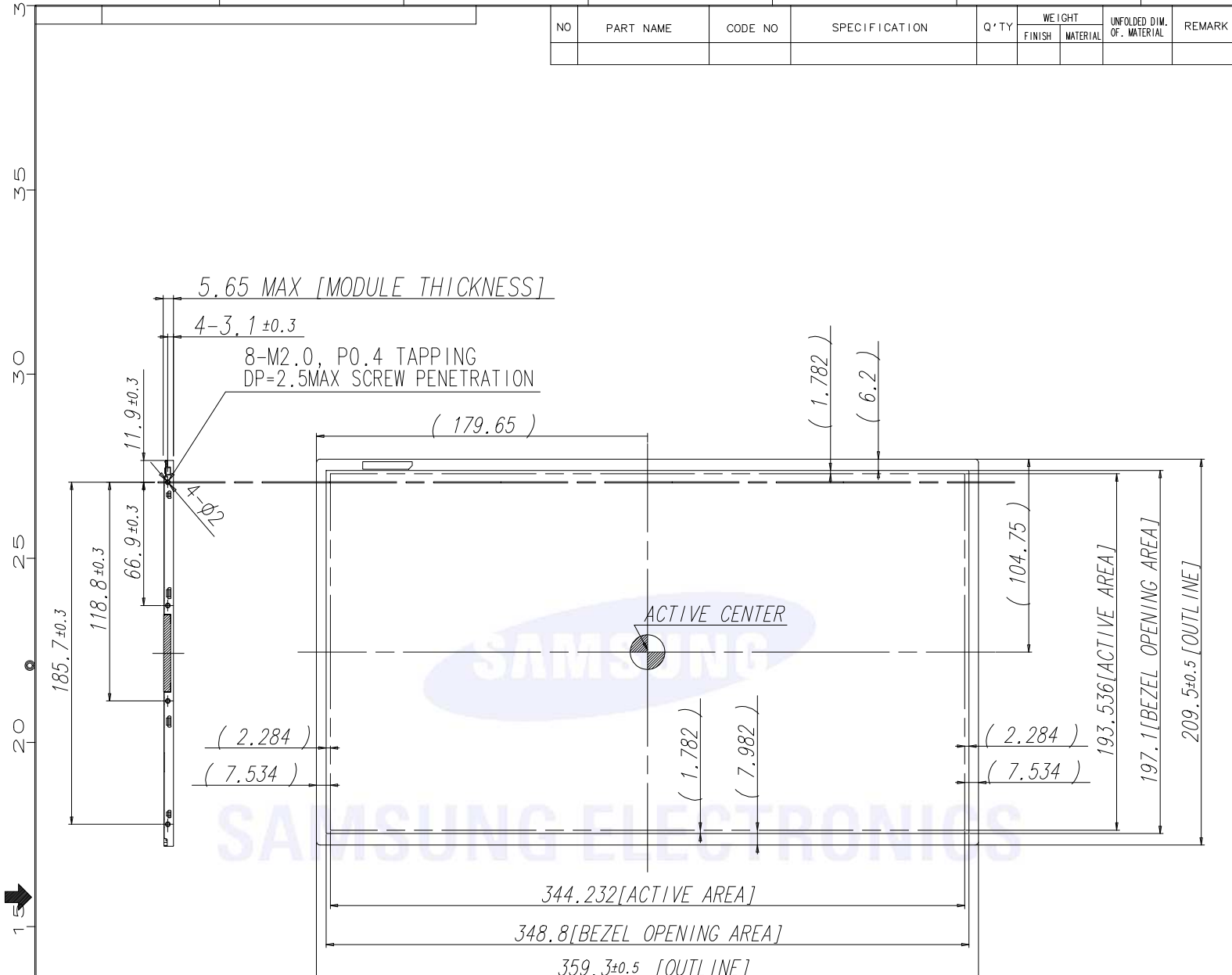

*** NOTE**

- SIGNAL INTERFACE CONNECTOR TO BE SPECIFIED AS BELOW.
 - MAKER : I-PEX (Not accept compotable connector basically)
 - INPUT CONNECTOR : I-PEX 20455-040E-02R
- LED CONNECTOR FOR BACKLIGHT TO BE SPECIFIED AS BELOW.
 - MAKER : UJU Electronics
 - PART NO : 51441-1041
- MAXIMUM SCREW TORQUE : MAX 2.5 Kgf-cm
- WEIGHT : 490 g MAX
- In order to avoid IC damage, it is not allow that overlapping of cables or antennas, camera, WLAN, WWAN over these COF locations.
- Chassis Gap : Max 0.7mm

S-O-S-MR

김현형 02068340개발1그룹(LCD)129250140 20100623153629

REV	DATE	DESCRIPTION OF REVISION				REASON	CHG'D BY	
		UNIT	mm	DRA'N BY	DES'D BY	CHK'D BY	APP'D BY	
		SCALE	0.3		H.H.KIM		J.S.OK	
		TOLERANCE	±0.5		2010.04.15		2010.04.15	
SAMSUNG ELECTRONICS							SPEC. NO	
MODEL NAME		LTN156AT14-N01					PART/SHEET NAME	OUTLINE DIMENSION
CODE NO.							SHEET	1/1
							VER.	000

NO	PART NAME	CODE NO	SPECIFICATION	Q'TY	WEIGHT		UNFOLDED DIM. OF. MATERIAL	REMARK
					FINISH	MATERIAL		

3.5
3.0
2.5
2.0
1.5
1.0
0.5
0

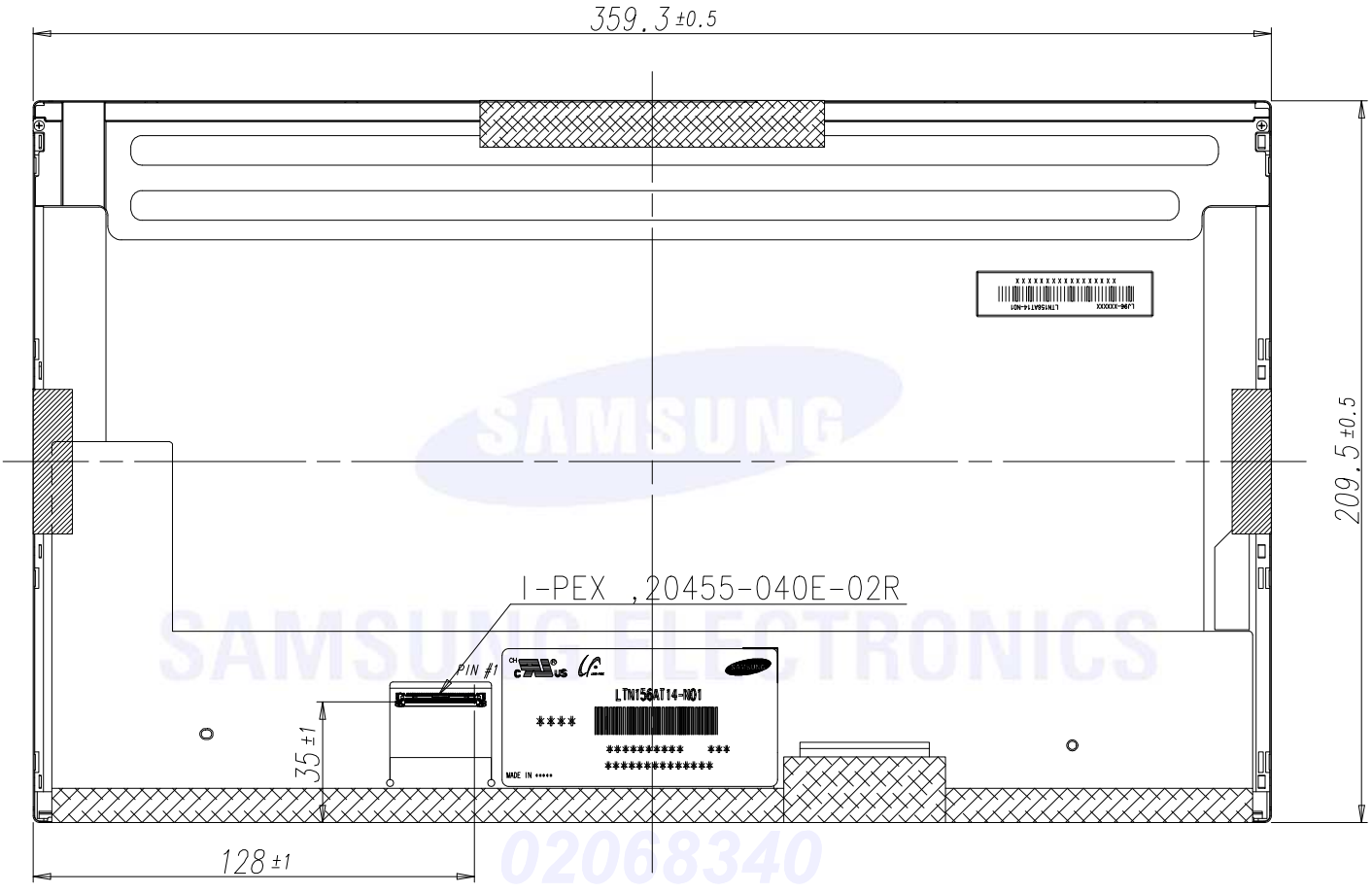

S-O-S-V-F-R

REV	DATE	DESCRIPTION OF REVISION				REASON	CHG'D BY
UNIT	mm	DRA'N BY	DES'D BY	CHK'D BY	APP'D BY	MODEL NAME	LTN156AT14-N01
SCALE	0.3		H.H.KIM		J.S.OK	PART/SHEET NAME	OUTLINE DIMENSION SHEET 1/1
TOLERANCE	± 0.5		2010.04.15		2010.04.15	CODE NO.	VER.
SAMSUNG ELECTRONICS							

8. PACKING

1. CARTON(Internal Package)

(1) Cushion Pad

Corrugated fiberboard box and corrugated cardboard as shock absorber

(2) Packing Method

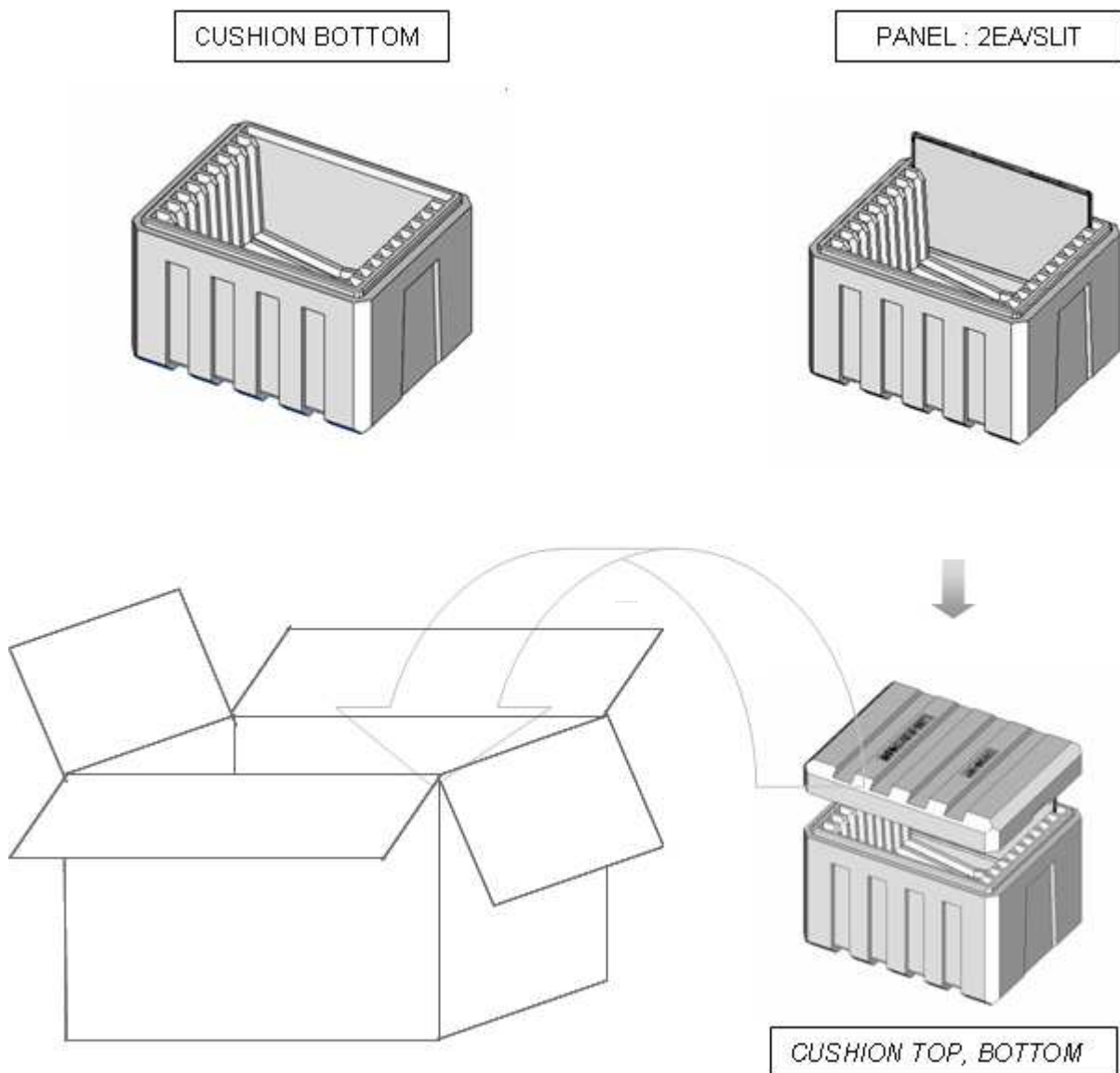

- Note 1) Total Weight : Approximately 15.0 kg
2) Acceptance number of piling : 20 sets
3) Carton size : 344(W) x 432(D) x 329 (H)
4) MAX accumulation quantity : 5 cartons

Samsung Secret

(3)Packing Material

No	Part name	Quantity
1	Static electric protective sack	20
2	Cushion Top Cushion Bottom	1 set
3	Pictorial marking	2 pcs
4	Carton	1 set

(4)Pallet Form

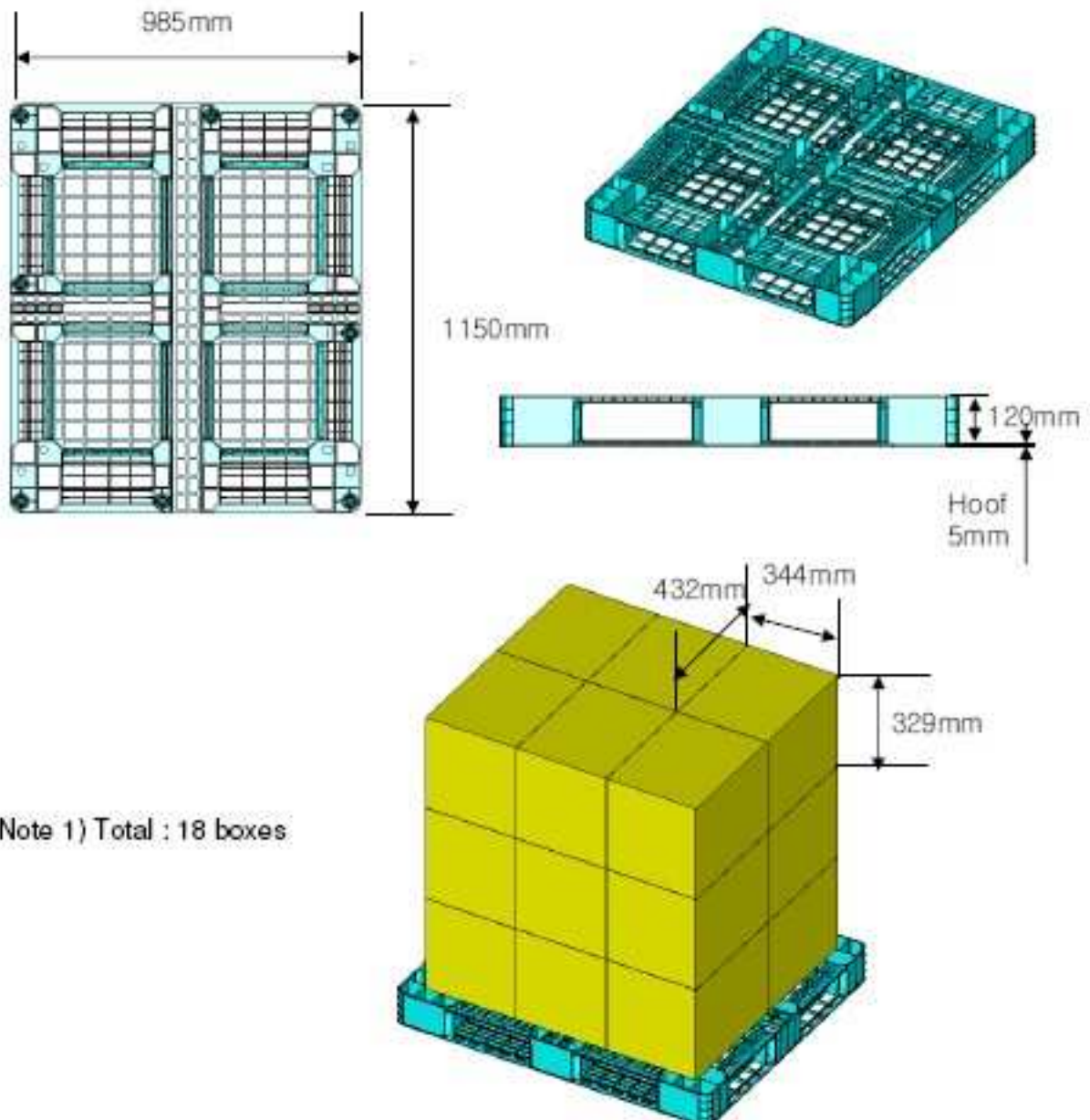

Note 1) Total : 18 boxes

Samsung Secret

9. MARKINGS & OTHERS

A nameplate bearing followed by is affixed to a shipped product at the specified location on each product.

- (1) Parts number : LTN156AT14-F01
- (2) Revision code : 3 letters
- (3) Lot number : X X X X XX XX XX F01

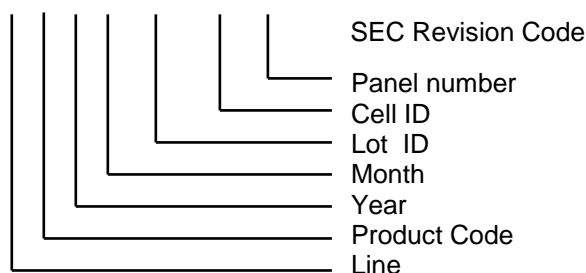

(4) Nameplate Indication

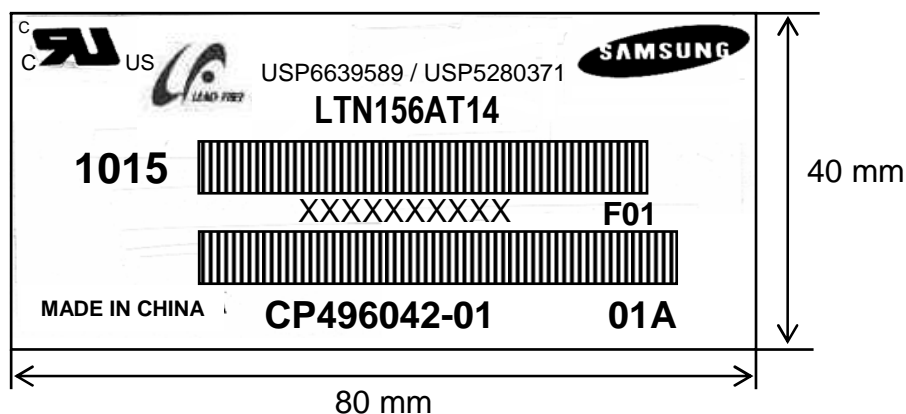

Parts name : LTN156AT14
 Lot number : XXXXXXXXXXXX
 Inspected work week : 1015 (2010 year 15th week)
 Product Revision Code : F01
 US Patents No. : USP6639589 / USP5280371
 Fujitsu's part No. : CP496042-01 01A

High voltage caution label

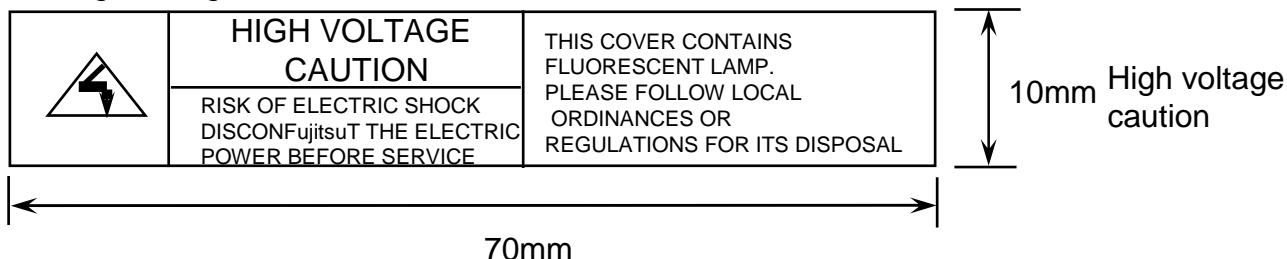

Samsung Secret

(5) Packing small box attach

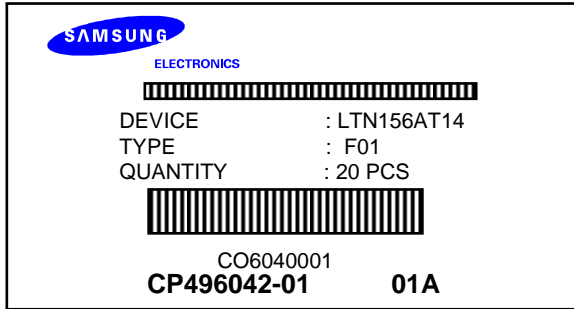

Samsung Secret

10. GENERAL PRECAUTIONS

Approval

1. Handling

- (a) When the module is assembled, It should be attached to the system firmly using every mounting holes. Be careful not to twist and bend the modules.
- (b) Refrain from strong mechanical shock and / or any force to the module. In addition to damage, this may cause improper operation or damage to the module and CCFT back-light.
- (c) Note that polarizers are very fragile and could be easily damaged. Do not press or scratch the surface harder than a HB pencil lead.
- (d) Wipe off water droplets or oil immediately. If you leave the droplets for a long time, Staining and discoloration may occur.
- (e) If the surface of the polarizer is dirty, clean it using some absorbent cotton or soft cloth.
- (f) The desirable cleaners are water, IPA (Isopropyl Alcohol) or Hexane. Do not use Ketone type materials(ex. Acetone), Ethyl alcohol, Toluene, Ethyl acid or Methyl chloride. It might permanent damage to the polarizer due to chemical reaction.
- (g) If the liquid crystal material leaks from the panel, it should be kept away from the eyes or mouth. In case of contact with hands, legs or clothes, it must be washed away thoroughly with soap.
- (h) Protect the module from static, it may cause damage to the C-MOS Gate Array IC.
- (i) Use fingerstalls with soft gloves in order to keep display clean during the incoming inspection and assembly process.
- (j) Do not disassemble the module.
- (k) Do not pull or fold the lamp wire.
- (l) Do not adjust the variable resistor which is located on the back side.
- (m) Protection film for polarizer on the module shall be slowly peeled off just before use so that the electrostatic charge can be minimized.
- (n) Pins of I/F connector shall not be touched directly with bare hands.

Samsung Secret

Doc.No.	LTN156AT14-F01	Rev.No	04-A00-S-100706	Page	28 / 32
----------------	----------------	---------------	-----------------	-------------	---------

2. STORAGE

- (a) Do not leave the module in high temperature, and high humidity for a long time.
It is highly recommended to store the module with temperature from 0 to 35 °C and relative humidity of less than 70%.
- (b) Do not store the TFT-LCD module in direct sunlight.
- (c) The module shall be stored in a dark place. It is prohibited to apply sunlight or fluorescent light during the store.

3. OPERATION

- (a) Do not connect/disconnect the module in the “ Power On” condition.
- (b) Power supply should always be turned on/off by following item 6.3
“ Power on/off sequence “.
- (c) Module has high frequency circuits. Sufficient suppression to the electromagnetic interference shall be done by system manufacturers. Grounding and shielding methods may be important to minimize the interference.
- (d) The cable between the back-light connector and its inverter power supply shall be a minimized length and be connected directly . The longer cable between the back-light and the inverter may cause lower luminance of lamp(CCFT) and may require higher startup voltage (Vs).
- (e) The standard limited warranty is only applicable when the module is used for general notebook applications. If used for purposes other than as specified, SEC is not to be held reliable for the defective operations. It is strongly recommended to contact SEC to find out fitness for a particular purpose.
- (f) When you connect a signal cable to LCD, remove an AC adapter by all means.
In addition, to connect with keep the correct sequence, not to occur the short by left voltage.

4. OTHERS

- (a) Ultra-violet ray filter is necessary for outdoor operation.
- (b) Avoid condensation of water. It may result in improper operation or disconnection of electrode.
- (c) Do not exceed the absolute maximum rating value. (the supply voltage variation, input voltage variation, variation in part contents and environmental temperature, so on)
Otherwise the module may be damaged.
- (d) If the module displays the same pattern continuously for a long period of time, it can be the situation when the image “sticks” to the screen.
- (e) This module has its circuitry PCB's on the rear side and should be handled carefully in order not to be stressed.

Samsung Secret

11. EDID

Approval

Address (HEX)	FUNCTION	Value	BIN	DEC	ASCII or Data	Notes	
		HEX					
00	Header	00	00000000	0		EDID Header	
01		FF	11111111	255			
02		FF	11111111	255			
03		FF	11111111	255			
04		FF	11111111	255			
05		FF	11111111	255			
06		FF	11111111	255			
07		00	00000000	0			
08	ID Manufacturer Name	4C	01001100	76	S	3 character ID	
					E		
09			A3	10100011	163	C	"SEC"
0A	ID Product Code	34	00110100	52	[4]		
0B			46	01000110	70	[F]	
0C	32-bit serial no.	00	00000000	0			
0D			00	00000000	0		
0E			00	00000000	0		
0F			00	00000000	0		
10	Week of manufacture	00	00000000	0			
11	Year of manufacture	14	00010100	20	2010	2010	
12	EDID Structure Ver.	01	00000001	1	1	EDID Ver. 1.0	
13	EDID revision #	03	00000011	3	3	EDID Rev. 3	
14	Video input definition	80	10000000	128			
15	Max H image size	22	00100010	34	34	34 cm(approx)	
16	Max V image size	13	00010011	19	19	19 cm(approx)	
17	Display Gamma	78	01111000	120	2.2	Gamma 2.2	
18	Feature support	0A	00001010	10			
19	Red/green low bits	89	10001001	137		10000111	
1A	Blue/white low bits	A5	10100101	165		11111110	
1B	Red x/ high bits	9D	10011101	157	0.615	Red x 0.615= 10011101	
1C	Red y	5B	01011011	91	0.355	Red y 0.355= 01011000	
1D	Green x	54	01010100	84	0.330	Green x 0.330= 01010101	
1E	Green y	9C	10011100	156	0.610	Green y 0.610= 10011100	
1F	Blue x	26	00100110	38	0.150	Blue x 0.150= 00100110	
20	Blue y	19	00011001	25	0.100	Blue y 0.100= 00011001	
21	White x	50	01010000	80	0.313	White x 0.313= 01010000	
22	White y	54	01010100	84	0.329	White y 0.329= 01010100	
23	Established timing 1	00	00000000	0			
24	Established timing 2	00	00000000	0			
25	Established timing 3	00	00000000	0			
26	Standard timing #1	01	00000001	1		not used	
27			01	00000001	1		
28	Standard timing #2	01	00000001	1		not used	
29			01	00000001	1		
2A	Standard timing #3	01	00000001	1		not used	
2B			01	00000001	1		
2C	Standard timing #4	01	00000001	1		not used	
2D			01	00000001	1		
2E	Standard timing #5	01	00000001	1		not used	
2F			01	00000001	1		
30	Standard timing #6	01	00000001	1		not used	
31			01	00000001	1		
32	Standard timing #7	01	00000001	1		not used	
33			01	00000001	1		
34	Standard timing #8	01	00000001	1		not used	
35			01	00000001	1		

Samsung Secret

36	Detailed timing/monitor descriptor #1	83	10000011	131	75.55	Main clock= 75.55 MHz	
37		1D	00011101	29			
38		56	01010110	86	1366	Hor active=1366 pixels	
39		E8	11101000	232	232	Hor blanking=232 pixels	
3A		50	01010000	80		4bit : 4bit	
3B		00	00000000	0	768	Vertical active=768 lines	
3C		14	00010100	20	20	Vertical blanking=20 lines	
3D		30	00110000	48		4bit : 4bit	
3E		30	00110000	48	48		
3F		20	00100000	32	32	H sync. Width=32 pixels	
40		25	00100101	37	2 5	V sync. Offset=2 lines V sync. Width=5 lines	
41		00	00000000	0		2bit : 2bit : 2bit : 2bit	
42		58	01011000	88	344	H image size= 344 mm(approx)	
43		C1	11000001	193	193	V image size = 193 mm(approx)	
44		10	00010000	16			
45		00	00000000	0		No Horizontal Border	
46		00	00000000	0		No Vertical Border	
47		19	00011001	25			
48		Detailed timing/monitor descriptor #2	00	00000000	0		Manufacturer Specified (Timing)
49	00		00000000	0			
4A	00		00000000	0			
4B	0F		00001111	15			
4C	00		00000000	0			
4D	00		00000000	0			
4E	00		00000000	0		Value=HSPWmin / 2	
4F	00		00000000	0		Value=HSPWmax / 2	
50	00		00000000	0		Value=Thbpmin / 2	
51	00		00000000	0		Value=Thbpmax / 2	
52	00		00000000	0		Value=VSPWmin / 2	
53	00		00000000	0		Value=VSPWmax / 2	
54	00		00000000	0		Value=TVbpmin / 2	
55	00		00000000	0		Value=TVbpmax / 2	
56	1E		00011110	30		Thpmin=value*2 + HA pixelClks	
57	B4		10110100	180		Thpmax=value*2 + HA pixelClks	
58	02		00000010	2		Tvpmin=value*2 + VA lines	
59	74		01110100	116		Tvpmax=value*2 + VA lines	
5A	00		00000000	0		Module revision	
5B	00	00000000	0		ASCII Data String Tag		
5C	00	00000000	0				
5D	FE	11111110	254				
5E	00	00000000	0				
5F	53	01010011	83	[S]			
60	41	01000001	65	[A]			
61	4D	01001101	77	[M]			
62	53	01010011	83	[S]			
63	55	01010101	85	[U]			
64	4E	01001110	78	[N]			
65	47	01000111	71	[G]			
66	0A	00001010	10	[*]			
67	20	00100000	32	[]			
68	20	00100000	32	[]			
69	20	00100000	32	[]			
6A	20	00100000	32	[]			
6B	20	00100000	32	[]			

Samsung Secret

6C		00	00000000	0		Monitor Name Tag (ASCII)
6D		00	00000000	0		
6E		00	00000000	0		
6F		FE	11111110	254		
70		00	00000000	0		
71	Detailed timing/monitor descriptor #4	31	00110001	49	[1]	
72		35	00110101	53	[5]	
73		36	00110110	54	[6]	
74		41	01000001	65	[A]	
75		54	01010100	84	[T]	
76		31	00110001	49	[1]	
77		34	00110100	52	[4]	
78		2D	00101101	45	[-]	
79		46	01000110	70	[F]	
7A		30	00110000	48	[0]	
7B		31	00110001	49	[1]	
7C		0A	00001010	10	[*]	
7D		20	00100000	32	[]	
7E		Extension Flag	00	00000000	0	
7F	Checksum	6D	01101101	109		

Samsung Secret