

**SAMSUNG****ELECTRONICS**

Approval

TO : General  
 DATE : June 21. 2011

**SAMSUNG TFT-LCD****MODEL NO : LTN156AT17-W**

NOTE : Extension code [ -W ]  
 → LTN156AT17-W  
 Surface type [ Anti-Glare]

*The information described in this SPEC is preliminary and can be changed without prior notice.*

APPROVED BY :

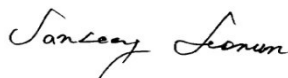
PREPARED BY : **LCD Application Engineering Group****SAMSUNG ELECTRONICS CO., LTD.****Samsung Secret**

<b>Doc.No.</b>	LTN156AT17-W	<b>Rev.No</b>	04-A00-G-110621	<b>Page</b>	1 / 27
----------------	--------------	---------------	-----------------	-------------	--------

Approval

**CONTENTS**

Revision History	-----	( 3 )
General Description	-----	( 4 )
1. Absolute Maximum Ratings	-----	( 5 )
1.1 Absolute Ratings of environment		
1.2 Electrical Absolute Ratings		
2. Optical Characteristics	-----	( 7 )
3. Electrical Characteristics	-----	( 10 )
3.1 TFT LCD Module		
3.2 Backlight Unit		
3.3 LED Driver		
4. Block Diagram	-----	( 13 )
4.1 TFT LCD Module		
5. Input Terminal Pin Assignment	-----	( 15 )
5.1 Input Signal & Power		
5.2 LVDS Interface		
5.3 Timing Diagrams of LVDS For Transmitting		
5.4 Input Signals, Basic Display Colors and Gray Scale of Each Color.		
5.5 Pixel format		
6. Interface Timing	-----	( 21 )
6.1 Timing Parameters		
6.2 Timing Diagrams of interface Signal		
6.3 Power ON/OFF Sequence		
7. Outline Dimension	-----	( 23 )
8. Packing	-----	( 24 )
9. Markings & Others	-----	( 25 )
10. General Precautions	-----	( 26 )

**Samsung Secret**

**REVISION HISTORY**

Approval

Date	Revision No.	Page	Summary
June, 21. 2011	A00	All	LTN156AT17-W General model approval spec was issued.

**Samsung Secret**

<b>Doc.No.</b>	LTN156AT17-W	<b>Rev.No</b>	04-A00-G-110621	<b>Page</b>	3 / 27
----------------	--------------	---------------	-----------------	-------------	--------

Approval

## GENERAL DESCRIPTION

### DESCRIPTION

LTN156AT17-W is a color active matrix TFT (Thin Film Transistor) liquid crystal display (LCD) that uses amorphous silicon TFT as switching devices. This model is composed of a TFT LCD panel, a driver circuit and a backlight system. The resolution of a 15.6" contains 1366 x 768 pixels and can display up to 262,144 colors. 6 O'clock direction is the Optimum viewing angle.

### FEATURES

- 1366 x 768 pixels resolution (16:9)
- Fast Response Time
- Low power consumption
- LED BLU Structure
- DE (Data enable) only mode
- 3.3V LVDS Interface
- On board EDID chip
- RoHS compliance
- PVC free compliance
- BFR free compliance
- As free compliance

### APPLICATIONS

- Notebook PC
- If the usage of this product is not for PC application, but for others, please contact SEC

## GENERAL INFORMATION

Item	Specification	Unit	Note
Display area	344.232 (H) x 193.536 (V) (15.6"diagonal)	mm	
Driver element	a-Si TFT active matrix		
Display colors	262,144		
Number of pixel	1366 x 768	pixel	16 : 9
Pixel arrangement	RGB vertical stripe		
Pixel pitch	0.252 (H) x 0.252 (V) (TYP.)	mm	
Display Mode	Normally white		
Surface treatment	Haze 25%, Hardness 3H		Anti-Glare

**Samsung Secret**

<b>Doc.No.</b>	LTN156AT17-W	<b>Rev.No</b>	04-A00-G-110621	<b>Page</b>	4 / 27
----------------	--------------	---------------	-----------------	-------------	--------

Approval

## Mechanical Information

Item		Min.	Typ.	Max.	Unit	Note
Module size	Horizontal (H)	358.8	359.3	359.8	mm	
	Vertical (V)	209.0	209.5	210.0	mm	
	Depth (D)	-	-	5.5	mm	(1)
Weight		-	-	470	g	

Note (1) Measurement condition of outline dimension  
 . Equipment : Vernier Calipers  
 . Push Force : 500g · f (minimum)

## 1. ABSOLUTE MAXIMUM RATINGS

## 1.1 ENVIRONMENTAL ABSOLUTE RATINGS

Item	Symbol	Min.	Max.	Unit	Note
Storage temperate	TSTG	-20	60	°C	(1)
Operating temperate (Temperature of glass surface)	TOPR	0	50	°C	(1)
Shock ( non-operating )	Snop	-	240	G	(2),(4)
Vibration (non-operating)	Vnop	-	2.41	G	(3),(4)

Note (1) Temperature and relative humidity range are shown in the figure below.  
 95 % RH Max. ( $40\text{ °C} \geq T_a$ )  
 Maximum wet - bulb temperature at  $39\text{ °C}$  or less. ( $T_a > 40\text{ °C}$ ) No condensation

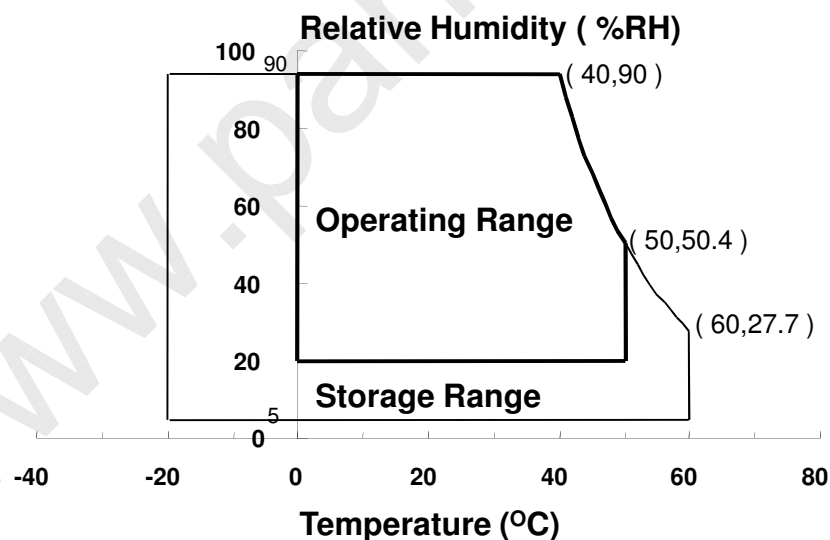

- (2) 2ms, half sine wave, one time for  $\pm X, \pm Y, \pm Z$ .  
 (3) 5 - 500 Hz, random vibration, 30min for X, Y, Z.  
 (4) At testing Vibration and Shock, the fixture in holding the Module to be tested have to be hard and rigid enough so that the Module would not be twisted or bent by the fixture.

Samsung Secret

Approval

## 1.2 ELECTRICAL ABSOLUTE RATINGS

## (1) TFT LCD MODULE

 $V_{DD} = 3.3V, V_{SS} = GND = 0V$ 

Item	Symbol	Min.	Max.	Unit	Note
Power Supply Voltage	$V_{DD}$	$V_{DD} - 0.3$	$V_{DD} + 0.3$	V	(1)
Logic Input Voltage	$V_{DD}$	$V_{DD} - 0.3$	$V_{DD} + 0.3$	V	(1)

Note (1) Within  $T_a$  ( $25 \pm 2$  °C )

Samsung Secret

Doc.No.

LTN156AT17-W

Rev.No

04-A00-G-110621

Page

6 / 27

Approval

## 2. OPTICAL CHARACTERISTICS

The following items are measured under stable conditions. The optical characteristics should be measured in a dark room or equivalent state with the methods shown in Note (5).  
Measuring equipment : TOPCON SR-3

\*Ta = 25 ± 2 °C, VDD=3.3V, fv= 60Hz, fdCLK = 76.69 MHz, IL = 27 mA

Item	Symbol	Condition	Min.	Typ.	Max	Unit	Note	
Contrast Ratio (5 Points)	CR	Normal Viewing Angle $\phi = 0$ $\theta = 0$	300	-	-	-	(1), (2), (5)	
Response Time at Ta ( Rising + Falling )	T <sub>RT</sub>		-	16	25	msec	(1), (3)	
Average Luminance of White (5 Points)	Y <sub>L,AVE</sub>		180	220	-	cd/m <sup>2</sup>	I <sub>L</sub> =27mA (1), (4)	
Color Chromaticity ( CIE )	Red		R <sub>X</sub>	0.580	0.615	0.645	-	
			R <sub>Y</sub>	0.327	0.355	0.385		
	Green		G <sub>X</sub>	0.305	0.335	0.365		
			G <sub>Y</sub>	0.580	0.610	0.640		
	Blue		B <sub>X</sub>	0.120	0.150	0.180		
			B <sub>Y</sub>	0.070	0.100	0.130		
	White		W <sub>X</sub>	0.283	0.313	0.343		
		W <sub>Y</sub>	0.299	0.329	0.359			
Viewing Angle	Hor.	$\theta_L$	40	-	-	Degrees	(1), (5) SR-3	
		$\theta_R$	40	-	-			
	Ver.	$\phi_H$	10	-	-			
		$\phi_L$	30	-	-			
Color Gamut			-	60	-	%		
13 Points White Variation	$\delta_L$		-	-	1.7	-	(6)	

**Samsung Secret**

Doc.No.

LTN156AT17-W

Rev.No

04-A00-G-110621

Page

7 / 27

Approval

Note 1) Definition of Viewing Angle : Viewing angle range( $10 \leq C/R$ )

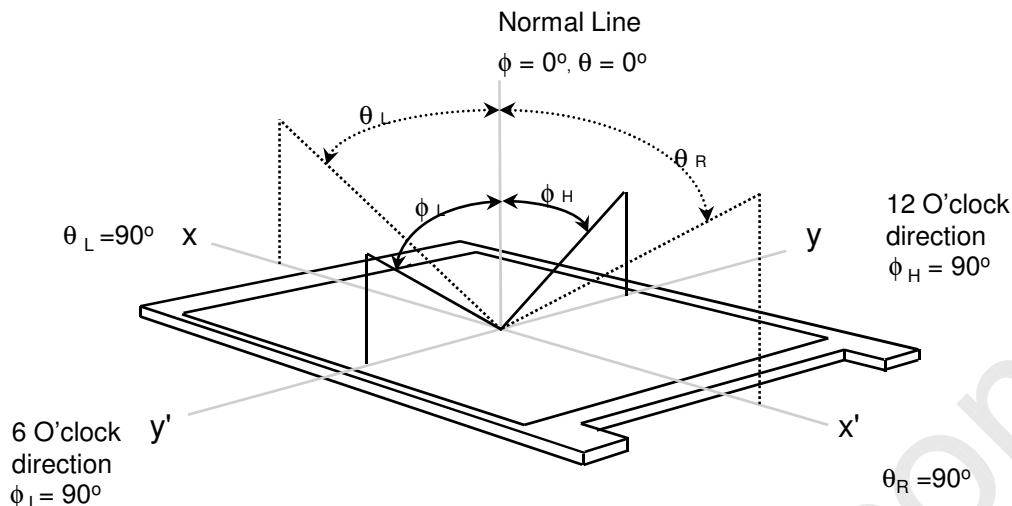

Note 2) Definition of Contrast Ratio (CR) : Ratio of gray max (Gmax) ,gray min (Gmin) at 5 points(4, 5, 7, 9, 10)

$$CR = \frac{CR(4) + CR(5) + CR(7) + CR(9) + CR(10)}{5}$$

Points : (4) , (5) , (7) , (9) , (10) at the figure of Note (6).

Note 3) Definition of Response time :

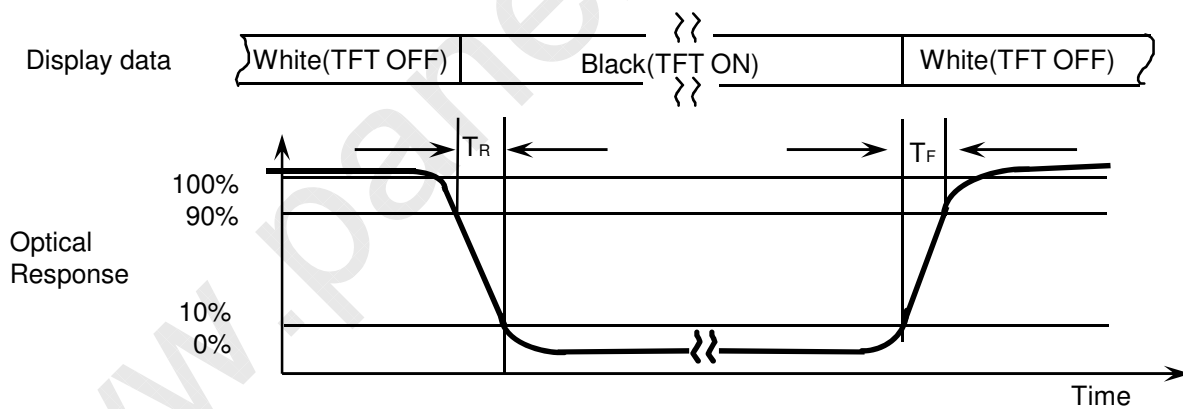

Note 4) Definition of Average Luminance of White : measure the luminance of white at 5 points.

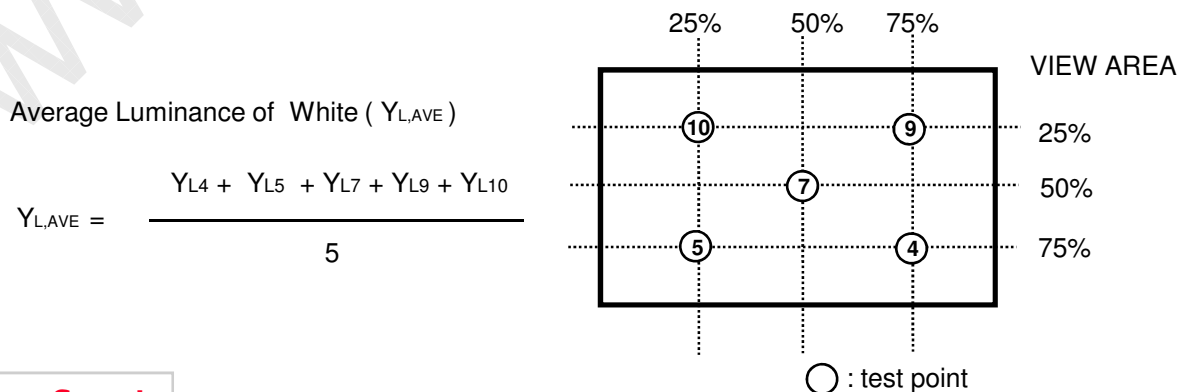

**Samsung Secret**



Approval

Note 5) After stabilizing and leaving the panel alone at a given temperature for 30 min , the measurement should be executed. Measurement should be executed in a stable, windless, and dark room. 30 min after lighting the backlight. This should be measured in the center of screen.  
 LED current : 27 mA, Duty 100%  
 Environment condition : Ta = 25 ± 2 °C, Dark room, No wind, No artificial vibration

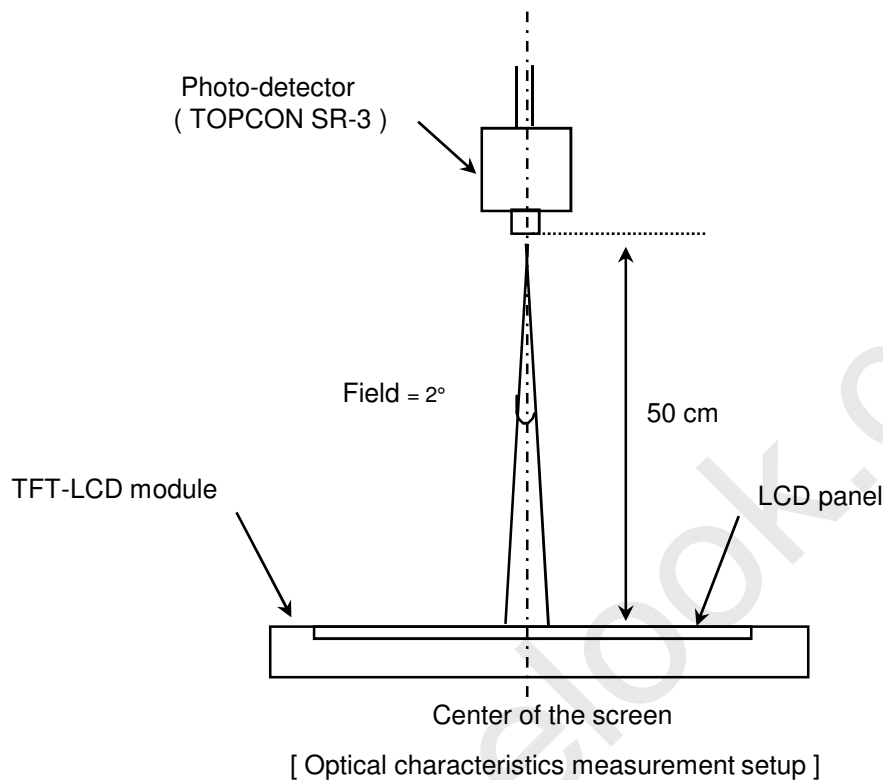

Note 6) Definition of 13 points white variation ( $\delta L$ ), [ ① ~ ⑬ ]

$$\delta L = \frac{\text{Maximum luminance of 13 points}}{\text{Minimum luminance of 13 points}}$$

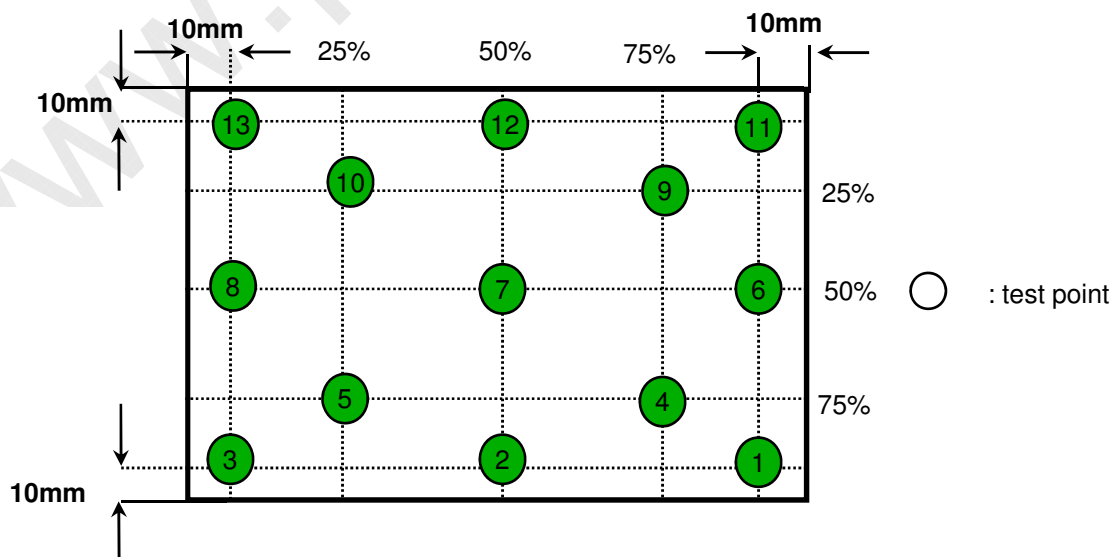

**Samsung Secret**

<b>Doc.No.</b>	LTN156AT17-W	<b>Rev.No</b>	04-A00-G-110621	<b>Page</b>	9 / 27
----------------	--------------	---------------	-----------------	-------------	--------

Approval

### 3. ELECTRICAL CHARACTERISTICS

#### 3.1 TFT LCD MODULE

Ta= 25 ± 2°C

Item	Symbol	Min.	Typ.	Max.	Unit	Note	
Voltage of Power Supply	V <sub>DD</sub>	3.0	3.3	3.6	V		
Differential Input Voltage for LVDS Receiver Threshold	High	V <sub>IH</sub>	-	-	+100	mV	V <sub>CM</sub> = +1.2V
	Low	V <sub>IL</sub>	-100	-	-	mV	
Vsync Frequency	f <sub>v</sub>	-	60	-	Hz		
Hsync Frequency	f <sub>H</sub>	-	97.08	-	KHz		
Main Frequency	f <sub>DCLK</sub>	-	76.69	-	MHz		
Rush Current	I <sub>RUSH</sub>	-	-	1.5	A	(4)	
Current of Power Supply	White	I <sub>DD</sub>	-	250	-	mA	(2),(3)*a
	Mosaic		-	370	424	mA	(2),(3)*b

Note (1) Display data pins and timing signal pins should be connected.( GND = 0V )

(2) f<sub>v</sub> = 60Hz, f<sub>DCLK</sub> = 76.69 MHz, V<sub>DD</sub> = 3.3V , DC Current.

(3) Power dissipation pattern

\*a) White Pattern

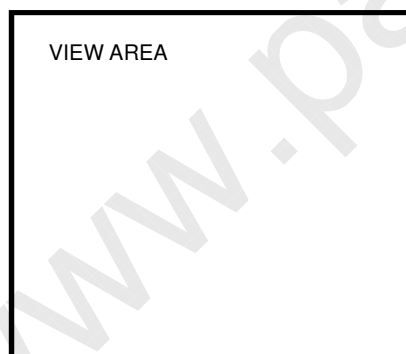

\*b) Mosaic Pattern

Display Brightest Gray Level →

Display Darkest Gray Level →

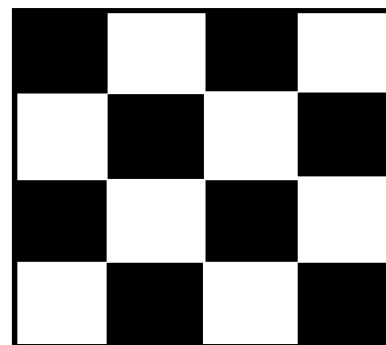

**Samsung Secret**

Doc.No.

LTN156AT17-W

Rev.No

04-A00-G-110621

Page

10 / 27

Approval

## 4) Rush current measurement condition

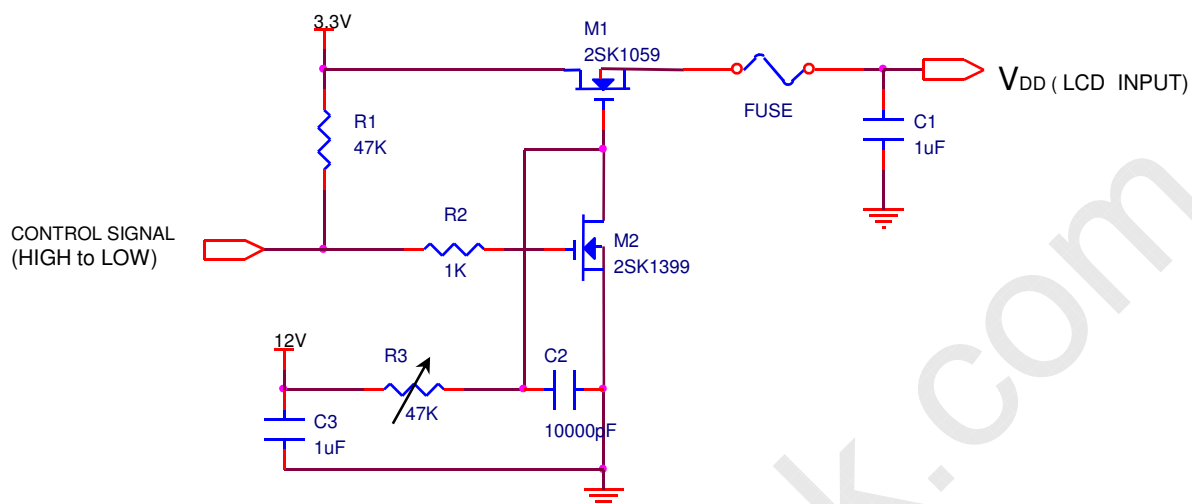
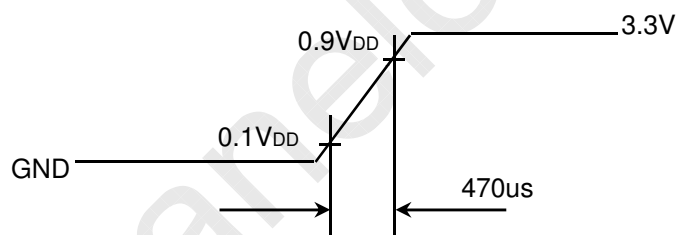
V<sub>DD</sub> rising time is 470us

Samsung Secret

Doc.No.

LTN156AT17-W

Rev.No

04-A00-G-110621

Page

11 / 27

Approval

## 3.2 BACK-LIGHT UNIT

Ta= 25 ± 2 °C

Item	Symbol	Min.	Typ.	Max.	Unit	Note
LED Forward Current	IF	-	20	-	mA	
LED Forward Voltage	VF	3.0	-	3.4	V	
LED Array Voltage	VP	24	-	27.2	V	VF X 9 LEDs
Power Consumption	P	-	-	4.5	W	IF X VF X 36 LEDs (w/o Converter)

## 3.3 LED Driver

- LED Driver Manufacturer : Richtek

Ta= 25 ± 2 °C

Item	Symbol	Min.	Typ.	Max.	Unit	Note
Input Voltage	V <sub>in</sub>	6	12	24	V	
Input Current	I	-	108	-	mA	Max.MOSFET curent in PM6600
Output PWM Frequency	F <sub>PWM</sub>	500	-	2000	kHz	No output PWM
Burst Ratio	D	10	-	100	%	PWM freq : 200Hz~10KHz
External PWM Dimming Control Frequency (BLIM)	F <sub>BLIM</sub>	200Hz	-	10KHz	kHz	BLIM=PWM 0V~3.3V
Output Power	P <sub>out</sub>	-	-	2.3	W	BLIM=100%

Note - Test Equipment : Fluke 45

Samsung Secret

Approval

### 4. BLOCK DIAGRAM

#### 4.1 TFT LCD Module

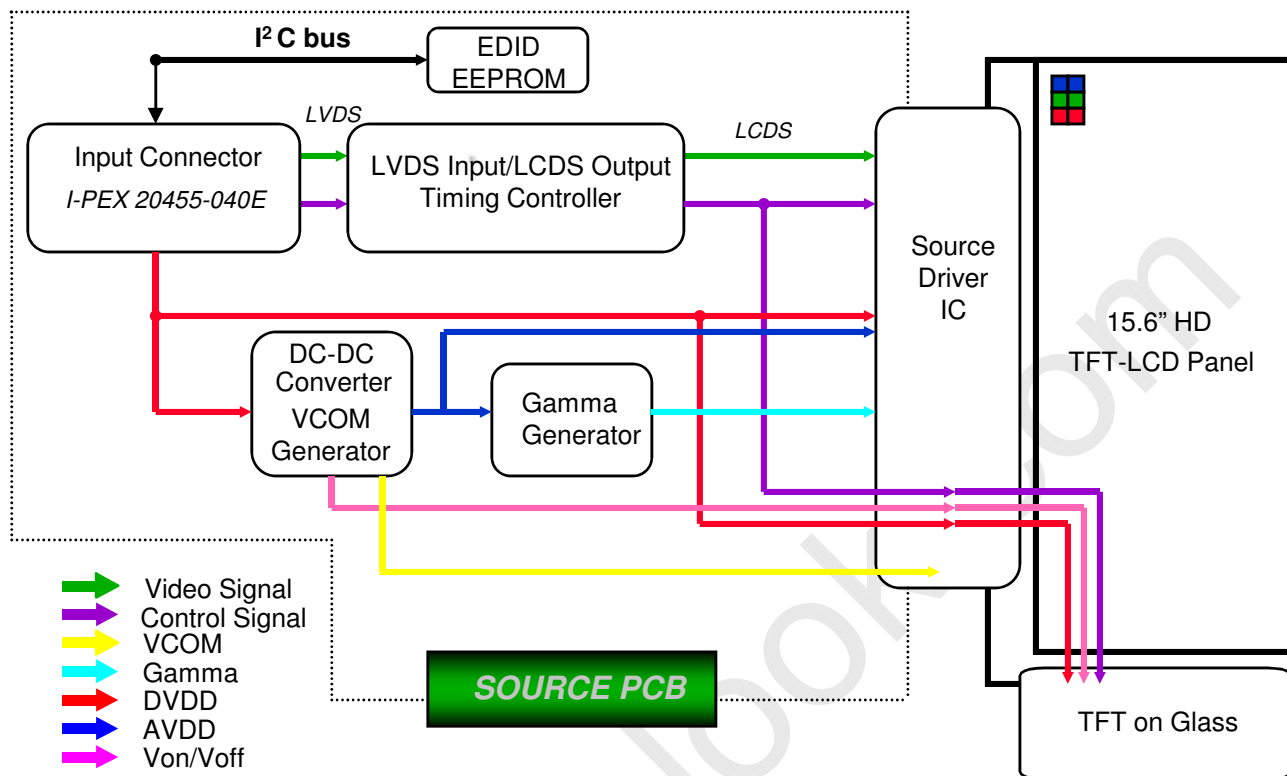

**Samsung Secret**

<b>Doc.No.</b>	LTN156AT17-W	<b>Rev.No</b>	04-A00-G-110621	<b>Page</b>	13 / 27
----------------	--------------	---------------	-----------------	-------------	---------

Doc.No.	LTN156AT17-W	Rev.No	04-A00-G-110621	Page	14 / 27
---------	--------------	--------	-----------------	------	---------

**Samsung Secret**

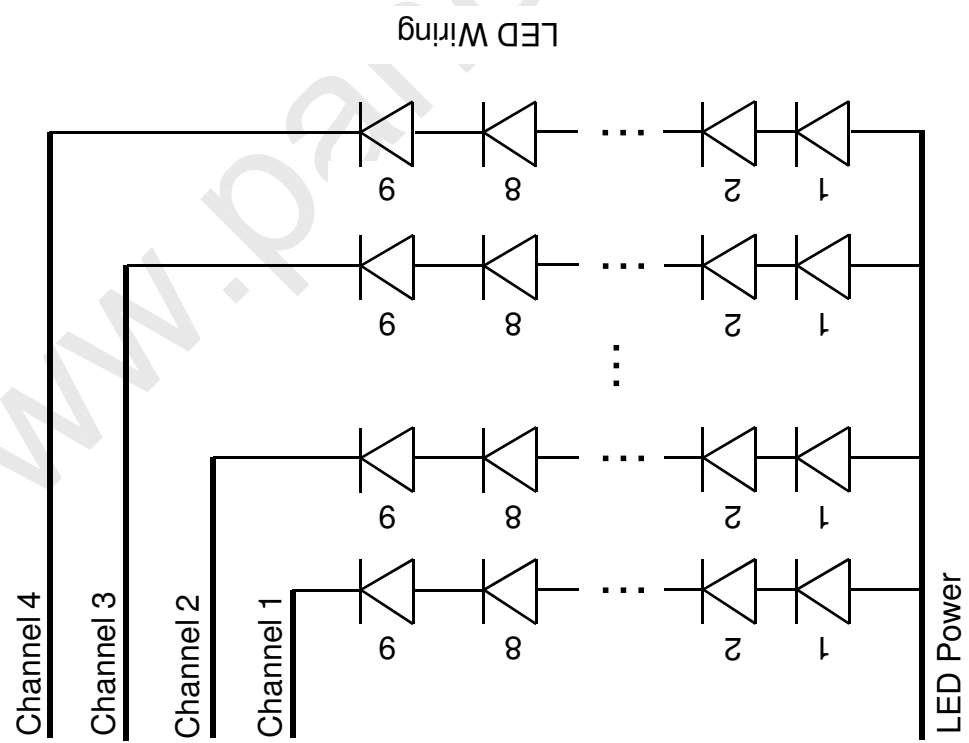
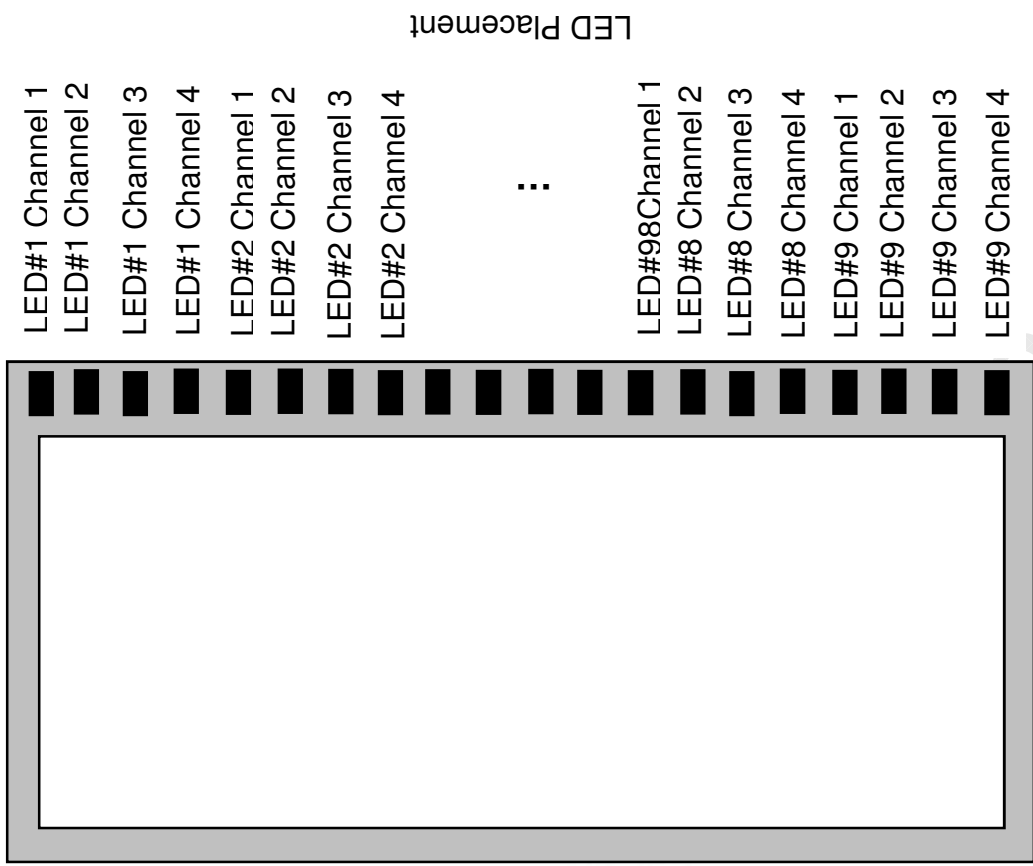

4.2 LED connection and placement

### 4. BLOCK DIAGRAM

Approval

Approval

## 5. INPUT TERMINAL PIN ASSIGNMENT

### 5.1. Input Signal & Power (LVDS, Connector : I-PEX 20455-040E )

PIN #	Symbol	Description
1	NC	No connection
2	VDD	Power Supply, 3.3 V (typical)
3	VDD	Power Supply, 3.3 V (typical)
4	V EEDID	DDC 3.3V power
5	NC	No connection
6	Clk EEDID	DDC Clock
7	DATA EEDID	DDC Data
8	Odd_Rin0-	- LVDS differential data input (R0-R5, G0) (odd pixels)
9	Odd_Rin0+	+ LVDS differential data input (R0-R5, G0) (odd pixels)
10	VSS	Ground – Shield
11	Odd_Rin1-	- LVDS differential data input (G1-G5, B0-B1) (odd pixels)
12	Odd_Rin1+	+ LVDS differential data input (G1-G5, B0-B1) (odd pixels)
13	VSS	Ground – Shield
14	Odd_Rin2-	- LVDS differential data input (B2-B5, HS, VS, DE) (odd pixels)
15	Odd_Rin2+	+ LVDS differential data input (B2-B5, HS, VS, DE) (odd pixels)
16	VSS	Ground – Shield
17	Odd_ClkIN-	- LVDS differential clock input (odd pixels)
18	Odd_ClkIN+	+ LVDS differential clock input (odd pixels)
19	NC	No connection
20	NC	No connection
21	NC	No connection
22	NC	No connection
23	NC	No connection
24	NC	No connection
25	NC	No connection

**Samsung Secret**

<b>Doc.No.</b>	LTN156AT17-W	<b>Rev.No</b>	04-A00-G-110621	<b>Page</b>	15 / 27
----------------	--------------	---------------	-----------------	-------------	---------

Approval

## 5. INPUT TERMINAL PIN ASSIGNMENT

### 5.1. Input Signal & Power (LVDS, Connector : I-PEX 20455-040E )

PIN #	Symbol	Description
26	NC	No connection
27	NC	No connection
28	NC	No connection
29	NC	No connection
30	NC	No connection
31	VSSLED	Ground – LED
32	VSSLED	Ground – LED
33	VSSLED	Ground – LED
34	NC	No connection
35	PWM	System PWM Signal Input (+3.3V Swing)
36	LED_EN	LED enable pin (+3.3V Input)
37	NC	NC
38	VDDLED	7.5V – 21V LED power
39	VDDLED	7.5V – 21V LED power
40	VDDLED	7.5V – 21V LED power

**Samsung Secret**



Approval

## 5.2 LVDS Interface : Transmitter DS90CF363 or Compatible

Pin No.	Name	RGB Signal	Pin No.	Name	RGB Signal
51	TxIN0	R0	14	TxIN14	G5
52	TxIN1	R1	15	TxIN15	B0
54	TxIN2	R2	19	TxIN18	B1
55	TxIN3	R3	20	TxIN19	B2
56	TxIN4	R4	22	TxIN20	B3
3	TxIN6	R5	23	TxIN21	B4
4	TxIN7	G0	24	TxIN22	B5
6	TxIN8	G1	27	TxIN24	Hsync
7	TxIN9	G2	28	TxIN25	Vsync
11	TxIN12	G3	30	TxIN26	DE
12	TxIN13	G4	31	TxCLKIN	Clock

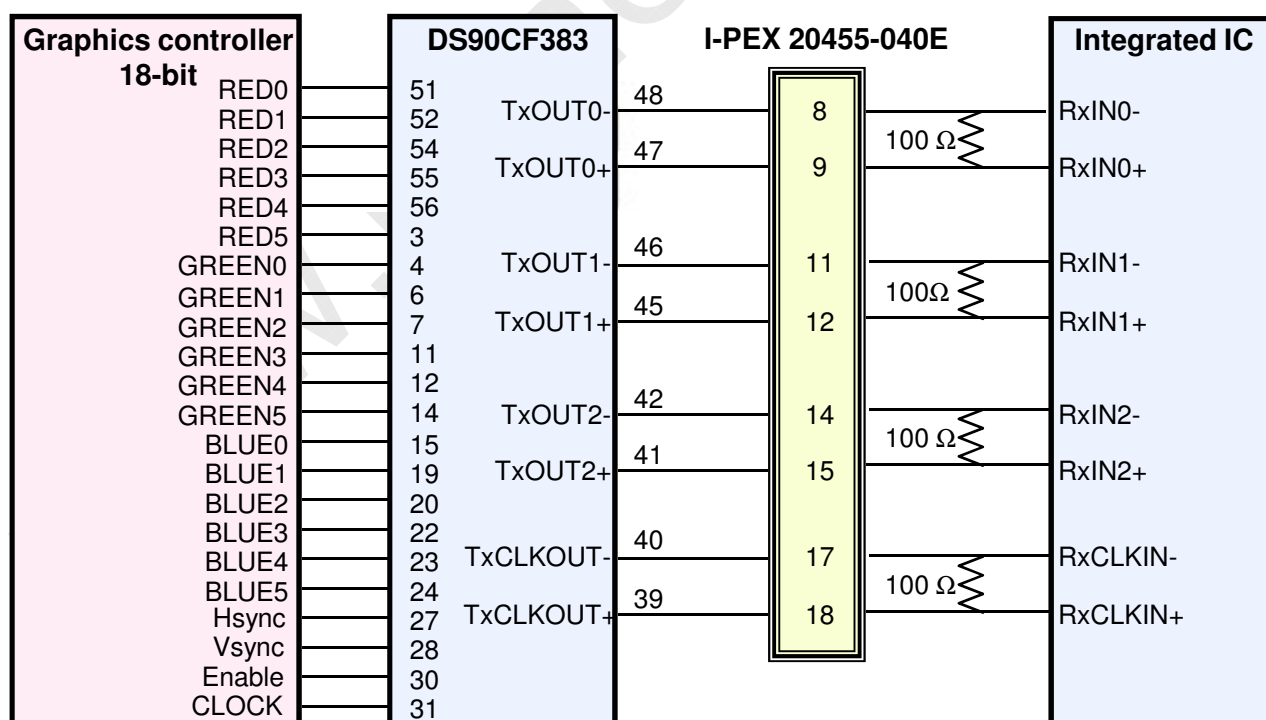
**LVDS INTERFACE**

Note : The LCD Module uses a 100ohm resistor between positive and negative lines of each receiver input.

Samsung Secret

Approval

## 5.3 Timing Diagrams of LVDS For Transmission

LVDS Receiver : Integrated T-CON

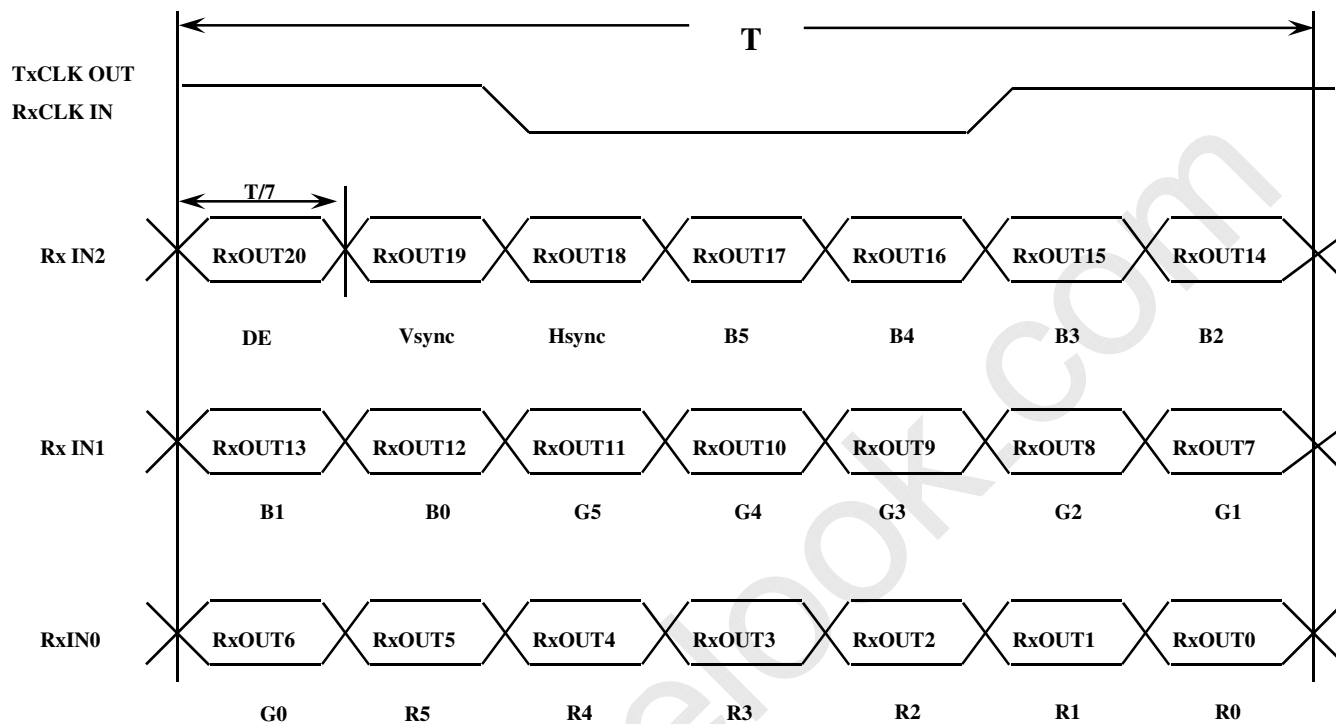

Samsung Secret

Doc.No.

LTN156AT17-W

Rev.No

04-A00-G-110621

Page

18 / 27

Approval

### 5.4 Input Signals, Basic Display Colors and Gray Scale of Each Color

Color	Display	Data Signal																Gray Scale Level	
		Red					Green					Blue							
		R0	R1	R2	R3	R4	R5	G0	G1	G2	G3	G4	G5	B0	B1	B2	B3		45
Basic Colors	Black	0	0	0	0	0	0	0	0	0	0	0	0	0	0	0	0	0	-
	Blue	0	0	0	0	0	0	0	0	0	0	0	0	1	1	1	1	1	-
	Green	0	0	0	0	0	0	1	1	1	1	1	1	0	0	0	0	0	-
	Cyan	0	0	0	0	0	0	1	1	1	1	1	1	1	1	1	1	1	-
	Red	1	1	1	1	1	1	0	0	0	0	0	0	0	0	0	0	0	-
	Magenta	1	1	1	1	1	1	0	0	0	0	0	0	1	1	1	1	1	-
	Yellow	1	1	1	1	1	1	1	1	1	1	1	1	0	0	0	0	0	-
	White	1	1	1	1	1	1	1	1	1	1	1	1	1	1	1	1	1	-
Gray Scale Of Red	Black	0	0	0	0	0	0	0	0	0	0	0	0	0	0	0	0	0	R0
	Dark	1	0	0	0	0	0	0	0	0	0	0	0	0	0	0	0	0	R1
	↑	0	1	0	0	0	0	0	0	0	0	0	0	0	0	0	0	0	R2
	:	:	:	:	:	:	:	:	:	:	:	:	:	:	:	:	:	:	R3-R60
	:	:	:	:	:	:	:	:	:	:	:	:	:	:	:	:	:	:	
	↓	1	0	1	1	1	1	0	0	0	0	0	0	0	0	0	0	0	R61
	Light	0	1	1	1	1	1	0	0	0	0	0	0	0	0	0	0	0	R62
	Red	1	1	1	1	1	1	0	0	0	0	0	0	0	0	0	0	0	R63
Gray Scale Of Green	Black	0	0	0	0	0	0	0	0	0	0	0	0	0	0	0	0	0	G0
	Dark	0	0	0	0	0	0	1	0	0	0	0	0	0	0	0	0	0	G1
	↑	0	0	0	0	0	0	0	1	0	0	0	0	0	0	0	0	0	G2
	:	:	:	:	:	:	:	:	:	:	:	:	:	:	:	:	:	:	G3-G60
	:	:	:	:	:	:	:	:	:	:	:	:	:	:	:	:	:	:	
	↓	0	0	0	0	0	0	1	0	1	1	1	1	0	0	0	0	0	G61
	Light	0	0	0	0	0	0	0	1	1	1	1	1	0	0	0	0	0	G62
	Green	0	0	0	0	0	0	1	1	1	1	1	1	0	0	0	0	0	G63
Gray Scale Of Blue	Black	0	0	0	0	0	0	0	0	0	0	0	0	0	0	0	0	0	B0
	Dark	0	0	0	0	0	0	0	0	0	0	0	1	0	0	0	0	0	B1
	↑	0	0	0	0	0	0	0	0	0	0	0	0	1	0	0	0	0	B2
	:	:	:	:	:	:	:	:	:	:	:	:	:	:	:	:	:	:	B3-B60
	:	:	:	:	:	:	:	:	:	:	:	:	:	:	:	:	:	:	
	↓	0	0	0	0	0	0	0	0	0	0	0	0	1	0	1	1	1	B61
	Light	0	0	0	0	0	0	0	0	0	0	0	0	0	1	1	1	1	B62
	Blue	0	0	0	0	0	0	0	0	0	0	0	0	1	1	1	1	1	B63

Note 1) Definition of gray :

Rn: Red gray, Gn: Green gray, Bn: Blue gray (n=gray level)

Note 2) Input signal: 0 =Low level voltage, 1=High level voltage

**Samsung Secret**

<b>Doc.No.</b>	LTN156AT17-W	<b>Rev.No</b>	04-A00-G-110621	<b>Page</b>	19 / 27
----------------	--------------	---------------	-----------------	-------------	---------

Approval

## 5.5 Pixel Format in the display

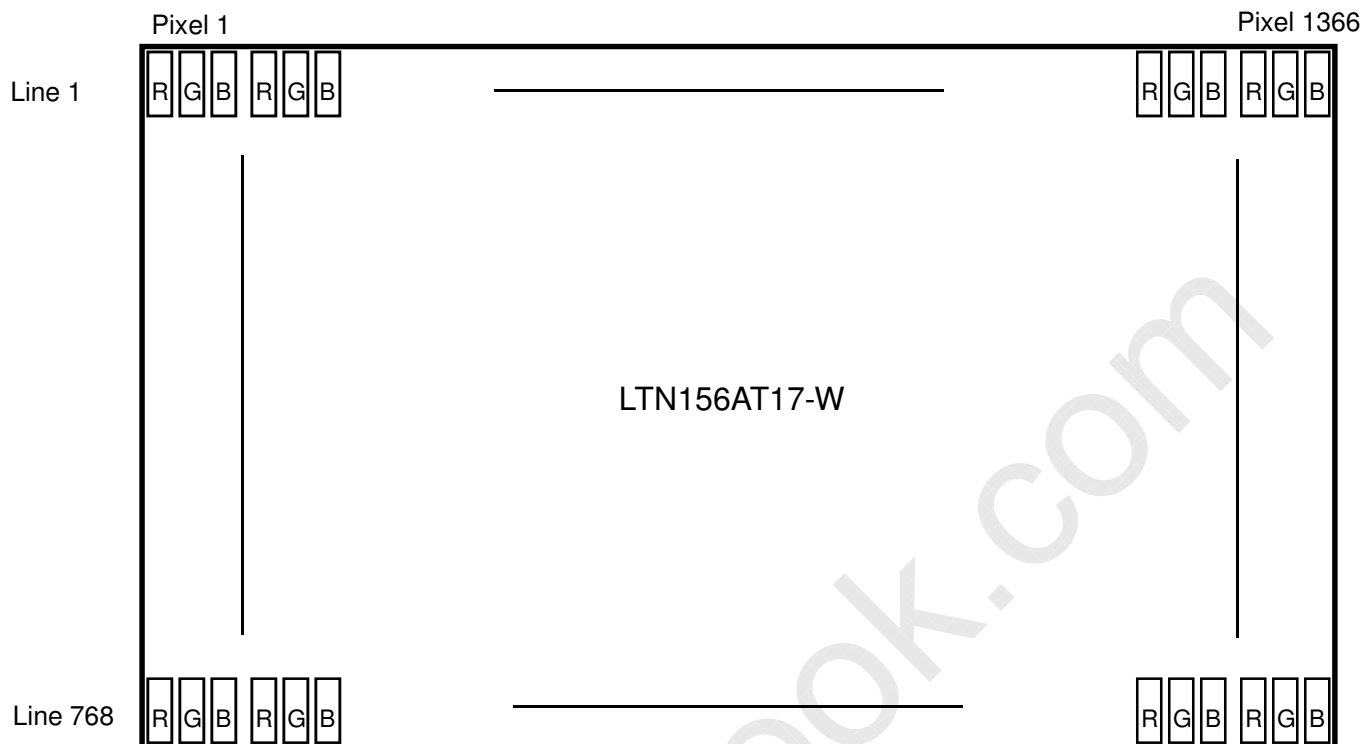

Samsung Secret

Doc.No.

LTN156AT17-W

Rev.No

04-A00-G-110621

Page

20 / 27

Approval

## 6. INTERFACE TIMING

### 6.1 Timing Parameters

Signal	Item	Symbol	Min.	Typ.	Max.	Unit	Note
Frame Frequency	Cycle	TV	-	790	-	Lines	-
Vertical Active Display Term	Display Period	TVD	-	768	-	Lines	-
One Line Scanning Time	Cycle	TH	-	1586	-	Clocks	-
Horizontal Active Display Term	Display Period	THD	-	1366	-	Clocks	-

### 6.2 Timing diagrams of interface signal

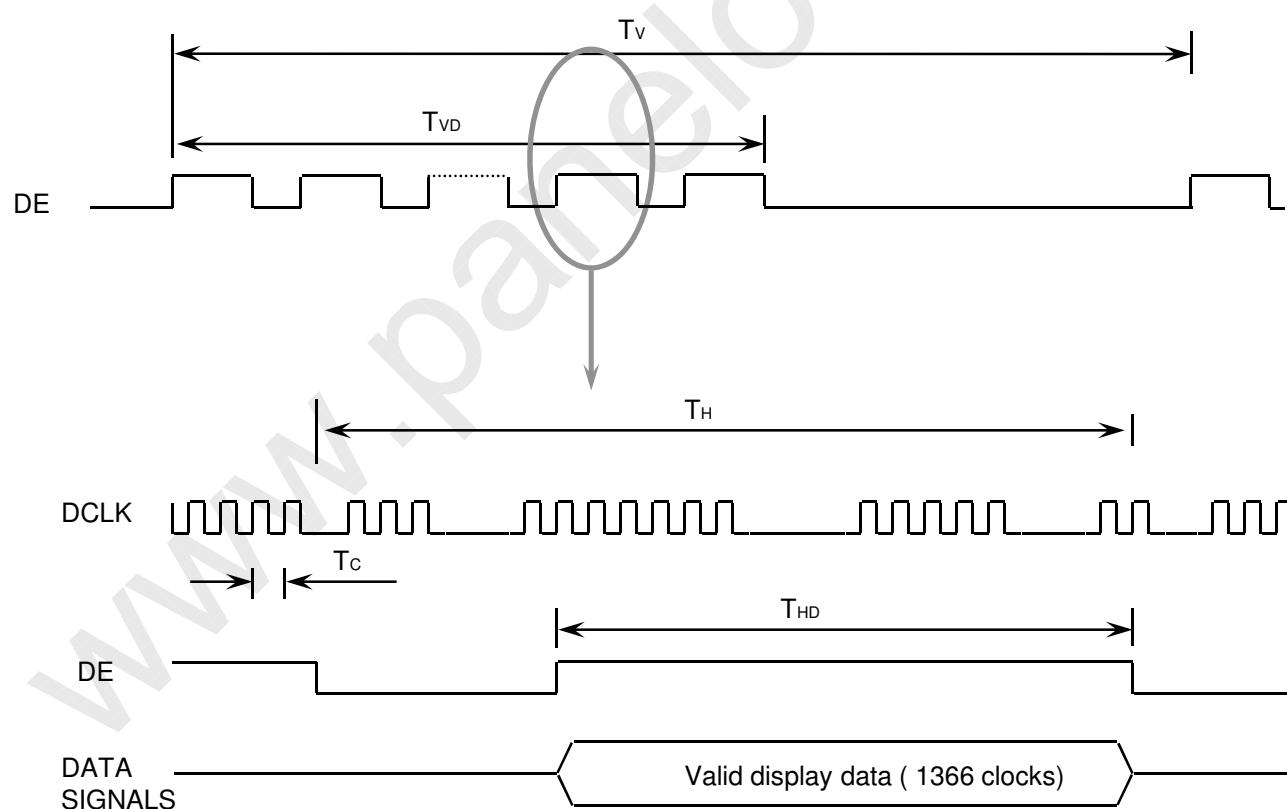

**Samsung Secret**

**Doc.No.**

LTN156AT17-W

**Rev.No**

04-A00-G-110621

**Page**

21 / 27

## 6.3 Power ON/OFF Sequence

Approval

: To prevent a latch-up or DC operation of the LCD module, the power on/off sequence should be as the diagram below.

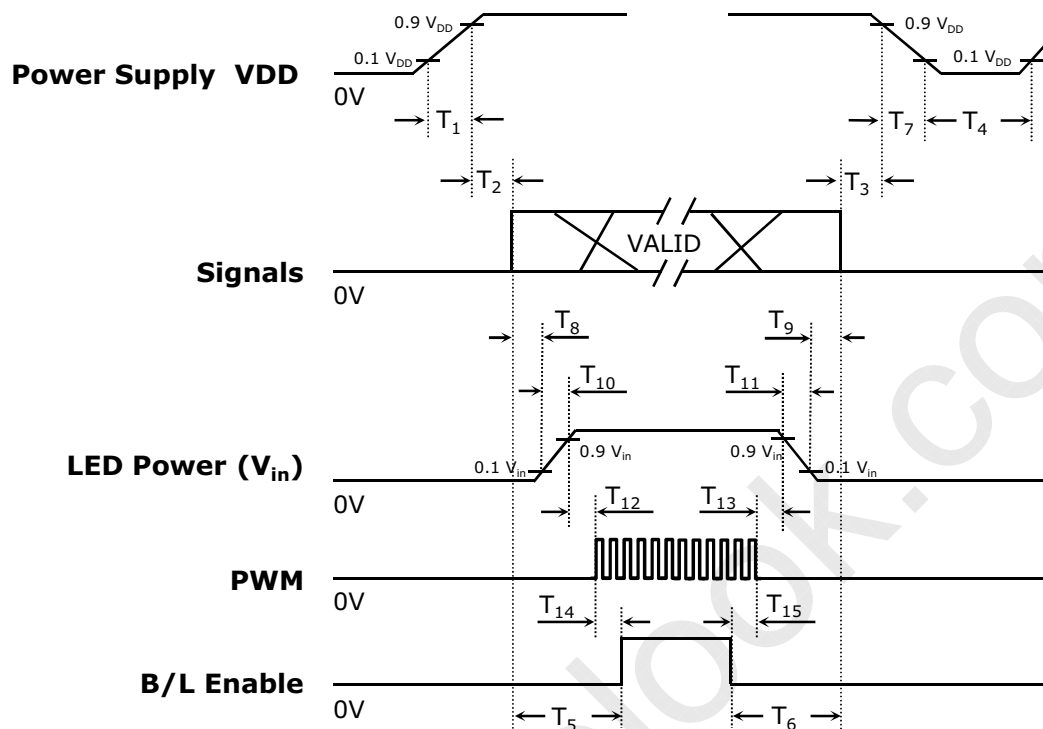

Timing (ms)	Remarks
$0.5 < T_1 \leq 10$	V <sub>DD</sub> rising time from 10% to 90%
$0 < T_2 \leq 50$	Delay from V <sub>DD</sub> to valid data at power ON
$0 < T_3 \leq 50$	Delay from valid data OFF to V <sub>DD</sub> OFF at power Off
$500 \leq T_4$	V <sub>DD</sub> OFF time for Windows restart
$200 \leq T_5$	Delay from valid data to B/L enable at power ON
$200 \leq T_6$	Delay from valid data off to B/L disable at power Off
$0 < T_7 \leq 10$	V <sub>DD</sub> falling time from 90% to 10%
$10 < T_8$	Delay from valid data on to LED driver V <sub>in</sub> rising time 10%
$10 < T_9$	Delay from LED driver V <sub>in</sub> falling time 10% to valid data Off
$0.5 < T_{10} \leq 10$	LED V <sub>in</sub> rising time from 10% to 90%
$0.5 < T_{11} \leq 10$	LED V <sub>in</sub> falling time from 90% to 10%
$10 < T_{12}$	Delay from LED driver V <sub>in</sub> rising time 90% to PWM ON
$10 < T_{13}$	Delay from PWM Off to LED driver V <sub>in</sub> falling time 10%
$10 < T_{14}$	Delay from PWM ON to B/L Enable ON
$10 < T_{15}$	Delay from B/L Enable Off to PWM Off

Note : Backlight may flash if interface signal remains floating state at invalid period.

Samsung Secret

Doc.No.	LTN156AT17-W	Rev.No	04-A00-G-110621	Page	22 / 27
---------	--------------	--------	-----------------	------	---------

# 7. MECHANICAL OUTLINE DIMENSION

Approval

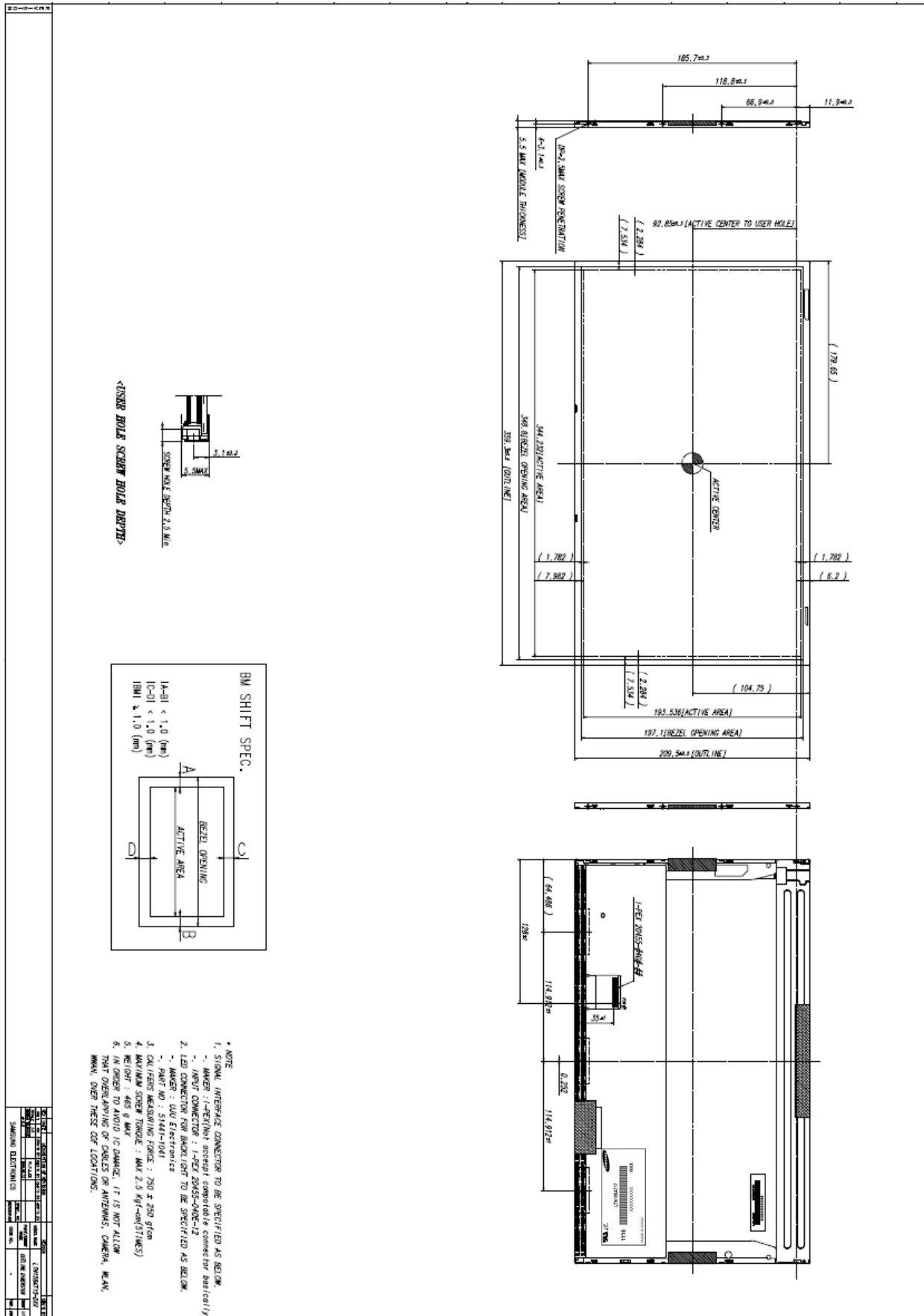

**Samsung Secret**

## 8. PACKING

Approval

### 1. CARTON(Internal Package)

#### (1) Packing Form

Corrugated Cardboard box and Corrupad form as shock absorber

#### (2) Packing Method

CUSHION BOTTOM

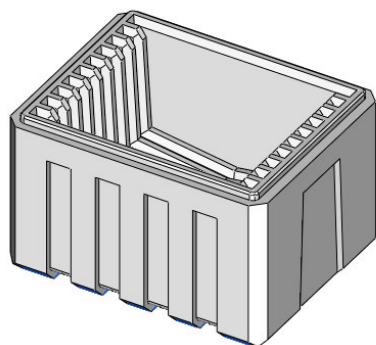

PANEL : 2EA/SLIT

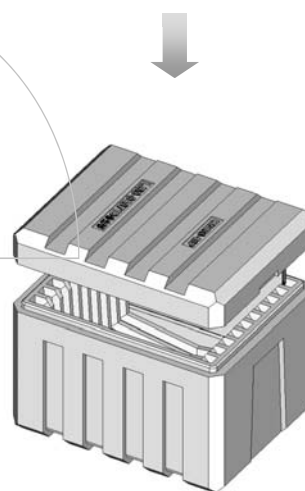
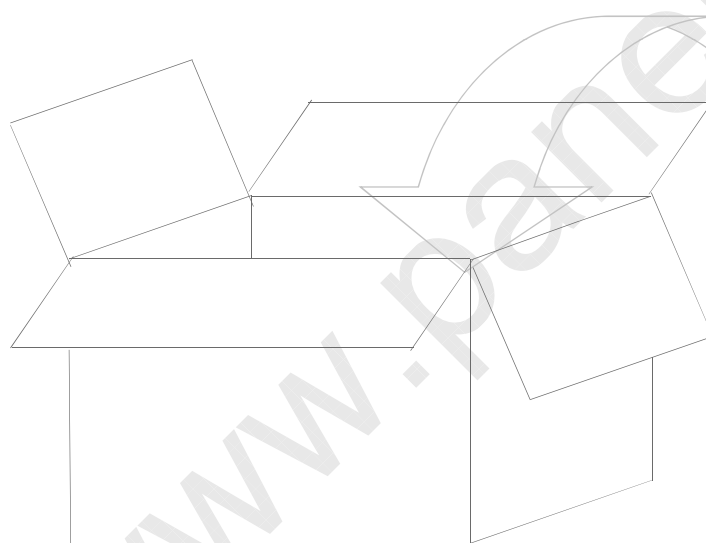
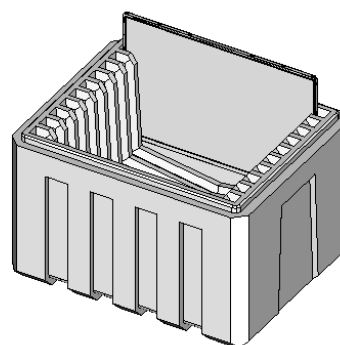

CUSHION TOP, BOTTOM

Note (1) Total : Approx. 12400 g

(2) Acceptance number of piling : 20 sets

(3) Carton size : 359(W) X 463(D) X 333(H)

(4) MAX accumulation quantity : 5 cartons

**Samsung Secret**

Doc.No.

LTN156AT17-W

Rev.No

04-A00-G-110621

Page

24 / 27



Approval

No	Part name	Quantity
1	Static electric protective sack	20
2	Packing case (Inner box) included shock absorber	1 set
3	Pictorial marking	2 pcs
4	Carton	1 set

### 9. MARKINGS & OTHERS

A nameplate bearing followed by is affixed to a shipped product at the specified location on each product.

(1) Parts number : LTN156AT17

(2) Revision code : 3 letters

(3) Lot number : X X X X XX XX XX WXX

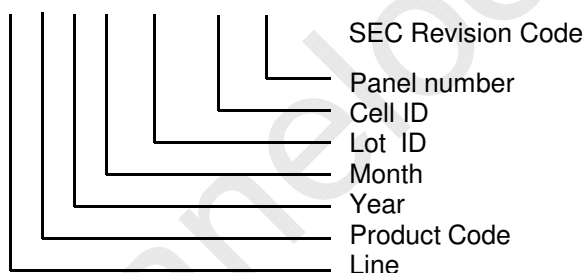

(4) Nameplate Indication

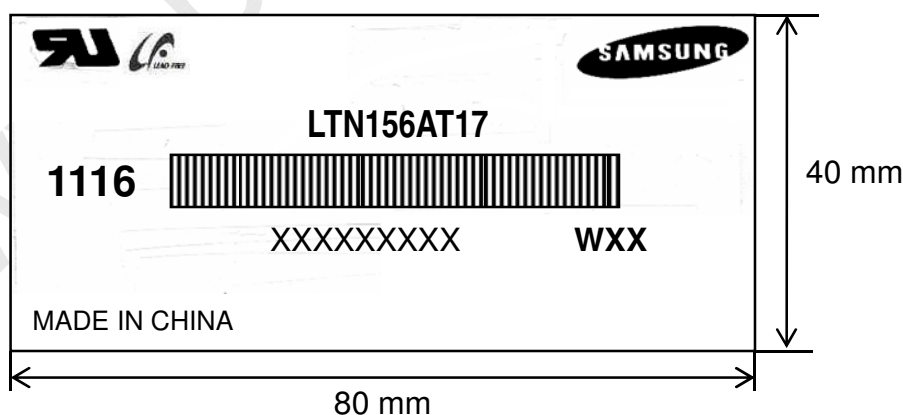

Parts name : LTN156AT17  
 Lot number : XXXXXXXXXX  
 Inspected work week : 1116(2011 year 16th week)  
 Product Revision Code : WXX

**Samsung Secret**

## 10. GENERAL PRECAUTIONS

Approval

### 1. Handling

- (a) When the module is assembled, It should be attached to the system firmly using every mounting holes. Be careful not to twist and bend the modules.
- (b) Refrain from strong mechanical shock and / or any force to the module. In addition to damage, this may cause improper operation or damage to the module.
- (c) Note that polarizers are very fragile and could be easily damaged. Do not press or scratch the surface harder than a HB pencil lead.
- (d) Wipe off water droplets or oil immediately. If you leave the droplets for a long time, Staining and discoloration may occur.
- (e) If the surface of the polarizer is dirty, clean it using some absorbent cotton or soft cloth.
- (f) The desirable cleaners are water, IPA (Isoprophyl Alcohol) or Hexane. Do not use Ketone type materials(ex. Acetone), Ethyl alcohol, Toluene, Ethyl acid or Methyl chloride. It might permanent damage to the polarizer due to chemical reaction.
- (g) If the liquid crystal material leaks from the panel, it should be kept away from the eyes or mouth. In case of contact with hands, legs or clothes, it must be washed away thoroughly with soap.
- (h) Protect the module from static, it may cause damage to the C-MOS Gate Array IC.
- (i) Use fingerstalls with soft gloves in order to keep display clean during the incoming inspection and assembly process.
- (j) Do not disassemble the module.
- (k) Do not pull or fold the lamp wire.
- (l) Do not adjust the variable resistor which is located on the back side.
- (m) Protection film for polarizer on the module shall be slowly peeled off just before use so that the electrostatic charge can be minimized.
- (n) Pins of I/F connector shall not be touched directly with bare hands.

**Samsung Secret**

<b>Doc.No.</b>	LTN156AT17-W	<b>Rev.No</b>	04-A00-G-110621	<b>Page</b>	26 / 27
----------------	--------------	---------------	-----------------	-------------	---------

Approval

## 2. STORAGE

- (a) Do not leave the module in high temperature, and high humidity for a long time. It is highly recommended to store the module with temperature from 0 to 35 °C and relative humidity of less than 70%.
- (b) Do not store the TFT-LCD module in direct sunlight.
- (c) The module shall be stored in a dark place. It is prohibited to apply sunlight or fluorescent light during the store.

## 3. OPERATION

- (a) Do not connect,disconnect the module in the " Power On" condition.
- (b) Power supply should always be turned on/off by following item 6.3 " Power on/off sequence ".
- (c) Module has high frequency circuits. Sufficient suppression to the electromagnetic interference shall be done by system manufacturers. Grounding and shielding methods may be important to minimize the interference.
- (d) The standard limited warranty is only applicable when the module is used for general notebook applications. If used for purposes other than as specified, SEC is not to be held reliable for the defective operations. It is strongly recommended to contact SEC to find out fitness for a particular purpose.

## 4. OTHERS

- (a) Ultra-violet ray filter is necessary for outdoor operation.
- (b) Avoid condensation of water. It may result in improper operation or disconnection of electrode.
- (c) Do not exceed the absolute maximum rating value. ( the supply voltage variation, input voltage variation, variation in part contents and environmental temperature, so on) Otherwise the module may be damaged.
- (d) If the module displays the same pattern continuously for a long period of time,it can be the situation when the image "sticks" to the screen.
- (e) This module has its circuitry PCB's on the rear side and should be handled carefully in order not to be stressed.

Samsung Secret

<b>Doc.No.</b>	LTN156AT17-W	<b>Rev.No</b>	04-A00-G-110621	<b>Page</b>	27 / 27
----------------	--------------	---------------	-----------------	-------------	---------