



TO : General

DATE : Jan. 25 , 2013

SAMSUNG TFT-LCD
MODEL NO. : LTN156AT19-0

NOTE : Extension code [- 0xx]
→ LTN156AT19-0xx
Surface type [A/G]

Any modification of Spec is not allowed without SEC's permission

Application engineering part, Mobile Division
Samsung Electronics Co., Ltd.

Samsung Secret

CONTENTS

Revision History	----- (3)
General Description	----- (4)
1. Absolute Maximum Ratings	----- (5)
1.1 Absolute Ratings of environment	
1.2 Electrical Absolute Ratings	
2. Optical Characteristics	----- (7)
3. Electrical Characteristics	----- (10)
3.1 TFT LCD Module	
3.2 Backlight Unit	
3.3 LED Driver	
4. Block Diagram	----- (13)
4.1 TFT LCD Module	
4.2 LED Placement Structure	
5. Input Terminal Pin Assignment	----- (14)
5.1 Input Signal & Power	
5.2 LVDS Interface	
5.3 Timing Diagrams of LVDS For Transmitting	
5.4 Pixel format	
6. Interface Timing	
6.1 Timing Parameters	----- (19)
6.2 Timing Diagrams of interface Signal	
6.3 Power ON/OFF Sequence	
7. Outline Dimension	----- (222)
8. Packing	----- (24)
9. Markings & Others	----- (25)
10. General Precautions	----- (27)
11. EDID	----- (29)

Samsung Secret

REVISION HISTORY

Product Information

Date	Revision No.	Page	Summary
Jan, 25. 2013	A00	All	The approval specification of 15.6" SMS HD was issued first.

CODE REVISION HISTORY

Date	Model.	Revision No.	Summary
June, 15. 2011	LTN156AT19	001	Basic model

Samsung Secret

Doc.No.	LTN156AT19-0	Rev.No	04-A00-G-130125	Page	3 / 31
----------------	--------------	---------------	-----------------	-------------	--------

GENERAL DESCRIPTION

DESCRIPTION

LTN156AT19 is a color active matrix TFT (Thin Film Transistor) liquid crystal display (LCD) that uses amorphous silicon TFT as switching devices.

This model is composed of a TFT LCD panel, a driver circuit and a backlight unit.

The resolution of a 15.6" contains 1366 x 768 pixels and can display up to 262,144 colors. 6 O'clock direction is the optimum viewing angle.

FEATURES

- High contrast ratio
- HD(1366 x 768 pixels) resolution
- Fast Response
- LED Back Light with embedded LED Driver
- DE (Data enable) only mode
- 3.3V LVDS Interface
- Onboard EEDID chip

APPLICATIONS

- Notebook PC
- If the usage of this product is not for PC application, but for others, please contact SEC

GENERAL INFORMATION

Item	Specification	Unit	Note
Display area	344.232 (H) x 193.536 (V) (15.6"diagonal)	mm	
Driver element	a-Si TFT active matrix		
Display colors	262,144		
Number of pixel	1366 * 768	pixel	
Pixel arrangement	RGB vertical stripe		
Pixel pitch	0.252 (H) x 0.252 (V) (TYP.)	mm	
Display Mode	Normally white		
Surface treatment	Haze 25%, Hardness 2H		A/G

Samsung Secret

Mechanical Information

Item		Min.	Typ.	Max.	Unit	Note
Module size	Horizontal (H)	358.8	359.3	359.8	mm	
	Vertical (V)	209.0	209.5	210.0	mm	
	Depth (D)	-	-	4.0	mm	
Weight		-	-	430	g	

Note (1) Measurement condition of outline dimension

- . Equipment : Bernier Calipers
- . Push Force : 500g · f (minimum)

1. ABSOLUTE MAXIMUM RATINGS

1.1 ENVIRONMENTAL ABSOLUTE RATINGS

Item	Symbol	Min.	Max.	Unit	Note
Storage temperate	TSTG	-20	60	°C	(1)
Operating temperate (Temperature of glass surface)	TOPR	0	50	°C	(1)
Shock (non-operating)	Snop	-	240	G	(2),(4)
Vibration (non-operating)	Vnop	-	2.41	G	(3),(4)

Note (1) Temperature and relative humidity range are shown in the figure below.

95 % RH Max. ($40\text{ °C} \geq T_a$)

Maximum wet - bulb temperature at 39 °C or less. ($T_a > 40\text{ °C}$) No condensation

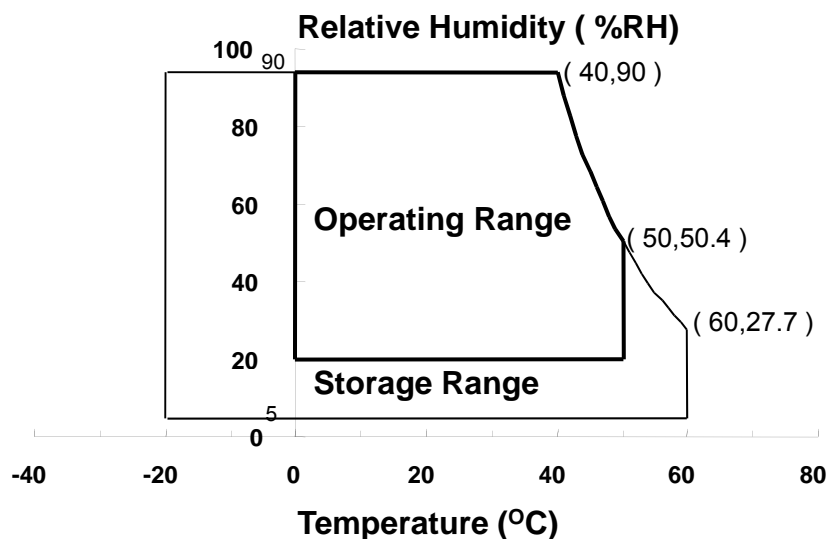

(2) 2ms, half sine wave, one time for $\pm X$, $\pm Y$, $\pm Z$.

(3) 5 - 500 Hz, random vibration, 30min for X, Y, Z.

(4) At testing Vibration and Shock, the fixture in holding the Module to be tested have to be hard and rigid enough so that the Module would not be twisted or bent by the fixture.

Samsung Secret

1.2 ELECTRICAL ABSOLUTE RATINGS

(1) TFT LCD MODULE

$V_{DD} = 3.3V, V_{SS} = GND = 0V$

Item	Symbol	Min.	Max.	Unit	Note
Power Supply Voltage	V_{DD}	$V_{DD} - 0.3$	$V_{DD} + 0.3$	V	(1)
Logic Input Voltage	V_{IN}	$V_{DD} - 0.3$	$V_{DD} + 0.3$	V	(1)

Note (1) Within T_a ($25 \pm 2 \text{ }^\circ\text{C}$)

(2) BACK-LIGHT UNIT

$T_a = 25 \pm 2 \text{ }^\circ\text{C}$

Item	Symbol	Min.	Typ.	Max.	Unit	Note
LED Current	I_L	-	22	-	mA	(1)
LED Voltage	V_L	-	3.2	-	V	(1)

Note 1) Permanent damage to the device may occur if maximum values are exceeded
Functional operation should be restricted to the conditions described under normal operating conditions.

Samsung Secret

2. OPTICAL CHARACTERISTICS

The following items are measured under stable conditions. The optical characteristics should be measured in a dark room or equivalent state with the methods shown in Note (5).
Measuring equipment : TOPCON SR-3

* Ta = 25 ± 2 °C, V_{DD}=3.3V, fv= 60Hz, f_{DCLK} = 70.7MHz, IF = 100% duty

Item	Symbol	Condition	Min.	Typ.	Max	Unit	Note	
Contrast Ratio (5 Points)	CR	Normal Viewing Angle $\phi = 0$ $\theta = 0$	300	-	-	-	(1), (2), (5)	
Response Time at Ta (Rising + Falling)	T _{RT}		-	16	25	msec	(1), (3)	
Average Luminance of White (5 Points)	Y _{L,AVE}		200	220	-	cd/m ²	IF=100% duty (1), (4)	
Color Chromaticity (CIE)	Red		R _X	Typ- 0.03	0.570	Typ +0.03	-	(1), (5) SR-3
			R _Y		0.340			
	Green		G _X		0.330			
			G _Y		0.560			
	Blue		B _X		0.160			
			B _Y		0.135			
	White		W _X		0.313			
		W _Y	0.329					
Viewing Angle	Hor.	θ_L	CR ≥ 10 At center	40	45	-	Degrees	
		θ_H		40	45	-		
	Ver.	ϕ_H		15	15	-		
		ϕ_L		30	30-	-		
Color Gamut	CG	-	45	-	%			
13 Points White Variation	δ_L	-	-	2.0	-	(6)		

Samsung Secret

Note 1) Definition of Viewing Angle : Viewing angle range($10 \leq C/R$)

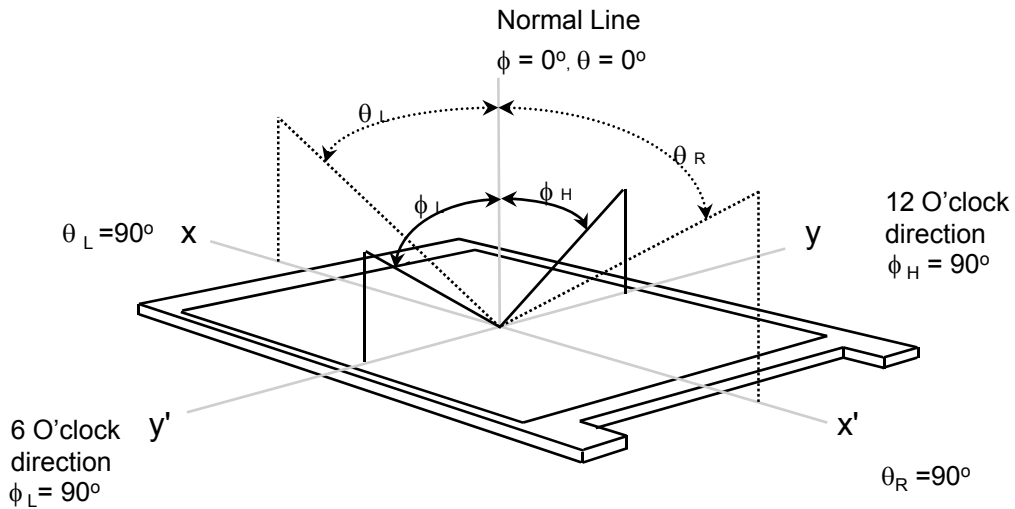

Note 2) Definition of Contrast Ratio (CR) : Ratio of gray max (Gmax) ,gray min (Gmin) at 5 points(4, 5, 7, 9, 10)

$$CR = \frac{CR(4) + CR(5) + CR(7) + CR(9) + CR(10)}{5}$$

Points : (4) , (5) , (7) , (9) , (10) at the figure of Note (6).

Note 3) Definition of Response time :

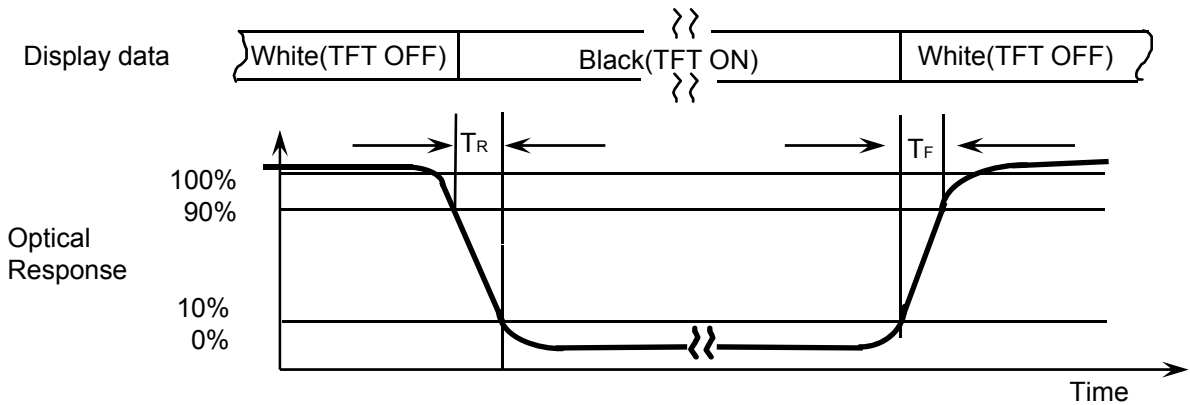

Note 4) Definition of Average Luminance of White : measure the luminance of white at 5 points.

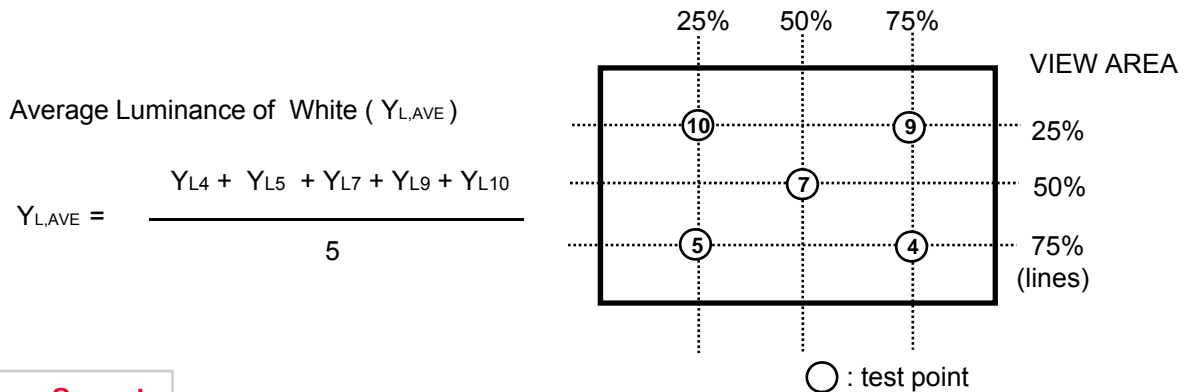

Samsung Secret

Note 5) After stabilizing and leaving the panel alone at a given temperature for 30 min , the measurement should be executed. Measurement should be executed in a stable, windless, and dark room. 30 min after lighting the backlight. This should be measured in the center of screen.

IF current : 22mA

Environment condition : $T_a = 25 \pm 2 \text{ }^\circ\text{C}$

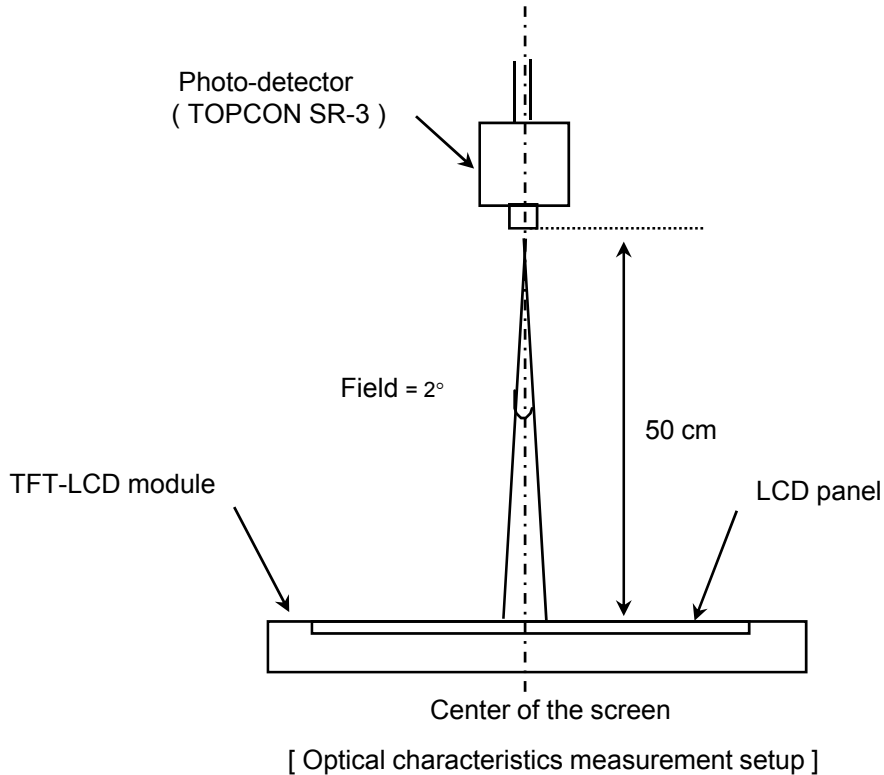

Note 6) Definition of 13 points white variation (δL), CR variation(C_{VER}) [① ~ ⑬]

$$\delta L = \frac{\text{Maximum luminance of 13 points}}{\text{Minimum luminance of 13 points}}$$

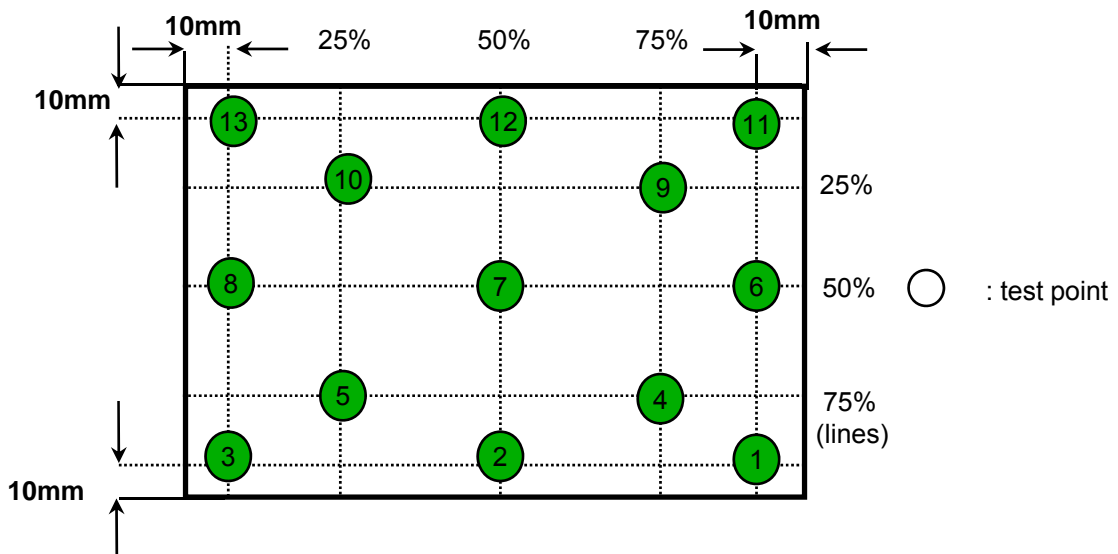

Samsung Secret

3. ELECTRICAL CHARACTERISTICS

3.1 TFT LCD MODULE

Ta= 25 ± 2°C

Item	Symbol	Min.	Typ.	Max.	Unit	Note	
Voltage of Power Supply	V _{DD}	3.0	3.3	3.6	V		
Differential Input Voltage for LVDS Receiver Threshold	High	V _{IH}	-	-	+100	mV	V _{CM} = +1.2V
	Low	V _{IL}	-100	-	-	mV	
Vsync Frequency	f _v	-	60	-	Hz		
Main Frequency	f _{DCLK}	66.14	70.7	83.88	MHz	-	
Rush Current	I _{RUSH}	-	-	1.5	A	(4)	
Current of Power Supply	White	IDD	-	230	-	mA	*a),b),c)
	Mosaic		-	230	-	mA	
	V.stripe		-	300	350	mA	

Note (1) Display data pins and timing signal pins should be connected.(GND = 0V)

(2) f_v = 60Hz, f_{DCLK} = 72.33MHz, V_{DD} = 3.3V , DC Current.

(3) Power dissipation pattern

*a) White Pattern

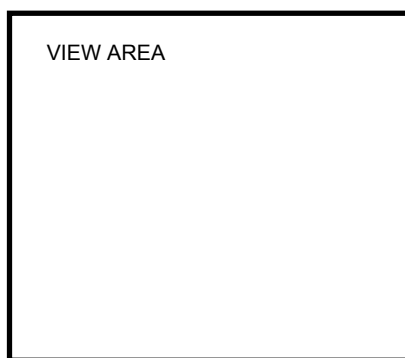

*b) Mosaic Pattern

Display Brightest Gray Level →

Display Darkest Gray Level →

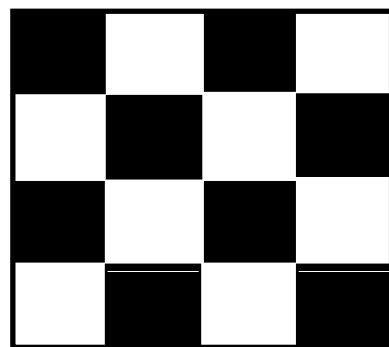

Samsung Secret

*c) 1dot Vertical stripe pattern

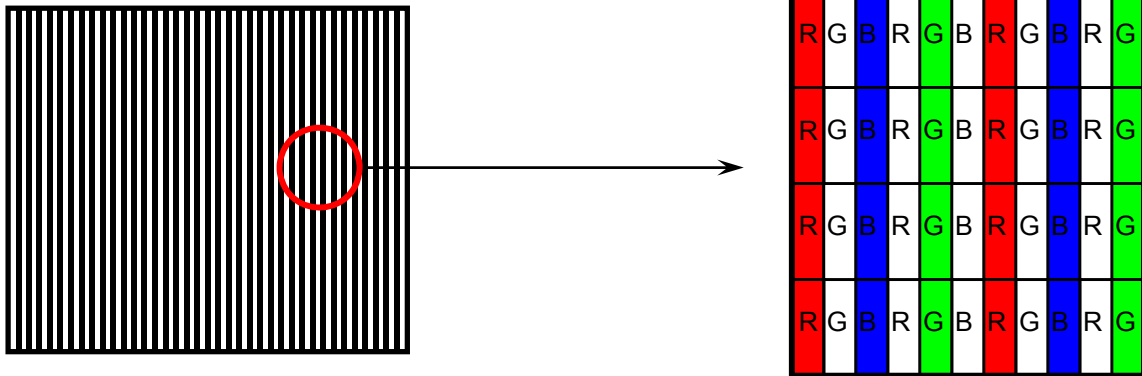

4) Rush current measurement condition

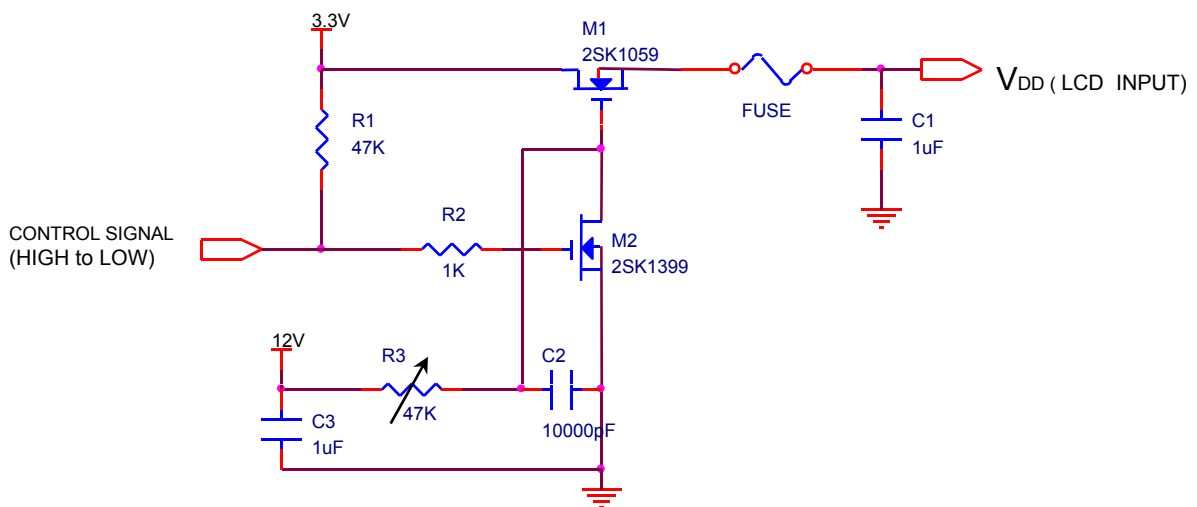

V_{DD} rising time is 470us

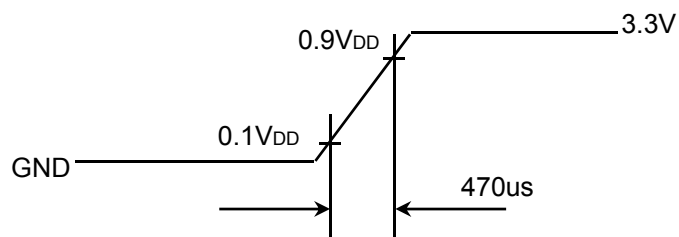

Samsung Secret

3.2 LED Driver

- On board LED Driver (Intersil)

Ta= 25 ± 2 °C

Item-	Symbol	Min.	Typ.	Max.	Unit	Note
Input Voltage	V _{in}	7	12	20	V	-
Input Current	I	-	270	-	mA	-
power consumption	P	-	0.9	1.0	W	@ 60nit
		-	3.3	3.5	W	@ Max
EN control level	ON	2.0	-	-	V	
	OFF	-	-	0.8	V	
PWM control level	ON	2.0	-	-	V	
	OFF	-	-	0.8	V	
PWM Control Duty Ratio	D	5	-	100	%	PWM freq : 200Hz~10KHz
		10	-	100		PWM freq : 1KHz~10KHz
External PWM Dimming Control Frequency (BLIM)	F _{BLIM}	0.2	1	10	kHz	
Operating Life Time	Hr	10,000	-	-	Hour	

Note (1) Life time (Hr) of LEDs can be defined as the time in which it continues to operate under the condition Ta= 25 ± 2 °C and IF = 22mA until one of the following event occurs.
When the brightness becomes 50% or lower than the original.

3.3 BACK-LIGHT UNIT

Ta= 25 ± 2 °C

Item	Symbol	Min.	Typ.	Max.	Unit	Note
LED Forward Current	IF	-	22	-	mA	
LED Forward Voltage	VF	3.0	3.2	3.4	V	
LED Array Voltage	VP	-	36	-	V	
BL consumption	P	-	-	3.3	W	@ MAX

Samsung Secret

4. BLOCK DIAGRAM

4.1 TFT LCD Module

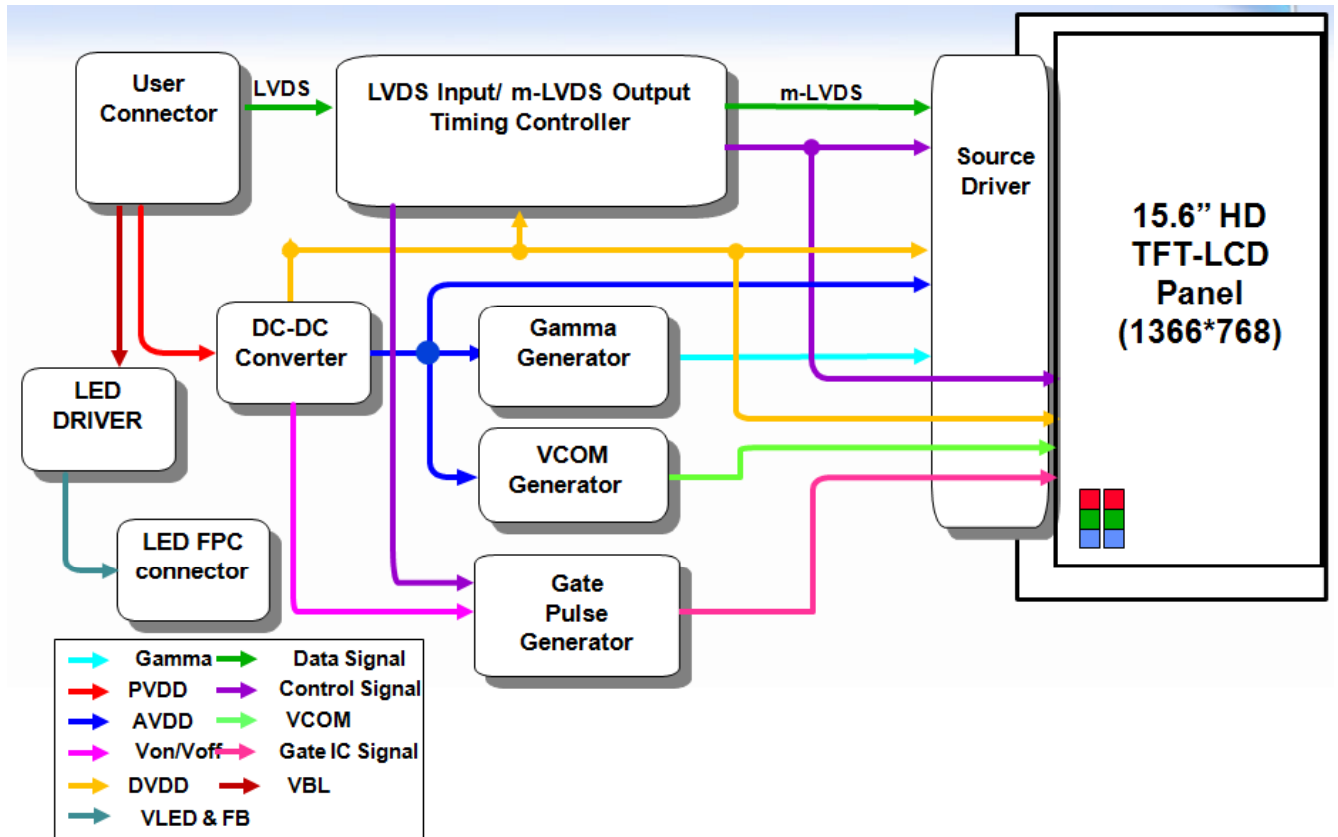

4.2 LED placement structure

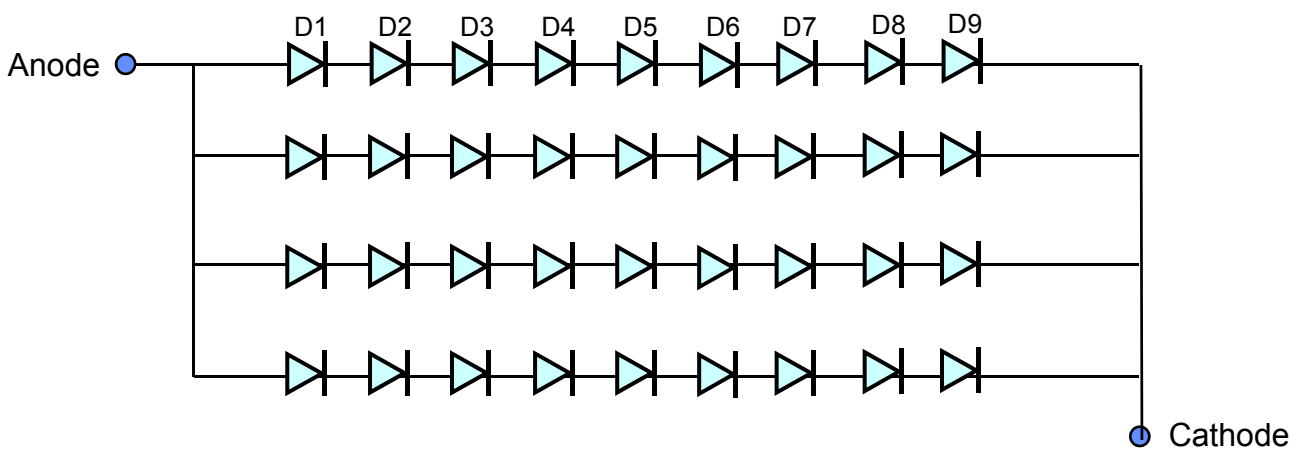

Samsung Secret

5. INPUT TERMINAL PIN ASSIGNMENT

5.1. Input Signal & Power (LVDS, Connector : I-PEX 20455-#40E-## or equivalent)

No.	Symbol	Function	Polarity	Remarks
1	NC	No Connection (Reserved for supplier)		
2	AVDD	Power Supply 3.3V (typical)		
3	AVDD	Power Supply 3.3V (typical)		
4	DVDD	DDC 3.3V power		
5	NC	No Connection		
6	SCL	DDC Clock		
7	SDA	DDC data		
8	RIN0-	-LVDS differential data input (R0-R5, G0)	Negative	
9	RIN0+	+LVDS differential data input (R0-R5, G0)	Positive	
10	GND	Ground		
11	RIN1-	-LVDS differential data input (G1-G5, B0-B1)	Negative	
12	RIN1+	+LVDS differential data input (G1-G5, B0-B1)	Positive	
13	GND	Ground		
14	RIN2-	-LVDS differential data input (B2-B5, HS, VS, DE)	Negative	
15	RIN2+	+LVDS differential data input (B2-B5, HS, VS, DE)	Positive	
16	GND	Ground		
17	CLK-	-LVDS differential clock input	Negative	
18	CLK+	+LVDS differential clock input	Positive	
19	GND	Ground		
20	NC	No connection		
21	NC	No connection		
22	GND	Ground		
23	NC	No connection		
24	NC	No connection		
25	GND	Ground		
26	NC	No connection		
27	NC	No connection		
28	GND	Ground		
29	NC	No Connect		
30	NC	No Connect		

Samsung Secret

No.	Symbol	Function	Polarity	Remarks
31	VSSLED	Ground – LED		
32	VSSLED	Ground – LED		
33	VSSLED	Ground – LED		
34	NC	No Connect		
35	PWM	System PWM Signal Input (+3.3V Swing)		
36	LED_EN	LED enable pin (+3.3V Input)		
37	NC	No Connect		
38	VDDLED	LED power		
39	VDDLED	LED power		
40	VDDLED	LED power		

Samsung Secret

5.2 LVDS Interface

5.2.1 LVDS DC Input

ITEM	SYMBOL	MIN.	TYP.	MAX.	UNIT	NOTE
LVDS Differential Voltage	VID	200	-	600	mV	
Input Common Mode Voltage	V _{CM}	0.4	1.2	1.7	V	

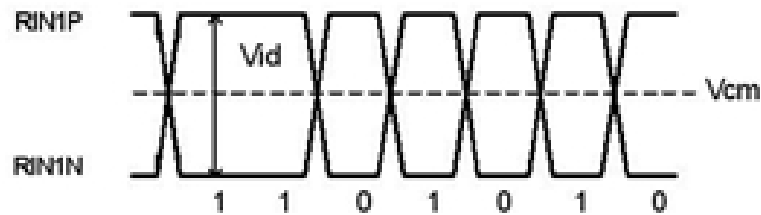

5.2.1 LVDS AC Input

ITEM	SYMBOL	MIN.	TYP.	MAX.	UNIT	NOTE
LVDS input Clock Frequency	F _{CLK_LVDS}	30	-	100	Mhz	
LVDS RX skew Right margin	100MHz	-	-	270	ps	(1), (2)
	50MHz	-	-	700	ps	(1), (2)
LVDS RX skew Left margin	100MHz	-270	-	-	ps	(1), (2)
	50MHz	-700	-	-	ps	(1), (2)
Maximum deviation of LVDS input clock during SSCG	F _{CLK_DEV}	-	-	± 3	%	(3)
Modulating frequency of LVDS input clock during SSCG	F _{CLK_MOD}	30	-	300	KHz	(3)

Note (1) : LVDS Receiver Skew (Strobe) Margin

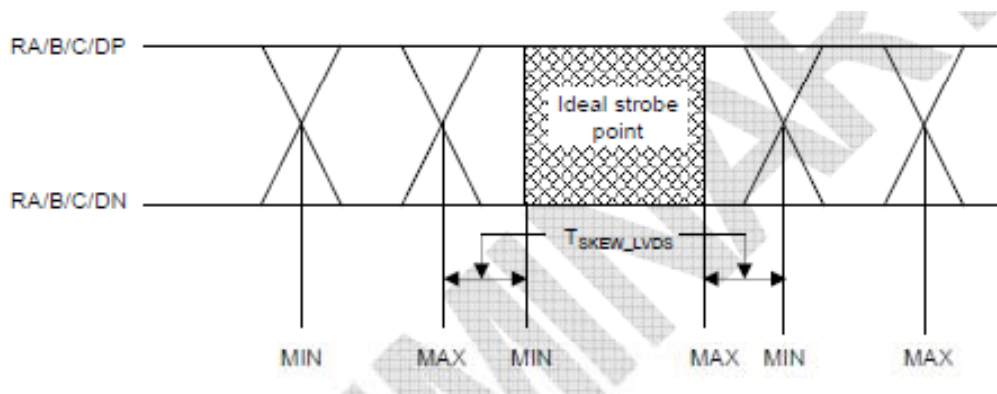

Samsung Secret

5.3 Timing Diagrams of LVDS For Transmission

LVDS Receiver : Integrated T-con

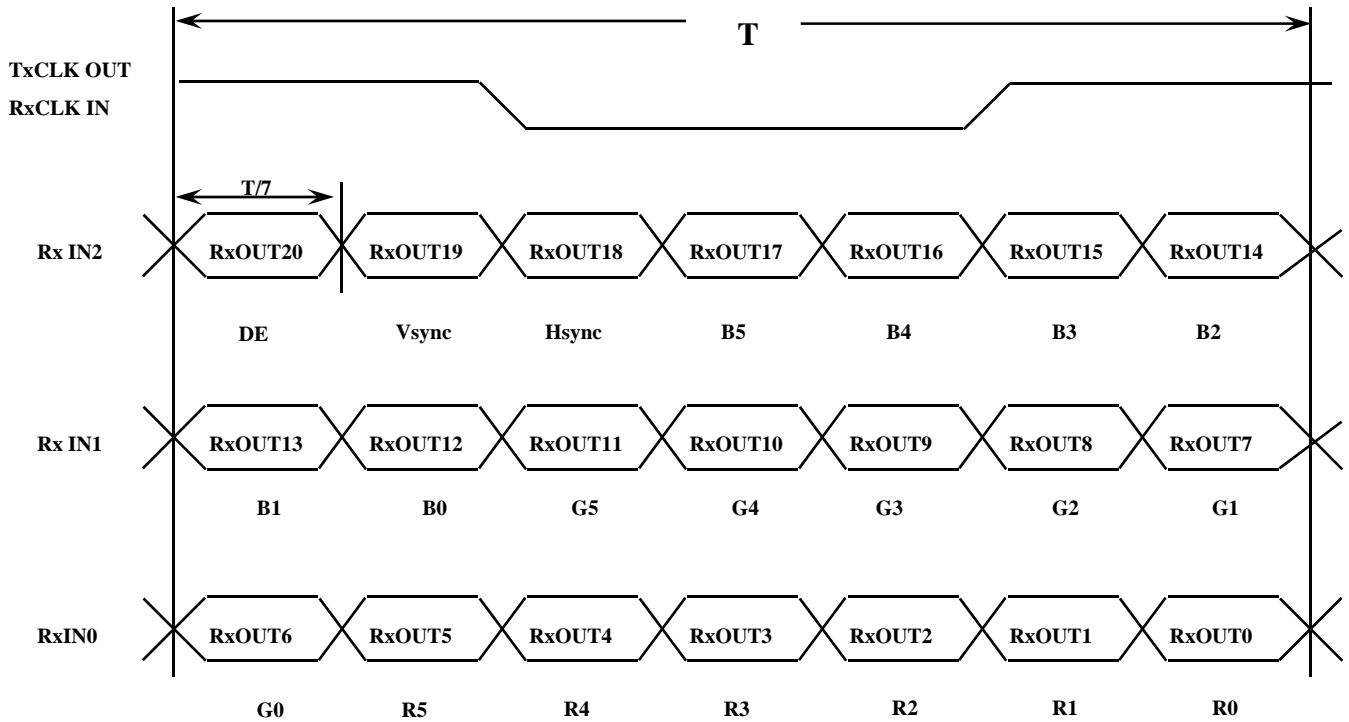

Samsung Secret

5.4 Pixel Format in the display

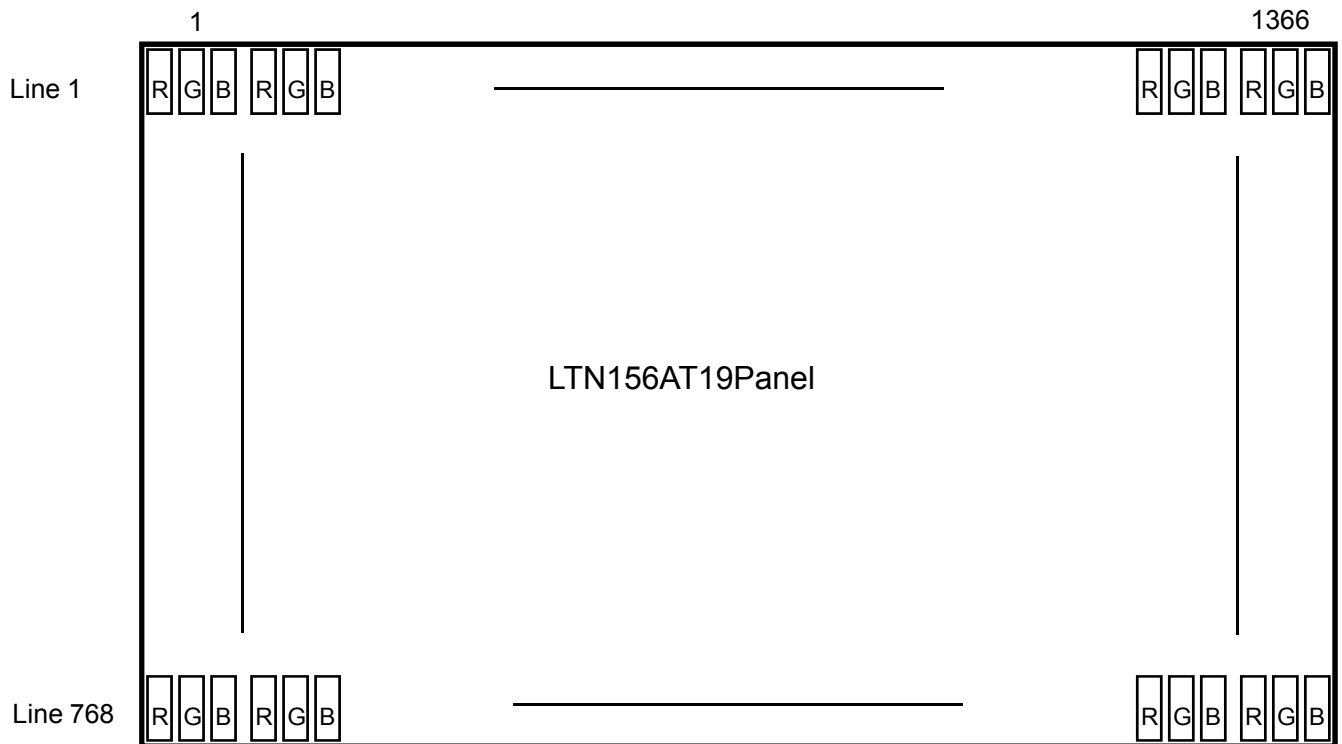

Samsung Secret

6. INTERFACE TIMING

6.1 Timing Parameters

Signal	Item	Symbol	Min.	Typ.	Max.	Unit	Note
Frame Frequency	Cycle	TV	773	790	810	Lines	
Vertical Active Display Term	Display Period	TVD	-	768	-	Lines	
One Line Scanning Time	Cycle	TH	1426	1526	1726	Clocks	
Horizontal Active Display Term	Display Period	THD	-	1366	-	Clocks	

6.2 Timing diagrams of interface signal

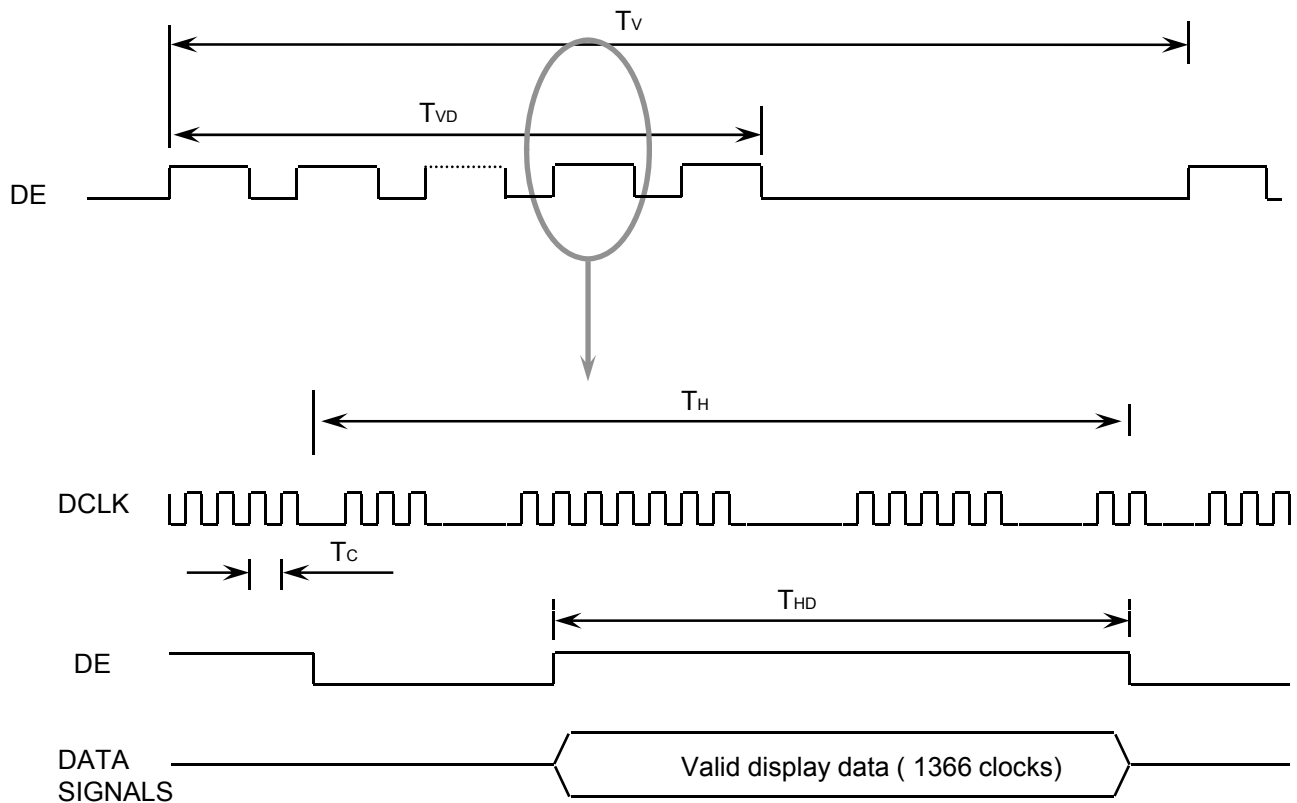

Samsung Secret

6.3 Power ON/OFF Sequence

: To prevent a latch-up or DC operation of the LCD module, the power on/off sequence should be as the diagram below.

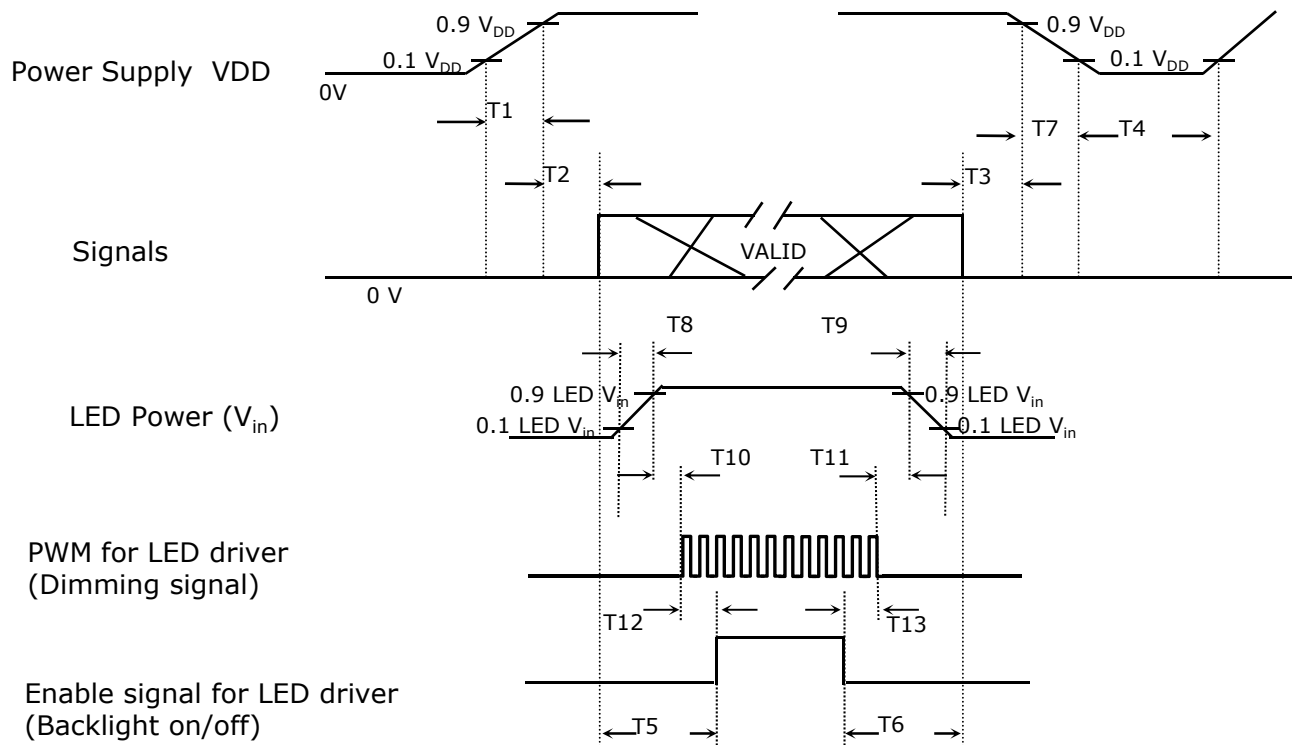

Power ON/OFF Sequence

Timing (ms)	Remarks
$0.5 < T1 \leq 10$	V _{DD} rising time from 10% to 90%
$0 < T2 \leq 50$	Delay from V _{DD} to valid data at power ON
$0 < T3 \leq 50$	Delay from valid data OFF to V _{DD} OFF at power Off
$500 \leq T4$	V _{DD} OFF time for Windows restart
$300 \leq T5$	Delay from valid data to B/L enable at power ON
$200 \leq T6$	Delay from valid data off to B/L disable at power Off
$0 < T7 \leq 10$	V _{DD} falling time from 90% to 10%
$0.5 < T8 \leq 10$	LED V _{in} rising time from 10% to 90%
$0.5 < T9 \leq 10$	LED V _{in} falling time from 90% to 10%
$0 \leq T10$	Delay from LED driver Vin rising time 90% to PWM ON
$0 \leq T11$	Delay from PWM Off to LED driver Vin falling time 10%, Must Keep rule
$0 \leq T12$	Delay from PWM ON to B/L Enable ON, Must Keep rule
$0 \leq T13$	Delay from B/L Enable Off to PWM Off

Power Sequence & Timing Parameters

Samsung Secret

6.3 Power ON/OFF Sequence

NOTE.

- (1) The supply voltage of the external system for the module input should be the same as the definition of V_{DD} .
- (2) Apply the lamp voltage within the LCD operation range. When the back-light turns on before the LCD operation or the LCD turns off before the back-light turns off, the display may momentarily become white.
- (3) In case of V_{DD} = off level, please keep the level of input signals on the low or keep a high impedance.
- (4) T4 should be measured after the module has been fully discharged between power off and on period.
- (5) Interface signal shall not be kept at high impedance when the power is on.

Samsung Secret