



SAMSUNG DISPLAY



Product Specification

- () Preliminary Specification
- () Approval Specification

Any modification of Spec is not allowed without SDC's permission.

CUSTOMER	Lenovo	MODEL NO.	LTN156AT29
DATE OF ISSUE	2012.09.11	EXTENSION CODE	-L01

Customer Approval & Feedback

Approved by	<i>James Lee</i> 12/09/11
Prepared by	Khan Kim 12/09/11
LCD Sales & Marketing Team Samsung Display Co., Ltd	

Table of Contents

REVISION HISTORY 3

1. GENERAL DESCRIPTION 4

2. ABSOLUTE MAXIMUM RATINGS 6

 2.1 ENVIRONMENTAL ABSOLUTE RATINGS 6

 2.2 ELECTRICAL ABSOLUTE RATINGS 7

 2.3 THE OTHERS 7

3. OPTICAL CHARACTERISTICS 8

4. BLOCK DIAGRAM 11

 4.1 TFT LCD MODULE 11

 4.2 THE STRUCTURE OF LED PLACEMENT 11

5. ELECTRICAL CHARACTERISTICS 12

 5.1 TFT LCD MODULE 12

 5.2 BACK LIGHT UNIT 14

 5.3 LED DRIVER 14

 5.4 LVDS INTERFACE 16

 5.5 INTERFACE TIMING 18

 5.6 INPUT COLOR DATA MAPPING 19

 5.7 POWER ON/OFF SEQUENCE 20

 5.8 INPUT TERMINAL PIN ASSIGNMENT 22

6. PIXEL FORMAT 23

7. OUTLINE DIMENSION 24

8. RELIABILITY TEST 26

9. PACKING 27

 9.1 CARTON 27

 9.2 MARKING 28

10. GENERAL PRECAUTIONS 30

 10.1 HANDLING 30

 10.2 STORAGE 31

 10.3 OPERATION 31

 10.4 OTHERS 32

11. EDID 33

12. APPENDIX 36

 12.1 SYSTEM DESIGN GUIDE 36

REVISION HISTORY

Date.	Rev.No.	Page	Revision Description
08/23/12	A00	ALL	. The approval specification was issued first.
09/04/12	A01	7	. Power supply voltage max was updated. . LVDS Input Voltage max was updated.
		12, 16	. Main frequency min was updated.
		18	. Timing parameters Scanning time min was updated.
09/11/12	A02	25	. 2D drawing was updated

FOR LENOV0 ONLY!

1. GENERAL DESCRIPTION

DESCRIPTION

The LTN156AT29-L01 uses a color active matrix TFT (Thin Film Transistor) liquid crystal display (LCD) that uses amorphous silicon TFTs as switching components. This model is composed of a TFT LCD panel, a driver circuit, and a backlight unit. This 15.6" model has a resolution of 1366 x 768 pixels and can display up to 262,144 colors.

FEATURES

- High contrast ratio
- HD(1366 x 768 pixels) resolution
- Low power consumption
- Fast Response
- LED back light with an embedded LED driver
- DE (Data enable) only mode
- 3.3V LVDS Interface
- Onboard EEDID chip

APPLICATIONS

Notebook PC
 If the intent to use this product is for other purpose, please contact Samsung Display.

GENERAL INFORMATION

Item	Specification	Unit	Note
Display area	344.232 (H) x 193.536 (V) (15.6" diagonal)	mm	
Driver Element	a-Si TFT active matrix		
Display colors	262,144 (6bit)		
Number of pixel	1366 * 768	Pixel	16:9
Pixel Arrangement	RGB vertical stripe		
Pixel pitch	0.252 (H) x 0.252 (V) (TYP.)	mm	
Display Mode	Normally white, TN mode		
Thickness of glass	0.5	mm	
Surface treatment	Haze 0, Hardness 3H		Glare
Environmental safe regulation	Pb Free, Halogen Free		

MECHANICAL INFORMATION

	Item	Min.	Typ.	Max.	Unit	Note
Module Size	Horizontal (H)	359.0	359.5	360.0	mm	w/o flange
	Vertical (V)	206.0	223.8	224.3	mm	with flange & PCB
		223.3	206.5	207.0	mm	w/o flange & PCB
	Depth (D)	-	-	3.2	mm	(1)
	Weight	-	-	380	g	

NOTE (1) Measuring method for thickness

Force to be applied for measurement (Body part) : when using the Micrometer.

Force to be applied for measurement (COF part) : The 50gf when using the height gauge.

For Lenovo Only

2. ABSOLUTE MAXIMUM RATINGS

2.1 ENVIRONMENTAL ABSOLTE RATINGS

Item	Symbol	Min.	Max.	Unit	Note
Storage temperate	TSTG	-20	60	°C	(1)
Operating temperature (Temperature of glass surface)	TOPR	0	50	°C	(1)
Shock (non-operating)	Snop	-	240	G	(2), (4)
Vibration (non-operating)	Vnop	-	2.41	G	(3), (4)

Note (1) The range of temperature and relative humidity are shown in the graph below 95% RH Max. .
 (39°C ≥ Ta) If the temperature is higher than 40 °C, the maximum temperature of wet-bulb shall be less than 39°C. No condensation

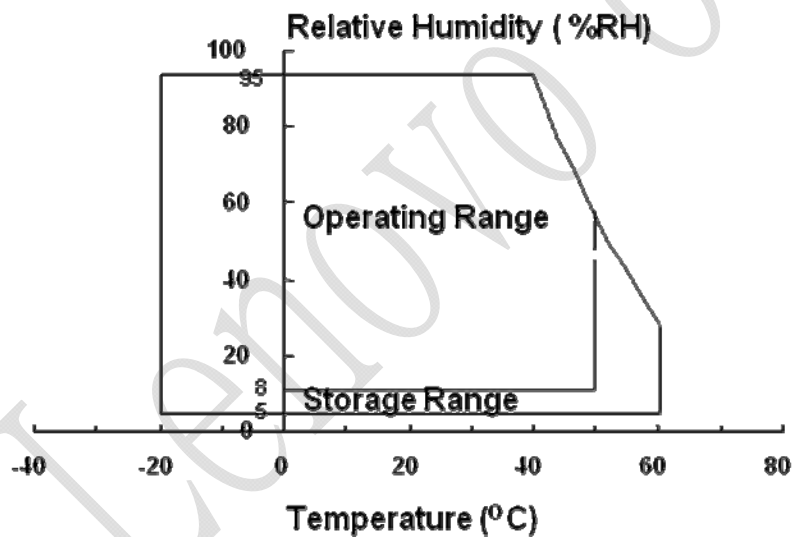

- (2) Vibrate ±X, ±Y, and ± Z axis in the shape of the half sine wave one time for 2ms .
- (3) Vibrate the X, Y, and Z randomly within a 5 - 500 Hz range for 30min.
- (4) When testing a vibration and a shock, the fixture, which holds the module to be tested shall be hard and rigid in order for the the module not to be twisted or bent by the fixture.

2.2 ELECTRICAL ABSOLUTE RATINGS

(1) TFT LCD MODULE

$V_{LCD_VCC} = 3.3V, V_{SS} = GND = 0V$

Item	Symbol	Min.	Max.	Unit	Note
Power Supply Voltage	V_{LCD_VCC}	$V_{SS} - 0.3$	4.0	V	(1),(2)
LVDS Input Voltage	V_{LVDS}	$V_{SS} - 0.3$	2.0		

Note (1) Within T_a ($25 \pm 2 \text{ }^\circ\text{C}$)

(2) Permanent damage to the device may occur if exceed maximum values

(2) BACKLIGHT UNIT

$V_{SS} = GND = 0V$

Item	Symbol	Min.	Max.	Unit	Note
BLU Supply Voltage	V_{BL_PWR}	$V_{SS} - 0.3$	26.5	V	(1), (2)
BLU Supply Current	I_{BL_PWR}	-	0.9	A	(1), (2) Vin=12V Duty 100%

Note (1) Within T_a ($25 \pm 2 \text{ }^\circ\text{C}$)

(2) Permanent damage to the device may occur if exceed maximum values

2.3 THE OTHERS

(1) STATIC ELECTRICITY PRESSURE RESISTANCE

Item	Test Conditions	Remark
CONTACT DISCHARGE	150pF, 330Ω, ± 8kV, 200points, 1 time/point	Operating
AIR DISCHARGE	150pF, 330Ω, ± 15kV, 200points, 1 time/point	Operating

3. OPTICAL CHARACTERISTICS

The following items are measured under the stable conditions.* The optical characteristics should be measured in the dark room or the equivalent environment by the methods shown in the Note (5).

Measuring equipment : TOPCON SR-3

Ta = 25 ± 2 °C, VLCD,VCC =3.3V, fv= 60Hz, fDCLK = 72.33MHz, IF = 100% duty

Item	Symbol	Condition	Min.	Typ.	Max.	Unit	Note
Contrast Ratio	CR	Normal Viewing Angle φ = 0 θ = 0	500	-	-	-	(1),(2),(5)
Response time (Rising + Falling)	T _{RT}		-	16	25	msec	(1),(3)
Average Luminance of White (5 Points)	Y _{L,AVE}		170	200	-	cd/m ²	IF=100% Duty (1),(4)
Color Chromaticity (CIE)	Red		R _X	-0.03	0.570	+0.03	
		R _Y	0.340				
	Green	G _X	0.330				
		G _Y	0.560				
	Blue	B _X	0.160				
		B _Y	0.135				
	White	W _X	0.313				
		W _Y	0.329				
Viewing Angle	Hor.	θ _L	40	45	-	Degrees	(1),(5)
		θ _H	40	45	-		
	Ver.	φ _H	10	20	-		
		φ _L	25	40	-		
Color Gamut	CG		-	45	-	%	
White variation (13P)	δ _L		-	-	1.67		(6)

Note (1) The definition of viewing angle : The range of viewing angle ($10 \leq C/R$)

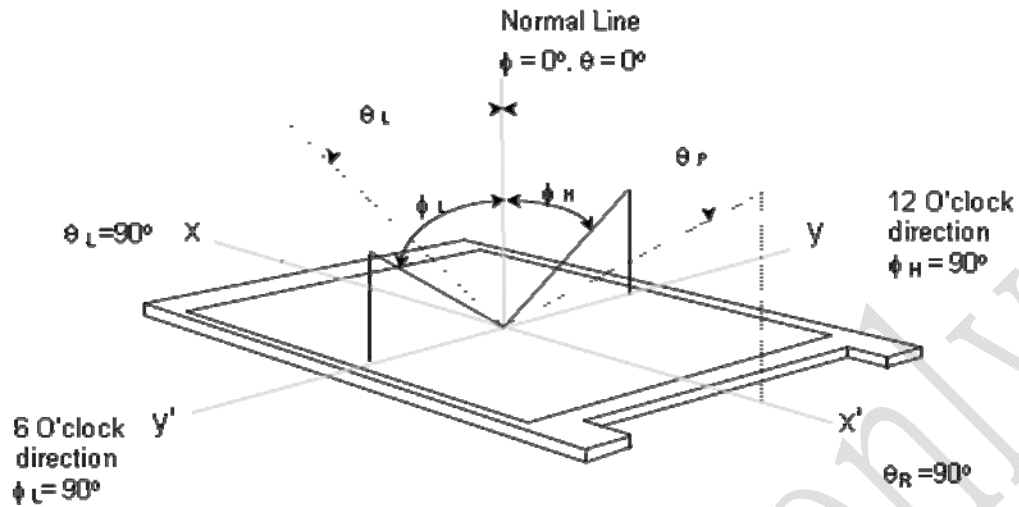

Note (2) The definition of contrast ratio (CR) : The ratio of max. gray and min gray at 5 points (4, 5, 7, 9, and 10)

$$CR = \frac{CR(4) + CR(5) + CR(7) + CR(9) + CR(10)}{5}$$

Points = 4, 5, 7, 9, 10 at the figure of Note(6).

Note (3) The definition of Response time : Subtotal of the time, during which the transmission changes from 10% to 90% when the TFT turns on and off.

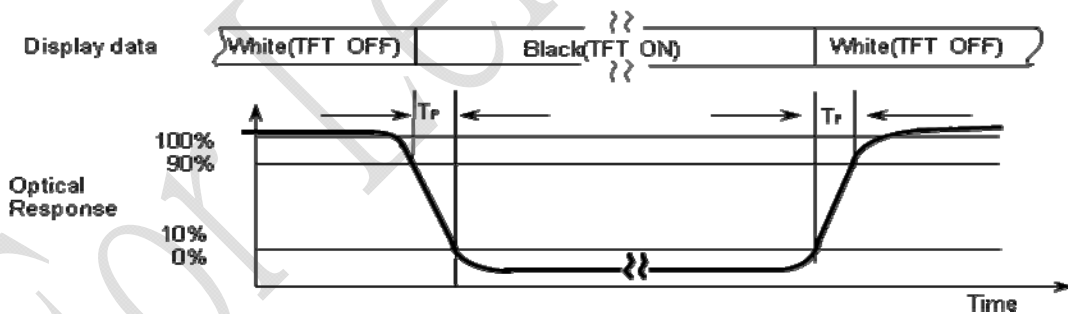

Note (4) The definition of average luminance of white : Measure the luminance of white at 5 points.

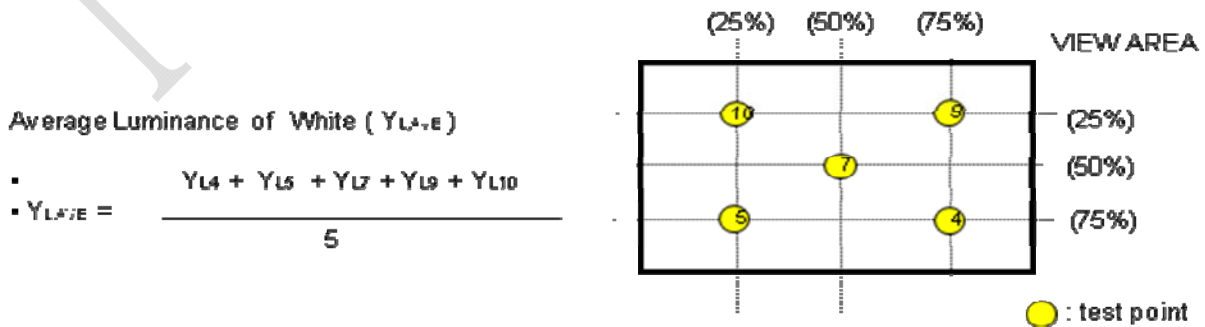

Average Luminance of White ($Y_{L\pm E}$)

$$Y_{L\pm E} = \frac{Y_{L4} + Y_{L5} + Y_{L7} + Y_{L9} + Y_{L10}}{5}$$

Note (5) Measure the panel, which is left for 30 min. at the normal temp. after leaving it for 30 min with turning the back light on at the rating. The measurement should be executed under the condition including the ambient temp., 25°C ± 2°C, the dark room, windless (removed the direct wind), and no vibration.

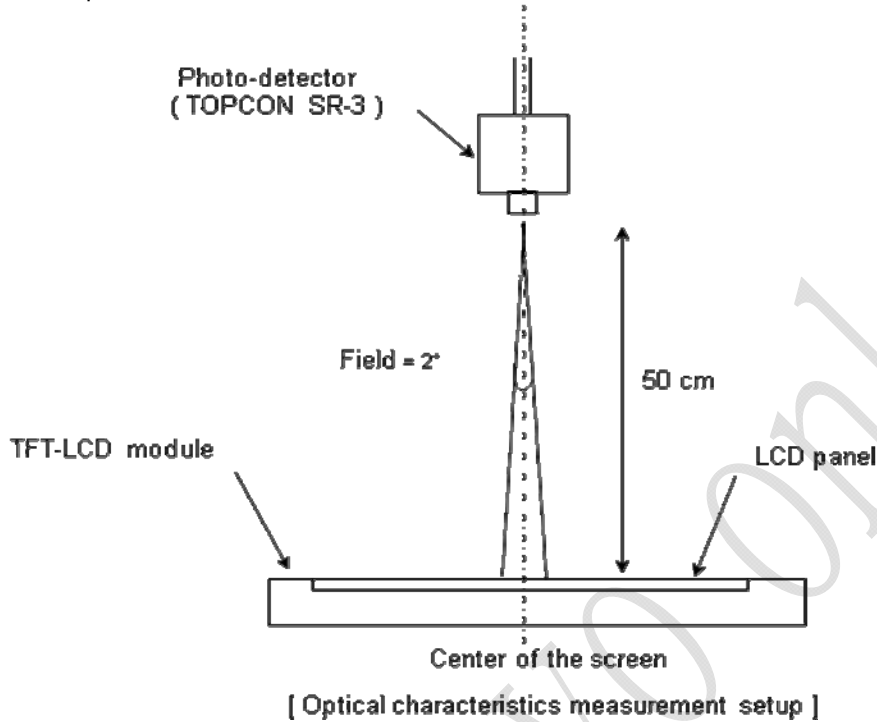

Note (6) The definition of white variation at 13 points (δL)

$$\delta L = \frac{\text{Maximum luminance of 13 points}}{\text{Minimum luminance of 13 points}}$$

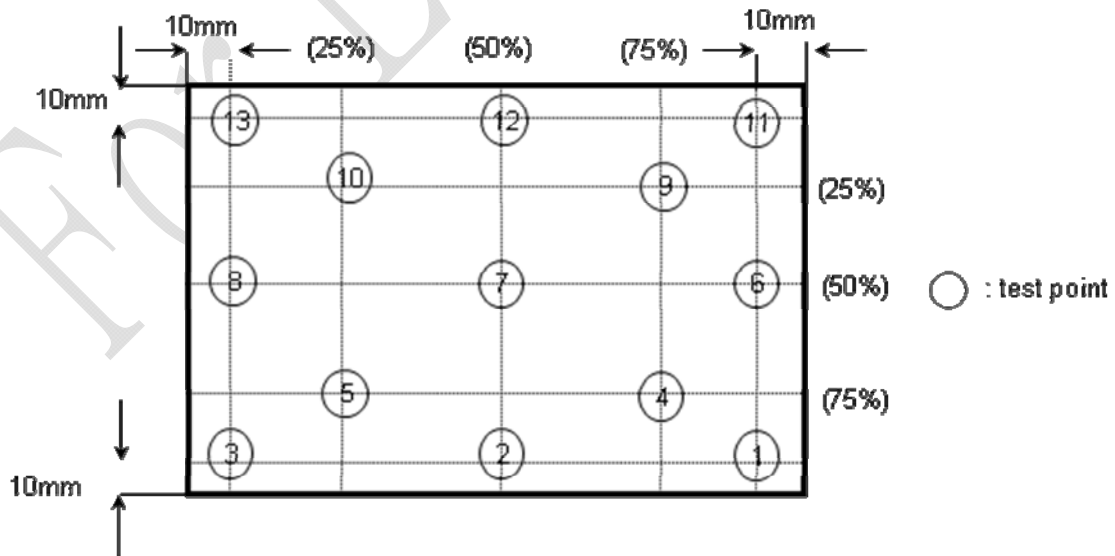

4. BLOCK DIAGRAM

4.1 TFT LCD MODULE

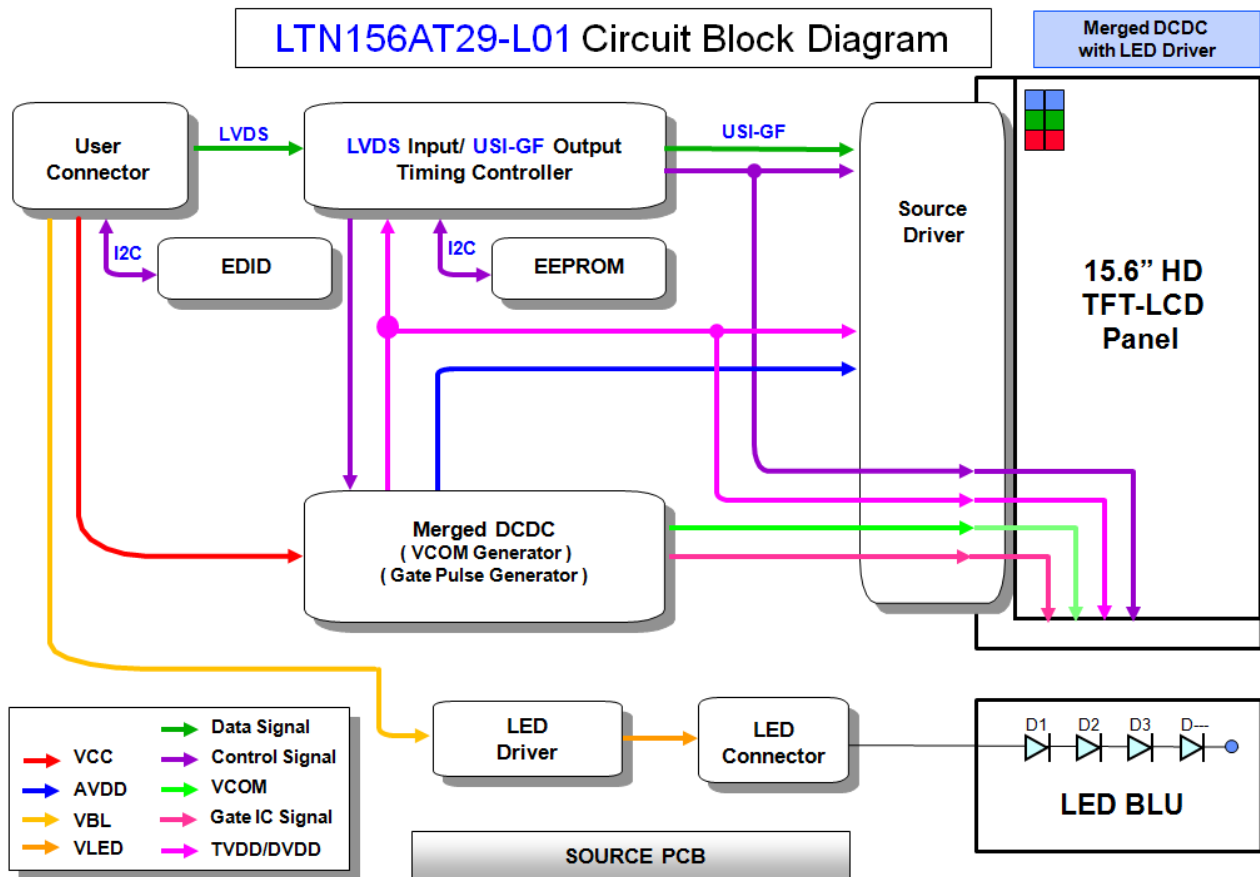

4.2 THE STRUCTURE OF LED PLACEMENT

(3 channels x 9ea = 27ea)

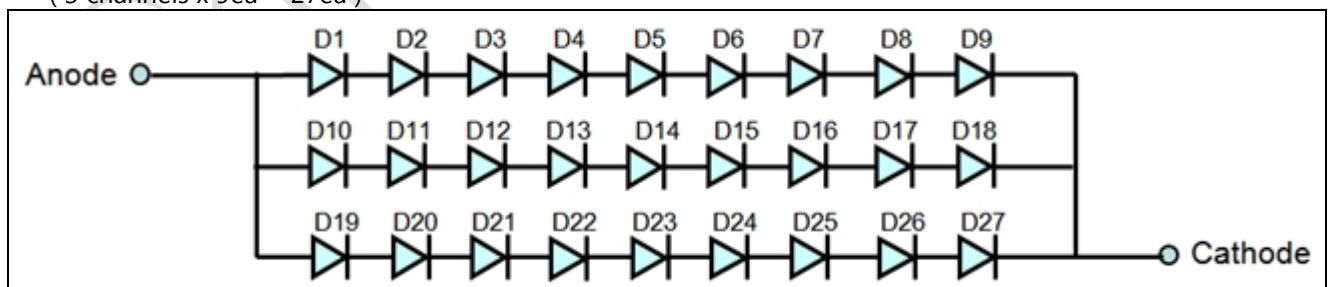

5. ELECTRICAL CHARACTERISTICS

5.1 TFT LCD MODULE

* Ta = 25 ± 2 °C

Item	Symbol	Min.	Typ.	Max.	Unit	Note	
Power Supply Voltage	V _{LCD_VCC}	3.0	3.3	3.6	V		
T-CON TTL Input Voltage	High	V _{IH}	0.7 V _{LCD_VCC}	-	-	V	(1)
	Low	V _{IL}	-	-	0.3 V _{LCD_VCC}	V	
Vsync	60Hz	f _v	-	60	-	Hz	(3)
	50Hz	f _v	-	50	-	Hz	
	40Hz	f _v	-	40	-	Hz	
Hsync	60Hz	f _h	46.50	47.40	48.60	kHz	
Main Frequency	60Hz	f _{DCLK}	67.24	72.33	83.88	MHz	
	50Hz	f _{DCLK}	-	60.28	-	MHz	
	40Hz	f _{DCLK}	-	48.22	-	MHz	
Rush Current	IRUSH	-	-	1.5	A	(5)	
Input Current	White	I _{lcd_vcc}	-	147	-	mA	(2), (4)
	Mosaic	I _{lcd_vcc}	-	146	-	mA	
	Black	I _{lcd_vcc}	-	145	-	mA	
	V.Stripe	I _{lcd_vcc}	-	247	450	mA	

Note (1) The data pins for display and signal pins for timing should be connected.(GND= 0V)

(2) f_v = 60Hz, f_{DCLK} = 72.33 MHz, V_{LCD_VCC} = 3.3V , DC Current.

(3) In the case of 40Hz & 50Hz for sDRRS, FOS, Flicker & Brightness are not guaranteed, because their level might be different from 60Hz operation.

Note (4) The dissipation pattern for power

*a) White Pattern

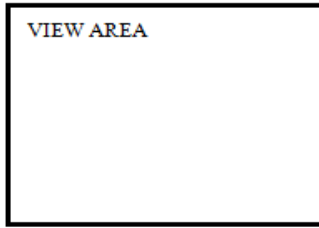

*b) Mosaic Pattern

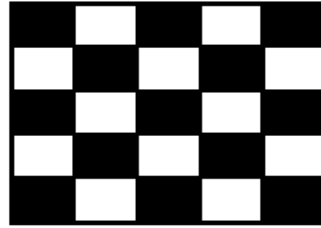

*c) Black Pattern



*d) 1 dot Vertical stripe pattern

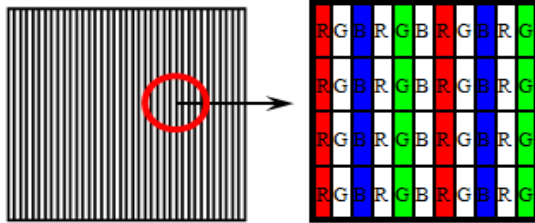

Note (5) The condition for measurement for rush current

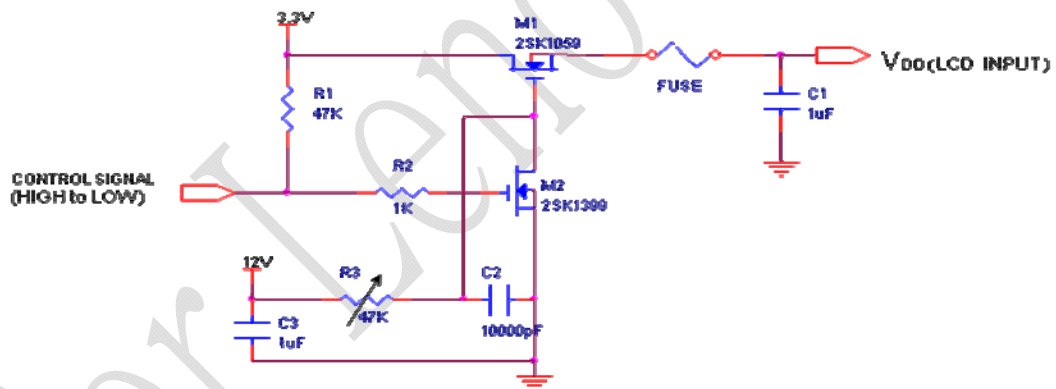

V_{DD} rising time is 470us

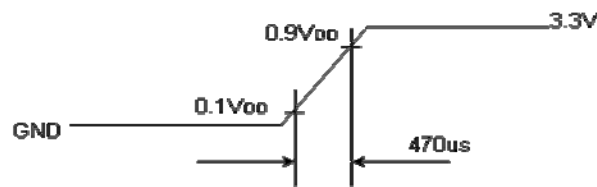

5.2 BACK LIGHT UNIT

Ta = 25 ± 2 °C

Item	Symbol	Min.	Typ.	Max.	Unit	Note
LED Forward Current	IF	-	25	-	mA	
LED Forward Voltage	VF	3.0	3.2	3.4	V	IF = 25mA
LED Array Voltage	VP	-	28.8	-	V	VF * LED Counts
LED Power Consumption	P	-	-	2.7	W	
LED Life time	Hr	12,000	-	-	Hour	(1)
LED Counts	Q	-	27	-	EA	

Note (1) The life time (Hr) of LEDs can be defined as the time during which it continues to operate under the condition, which the Ta is 25 ± 2 °C and IF= 25.0 mArms until the one of the following events occurs when the brightness becomes 50% or lower than the original..

5.3 LED DRIVER

The manufacturer of LED driver: Richtek RT8510

Ta= 25 ± 2 °C

Item	Symbol	Min.	Typ.	Max.	Unit	Note
Input Voltage	V _{BL_PWR}	5	12	21	V	
Input Current	I _{BL_PWR}	-	-	225	mA	Vin=12V Duty 100%
PWM duty Ratio	D _{BL_PWM_DIM}	0.2	-	100	%	PWM : 120Hz~500Hz
		0.4	-	100		PWM : 500Hz~1kHz
		0.8	-	100		PWM : 1kHz~2kHz
		1.5	-	100		PWM : 2kHz~5kHz
		3	-	100		PWM : 5kHz~10kHz
		10	-	100		PWM : 10kHz~30kHz
External PWM Frequency	F _{BL_PWM_DIM}	0.12	1	30	kHz	
In-Rush Current	I _{RUSH_BL_PWR}	-	-	1.5	A	(1)

Note (1) Rush current measurement condition

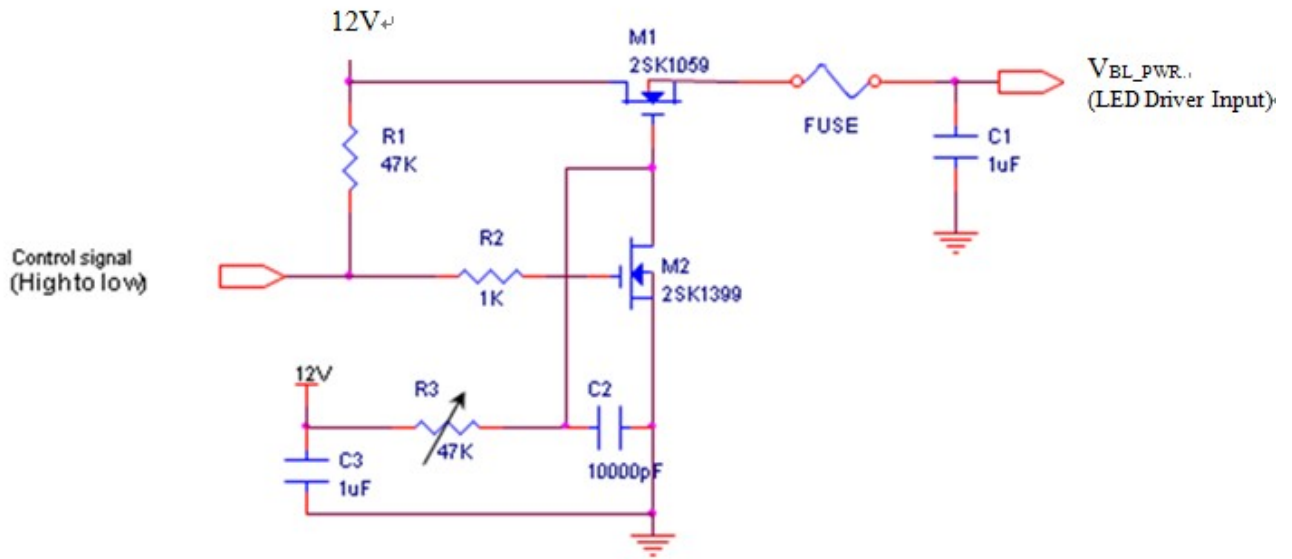

The VBL_PWR rising time is 470us.

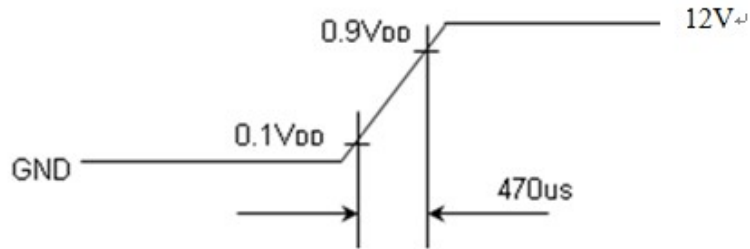

5.4 LVDS INTERFACE

LVDS DC Specifications

Characteristics	Symbol	Min.	Typ.	Max.	Unit	Conditions
Differential input high threshold voltage	V_{TH}	-	-	+200	mV	$V_{CM} = 1.2V$
Differential input low threshold voltage	V_{TL}	-200	-	-	mV	
Differential input voltage	$ V_{ID} $	200	400	600	mV	
Common mode voltage	V_{CM}	0.4	1.2	1.8	V	$ V_{ID} = 200mV$

LVDS AC Specifications

Characteristics	Symbol	Min.	Typ.	Max.	Unit	Remarks	
ROUTCLK frequency	fRCP	67.24	72.33	83.88	Mhz		
LVDS RX Skew (Strobe) Right Margin	85MHz	T_{RSRM}	-	-	400	ps	
	50MHz		-	-	700	ps	
LVDS RX Skew (Strobe) Left Margin	85MHz	T_{RSLM}	-400	-	-	ps	
	50MHz		-700	-	-	ps	

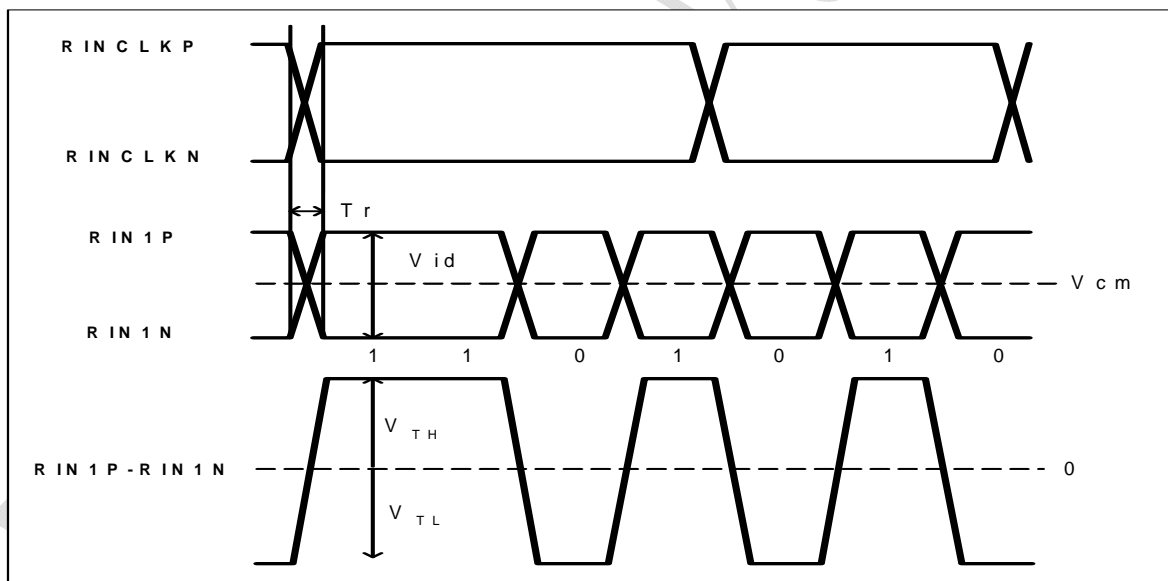

< The definition of LVDS DC characteristics >

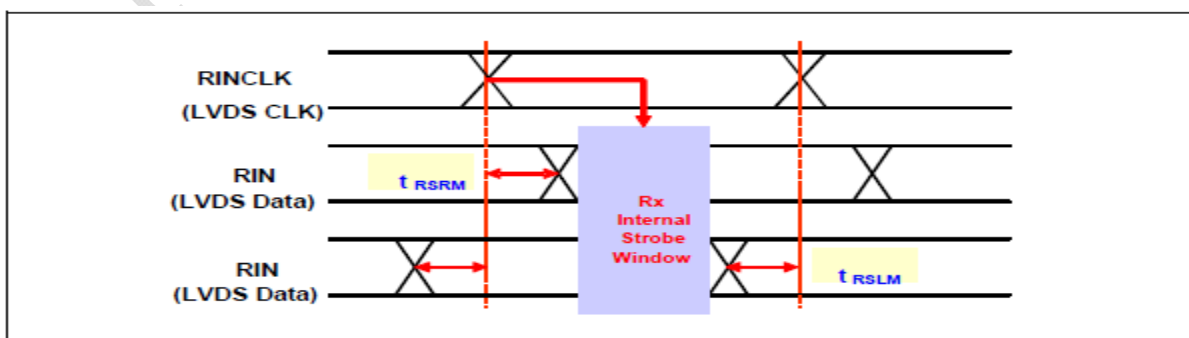

< The definition of LVDS Receiver Skew (Strobe) Margin >

LVDS SSC Specification

Characteristics	Symbol	Min.	Typ.	Max.	Unit	Remarks
Modulation Rate	Fmr	-3	0	+3	%	
Modulation Frequency	Fmf	30	-	300	kHz	@ MAINCLK = 72.33MHz

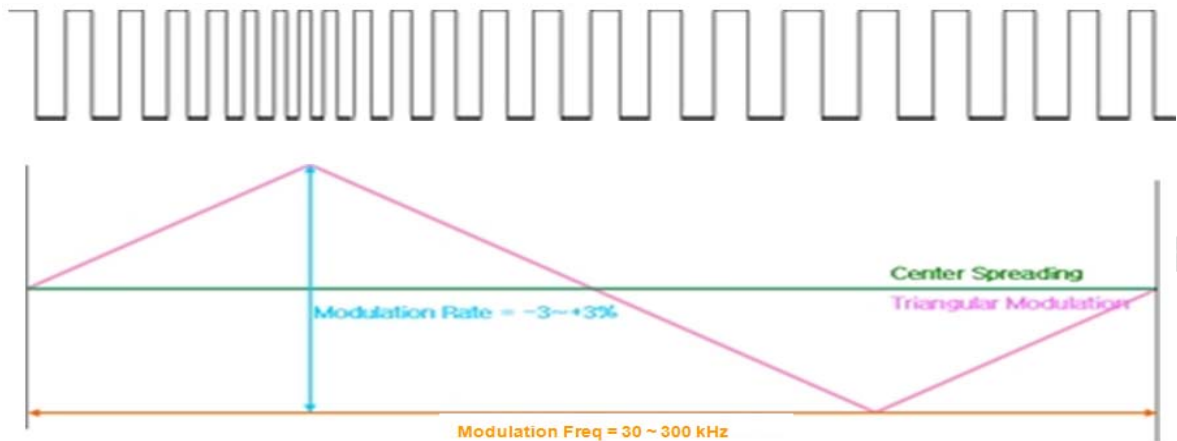

< Definition of SSC (Spread Spectrum Clock) >

Timing diagrams of LVDS transmission

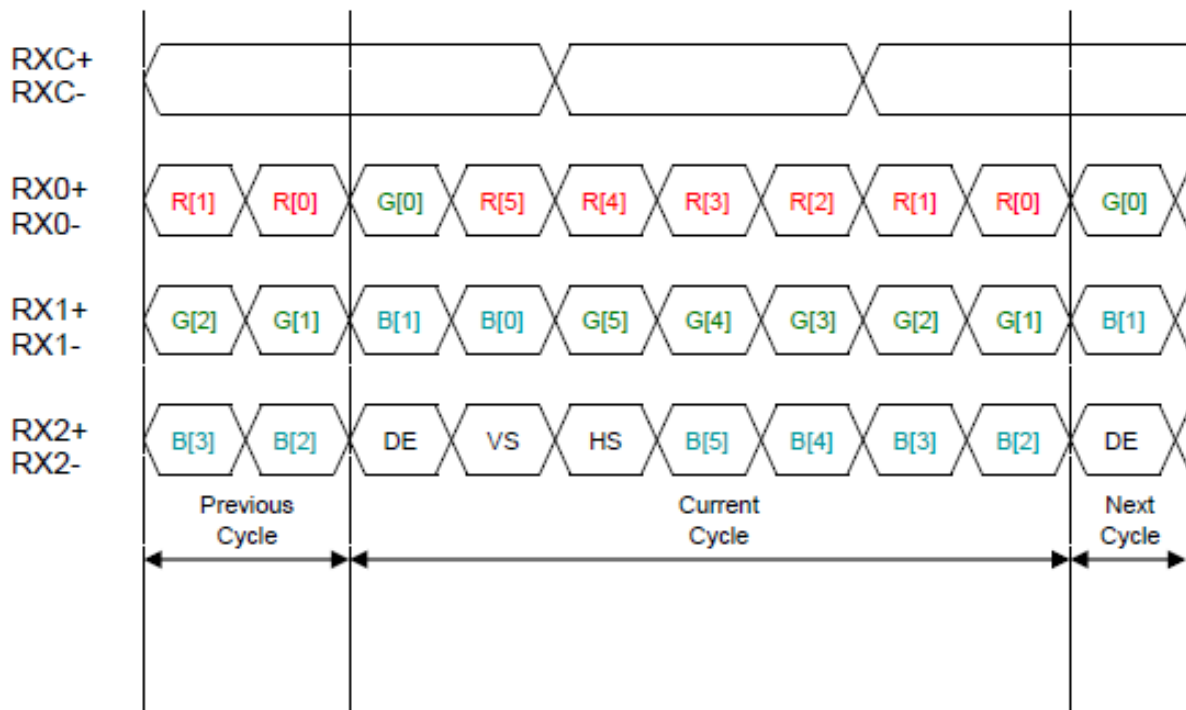

5.5 INTERFACE TIMING

5.5.1 TIMING PARAMETERS

Signal	Item	Symbol	Min.	Typ.	Max.	Unit	Note
Frame Frequency	Cycle	T_V	775	790	810	Lines	
Vertical active in the display term	Display Period	T_{VD}	-	768	-	Lines	
Scanning time in one line	Cycle	T_H	1446	1526	1726	Clocks	
Horizontal active in the display term	Display Period	T_{HD}	-	1366	-	Clocks	

5.5.2 TIMING DIAGRAMS OF INTERFACE SIGNAL

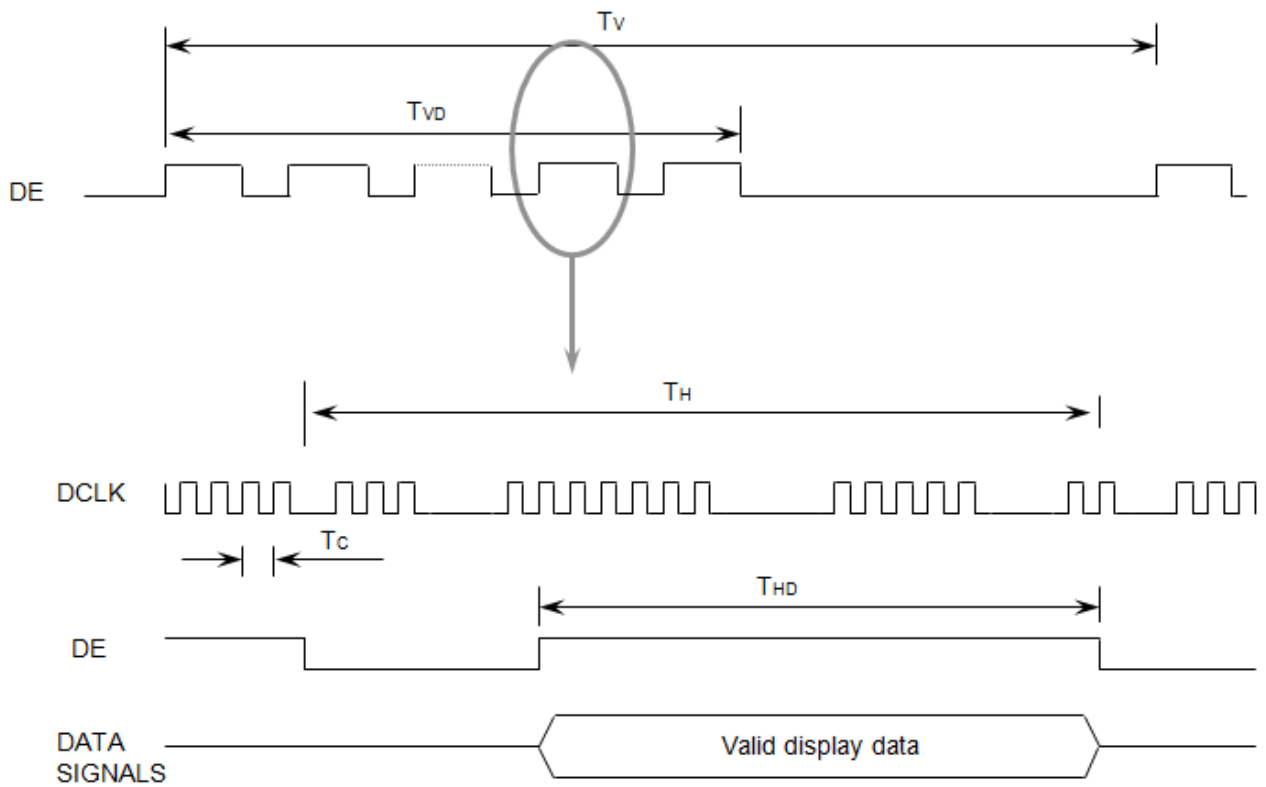

5.6 INPUT COLOR DATA MAPPING

Color	Display	Data Signal																	Gray Scale Level
		Red					Green					Blue							
		R0	R1	R2	R3	R4	R5	G0	G1	G2	G3	G4	G5	B0	B1	B2	B3	B4	
Basic Colors	Black	0	0	0	0	0	0	0	0	0	0	0	0	0	0	0	0	0	-
	Blue	0	0	0	0	0	0	0	0	0	0	0	0	1	1	1	1	1	-
	Green	0	0	0	0	0	0	1	1	1	1	1	1	0	0	0	0	0	-
	Cyan	0	0	0	0	0	0	1	1	1	1	1	1	1	1	1	1	1	-
	Red	1	1	1	1	1	1	0	0	0	0	0	0	0	0	0	0	0	-
	Magenta	1	1	1	1	1	1	0	0	0	0	0	0	1	1	1	1	1	-
	Yellow	1	1	1	1	1	1	1	1	1	1	1	1	0	0	0	0	0	-
	White	1	1	1	1	1	1	1	1	1	1	1	1	1	1	1	1	1	-
Gray Scale Of Red	Black	0	0	0	0	0	0	0	0	0	0	0	0	0	0	0	0	0	R0
	Dark	1	0	0	0	0	0	0	0	0	0	0	0	0	0	0	0	0	R1
	↑	0	1	0	0	0	0	0	0	0	0	0	0	0	0	0	0	0	R2
	:	:	:	:	:	:	:	:	:	:	:	:	:	:	:	:	:	:	R3~R60
	:	:	:	:	:	:	:	:	:	:	:	:	:	:	:	:	:	:	
	↓	1	0	1	1	1	1	0	0	0	0	0	0	0	0	0	0	0	R61
	Light	0	1	1	1	1	1	0	0	0	0	0	0	0	0	0	0	0	R62
	Red	1	1	1	1	1	1	0	0	0	0	0	0	0	0	0	0	0	R63
Gray Scale Of Green	Black	0	0	0	0	0	0	0	0	0	0	0	0	0	0	0	0	0	G0
	Dark	0	0	0	0	0	0	1	0	0	0	0	0	0	0	0	0	0	G1
	↑	0	0	0	0	0	0	0	1	0	0	0	0	0	0	0	0	0	G2
	:	:	:	:	:	:	:	:	:	:	:	:	:	:	:	:	:	:	G3~G60
	:	:	:	:	:	:	:	:	:	:	:	:	:	:	:	:	:	:	
	↓	0	0	0	0	0	0	1	0	1	1	1	1	0	0	0	0	0	G61
	Light	0	0	0	0	0	0	0	1	1	1	1	1	0	0	0	0	0	G62
	Green	0	0	0	0	0	0	1	1	1	1	1	1	0	0	0	0	0	G63
Gray Scale Of Blue	Black	0	0	0	0	0	0	0	0	0	0	0	0	0	0	0	0	0	B0
	Dark	0	0	0	0	0	0	0	0	0	0	0	1	0	0	0	0	0	B1
	↑	0	0	0	0	0	0	0	0	0	0	0	0	1	0	0	0	0	B2
	:	:	:	:	:	:	:	:	:	:	:	:	:	:	:	:	:	:	B3~B60
	:	:	:	:	:	:	:	:	:	:	:	:	:	:	:	:	:	:	
	↓	0	0	0	0	0	0	0	0	0	0	0	0	1	0	1	1	1	B61
	Light	0	0	0	0	0	0	0	0	0	0	0	0	0	1	1	1	1	B62
	Blue	0	0	0	0	0	0	0	0	0	0	0	0	1	1	1	1	1	B63

Note (1) Definition of gray : Rn: Red gray, Gn: Green gray, Bn: Blue gray (n=gray level)

Note (2) Input signal: 0 =Low level voltage, 1=High level voltage

5.7 POWER ON/OFF SEQUENCE

To prevent the product from being latched up or the DC in the LCD module from starting an operation, the order to turn the power on and off should be changed to the order as shown in the diagram below.

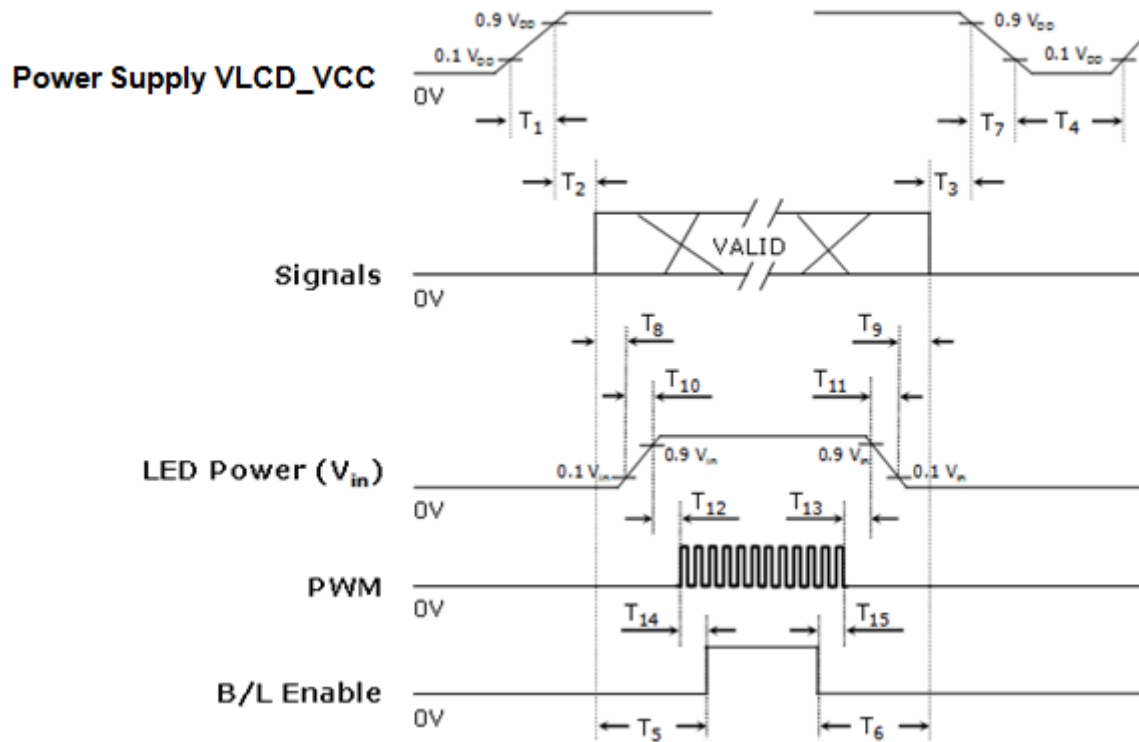

Timing (ms)	Remarks
$0.5 < T_1 \leq 10$	VLCD_VCC rising time from 10% to 90%
$0 < T_2 \leq 50$	Interval from VLCD_VCC to valid data at power ON
$0 < T_3 \leq 50$	Interval from valid data OFF to VLCD_VCC OFF at power Off
$150 \leq T_4$	VLCD_VCC OFF time for Windows restart
$200 \leq T_5$	Interval from valid data to B/L enable at power ON
$200 \leq T_6$	Interval from valid data off to B/L disable at power Off
$0 < T_7 \leq 10$	VLCD_VCC falling time from 90% to 10%
$10 < T_8$	Interval from valid data on to LED driver V _{in} rising time 10%
$10 < T_9$	Interval from LED driver V _{in} falling time 10% to valid data Off
$0.5 < T_{10} \leq 10$	LED V _{in} rising time from 10% to 90%
$0.5 < T_{11} \leq 10$	LED V _{in} falling time from 90% to 10%
$0 < T_{12}$	Interval from LED driver V _{in} rising time 90% to PWM ON
$0 < T_{13}$	Interval from PWM Off to LED driver V _{in} falling time 90%
$0 \leq T_{14}$	Interval from PWM ON to B/L Enable ON
$0 \leq T_{15}$	Interval from B/L Enable Off to PWM Off

The backlight may be flashed if the interface signal remains floated when the above-mentioned signal becomes invalid.

- Note
- (1) The power voltage from system shall be supplied to the input pin of LCD constantly.
 - (2) Enable the voltage to the LED within the range, which the LCD is operated. The screen becomes white when turning the back-light on before the LCD is operated or turning the LCD off before turning the back-light off. Operation or the LCD turns off before the back-light turns off, the display may momentarily become white.
 - (3) Don't leave the system at a high impedance state, which the interface signal is out for a long time after the Vcc is enabled.
 - (4) The T4 should be measured the module is fully discharged.
 - (5) The interface signal shall not maintain the high impedance when the power is on.

FOR Lenovo Only

5.8 INPUT TERMINAL PIN ASSIGNMENT

5.8.1 INPUT SIGNAL & POWER

(LVDS, Connector : 20455-040E-0 , I-PEX or the equipment with the equivalent capability)

Pin	Symbol	Function
1	NC	Hot Plug Detect or No connection (optional)
2	LCD_VCC	LCD logic and driver IC Power(3.3V typ.)
3	LCD_VCC	LCD logic and driver IC Power(3.3V typ.)
4	VCC_EDID	DDC power
5	NC (WPN)	Reserved for the use by LCD manufacturer (WPN)
6	CLK_EDID	DDC clock
7	DAT_EDID	DDC data
8	RX0-	Negative LVDS differential data input for pixel
9	RX0+	Positive LVDS differential data input for pixel
10	H_GND	High speed ground
11	RX1-	Negative LVDS differential data input for pixel
12	RX1+	Positive LVDS differential data input for pixel
13	H_GND	High speed ground
14	RX2-	Negative LVDS differential data input for pixel
15	RX2+	Positive LVDS differential data input for pixel
16	H_GND	High speed ground
17	RXC-	Negative LVDS differential clock input for pixel
18	RXC+	Positive LVDS differential clock input for pixel
19	LCD_GND	LCD logic and driver IC Ground
20	NC	No connection
21	NC	No connection
22	LCD_GND	LCD logic and driver IC Ground
23	NC	No connection
24	NC	No connection
25	LCD_GND	LCD logic and driver IC Ground
26	NC	No connection
27	NC	No connection
28	LCD_GND	LCD logic and driver IC Ground
29	NC	No connection
30	NC	No connection
31	BL_GND	Backlight ground
32	BL_GND	Backlight ground
33	BL_GND	Backlight ground
34	NC	Hot Plug Detect or No connection (optional)
35	BL_PWM_DIM	Signal input for the system PWM for dimming
36	BL_ENABLE	Backlight on/off
37	NC	APS on/off or No connection (optional)
38	BL_PWR	Backlight power
39	BL_PWR	Backlight power
40	BL_PWR	Backlight power

6. PIXEL FORMAT

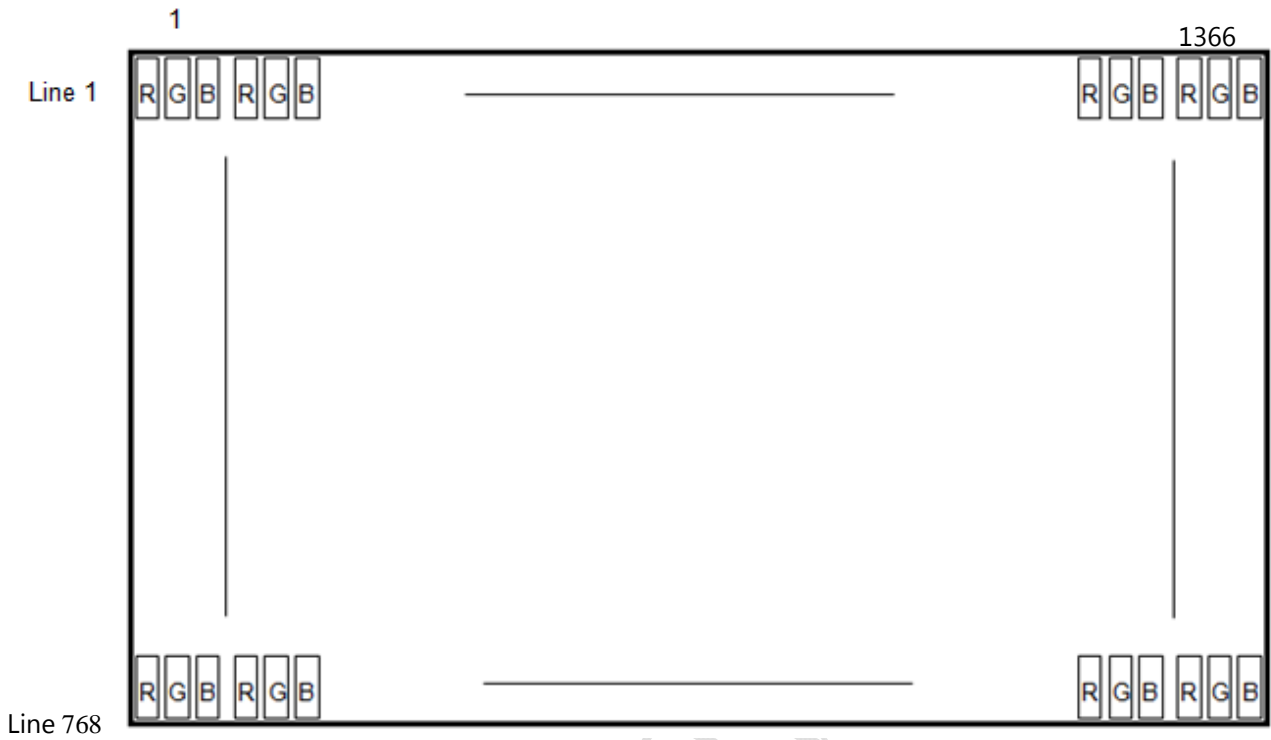

7. OUTLINE DIMENSION

[Refer to next page]

For Lenovo Only

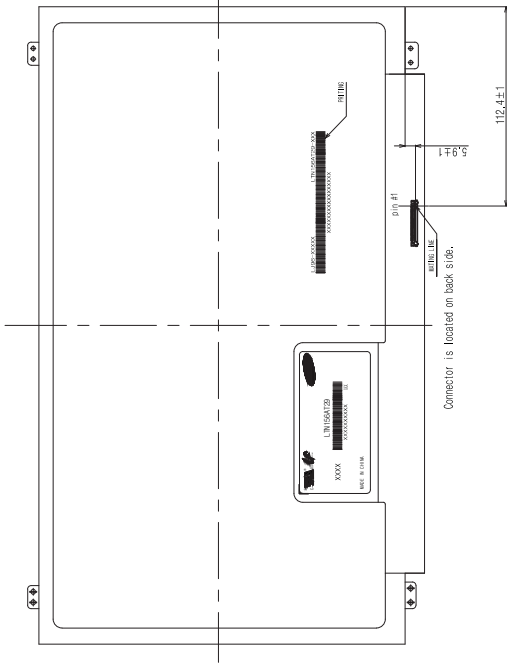
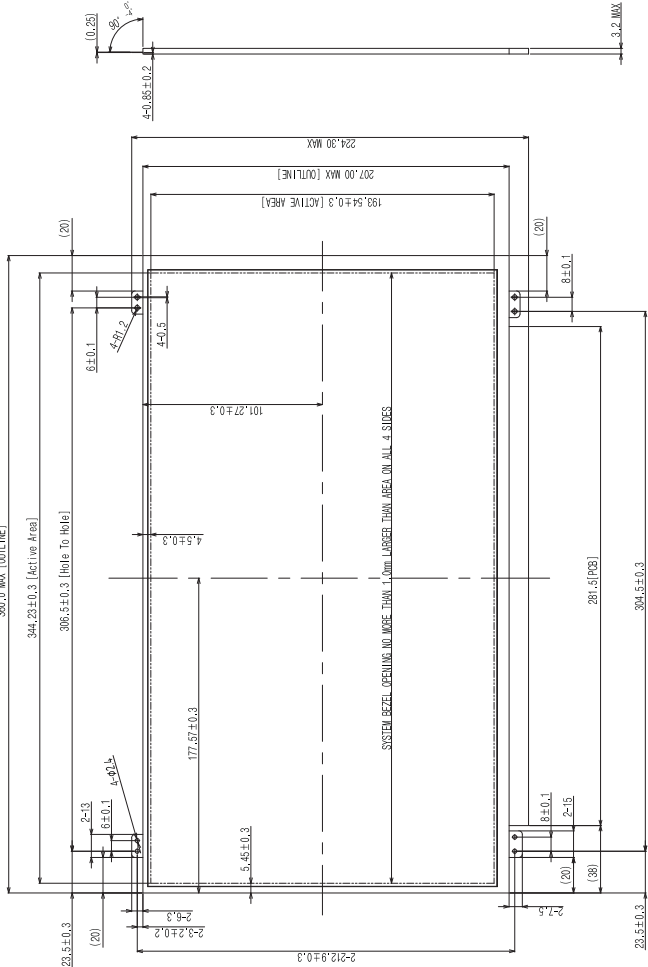

*** NOTE**

1. **INPUT SIGNAL CONNECTOR TO BE SPECIFIED AS BELOW.**
 MAKER / PART NO. : I-PEX / 20455-040E-02S (or compatible)
2. **THICKNESS Measuring Method**
 BODY part : By Micrometer
 COF part : 50g Force with Height Gauge
3. **WEIGHT : 380g MAX.**

LTN156AT29-L01 OUTLINE

Samsung Confidential

REV	DESCRIPTION	DATE	BY	CHK	APP
01	INITIAL RELEASE	10/13	W.S. JUNG	W.S. JUNG	W.S. JUNG
02	REVISION	10/21	W.S. JUNG	W.S. JUNG	W.S. JUNG
03	REVISION	11/07	W.S. JUNG	W.S. JUNG	W.S. JUNG
04	REVISION	12/25	W.S. JUNG	W.S. JUNG	W.S. JUNG
05	REVISION	12/28	W.S. JUNG	W.S. JUNG	W.S. JUNG
06	REVISION	01/04	W.S. JUNG	W.S. JUNG	W.S. JUNG
07	REVISION	02/04	W.S. JUNG	W.S. JUNG	W.S. JUNG
08	REVISION	02/11	W.S. JUNG	W.S. JUNG	W.S. JUNG
09	REVISION	02/12	W.S. JUNG	W.S. JUNG	W.S. JUNG
10	REVISION	02/15	W.S. JUNG	W.S. JUNG	W.S. JUNG
11	REVISION	02/21	W.S. JUNG	W.S. JUNG	W.S. JUNG
12	REVISION	02/22	W.S. JUNG	W.S. JUNG	W.S. JUNG
13	REVISION	02/25	W.S. JUNG	W.S. JUNG	W.S. JUNG
14	REVISION	02/26	W.S. JUNG	W.S. JUNG	W.S. JUNG
15	REVISION	02/28	W.S. JUNG	W.S. JUNG	W.S. JUNG
16	REVISION	02/28	W.S. JUNG	W.S. JUNG	W.S. JUNG
17	REVISION	03/01	W.S. JUNG	W.S. JUNG	W.S. JUNG
18	REVISION	03/02	W.S. JUNG	W.S. JUNG	W.S. JUNG
19	REVISION	03/03	W.S. JUNG	W.S. JUNG	W.S. JUNG
20	REVISION	03/03	W.S. JUNG	W.S. JUNG	W.S. JUNG
21	REVISION	03/04	W.S. JUNG	W.S. JUNG	W.S. JUNG
22	REVISION	03/05	W.S. JUNG	W.S. JUNG	W.S. JUNG
23	REVISION	03/05	W.S. JUNG	W.S. JUNG	W.S. JUNG
24	REVISION	03/05	W.S. JUNG	W.S. JUNG	W.S. JUNG
25	REVISION	03/05	W.S. JUNG	W.S. JUNG	W.S. JUNG
26	REVISION	03/05	W.S. JUNG	W.S. JUNG	W.S. JUNG
27	REVISION	03/05	W.S. JUNG	W.S. JUNG	W.S. JUNG
28	REVISION	03/05	W.S. JUNG	W.S. JUNG	W.S. JUNG
29	REVISION	03/05	W.S. JUNG	W.S. JUNG	W.S. JUNG
30	REVISION	03/05	W.S. JUNG	W.S. JUNG	W.S. JUNG
31	REVISION	03/05	W.S. JUNG	W.S. JUNG	W.S. JUNG
32	REVISION	03/05	W.S. JUNG	W.S. JUNG	W.S. JUNG
33	REVISION	03/05	W.S. JUNG	W.S. JUNG	W.S. JUNG
34	REVISION	03/05	W.S. JUNG	W.S. JUNG	W.S. JUNG
35	REVISION	03/05	W.S. JUNG	W.S. JUNG	W.S. JUNG
36	REVISION	03/05	W.S. JUNG	W.S. JUNG	W.S. JUNG
37	REVISION	03/05	W.S. JUNG	W.S. JUNG	W.S. JUNG
38	REVISION	03/05	W.S. JUNG	W.S. JUNG	W.S. JUNG
39	REVISION	03/05	W.S. JUNG	W.S. JUNG	W.S. JUNG
40	REVISION	03/05	W.S. JUNG	W.S. JUNG	W.S. JUNG

REV	DESCRIPTION	DATE	BY	CHK	APP
01	INITIAL RELEASE	10/13	W.S. JUNG	W.S. JUNG	W.S. JUNG
02	REVISION	10/21	W.S. JUNG	W.S. JUNG	W.S. JUNG
03	REVISION	11/07	W.S. JUNG	W.S. JUNG	W.S. JUNG
04	REVISION	12/25	W.S. JUNG	W.S. JUNG	W.S. JUNG
05	REVISION	12/28	W.S. JUNG	W.S. JUNG	W.S. JUNG
06	REVISION	01/04	W.S. JUNG	W.S. JUNG	W.S. JUNG
07	REVISION	02/04	W.S. JUNG	W.S. JUNG	W.S. JUNG
08	REVISION	02/11	W.S. JUNG	W.S. JUNG	W.S. JUNG
09	REVISION	02/12	W.S. JUNG	W.S. JUNG	W.S. JUNG
10	REVISION	02/15	W.S. JUNG	W.S. JUNG	W.S. JUNG
11	REVISION	02/21	W.S. JUNG	W.S. JUNG	W.S. JUNG
12	REVISION	02/22	W.S. JUNG	W.S. JUNG	W.S. JUNG
13	REVISION	02/25	W.S. JUNG	W.S. JUNG	W.S. JUNG
14	REVISION	02/26	W.S. JUNG	W.S. JUNG	W.S. JUNG
15	REVISION	02/28	W.S. JUNG	W.S. JUNG	W.S. JUNG
16	REVISION	02/28	W.S. JUNG	W.S. JUNG	W.S. JUNG
17	REVISION	03/01	W.S. JUNG	W.S. JUNG	W.S. JUNG
18	REVISION	03/02	W.S. JUNG	W.S. JUNG	W.S. JUNG
19	REVISION	03/03	W.S. JUNG	W.S. JUNG	W.S. JUNG
20	REVISION	03/03	W.S. JUNG	W.S. JUNG	W.S. JUNG
21	REVISION	03/04	W.S. JUNG	W.S. JUNG	W.S. JUNG
22	REVISION	03/05	W.S. JUNG	W.S. JUNG	W.S. JUNG
23	REVISION	03/05	W.S. JUNG	W.S. JUNG	W.S. JUNG
24	REVISION	03/05	W.S. JUNG	W.S. JUNG	W.S. JUNG
25	REVISION	03/05	W.S. JUNG	W.S. JUNG	W.S. JUNG
26	REVISION	03/05	W.S. JUNG	W.S. JUNG	W.S. JUNG
27	REVISION	03/05	W.S. JUNG	W.S. JUNG	W.S. JUNG
28	REVISION	03/05	W.S. JUNG	W.S. JUNG	W.S. JUNG
29	REVISION	03/05	W.S. JUNG	W.S. JUNG	W.S. JUNG
30	REVISION	03/05	W.S. JUNG	W.S. JUNG	W.S. JUNG
31	REVISION	03/05	W.S. JUNG	W.S. JUNG	W.S. JUNG
32	REVISION	03/05	W.S. JUNG	W.S. JUNG	W.S. JUNG
33	REVISION	03/05	W.S. JUNG	W.S. JUNG	W.S. JUNG
34	REVISION	03/05	W.S. JUNG	W.S. JUNG	W.S. JUNG
35	REVISION	03/05	W.S. JUNG	W.S. JUNG	W.S. JUNG
36	REVISION	03/05	W.S. JUNG	W.S. JUNG	W.S. JUNG
37	REVISION	03/05	W.S. JUNG	W.S. JUNG	W.S. JUNG
38	REVISION	03/05	W.S. JUNG	W.S. JUNG	W.S. JUNG
39	REVISION	03/05	W.S. JUNG	W.S. JUNG	W.S. JUNG
40	REVISION	03/05	W.S. JUNG	W.S. JUNG	W.S. JUNG

8. RELIABILITY TEST

Item		Condition	Time/Cycle
HTOL		55 °C	500 hrs
LTOL		-5 °C	500 hrs
HTS		70 °C	500 hrs
LTS		-25 °C	500 hrs
THB		50 °C, 90%	500 hrs
WHTS		60 °C, 75%	500 hrs
T/C		-40 °C/30min ~ 65 °C/30min	50 cycles
ESD	Non-operating	CDM : 150pF, 330Ω, 9point, 3 times/point	±10kV
	Operating	Contact : 150 pF, 330Ω, 100point, once/point	±8kV
		Air(non-contact) : 150pF, 330Ω, 100point, once/point	±15kV
Box Vibration (Non-operating)		5~200Hz, 1.05Grms, 2hr/Y	1time
Shock (Non-operating)		240G, 2msec, ±XYZ	30min/axis
HINGE		10~170°, Open/Close 2sec, Pause1sec	30Kcycle
Altitude		-40~50 °C, 0~45,000ft	72.5Hr

[Result Evaluation Criteria]

Under the display quality test conditions with normal operation state, these should be no change which may affect practical display functions.

9. PACKING

9.1 CARTON

(1) Packing Form

Corrugated Cardboard box and Corrupad form as shock absorber.

(2) Packing Method

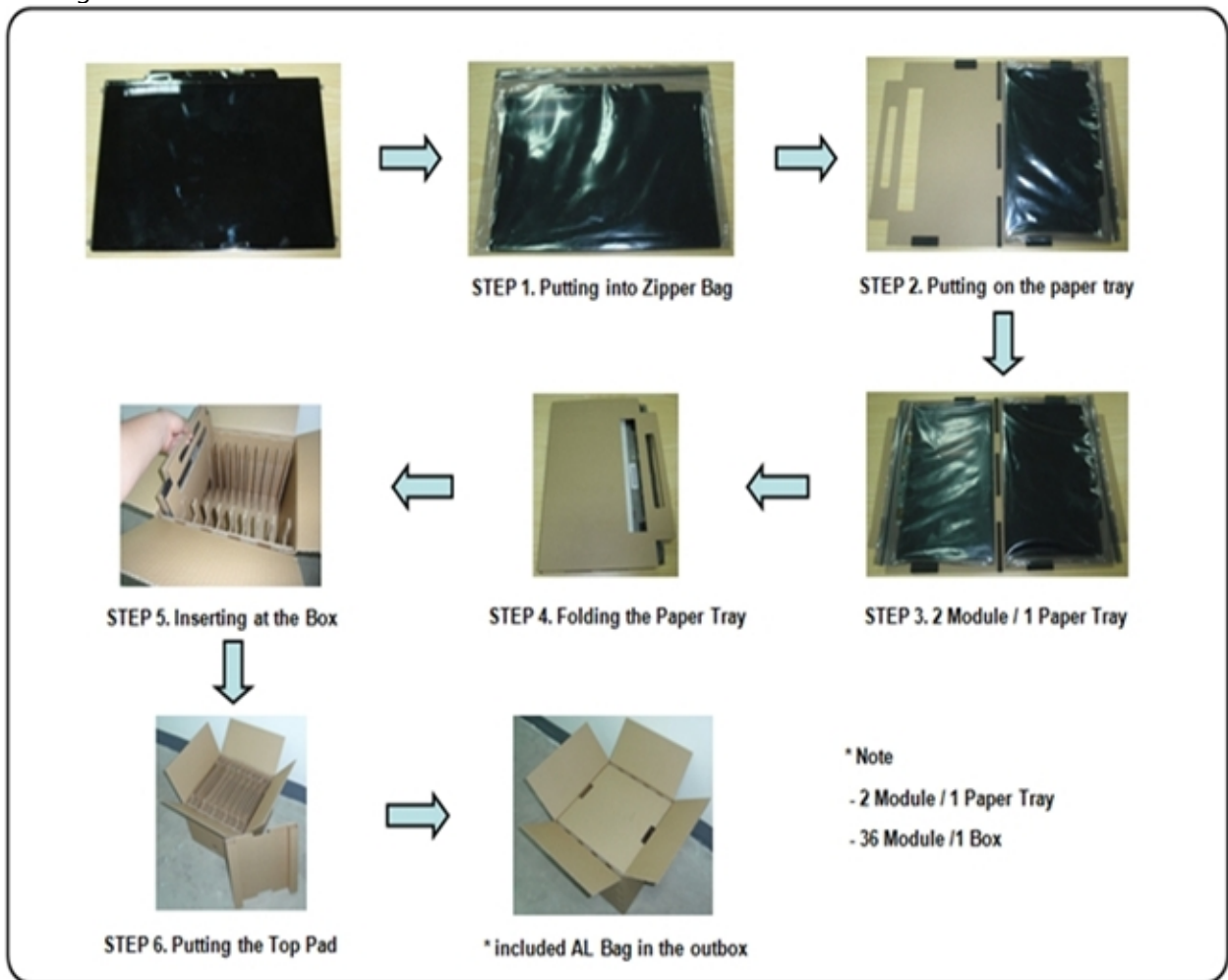

Note (1) Total Weight : Approximately 18 Kg

(2) Acceptance number of piling : 36 sets

(3) Carton size : 373(W) × 470(D) × 372(H))

(3) Packing Material

No	Part name	Quantity
1	Static electric protective sack	36 pcs
2	Packing case (Inner box) included shock absorber	1 set
3	Pictorial marking	2
4	Carton	1 set

9.2 MARKING

A nameplate is affixed to the specified location on each product.

(1)Parts number : LTN156AT29-L01

(2)Revision code : 3 letters

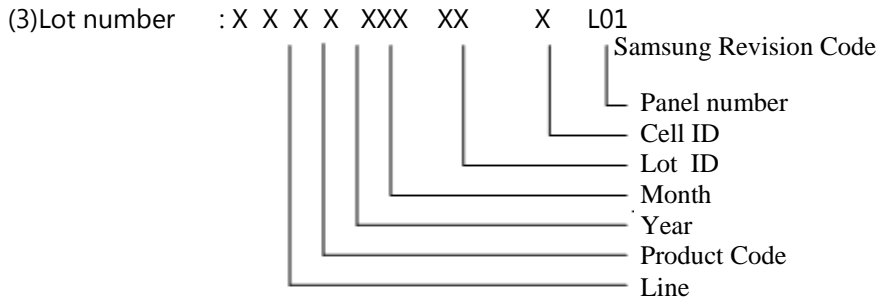

(4) Nameplate Indication

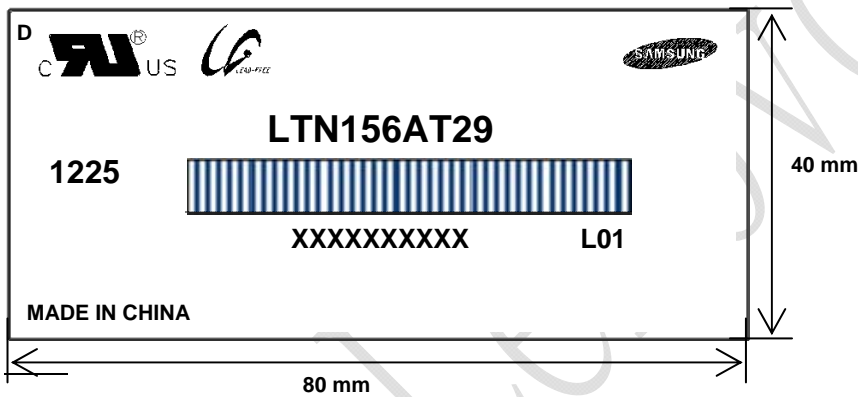

Parts name : LTN156AT29 -L01
 Lot number : XXXXXXXXXXXX
 Inspected work week : 1225 (2012 year 25th week)
 Product Revision Code : L01

(5) Packing small box attach

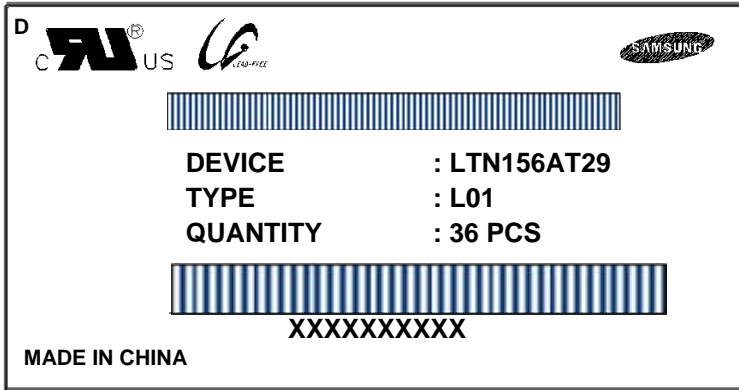

For Lenovo Only

10. GENERAL PRECAUTIONS

10.1 HANDLING

- (a) When the module is assembled, It should be attached to the system firmly using every mounting holes. Be careful not to twist and bend the modules.
- (b) Refrain from strong mechanical shock and / or any force to the module. In addition to damage, this may cause improper operation or damage to the module and CCFT back-light.
- (c) Note that polarizers are very fragile and could be easily damaged. Do not press or scratch the surface harder than a HB pencil lead.
- (d) Wipe off water droplets or oil immediately. If you leave the droplets for a long time, Staining and discoloration may occur.
- (e) If the surface of the polarizer is dirty, clean it using some absorbent cotton or soft cloth.
- (f) The desirable cleaners are water, IPA (Isopropyl Alcohol) or Hexane. Do not use Ketone type materials(ex. Acetone), Ethyl alcohol, Toluene, Ethyl acid or Methyl chloride. It might permanent damage to the polarizer due to chemical reaction.
- (g) If the liquid crystal material leaks from the panel, it should be kept away from the eyes or mouth .In case of contact with hands, legs or clothes, it must be washed away thoroughly with soap.
- (h) Protect the module from static , it may cause damage to the C-MOS Gate Array IC.
- (i) Use fingerstalls with soft gloves in order to keep display clean during the incoming inspection and assembly process.
- (j) Do not disassemble the module.
- (k) Do not pull or fold the LED FPC.
- (l) Do not touch any component which is located on the back side.
- (m) Protection film for polarizer on the module shall be slowly peeled off just before use so that the electrostatic charge can be minimized.
- (n) Pins of I/F connector shall not be touched directly with bare hands.

10.2 STORAGE

We highly recommend to comply with the criteria in the table below.

ITEM	Unit	Min.	Max.
Storage Temperature	(°C)	5	40
Storage Humidity	(%rH)	35	75
Storage Life	12 months		
Storage Condition	<ul style="list-style-type: none"> - The storage room should be equipped with a good ventilation facility, which has a temperature controlling system. - Products should be placed on the pallet, which is away from the wall not on the floor. - Prevent products from being exposed to the direct sunlight, moisture, and water.; Be cautious not to pile the products up. - Avoid storing products in the environment, which other hazardous material is placed. - If products are delivered or kept in the storage facility more than 3 months, we recommend you to leave products under the condition including a 20°C temperature and a humidity of 50% for 24 hours. - If you store semi-manufactured products for more than 3 months, bake the products under the condition including the 50°C temp. and the 10% humidity for 24hrs after being used. 		

10.3 OPERATION

- (a) Do not connect, disconnect the module in the " Power On" condition.
- (b) Power supply should always be turned on/off by following item 6.3 " Power on/off sequence ".
- (c) Module has high frequency circuits. Sufficient suppression to the electromagnetic interference shall be done by system manufacturers. Grounding and shielding methods may be important to minimize the interference.
- (d) The FPC cable between the LED chips and its converter power supply shall be a minimized length and be connected directly .The longer cable between the back-light and the converter may cause lower luminance of light source (LED).
- (e) The standard limited warranty is only applicable when the module is used for general notebook applications. If used for purposes other than as specified, SEC is not to be held reliable for the defective operations. It is strongly recommended to contact SEC to find out fitness for a particular purpose.

10.4 OTHERS

- (a) Ultra-violet ray filter is necessary for outdoor operation.
- (b) Avoid condensation of water. It may result in improper operation or disconnection of electrode.
- (c) Do not exceed the absolute maximum rating value. (the supply voltage variation, input voltage variation, Variation in part contents and environmental temperature, so on) Otherwise the module may be damaged.
- (d) If the module displays the same pattern continuously for a long period of time, it can be the situation when The image "sticks" to the screen.
- (e) This module has its circuitry PCB's on the rear side and should be handled carefully in order not to be stressed.

FOR Lenovo Only

11. EDID

Address (HEX)	FUNCTION	Value	BIN	DEC	ASCII or Data	Notes
		HEX				
00	Header	00	00000000	0		EDID Header
01		FF	11111111	255		
02		FF	11111111	255		
03		FF	11111111	255		
04		FF	11111111	255		
05		FF	11111111	255		
06		FF	11111111	255		
07		00	00000000	0		
08	ID Manufacturer Name	4C	01001100	76	S	3 character ID
09		83	10000011	131	D	"SDC"
0A		45	01000101	69	C	
0B	ID Product Code	52	01010010	82	[R]	
0C		45	01000101	69	[E]	
0D	32-bit serial no.	00	00000000	0		
0E		00	00000000	0		
0F		00	00000000	0		
10		00	00000000	0		
11	Week of manufacture	00	00000000	0		
12	Year of manufacture	16	00010110	22	2012	2012
13	EDID Structure Ver.	01	00000001	1	1	EDID Ver. 1.0
14	EDID revision #	03	00000011	3	3	EDID Rev. 3
15	Video input definition	80	10000000	128		
16	Max H image size	22	00100010	34	34	34 cm(approx)
17	Max V image size	13	00010011	19	19	19 cm(approx)
18	Display Gamma	78	01111000	120	2.2	Gamma 2.2
19	Feature support	0A	00001010	10		
1A	Red/green low bits	09	00001001	9		10000111
1B	Blue/white low bits	25	00100101	37		11111110
1C	Red x/ high bits	92	10010010	146	0.570	Red x0.570= 10010010
1D	Red y	57	01010111	87	0.340	Red y0.340= 01010111
1E	Green x	54	01010100	84	0.330	Green x0.330= 01010100
1F	Green y	8F	10001111	143	0.560	Green y0.560= 10001111
20	Blue x	29	00101001	41	0.160	Blue x0.160= 00101001
21	Blue y	22	00100010	34	0.135	Blue y0.135= 00100010
22	White x	50	01010000	80	0.313	White x0.313= 01010000
23	White y	54	01010100	84	0.329	White y0.329= 01010100
24	Established timing 1	00	00000000	0		
25	Established timing 2	00	00000000	0		
26	Established timing 3	00	00000000	0		
27	Standard timing #1	01	00000001	1		not used
28	Standard timing #2	01	00000001	1		not used
29	Standard timing #3	01	00000001	1		not used

2A	Standard timing #3	01	00000001	1		not used
2B		01	00000001	1		
2C	Standard timing #4	01	00000001	1		not used
2D		01	00000001	1		
2E	Standard timing #5	01	00000001	1		not used
2F		01	00000001	1		
30	Standard timing #6	01	00000001	1		not used
31		01	00000001	1		
32	Standard timing #7	01	00000001	1		not used
33		01	00000001	1		
34	Standard timing #8	01	00000001	1		not used
35		01	00000001	1		
36	Detailed timing/monitor descriptor #1	41	01000001	65	72.33	Main clock= 72.33 MHz
37		1C	00011100	28		
38		56	01010110	86	1366	Hor active=1366 pixels
39		A0	10100000	160	160	Hor blanking=160 pixels
3A		50	01010000	80		4bit : 4bit
3B		00	00000000	0	768	Vertical active=768 lines
3C		16	00010110	22	22	Vertical blanking=22 lines
3D		30	00110000	48		4bit : 4bit
3E		30	00110000	48	48	Hor sync. Offset=48 pixels
3F		20	00100000	32	32	H sync. Width=32 pixels
40		25	00100101	37	2 5	V sync. Offset=2 lines V sync. Width=5 lines
41		00	00000000	0		2bit : 2bit :2bit :2bit
42		58	01011000	88	344	H image size= 344 mm (approx)
43		C2	11000010	194	194	V image size = 194 mm (approx)
44		10	00010000	16		
45		00	00000000	0		No Horizontal Border
46		00	00000000	0		No Vertical Border
47	19	00011001	25			
48	Detailed timing/monitor descriptor #2	00	00000000	0		Manufacturer Specified (Timing)
49		00	00000000	0		
4A		00	00000000	0		
4B		0F	00001111	15		
4C		00	00000000	0		
4D		00	00000000	0		Value=HSPWmin / 2
4E		00	00000000	0		Value=HSPWmax / 2
4F		00	00000000	0		Value=Thbpmin / 2
50		00	00000000	0		Value=Thbpmax / 2
51		00	00000000	0		Value=VSPWmin / 2
52		00	00000000	0		Value=VSPWmax / 2
53		00	00000000	0		Value=Tvbpmin / 2
54		00	00000000	0		Value=Tvbpmax / 2
55		1E	00011110	30		Thpmin=value*2 + HA pixelClks
56		B4	10110100	180		Thpmax=value*2 + HA pixelClks
57	02	00000010	2		Tvpmn=value*2 + VA lines	
58	74	01110100	116		Tvpmx=value*2 + VA lines	
59	00	00000000	0		Module revision	

5A	Detailed timing/monitor descriptor #3	00	00000000	0		ASCII Data String Tag
5B		00	00000000	0		
5C		00	00000000	0		
5D		FE	11111110	254		
5E		00	00000000	0		
5F		53	01010011	83	[S]	
60		41	01000001	65	[A]	
61		4D	01001101	77	[M]	
62		53	01010011	83	[S]	
63		55	01010101	85	[U]	
64		4E	01001110	78	[N]	
65		47	01000111	71	[G]	
66		0A	00001010	10	[Y]	
67		20	00100000	32	[I]	
68		4C	01001100	76		supplier ID "SDC"
69	83	10000011	131			
6A	41	01000001	65	[A]	Product code "AT"	
6B	54	01010100	84	[T]	(Hex, LSB first)	
6C	Detailed timing/monitor descriptor #4	00	00000000	0		Monitor Name Tag (ASCII)
6D		00	00000000	0		
6E		00	00000000	0		
6F		FE	11111110	254		
70		00	00000000	0		
71		4C	01001100	76	[L]	
72		54	01010100	84	[T]	
73		4E	01001110	78	[N]	
74		31	00110001	49	[1]	
75		35	00110101	53	[5]	
76		36	00110110	54	[6]	
77		41	01000001	65	[A]	
78		54	01010100	84	[T]	
79		32	00110010	50	[2]	
7A		39	00111001	57	[9]	
7B	4C	01001100	76	[L]		
7C	30	00110000	48	[0]		
7D	31	00110001	49	[1]		
7E	Extension Flag	00	00000000	0		
7F	Checksum	7F	01111111	127		

12. APPENDIX

12.1 SYSTEM DESIGN GUIDE

<p>1</p>	<p>[Common]Gap in the rear of display</p> <p>Prevent the product from being defected resulted from the interference and the lack of gap between the rear cover of system and the LCD module.</p>
<p>Recommendation</p>	<p>A. The gap between the rear cover of system and the rear of LCD module : Min. 1.0mm</p> <p>B. Based on the size of part in a maximum size between the rear cover of system and the LCD module. : Min. 1.0mm</p> <p>(※ Based on the maximum thickness of module, which the tolerance is considered.)</p>
<p>Risk factor</p>	<p>Pooling / White Spot / Being divided</p>
<p>2</p>	<p>[Common] The shape of key pad of system</p> <p>Prevent the product from being defected resulted from the shape of key pad in the system.</p>
<p>Recommendation</p>	<p>A. Make the shape of frame, which surrounds the key pad as round as possible.</p> <p>B. Prevent the product from being defected resulted from the pressurization by attaching the sponge on the cover of system not to be overlapped with the position of the frame around key pad.</p> <p>C. Prevent the product from being defected, which is resulted from the pressurization from outside by eliminating the difference in height between the key pad and the frame around key pad.</p>
<p>Risk factor</p>	<p>White Spot / Black Spot / Being broken in glass.</p>

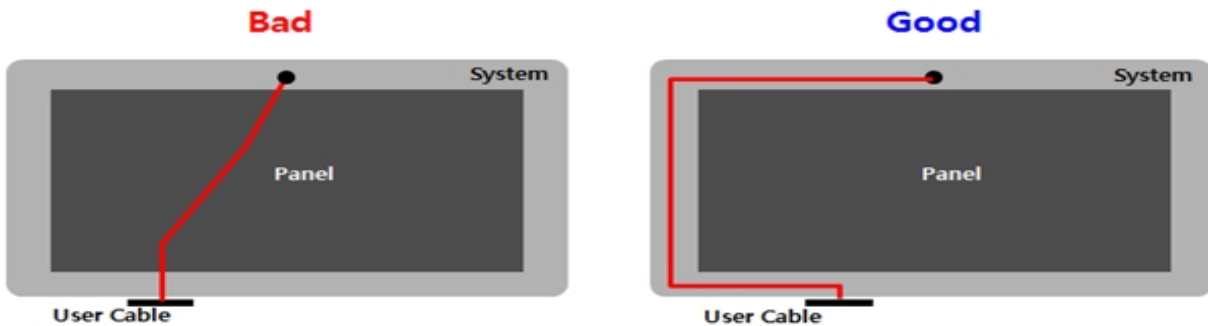
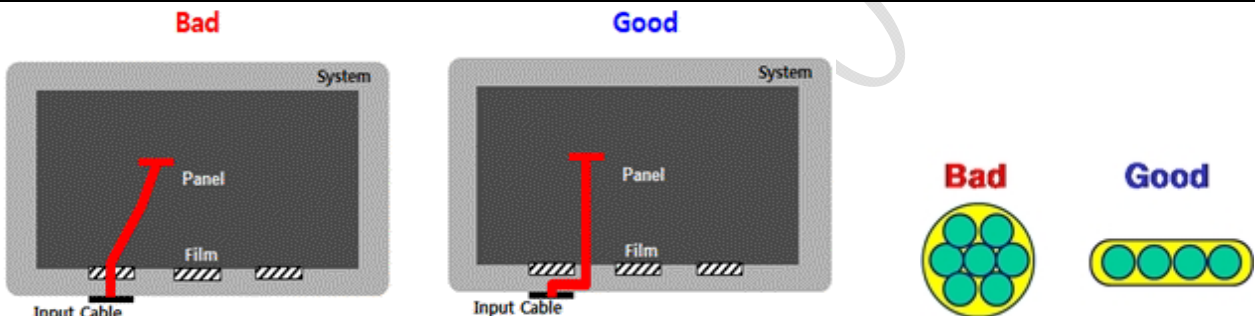
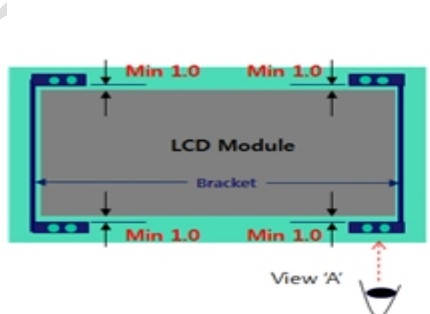
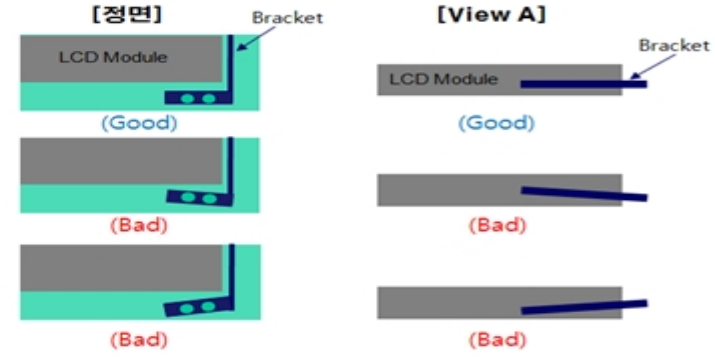
3	<p>[Common] The arrangement of user cable (Camera, Antenna)</p> <p>Prevent the product from being defected resulted from the user cable arranged on the rear of module.</p>
	
Recommendation	A. Arrange the user cable in the side not in the rear(the active area) of LCD module.
Risk factor	Pooling / White Spot
4	<p>[Common] The arrangement of input cable</p> <p>Prevent the product from being defected resulted from the overlapping between the input cable and the film of LCD module .</p>
	
Recommendation	<p>A. Arrange the input cable not to be overlapped with the COF film.</p> <p>B. Minimization of the height of input cable and making the COF film flat.</p>
Risk factor	A/D (The damaged COF film is cracked., The chip is broken.)
5	<p>[ELS] Gap between the bracket and the LCD Module</p> <p>Prevent the LCD module from being interfered when testing the product in terms of the performance of hinge and the occurrence of twist.</p>
	
Recommendation	<p>A. Secure the min. 1.0mm distance between the bracket and the LCD module at 4 corners of screen respectively.</p> <p>B. Control the angle of bracket on the system.</p>

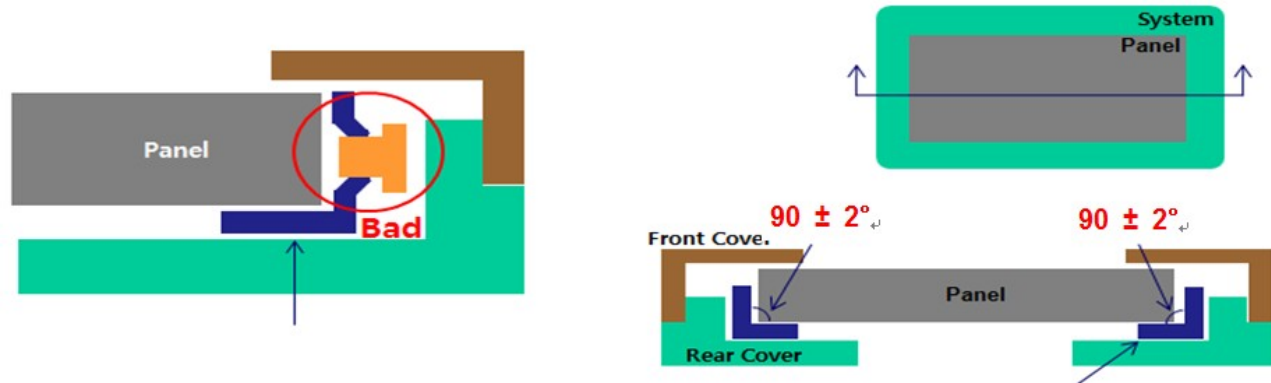
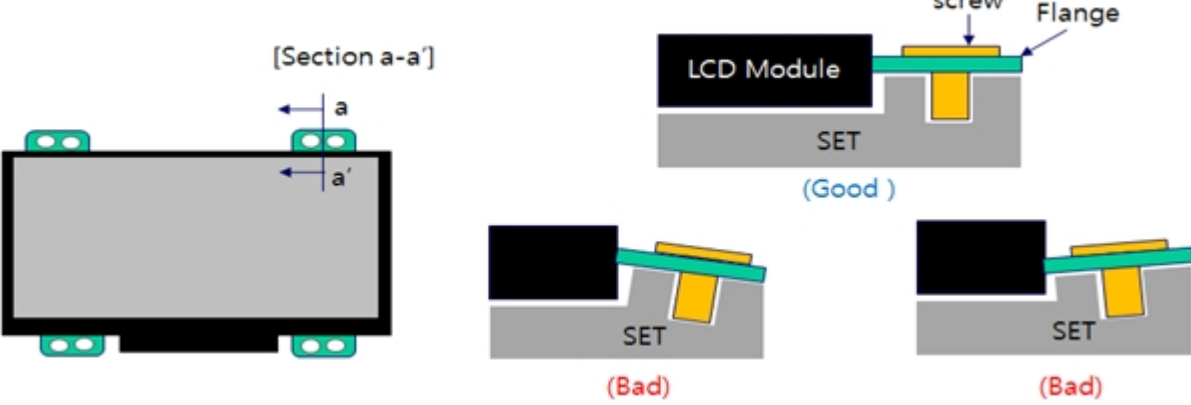
6	<p>[ELS] Suggestion on the angle of bracket</p> <p>Prevent the product from being defected resulted from the changed top chassis by the angle and the shape of bracket on the system.</p>
	
Recommendation	<p>A. Don't form the bracket hole.</p> <p>B. Control the angle in the event that the bracket, which has L-shape is applied. ($90 \pm 2^\circ$)</p>
Risk factor	Pooling / Light leakage
7	<p>[UMS] Control the angle of the connected part on the user flange</p> <p>Prevent the user flange from not being placed horizontally, which is caused when the LCD module, which is structured in UMS is assembled.</p>
	
Recommendation	<p>A. Prevent the product from being pooled resulted from the changed user flange created when assembling the LCD module to the system.</p> <p>B. Insert the screw to the hole of flange vertically when LCD module is assembled to the system.</p>
Risk factor	Pooling