



TO : Lenovo  
DATE : June 17, 2008

**SAMSUNG TFT-LCD**  
**MODEL NO. : LTN170BT09-001**

**NOTE** : Extension code [ -0 ]  
→ LTN170BT09-0  
Surface type [**Anti-Glare** ]

Any Modification of Spec is not allowed without SEC' permission

APPROVED BY : *K. H. Shin*

PREPARED BY : Mobile Division, Application Engineering Part

**SAMSUNG ELECTRONICS CO., LTD.**



**Samsung Secret**

Doc.No.	LTN170BT09-001	Rev.No	04-A00-S-080617	Page	1 / 33
---------	----------------	--------	-----------------	------	--------

## CONTENTS

Revision History	----- ( 3 )
General Description	----- ( 4 )
1. Absolute Maximum Ratings	----- ( 5 )
1.1 Absolute Ratings of environment	
1.2 Electrical Absolute Ratings	
2. Optical Characteristics	----- ( 7 )
3. Electrical Characteristics	----- ( 11 )
3.1 TFT LCD Module	
3.2 Backlight Unit	
4. Block Diagram	----- ( 14 )
4.1 TFT LCD Module	
4.2 Backlight Unit	
5. Input Terminal Pin Assignment	----- ( 15 )
5.1 Input Signal & Power	
5.2 LVDS Interface	
5.3 Backlight Unit	
5.4 Timing Diagrams of LVDS For Transmitting	
5.5 Input Signals, Basic Display Colors and Gray Scale of Each Color.	
5.6 Pixel format	
6. Interface Timing	----- ( 21 )
6.1 Timing Parameters	
6.2 Timing Diagrams of interface Signal	
6.3 Power ON/OFF Sequence	
7. Outline Dimension	----- ( 23 )
8. Packing	----- ( 25 )
9. Markings & Others	----- ( 27 )
10. General Precaution	----- ( 29 )
11. EDID	----- ( 31 )

**Samsung Secret**

# REVISION HISTORY

Preliminary

Date	Revision No.	Page	Summary
May. 17, 2008	P00	All	- Preliminary spec of LTN170BT09-001 was issued first.
May. 20, 2008	P01	p. 5	- Weight spec was changed as below. [AS-IS] Typ. 670g, Max. 700g [TO-BE] Typ. 630g, Max 650g
June. 17, 2008	A00	All  p.31-33	-Approval specification of LTN170BT09-001 was issued.  -EDID was changed by customer's request. [AS-IS] checksum 'AA' → [TO-BE] 'B0'

Samsung Secret

## GENERAL DESCRIPTION

### DESCRIPTION

LTN170BT09-001 is a color active matrix TFT (Thin Film Transistor) liquid crystal display (LCD) that uses amorphous silicon TFT as switching devices. This model is composed of a TFT LCD panel, a driver circuit and a backlight unit. The resolution of a 17.0" contains 1,440 x 900 pixels and can display up to 262,144 colors. 6 O'clock direction is the Optimum viewing angle.

### FEATURES

- High contrast ratio, high aperture structure
- Wide XGA+(1440 x 900 pixels) resolution
- Low power consumption
- Fast Response
- DE(Data enable) only mode
- 3.3V LVDS Interface
- Onboard EEDID chip
- Pb free product

### APPLICATIONS

- Notebook PC
- If the usage of this product is not for PC application, but for others, please contact SEC

## GENERAL INFORMATION

Item	Specification	Unit	Note
Display area	367.20(H) x 229.50(V) (17.0" diagonal )	mm	
Driver element	a-Si TFT active matrix		
Display colors	262,144		
Number of pixel	1440 x 900 (Wide XGA+)	pixel	16 : 10
Pixel arrangement	RGB vertical stripe		
Pixel pitch	0.255(H) x 0.255(V) (TYP.)	mm	99.6ppi
Display Mode	Normally white		
Surface treatment	Haze 25 ( Anti-Glare ), Hardness 3H		

**Samsung Secret**

<b>Doc.No.</b>	LTN170BT09-001	<b>Rev.No</b>	04-A00-S-080617	<b>Page</b>	4 / 33
----------------	----------------	---------------	-----------------	-------------	--------

### Mechanical Information

Item		Min.	Typ.	Max.	Unit	Note
Module size	Horizontal (H)	381.7	382.2	382.7	mm	
	Vertical (V)	224.0	244.5	245.0	mm	
	Depth (D)	-	6.7	7.0	mm	
Weight		-	630	650	g	

Note (1) Measurement condition of outline dimension  
 . Equipment : Vernier Calipers  
 . Push Force : 500g · f (minimum)

## 1. ABSOLUTE MAXIMUM RATINGS

### 1.1 ENVIRONMENTAL ABSOLUTE RATINGS

Item	Symbol	Min.	Max.	Unit	Note
Storage temperate	TSTG	-20	60	°C	(1),(5)
Operating temperate (Temperature of glass surface)	TOPR	0	50	°C	(1),(5)
Shock ( non-operating )	Snop	-	240	G	(2),(4)
Vibration (non-operating)	Vnop	-	2.41	G	(3),(4)

Note (1) Temperature and relative humidity range are shown in the figure below.  
 95 % RH Max. (40 °C ≥ Ta)  
 Maximum wet - bulb temperature at 39 °C or less. (Ta > 40 °C ) No condensation

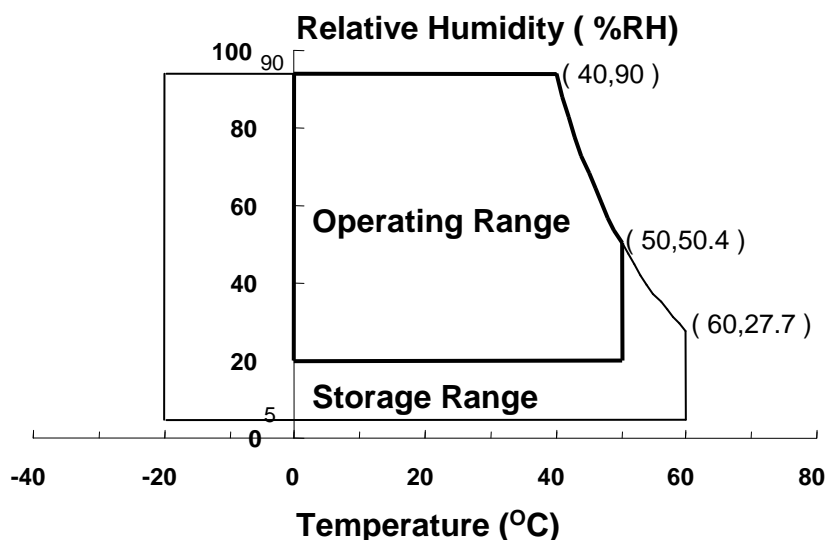

- (2) 2ms, half sine wave, one time for ±X, ±Y, ±Z.
- (3) 5 - 500 Hz, random vibration, 30min for X, Y, Z.
- (4) At testing Vibration and Shock, the fixture in holding the Module to be tested have to be hard and rigid enough so that the Module would not be twisted or bent by the fixture.
- (5) If product is used for extended time excessively or exposed to high temperatures for extended time, there is a possibility of wide viewing angle film damage which could affect visual characteristics.

**Samsung Secret**

## 1.2 ELECTRICAL ABSOLUTE RATINGS

## (1) TFT LCD MODULE

 $V_{DD} = 3.3V, V_{SS} = GND = 0V$ 

Item	Symbol	Min.	Max.	Unit	Note
Power Supply Voltage	$V_{DD}$	$V_{DD} - 0.3$	$V_{DD} + 0.3$	V	(1)
Logic Input Voltage	$V_{IN}$	$V_{DD} - 0.3$	$V_{DD} + 0.3$	V	(1)

Note (1) Within  $T_a$  ( $25 \pm 2 \text{ }^\circ\text{C}$ )

## (2) BACK-LIGHT UNIT

 $T_a = 25 \pm 2 \text{ }^\circ\text{C}$ 

Item	Symbol	Min.	Max.	Unit	Note
Lamp Current	$I_L$	3.0	7.0	mArms	(1)
Lamp frequency	$F_L$	50	70	kHz	(1)

Note 1) Permanent damage to the device may occur if maximum values are exceeded  
 Functional operation should be restricted to the conditions described under normal operating conditions.

Samsung Secret

## 2. OPTICAL CHARACTERISTICS

The following items are measured under stable conditions. The optical characteristics should be measured in a dark room or equivalent state with the methods shown in Note (5).  
Measuring equipment : TOPCON SR-3

\* Ta = 25 ± 2 °C, VDD=3.3V, fv= 60Hz, fdCLK = 48.89MHz, IL = 6.0 mA

Item		Symbol	Condition	Min.	Typ.	Max	Unit	Note
Contrast Ratio (5 Points)		CR	Normal Viewing Angle $\phi = 0$ $\theta = 0$	300	500	-	-	(1), (2), (5)
Response Time at Ta ( Rising + Falling )		T <sub>RT</sub>		-	16	25	msec	(1), (3)
Average Luminance of White (5 Points)		Y <sub>L,AVE</sub>		170	200	-	cd/m <sup>2</sup>	IL=6.0mA (1), (4)
Color Chromaticity ( CIE )	Red	R <sub>X</sub>		0.558	0.588	0.618	-	(1), (5) SR-3
		R <sub>Y</sub>		0.310	0.340	0.370		
	Green	G <sub>X</sub>		0.300	0.330	0.360		
		G <sub>Y</sub>		0.507	0.537	0.567		
	Blue	B <sub>X</sub>		0.121	0.151	0.181		
		B <sub>Y</sub>		0.092	0.122	0.152		
	White	W <sub>X</sub>		0.283	0.313	0.343		
		W <sub>Y</sub>	0.299	0.329	0.359			
Viewing Angle	Hor.	$\theta_L$	-	45	-	Degrees	(1), (5) SR-3	
		$\theta_H$	-	45	-			
	Ver.	$\phi_H$	-	20	-			
		$\phi_L$	-	40	-			
13 Points White Variation		$\delta_L$	65%	-	-	-	(6)	
5 Points White Variation		$\delta_L$	80%	-	-	-	(7)	

**Samsung Secret**

Note 1) Definition of Viewing Angle : Viewing angle range ( $10 \leq C/Rat$  center point)

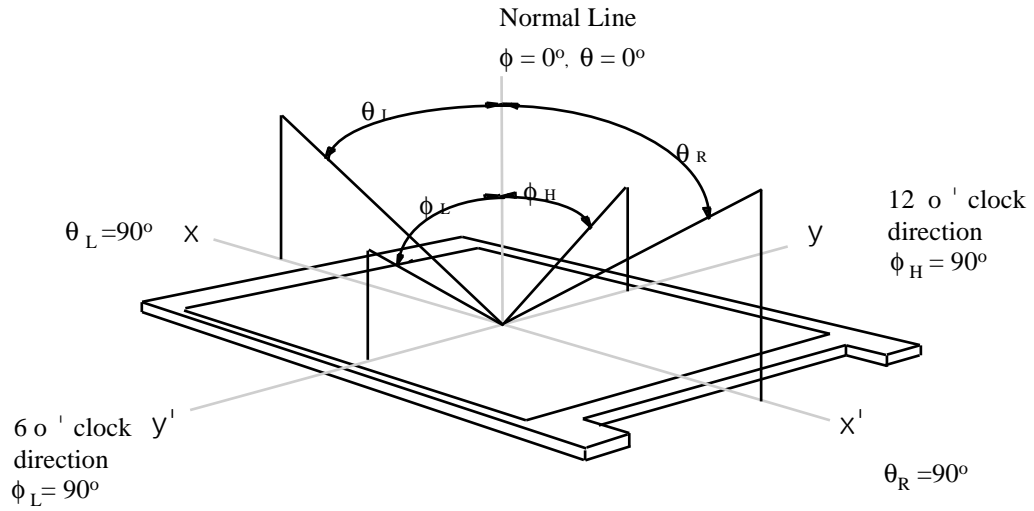

Note 2) Definition of Contrast Ratio (CR) : Ratio of gray max (Gmax), gray min (Gmin) at 5 points(4, 5, 7, 9, 10)

$$CR = \frac{CR(4) + CR(5) + CR(7) + CR(9) + CR(10)}{5}$$

POINTS : (4), (5), (7), (9), (10) at FIGURE OF NOTE 6)

Note 3) Definition of Response time : Sum of  $T_R, T_F$

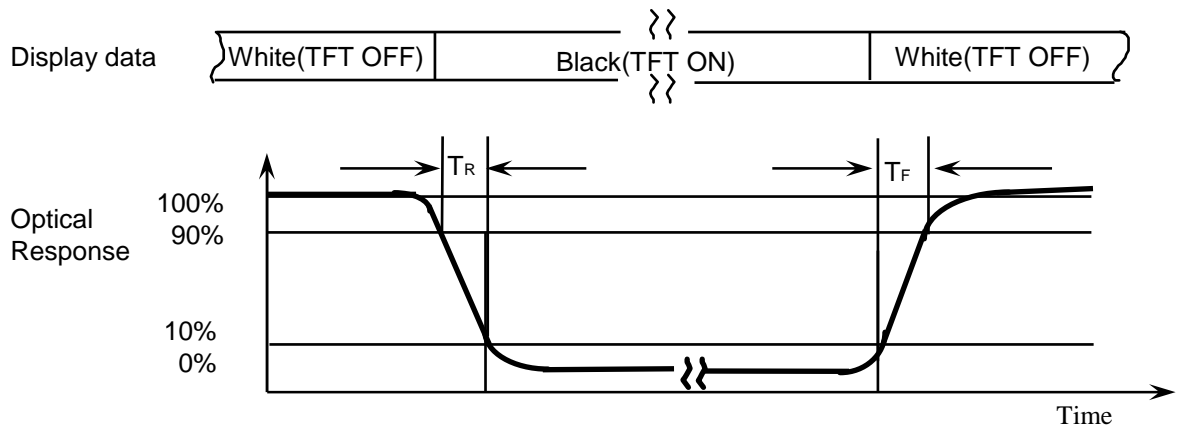

**Samsung Secret**



Note 4) Definition of Luminance of White : measure the luminance of white at 5 points.

Average Luminance of White (  $Y_{L,AVE}$  )

$$Y_{L,AVE} = \frac{Y_{L4} + Y_{L5} + Y_{L7} + Y_{L9} + Y_{L10}}{5}$$

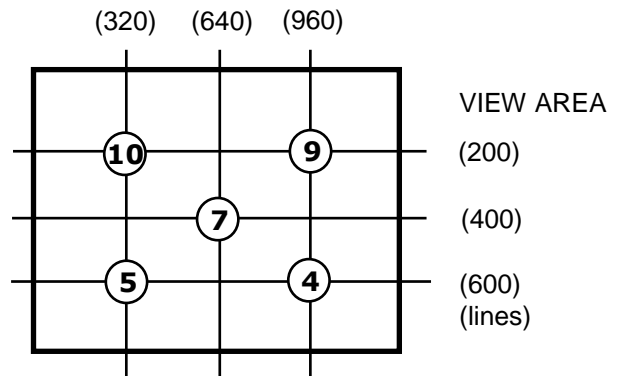

Note 5) After stabilizing and leaving the panel alone at a given temperature for 30 min , the measurement should be executed. Measurement should be executed in a stable, windless, and dark room. 30 min after lighting the back-light. This should be measured in the center of screen.  
 Lamp current : 6.0mA  
 Environment condition :  $T_a = 25^{\circ}\text{C} \pm 2^{\circ}\text{C}$

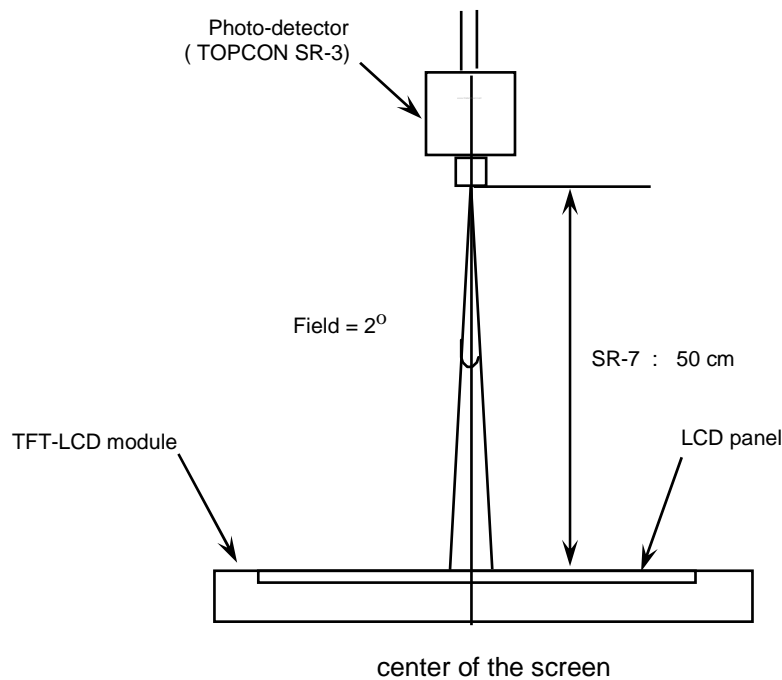

Optical characteristics measurement setup

**Samsung Secret**

Note 6) Definition of 13 points white variation, CR variation(  $C_{VER}$  ) [ ① ~ ⑬ ]

$$\text{13 points white variation (\%)} = \frac{\text{Minimum luminance of 13 points}}{\text{Maximum luminance of 13 points}} \times 100$$

Meet ISO13406-2 Luminance uniformity

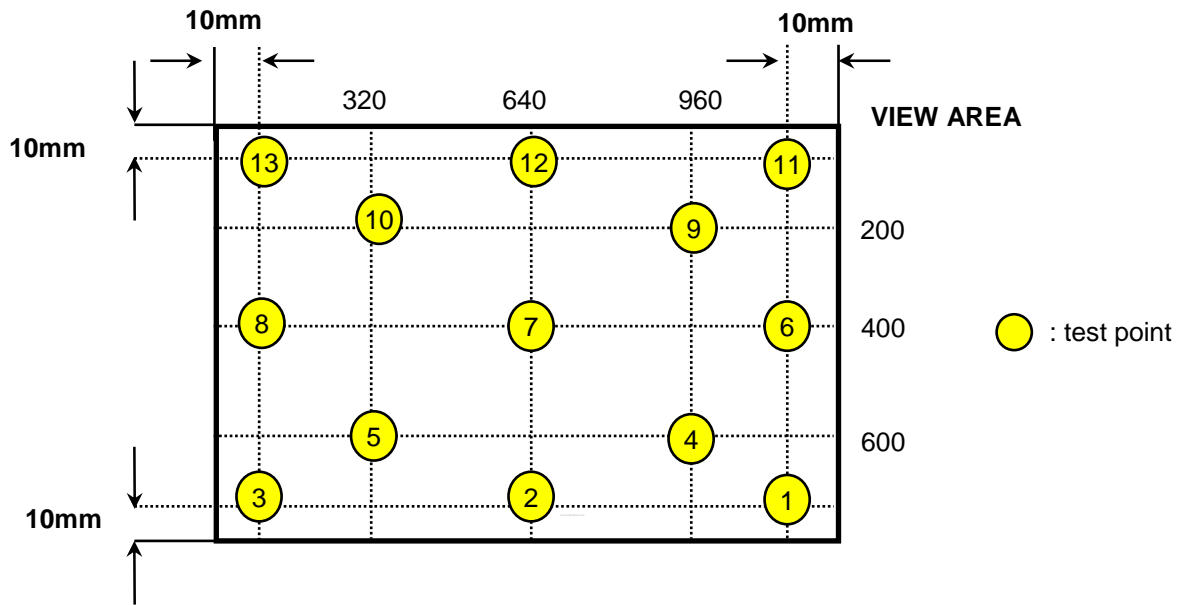

Note 7) Definition of 5 points white variation, CR variation(  $C_{VER}$  ) [ 4,5,7,9,10 ]

$$\text{5 points white variation (\%)} = \frac{\text{Minimum luminance of 5 points}}{\text{Maximum luminance of 5 points}} \times 100$$

### 3. ELECTRICAL CHARACTERISTICS

#### 3.1 TFT LCD MODULE

Ta= 25 ± 2°C

Item	Symbol	Min.	Typ.	Max.	Unit	Note	
Voltage of Power Supply	V <sub>DD</sub>	3.0	3.3	3.6	V		
Differential Input Voltage for LVDS Receiver Threshold	High	V <sub>IH</sub>	-	-	+100	mV	V <sub>CM</sub> = +1.2V
	Low	V <sub>IL</sub>	-100	-	-	mV	
Vsync Frequency	f <sub>v</sub>	-	60	-	Hz		
Hsync Frequency	f <sub>H</sub>	-	55.56	-	KHz		
Main Frequency	f <sub>DCLK</sub>	-	48.89	-	MHz		
Rush Current	I <sub>RUSH</sub>	-	-	1.5	A	(4)	
Current of Power Supply	White	I <sub>DD</sub>	-	710	-	mA	(2),(3)*a
	Mosaic		-	740	-	mA	(2),(3)*b
	V. stripe		-	830	900	mA	(2),(3)*c

Note (1) Display data pins and timing signal pins should be connected.( GND = 0V )

(2) f<sub>v</sub> = 60Hz, f<sub>DCLK</sub> = 48.89MHz, V<sub>DD</sub> = 3.3V , DC Current.

(3) Power dissipation pattern

\*a) White Pattern

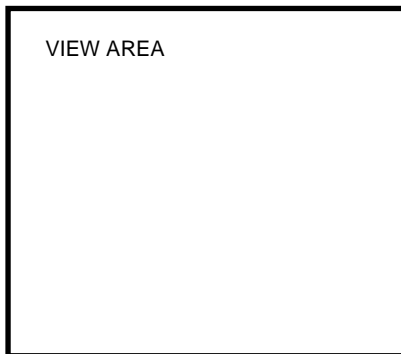

\*b) Mosaic Pattern

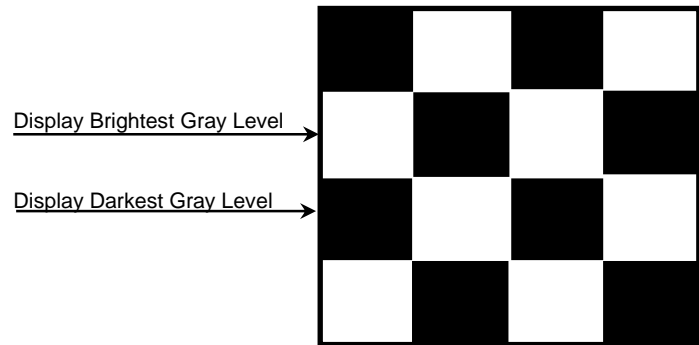

**Samsung Secret**

\*c) 1dot Vertical stripe pattern

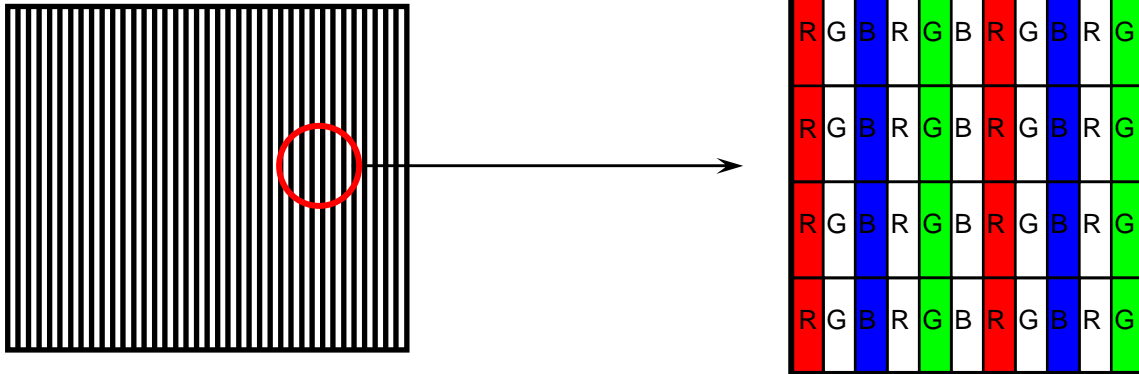

4) Rush current measurement condition

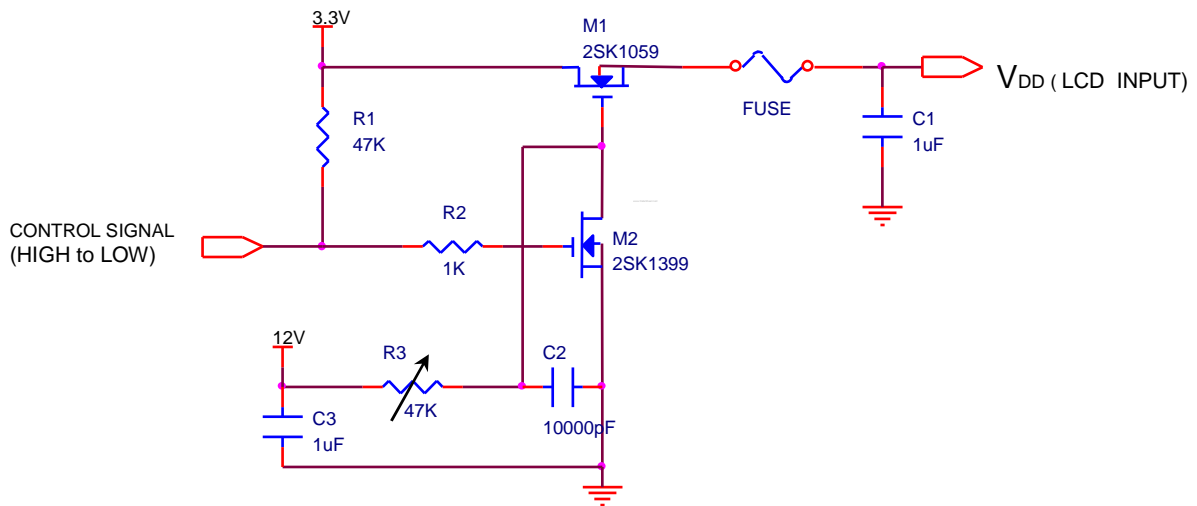

$V_{DD}$  rising time is 470us

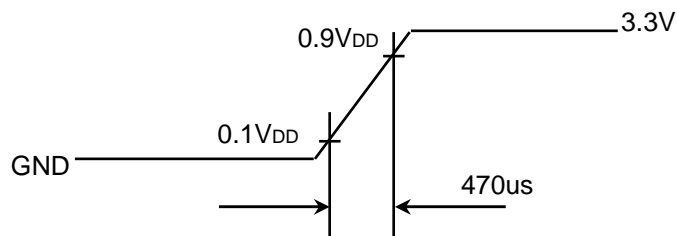

**Samsung Secret**

### 3.2 BACK-LIGHT UNIT

The backlight system is an edge-lighting type with a single CCFT ( Cold Cathode Fluorescent Tube ).  
The characteristics of a single lamp are shown in the following table.

- INVERTER : SEM SIC 130T

Ta= 25 ± 2 °C

Item	Symbol	Min.	Typ.	Max.	Unit	Note
Lamp Current	I <sub>L</sub>	3.0	6.0	6.5	mArms	(1)
Lamp Voltage	V <sub>L</sub>	-	720	-	Vrms	I <sub>L</sub> = 6.0mA
Frequency	f <sub>L</sub>	50	60	65	KHz	(2)
Power Consumption	P <sub>L</sub>		4.32		W	(3) I <sub>L</sub> = 6.0mA
Operating Life Time	Hr	10,000	-	-	Hour	(4)
Startup Voltage	V <sub>s</sub>			1,280	Vrms	25°C, (5)
				1,600	Vrms	0°C, (5)

**Note) The waveform of the inverter output voltage must be area symmetric and the design of the inverter must have specifications for the modularized lamp.**

The performance of the backlight, for example life time or brightness, is much influenced by the characteristics of the DC-AC inverter for the lamp. So all the parameters of an inverter should be carefully designed so as not to produce too much leakage current from high-voltage output of the inverter. When you design or order the inverter, please make sure that a poor lighting caused by the mismatch of the backlight and the inverter(miss lighting, flicker, etc.) never occur. When you confirm it, the module should be operated in the same condition as it is installed in your instrument.

Note (1) Lamp current is measured with a high frequency current meter as shown below.

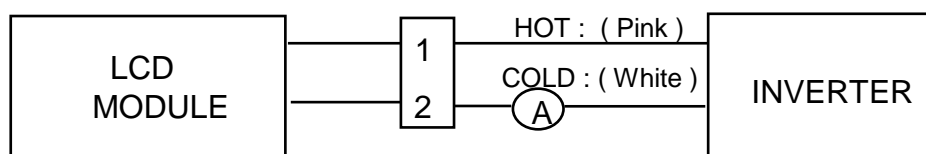

(2) Lamp frequency may produce interference with horizontal synchronous frequency and this may cause line flow on the display. Therefore lamp frequency should be detached from the horizontal synchronous frequency and its harmonics as far as possible in order to avoid interference.

(3) Refer to I<sub>L</sub> × V<sub>L</sub> to calculate.

(4) Life time (Hr) of a lamp can be defined as the time in which it continues to operate under the condition Ta= 25 ± 2 °C and I<sub>L</sub> = 6.0 mArms until one of the following event occurs.

1. When the brightness becomes 50% or lower than the original.
2. When the Effective ignition length becomes 80% or lower than the original value.  
(Effective ignition length is defined as an area that has less than 70% brightness compared to the brightness in the center point.)

(5) The inverter open voltage - this voltage should be measured after ballast capacitor- have to be larger than the lamp startup voltage, otherwise backlight may has blinking for a moment after turns on or not be turned on.

If an inverter has shutdown function it should keep its open voltage for longer than 1 second even if lamp connector open.

**Samsung Secret**

## 4. BLOCK DIAGRAM

### 4.1 TFT LCD Module

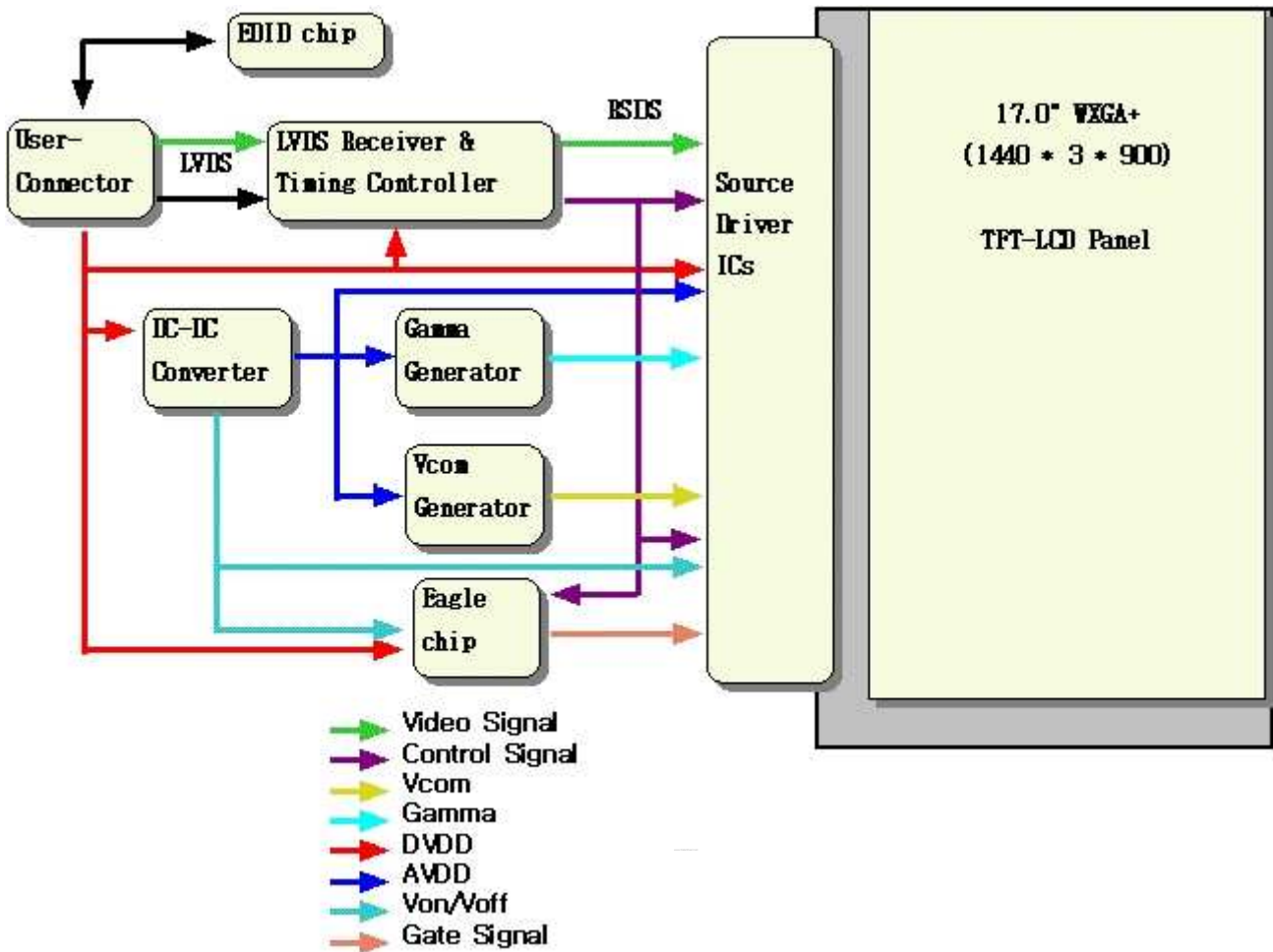

### 4.2 BACKLIGHT UNIT

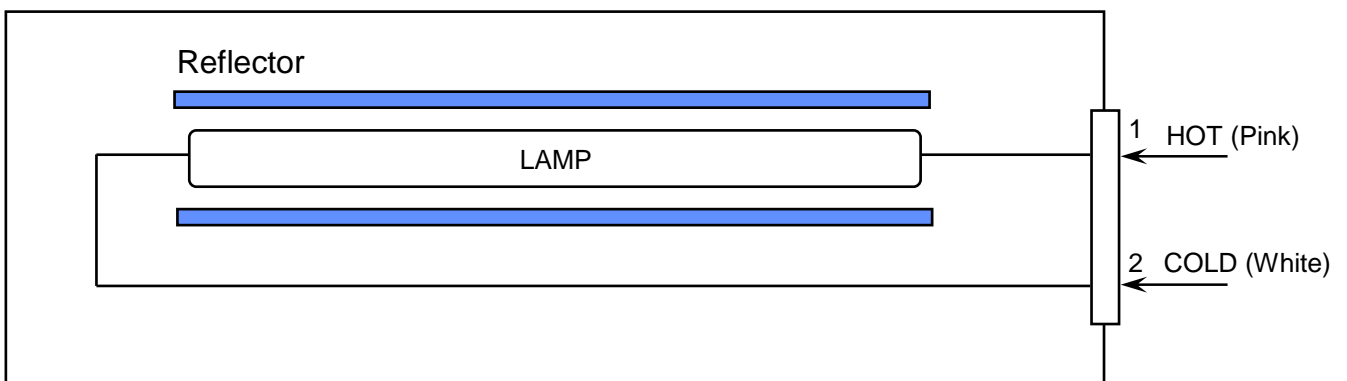

Note) The output of the inverter may change according to the material of the reflector.

**Samsung Secret**

## 5. INPUT TERMINAL PIN ASSIGNMENT

### 5.1. Input Signal & Power (LVDS, Connector : JAE FI-XB30SRLZ-HF11 ) Mating Connector : JAE FI-X30M or compatible)

No.	Symbol	Function	Polarity	Remarks
1	VSS	Ground		
2	VDD	POWER SUPPLY +3.3V		
3	VDD	POWER SUPPLY +3.3V		
4	VEEDID	DDC 3.3V Power		
5	NC	No connection		
6	CLKEDID	DDC Clock		
7	DATAEDID	DDC data		
8	O_RxIN0-	LVDS Differential Data INPUT (Odd R0-R5,G0)	Negative	
9	O_RxIN0+	LVDS Differential Data INPUT (Odd R0-R5,G0)	Positive	
10	GND	Ground		
11	O_RxIN1-	LVDS Differential Data INPUT (Odd G1-G5,B0-B1)	Negative	
12	O_RxIN1+	LVDS Differential Data INPUT (Odd G1-G5,B0-B1)	Positive	
13	GND	Ground		
14	O_RxIN2-	LVDS Differential Data INPUT (Odd B2-B5,Sync,DE)	Negative	
15	O_RxIN2+	LVDS Differential Data INPUT (Odd B2-B5,Sync,DE)	Positive	
16	GND	Ground		
17	O_RxCLK-	LVDS Differential Data INPUT (Odd Clock)	Negative	
18	O_RxCLK+	LVDS Differential Data INPUT (Odd Clock)	Positive	
19	GND	Ground		
20	E_RxIN0-	LVDS Differential Data INPUT (Even R0-R5,G0)	Negative	
21	E_RxIN0+	LVDS Differential Data INPUT (Even R0-R5,G0)	Positive	
22	GND	Ground		
23	E_RxIN1-	LVDS Differential Data INPUT (Even G1-G5,B0-B1)	Negative	
24	E_RxIN1+	LVDS Differential Data INPUT (Even G1-G5,B0-B1)	Positive	
25	GND	Ground		
26	E_RxIN2-	LVDS Differential Data INPUT (Even B2-B5,Sync,DE)	Negative	
27	E_RxIN2+	LVDS Differential Data INPUT (Even B2-B5,Sync,DE)	Positive	
28	GND	Ground		
29	E_RxCLK-	LVDS Differential Data INPUT (Even Clock)	Negative	
30	E_RxCLK+	LVDS Differential Data INPUT (Even Clock)	Positive	

**Samsung Secret**

## 5.2 LVDS Interface : Transmitter DS90CF363 or Compatible

## LVDS for Odd pixel

Pin No.	Name	RGB Signal	Pin No.	Name	RGB Signal
44	TxIN0	RO0	12	TxIN11	GO5
45	TxIN1	RO1	13	TxIN12	BO0
47	TxIN2	RO2	15	TxIN13	BO1
48	TxIN3	RO3	16	TxIN14	BO2
1	TxIN4	RO4	18	TxIN15	BO3
3	TxIN5	RO5	19	TxIN16	BO4
4	TxIN6	GO0	20	TxIN17	BO5
6	TxIN7	GO1	22	TxIN18	Hsync
7	TxIN8	GO2	23	TxIN19	Vsync
9	TxIN9	GO3	25	TxIN20	DE
10	TxIN10	GO4	26	TxCLK IN	Clock

## LVDS for Even pixel

Pin No.	Name	RGB Signal	Pin No.	Name	RGB Signal
44	TxIN0	RE0	12	TxIN11	GE5
45	TxIN1	RE1	13	TxIN12	BE0
47	TxIN2	RE2	15	TxIN13	BE1
48	TxIN3	RE3	16	TxIN14	BE2
1	TxIN4	RE4	18	TxIN15	BE3
3	TxIN5	RE5	19	TxIN16	BE4
4	TxIN6	GE0	20	TxIN17	BE5
6	TxIN7	GE1	22	TxIN18	N/C
7	TxIN8	GE2	23	TxIN19	N/C
9	TxIN9	GE3	25	TxIN20	N/C
10	TxIN10	GE4	26	TxCLK IN	Clock

Samsung Secret



### LVDS Interface

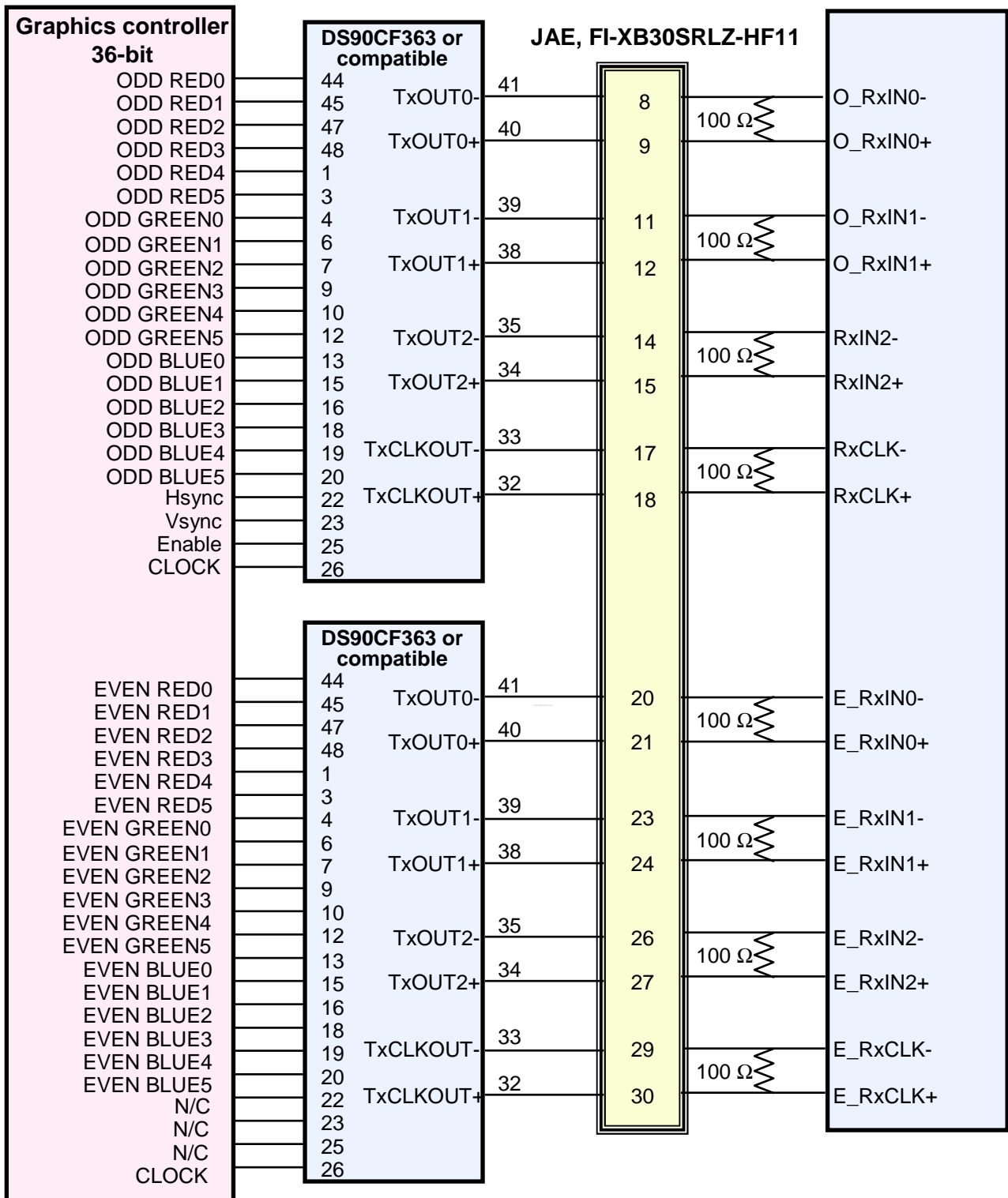

Note : The LCD Module uses a 100ohm resistor between positive and negative lines of each receiver input.

**Samsung Secret**

### 5.3 BACK LIGHT UNIT

Preliminary

Connector : JST BHSR - 02VS -1  
Mating Connector : SM02B-BHSS-1(JST)

Pin NO.	Symbol	Color	Function
1	HOT	Pink	High Voltage
2	COLD	White	Low Voltage

### 5.4 Timing Diagrams of LVDS For Transmission

LVDS Receiver : Integrated T-CON

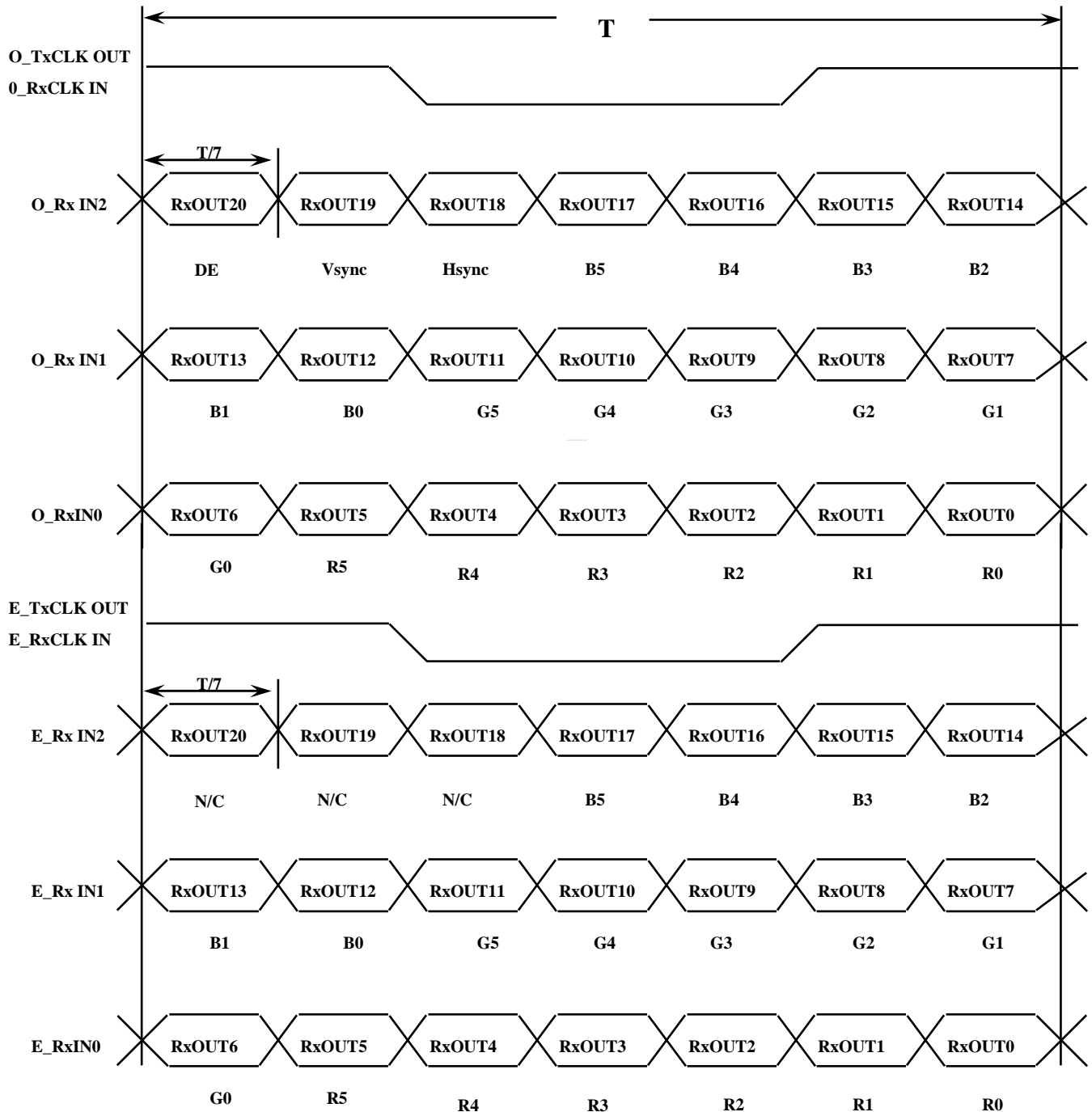

**Samsung Secret**

### 5.5 Input Signals, Basic Display Colors and Gray Scale of Each Color

Color	Display	Data Signal																Gray Scale Level	
		Red					Green					Blue							
		R0	R1	R2	R3	R4	R5	G0	G1	G2	G3	G4	G5	B0	B1	B2	B3		45
Basic Colors	Black	0	0	0	0	0	0	0	0	0	0	0	0	0	0	0	0	0	-
	Blue	0	0	0	0	0	0	0	0	0	0	0	0	1	1	1	1	1	-
	Green	0	0	0	0	0	0	1	1	1	1	1	1	0	0	0	0	0	-
	Cyan	0	0	0	0	0	0	1	1	1	1	1	1	1	1	1	1	1	-
	Red	1	1	1	1	1	1	0	0	0	0	0	0	0	0	0	0	0	-
	Magenta	1	1	1	1	1	1	0	0	0	0	0	0	1	1	1	1	1	-
	Yellow	1	1	1	1	1	1	1	1	1	1	1	1	0	0	0	0	0	-
	White	1	1	1	1	1	1	1	1	1	1	1	1	1	1	1	1	1	-
Gray Scale Of Red	Black	0	0	0	0	0	0	0	0	0	0	0	0	0	0	0	0	0	R0
	Dark	1	0	0	0	0	0	0	0	0	0	0	0	0	0	0	0	0	R1
	↑	0	1	0	0	0	0	0	0	0	0	0	0	0	0	0	0	0	R3~R60
	:	:	:	:	:	:	:	:	:	:	:	:	:	:	:	:	:	:	
	:	:	:	:	:	:	:	:	:	:	:	:	:	:	:	:	:	:	
	↓	1	0	1	1	1	1	0	0	0	0	0	0	0	0	0	0	0	R61
	Light	0	1	1	1	1	1	0	0	0	0	0	0	0	0	0	0	0	R62
	Red	1	1	1	1	1	1	0	0	0	0	0	0	0	0	0	0	0	R63
Gray Scale Of Green	Black	0	0	0	0	0	0	0	0	0	0	0	0	0	0	0	0	0	G0
	Dark	0	0	0	0	0	0	1	0	0	0	0	0	0	0	0	0	0	G1
	↑	0	0	0	0	0	0	0	1	0	0	0	0	0	0	0	0	0	G3~G60
	:	:	:	:	:	:	:	:	:	:	:	:	:	:	:	:	:	:	
	:	:	:	:	:	:	:	:	:	:	:	:	:	:	:	:	:	:	
	↓	0	0	0	0	0	0	1	0	1	1	1	1	0	0	0	0	0	G61
	Light	0	0	0	0	0	0	0	1	1	1	1	1	0	0	0	0	0	G62
	Green	0	0	0	0	0	0	1	1	1	1	1	1	0	0	0	0	0	G63
Gray Scale Of Blue	Black	0	0	0	0	0	0	0	0	0	0	0	0	0	0	0	0	0	B0
	Dark	0	0	0	0	0	0	0	0	0	0	0	0	1	0	0	0	0	B1
	↑	0	0	0	0	0	0	0	0	0	0	0	0	0	1	0	0	0	B3~B60
	:	:	:	:	:	:	:	:	:	:	:	:	:	:	:	:	:	:	
	:	:	:	:	:	:	:	:	:	:	:	:	:	:	:	:	:	:	
	↓	0	0	0	0	0	0	0	0	0	0	0	0	1	0	1	1	1	B61
	Light	0	0	0	0	0	0	0	0	0	0	0	0	0	1	1	1	1	B62
	Blue	0	0	0	0	0	0	0	0	0	0	0	0	1	1	1	1	1	B63

Note 1) Definition of gray :

Rn: Red gray, Gn: Green gray, Bn: Blue gray (n=gray level)

Note 2) Input signal: 0 =Low level voltage, 1=High level voltage

**Samsung Secret**

### 5.6 Pixel Format in the display

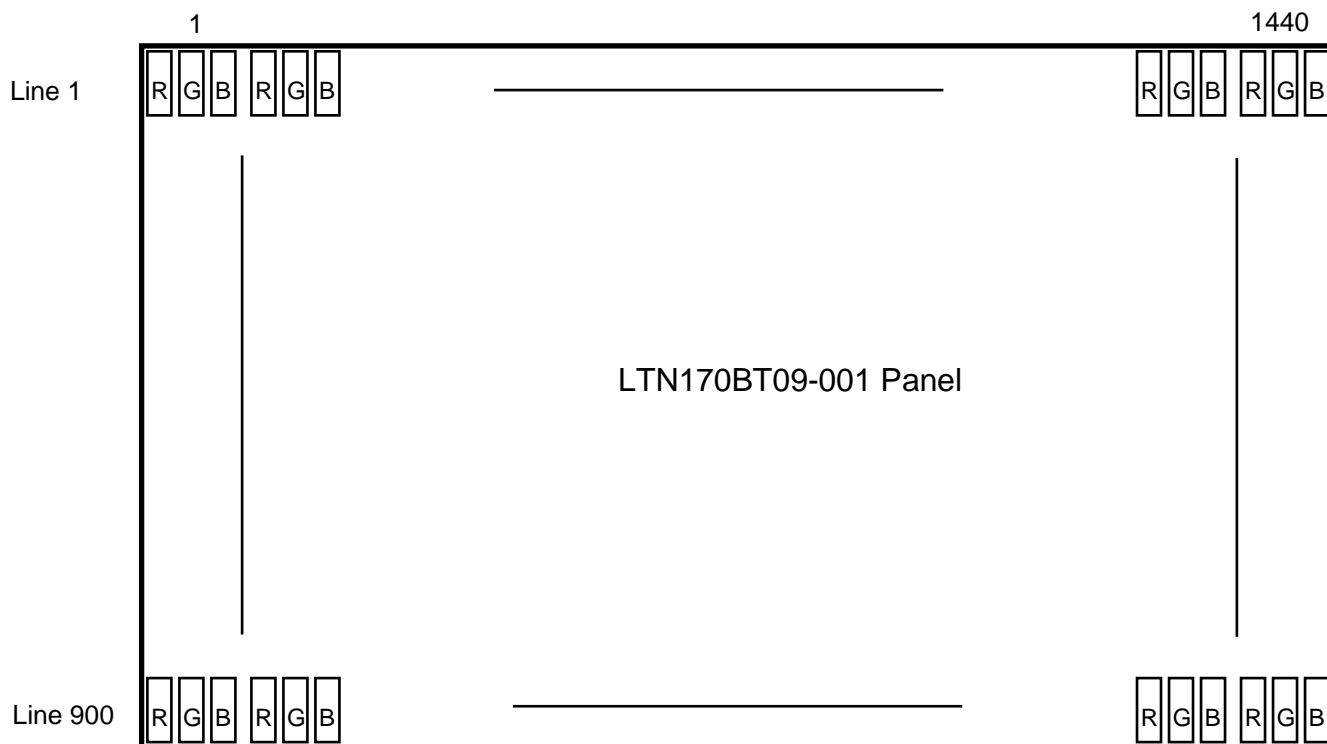

**Samsung Secret**

## 6. INTERFACE TIMING

### 6.1 Timing Parameters

Signal	Item	Symbol	Min.	Typ.	Max.	Unit	Note
Frame Frequency	Cycle	TV	905	912	970	Lines	
Vertical Active Display Term	Display Period	TV <sub>D</sub>	-	900	-	Lines	
One Line Scanning Time	Cycle	TH	876	880	950	Clocks	
Horizontal Active Display Term	Display Period	TH <sub>D</sub>	-	720	-	Clocks	

### 6.2 Timing diagrams of interface signal

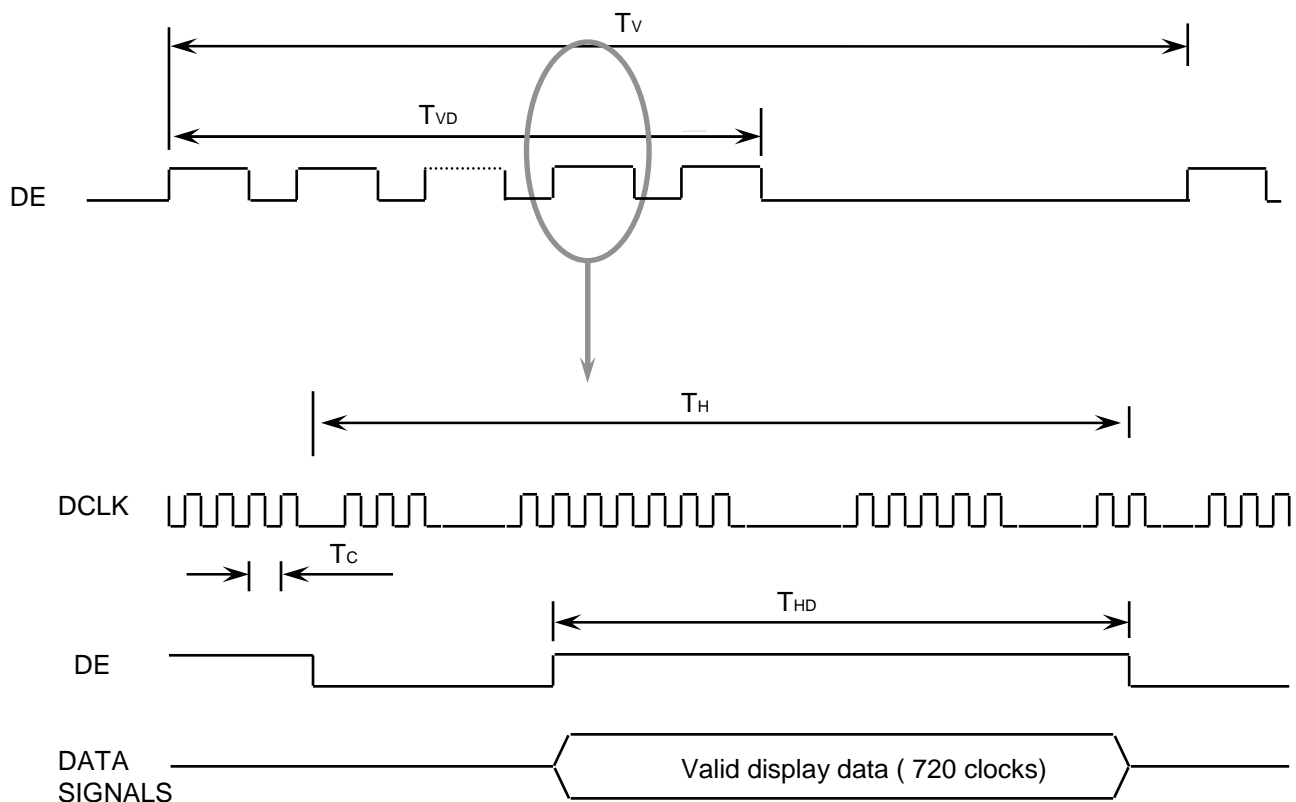

**Samsung Secret**

### 6.3 Power ON/OFF Sequence

Preliminary

: To prevent a latch-up or DC operation of the LCD module, the power on/off sequence should be as the diagram below.

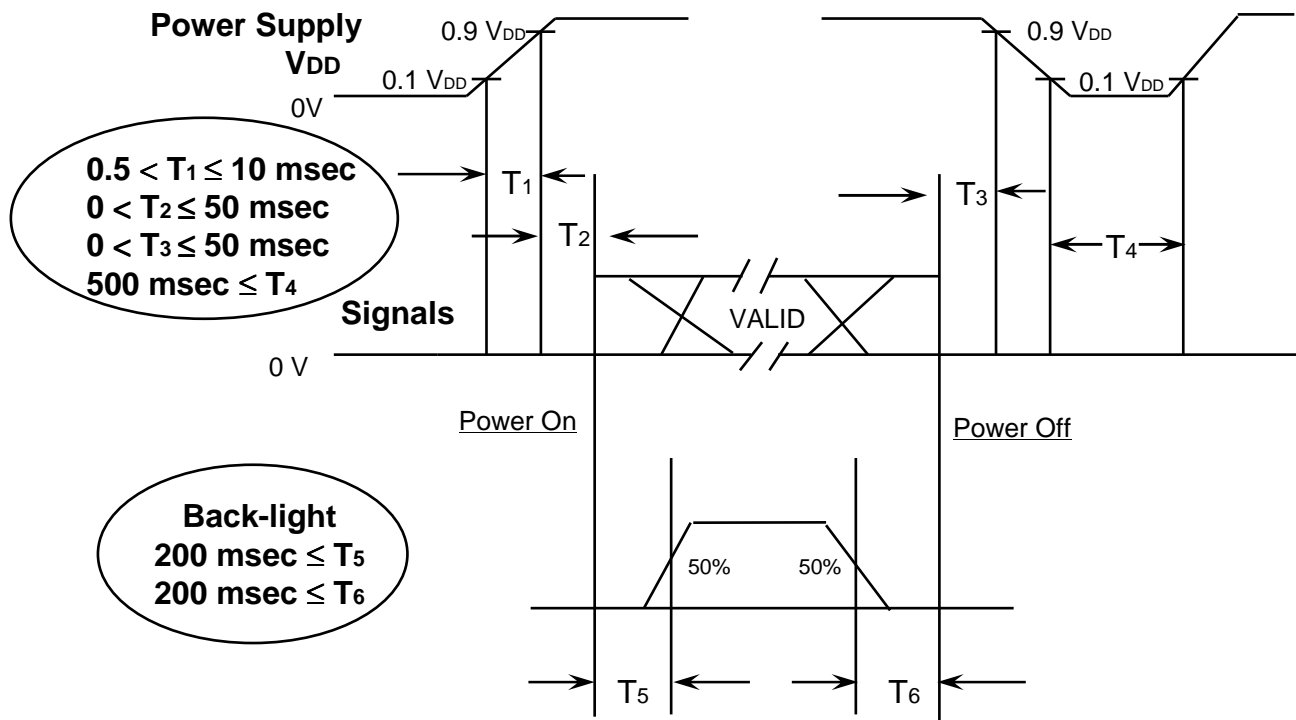

Power ON/OFF Sequence

- T1 : Vdd rising time from 10% to 90%
- T2 : The time from Vdd to valid data at power ON.
- T3 : The time from valid data off to Vdd off at power Off.
- T4 : Vdd off time for Windows restart
- T5 : The time from valid data to B/L enable at power ON.
- T6 : The time from valid data off to B/L disable at power Off.

**NOTE.**

- (1) The supply voltage of the external system for the module input should be the same as the definition of  $V_{DD}$ .
- (2) Apply the lamp voltage within the LCD operation range. When the back-light turns on before the LCD operation or the LCD turns off before the back-light turns off, the display may momentarily become white.
- (3) In case of  $V_{DD} = \text{off level}$ , please keep the level of input signals on the low or keep a high impedance.
- (4) T4 should be measured after the module has been fully discharged between power off and on period.
- (5) Interface signal shall not be kept at high impedance when the power is on.

**Samsung Secret**

## 7. MECHANICAL OUTLINE DIMENSION

Preliminary

[ Refer to the next page ]

**Samsung Secret**

<b>Doc.No.</b>	LTN170BT09-001	<b>Rev.No</b>	04-A00-S-080617	<b>Page</b>	23 / 33
----------------	----------------	---------------	-----------------	-------------	---------

PRELIMINARY

NO	PART NAME	CODE NO	SPECIFICATION	QTY	SPEC NO.	REMARK
1	OUTLINE	LTN170BT00-001				

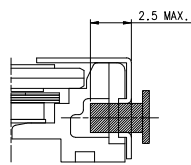
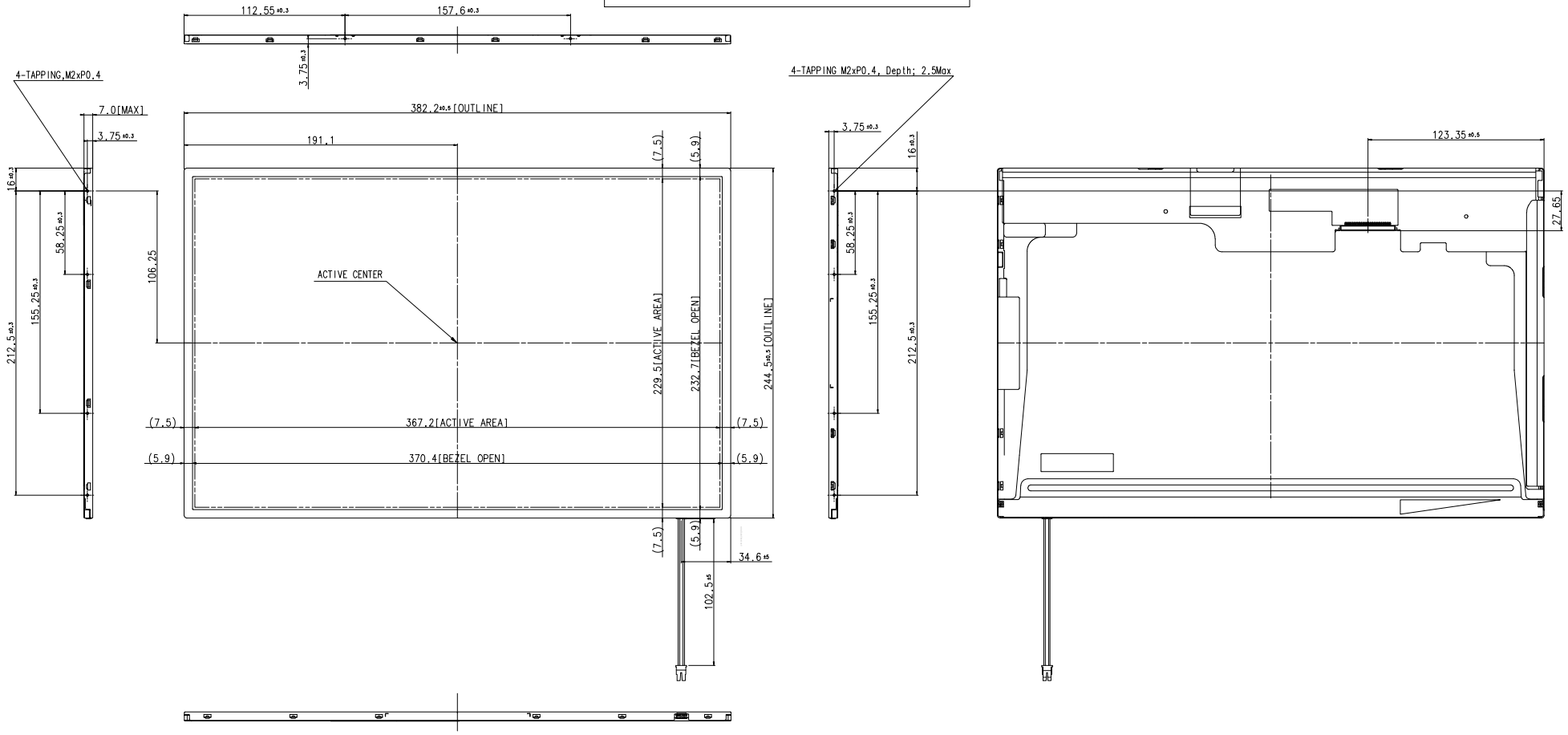

USERHOLE SCREW PENETRATION DEPTH SPEC.

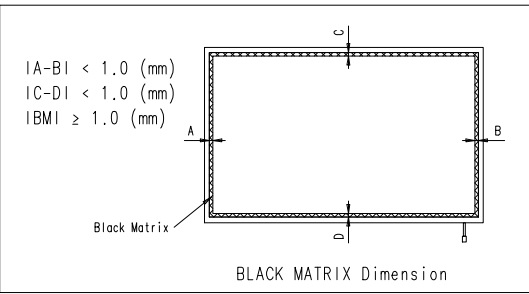

- IA-BI < 1.0 (mm)
- IC-DI < 1.0 (mm)
- IBM1 ≥ 1.0 (mm)

BLACK MATRIX Dimension

\*NOTE

GENERAL TOLERANCE				BLACK MATRIX (userhole screw spec., M4 etc.)				CUSTOMER REQUEST					
STEP	LEVEL	LEVEL 2	LEVEL 3	UNIT	DESCRIPTION	DESCRIPTION	REVISION	MODEL NAME	PART/SHEET NAME	SPEC. NO.	CODE NO.	CHK'D BY	DATE
0	± 0.4	± 0.05	± 0.1	mm	SHA-18 BY	DES-D BY	APP-D BY	LTN170BT00-001	OUTLINE DIMENSION				
4	± 0.16	± 0.08	± 0.15	mm	SHA-18 BY	DES-D BY	APP-D BY						
16	± 0.64	± 0.32	± 0.25	mm	SHA-18 BY	DES-D BY	APP-D BY						
64	± 2.56	± 1.28	± 1.0	mm	SHA-18 BY	DES-D BY	APP-D BY						



## 8. Packing

### 8.1 Packing

CARTON(Internal Package)

#### (1)Packing Form

Corrugated fiberboard box and corrugated cardboard as shock absorber

#### (2)Packing Method

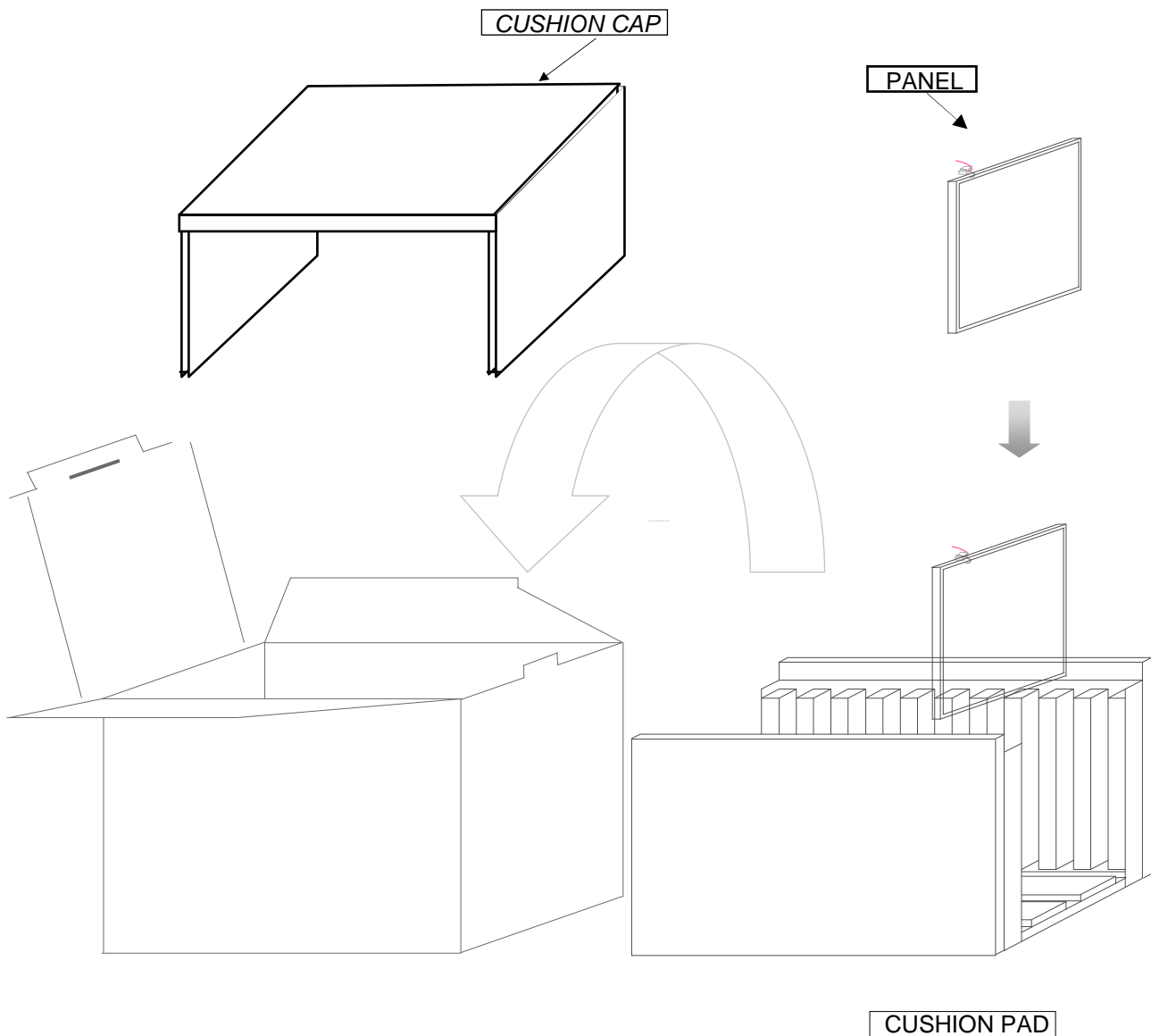

Note (1)Total : Approx. 10.0Kg

(2)Acceptance number of piling : 10 sets

(3)Carton size : 465 (W) X 360(D) X 335(H)

**Samsung Secret**

Doc.No.	LTN170BT09-001	Rev.No	04-A00-S-080617	Page	25 / 33
---------	----------------	--------	-----------------	------	---------

## (3)Packing Material

No	Part name	Quantity
1	Static electric protective sack	10
2	Packing case (Inner box) included shock absorber	1 set
3	Pictorial marking	2 pcs
4	Carton	1 set

**Samsung Secret**

## 8. Product Markings and Others

A nameplate bearing followed by is affixed to a shipped product at the specified location on each product.

- (1) Parts number : LTN170BT09
- (2) Revision : Three letter
- (3) Control code : One letter
- (4) Lot number : X X X \_ X X X X X X X X

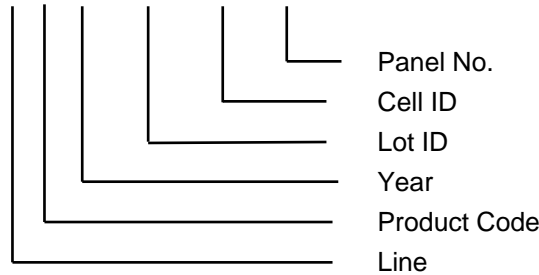

NOTE 1). This code indicating year is omitted in the products of Chun-an site.

### (5) Product Label Definition



- TFT-LCD Product name : LTN170BT09
- Lot number : XXXXXXXXXXXX
- Revision Code : 001
- Inspected work week : 0818(2008 Year, 18<sup>th</sup> week)
- P/N : Lenovo Part Number (42T0539)
- EC NO : Engineering Change Number (Blank)
- FRU : Field Replaceable Unit Part Number(42T0540)
- Header Code : 1ZEJU
- Lenovo Barcode : XXXXXXXXXXXX1ZEJU XXXXXX XXX

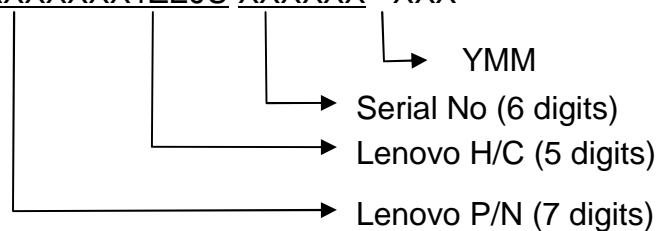

**Samsung Secret**

High voltage caution label

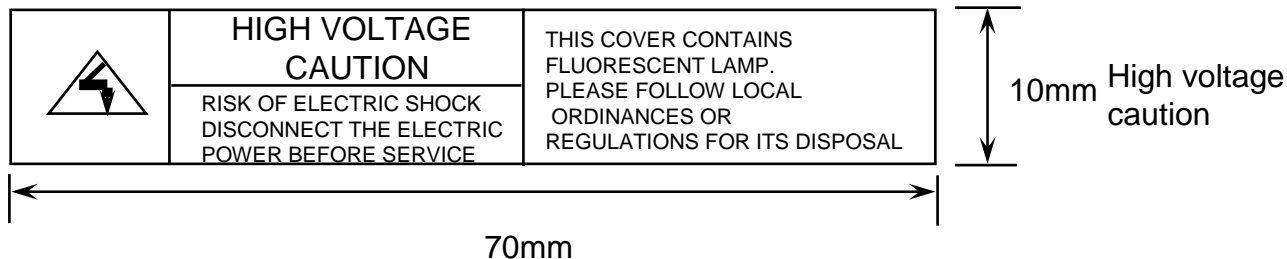

(6) Packing small box attach

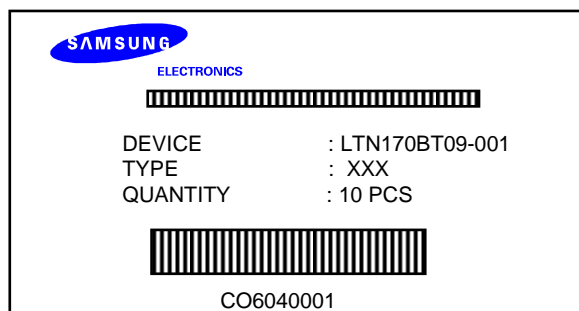

(7) Packing box Marking : Samsung TFT-LCD Brand Name



**Samsung Secret**

## 10. GENERAL PRECAUTIONS

Preliminary

### 1. Handling

- (a) When the module is assembled, It should be attached to the system firmly using every mounting holes. Be careful not to twist and bend the modules.
- (b) Refrain from strong mechanical shock and / or any force to the module. In addition to damage, this may cause improper operation or damage to the module and CCFT back-light.
- (c) Note that polarizers are very fragile and could be easily damaged. Do not press or scratch the surface harder than a HB pencil lead.
- (d) Wipe off water droplets or oil immediately. If you leave the droplets for a long time, Staining and discoloration may occur.
- (e) If the surface of the polarizer is dirty, clean it using some absorbent cotton or soft cloth.
- (f) The desirable cleaners are water, IPA (Isopropyl Alcohol) or Hexane. Do not use Ketone type materials(ex. Acetone), Ethyl alcohol, Toluene, Ethyl acid or Methyl chloride. It might permanent damage to the polarizer due to chemical reaction.
- (g) If the liquid crystal material leaks from the panel, it should be kept away from the eyes or mouth. In case of contact with hands, legs or clothes, it must be washed away thoroughly with soap.
- (h) Protect the module from static, it may cause damage to the C-MOS Gate Array IC.
- (i) Use fingerstalls with soft gloves in order to keep display clean during the incoming inspection and assembly process.
- (j) Do not disassemble the module.
- (k) Do not pull or fold the lamp wire.
- (l) Do not adjust the variable resistor which is located on the back side.
- (m) Protection film for polarizer on the module shall be slowly peeled off just before use so that the electrostatic charge can be minimized.
- (n) Pins of I/F connector shall not be touched directly with bare hands.

**Samsung Secret**

<b>Doc.No.</b>	LTN170BT09-001	<b>Rev.No</b>	04-A00-S-080617	<b>Page</b>	29 / 33
----------------	----------------	---------------	-----------------	-------------	---------

## 2. STORAGE

- (a) Do not leave the module in high temperature, and high humidity for a long time.  
It is highly recommended to store the module with temperature from 0 to 35 °C and relative humidity of less than 70%.
- (b) Do not store the TFT-LCD module in direct sunlight.
- (c) The module shall be stored in a dark place. It is prohibited to apply sunlight or fluorescent light during the store.

## 3. OPERATION

- (a) Do not connect, disconnect the module in the “ Power On” condition.
- (b) Power supply should always be turned on/off by following item 6.3  
“ Power on/off sequence “.
- (c) Module has high frequency circuits. Sufficient suppression to the electromagnetic interference shall be done by system manufacturers. Grounding and shielding methods may be important to minimize the interference.
- (d) The cable between the back-light connector and its inverter power supply shall be a minimized length and be connected directly . The longer cable between the back-light and the inverter may cause lower luminance of lamp(CCFT) and may require higher startup voltage (Vs).
- (e) The standard limited warranty is only applicable when the module is used for general notebook applications. If used for purposes other than as specified, SEC is not to be held reliable for the defective operations. It is strongly recommended to contact SEC to find out fitness for a particular purpose.

## 4. OTHERS

- (a) Ultra-violet ray filter is necessary for outdoor operation.
- (b) Avoid condensation of water. It may result in improper operation or disconnection of electrode.
- (c) Do not exceed the absolute maximum rating value. ( the supply voltage variation, input voltage variation, variation in part contents and environmental temperature, so on)  
Otherwise the module may be damaged.
- (d) If the module displays the same pattern continuously for a long period of time, it can be the situation when the image “sticks” to the screen.
- (e) This module has its circuitry PCB's on the rear side and should be handled carefully in order not to be stressed.

**Samsung Secret**

<b>Doc.No.</b>	LTN170BT09-001	<b>Rev.No</b>	04-A00-S-080617	<b>Page</b>	30 / 33
----------------	----------------	---------------	-----------------	-------------	---------

# 11. EDID

Preliminary

Address (HEX)	FUNCTION	Value	BIN	DEC	ASCII or Data	Notes
		HEX				
00	Header	00	00000000	0		EDID Header
01		FF	11111111	255		
02		FF	11111111	255		
03		FF	11111111	255		
04		FF	11111111	255		
05		FF	11111111	255		
06		FF	11111111	255		
07		00	00000000	0		
08	ID Manufacturer Name	30	00110000	48	L E N	3 character ID
09		AE	10101110	174		"LEN" as an end-customer
0A		ID Product Code	60	01100000		96
0B	40		01000000	64		
0C	32-bit serial no.	00	00000000	0		
0D		00	00000000	0		
0E		00	00000000	0		
0F		00	00000000	0		
10	Week of manufacture	00	00000000	0		
11	Year of manufacture	12	00010010	18	2008	2008
12	EDID Structure Ver.	01	00000001	1	1	EDID Ver. 1.0
13	EDID revision #	03	00000011	3	3	EDID Rev. 3
14	Video input definition	80	10000000	128		
15	Max H image size	25	00100101	37	37	37 cm(approx)
16	Max V image size	17	00010111	23	23	23 cm(approx)
17	Display Gamma	78	01111000	120	2.2	Gamma 2.2
18	Feature support	EA	11101010	234		
19	Red/green low bits	CD	11001101	205		10000111
1A	Blue/white low bits	75	01110101	117		11111110
1B	Red x/ high bits	91	10010001	145	0.569	Red x 0.580= 1001010010
1C	Red y	55	01010101	85	0.332	Red y 0.340= 0101011100
1D	Green x	4F	01001111	79	0.312	Green x 0.310= 0100111101
1E	Green y	8B	10001011	139	0.544	Green y 0.550= 1000110011
1F	Blue x	26	00100110	38	0.149	Blue x 0.155= 0010011111
20	Blue y	21	00100001	33	0.132	Blue y 0.155= 0010011111
21	White x	50	01010000	80	0.313	White x 0.313= 0101000001
22	White y	54	01010100	84	0.329	White y 0.329= 0101010001
23	Established timing 1	00	00000000	0		
24	Established timing 2	00	00000000	0		
25	Established timing 3	00	00000000	0		

**Samsung Secret**

26	Standard timing #1	01	00000001	1		not used
27		01	00000001	1		
28	Standard timing #2	01	00000001	1		not used
29		01	00000001	1		
2A	Standard timing #3	01	00000001	1		not used
2B		01	00000001	1		
2C	Standard timing #4	01	00000001	1		not used
2D		01	00000001	1		
2E	Standard timing #5	01	00000001	1		not used
2F		01	00000001	1		
30	Standard timing #6	01	00000001	1		not used
31		01	00000001	1		
32	Standard timing #7	01	00000001	1		not used
33		01	00000001	1		
34	Standard timing #8	01	00000001	1		not used
35		01	00000001	1		
36	Detailed timing/monitor descriptor #1	32	00110010	50	97.78	Main clock= 97.78 MHz (@60Hz)
37		26	00100110	38		
38		A0	10100000	160	1440	Hor active=720*2 pixels
39		40	01000000	64	320	Hor blanking=320pixels
3A		51	01010001	81		4bit : 4bit
3B		84	10000100	132	900	Vertical active=900 lines
3C		1A	00011010	26	26	Vertical blanking=26 lines
3D		30	00110000	48		4bit : 4bit
3E		30	00110000	48	48	Hor sync. Offset=48 pixels
3F		20	00100000	32	32	H sync. Width=32 pixels
40		36	00110110	54	3 6	V sync. Offset=3 lines V sync. Width=6 lines
41		00	00000000	0		2bit : 2bit :2bit :2bit
42		6F	01101111	111	367	H image size= 367 mm(approx)
43		E6	11100110	230	230	V image size = 230 mm(approx)
44		10	00010000	16		
45		00	00000000	0		No Horizontal Border
46	00	00000000	0		No Vertical Border	
47	19	00011001	25			
48	Detailed timing/monitor descriptor #2	D5	11010101	213	81.49	Main clock= 81.49 MHz (@50Hz)
49		1F	00011111	31		
4A		A0	10100000	160	1440	Hor active=720*2 pixels
4B		40	01000000	64	320	Hor blanking=320 pixels
4C		51	01010001	81		4bit : 4bit
4D		84	10000100	132	900	Vertical active=900 lines
4E		1A	00011010	26	26	Vertical blanking=26 lines
4F		30	00110000	48		4bit : 4bit
50		30	00110000	48	48	Hor sync. Offset=48 pixels
51		20	00100000	32	32	H sync. Width=32 pixels
52		36	00110110	54	3 6	V sync. Offset=3 lines V sync. Width=6 lines
53		00	00000000	0		2bit : 2bit :2bit :2bit
54		6F	01101111	111	367	H image size= 367 mm(approx)
55		E6	11100110	230	230	V image size = 230 mm(approx)
56		10	00010000	16		
57		00	00000000	0		No Horizontal Border
58	00	00000000	0		No Vertical Border	
59	19	00011001	25			

**Samsung Secret**



5A	descriptor #3	00	00000000	0		Manufacturer Specified (Timing)
5B		00	00000000	0		
5C		00	00000000	0		
5D		0F	00001111	15		
5E		00	00000000	0		
5F		95	10010101	149		(Horizontal active pixel /8)-31
60		0A	00001010	10		Image Aspect Ratio(16:10)
61		32	00110010	50		Low Refresh Rate #1(50Hz)
62		95	10010101	149		(Horizontal active pixel /8)-31
63		0A	00001010	10		Image Aspect Ratio(16:10)
64		28	00101000	40		Low Refresh Rate #1(40Hz)
65		14	00010100	20		Brightness(1/10nit)
66		01	00000001	1		Feature flag(TN mode)
67		00	00000000	0		
68		4C	01001100	76		supplier ID "SEC"
69		A3	10100011	163		
6A		42	01000010	66	[B]	Product code "BT"
6B	54	01010100	84	[T]	(Hex, LSB first)	
6C	Detailed timing/monitor descriptor #4	00	00000000	0		Monitor Name Tag (ASCII)
6D		00	00000000	0		
6E		00	00000000	0		
6F		FE	11111110	254		
70		00	00000000	0		
71		4C	01001100	76	[L]	
72		54	01010100	84	[T]	
73		4E	01001110	78	[N]	
74		31	00110001	49	[1]	
75		37	00110111	55	[7]	
76		30	00110000	48	[0]	
77		42	01000010	66	[B]	
78		54	01010100	84	[T]	
79		30	00110000	48	[0]	
7A		39	00111001	57	[9]	
7B		30	00110000	48	[0]	
7C		30	00110000	48	[0]	
7D	31	00110001	49	[1]		
7E	Extension Flag	00	00000000	0		
7F	Checksum	B0	10110000	176		

Samsung Secret