



Light LED

Product Data Sheet

LTPA-C0800MXE

Spec No.: DS25-2014-0228

Effective Date: 11/01/2014

Revision: -

LITE-ON DCC

RELEASE

BNS-OD-FC001/A4

Light LED LTPA-C0800MXE

1. Description

The LiteOn White LED is a revolutionary, energy efficient and ultra-compact new light source, combining the lifetime and reliability advantages of Light Emitting Diodes with the brightness of conventional lighting. It gives you total design freedom and unmatched brightness, creating a new opportunities for solid state lighting to displace conventional lighting technologies

1.1 Features

- Meet RoHS and HF
- Highest brightness SMD LED
- Package in 16mm tape on 7" diameter reels.
- I.C. compatible
- Compatible with automatic placement equipment
- Compatible with infrared reflow solder process

1.2 Applications

- Automotive aftermarket eg: DRL, Reading light

2. Package Dimensions

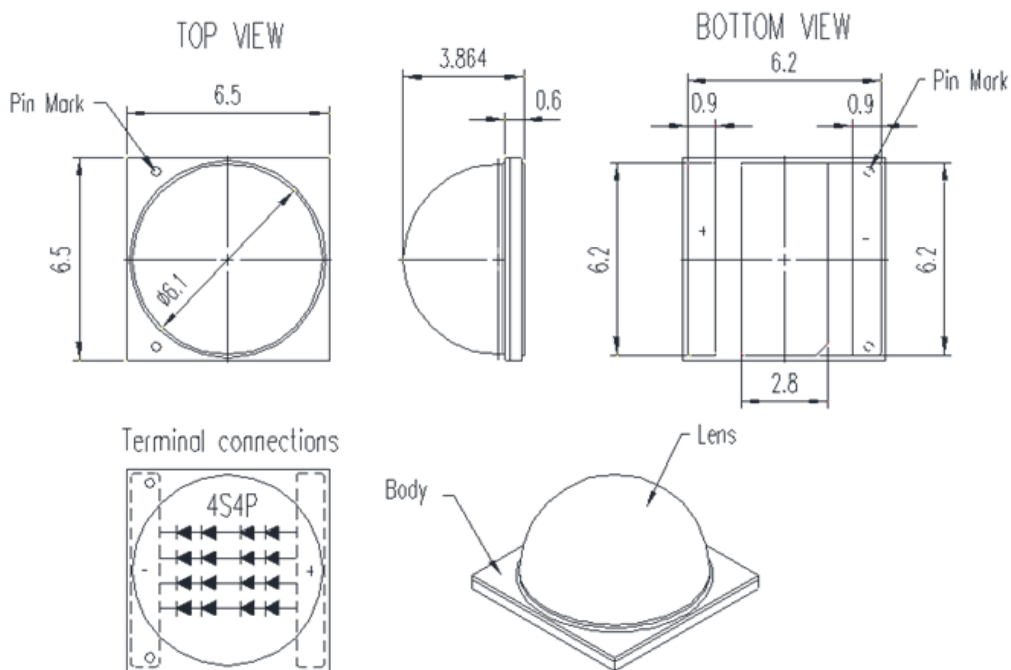

Part No.	Lens Color	Source Color
LTPA-C0800MXE	Orange	InGaN White

Notes:

1. All dimensions are in millimeters and dimension tolerances are $\pm 0.2\text{mm}$, except lens height and ceramic length/width dimensions tolerance are $\pm 0.1\text{mm}$
2. Dimensions without tolerances are for reference only.

Light LED LTPA-C0800MXE

3. Rating and Characteristics

3.1 Absolute Maximum Ratings at Ta=25°C

Parameter	Symbol	Rating	Unit
Power Dissipation	P _o	10	W
DC Forward Current	I _F	700	mA
Junction Temperature	T _j	125	°C
Thermal Resistance, Junction-Case	R _{th, J-C}	3.3	°C / W
Operating Temperature Range	T _c	-40~+85	°C
Storage Temperature Range	T _{stg}	-55~+100	°C

Notes :

1. Forbid to operating at reverse voltage condition
2. ESD spec is reference to AEC-Q101-001 HBM.
3. The unit of R_{th} is °C/W electrical.
4. Thermal resistance measurement tolerance is ± 10%
5. All reliability items are mounted on thermal heat sink with 2cmX 2cm Metal Core PCB.

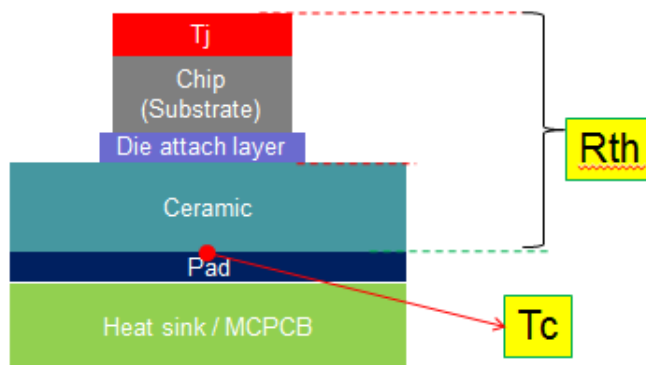

Light LED LTPA-C0800MXE

3.2 Electro-Optical Characteristics

■ Typical Performance

Parameter	Symbol	Values			Unit	Test Condition
		Min	Typ.	Max		
Correlated Color Temperature	CCT	3000	--	5700	K	I _F = 700mA
Color Rendering Index	CRI	70	--	--	-	
Viewing Angle	2θ _{1/2}	--	130	--	deg	
Forward Voltage	V _F	11.5	12.5	13.5	V	

Notes

1. All of the VF value please refer page 7 "VF Binning Parameter".
2. The Flux value please refer page 7~8 "Flux Binning Parameter".
3. Tolerance of Flux is ±10%, Tolerance of VF is ±5%, tolerance of CCx/CCy is ±0.01, tolerance of CRI is ±3.
4. LEDs are lighted up and measured with externally parallel connecting leads of LED.
5. Typical viewing angle is 130deg.

Light LED LTPA-C0800MXE

4. Typical Electrical/Optical Characteristics Curve

■ Efficiency Comparison Table

4.1 Relative Flux vs. Current of LTPA-C0800MXE at 25°C

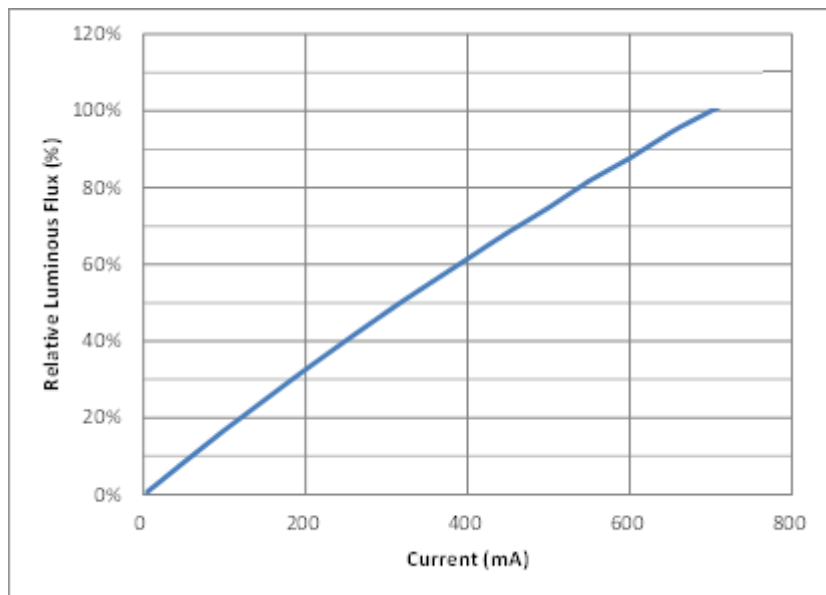

Fig 1. Typical relative luminous flux vs. forward current of LTPA-C0800MXE

**Light LED
LTPA-C0800MXE**

4.2 Typical Spatial Radiation Pattern

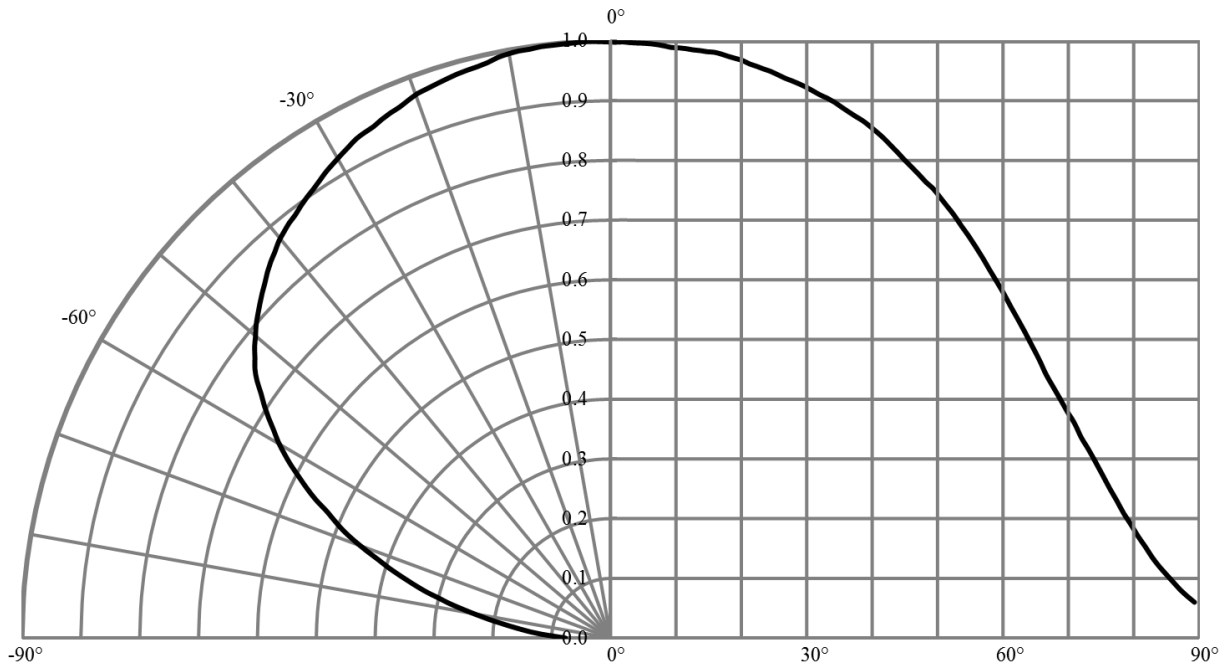

Fig 2. Radiation Characteristics

Light LED LTPA-C0800MXE

4.3 Forward Current vs. Forward Voltage at 25°C

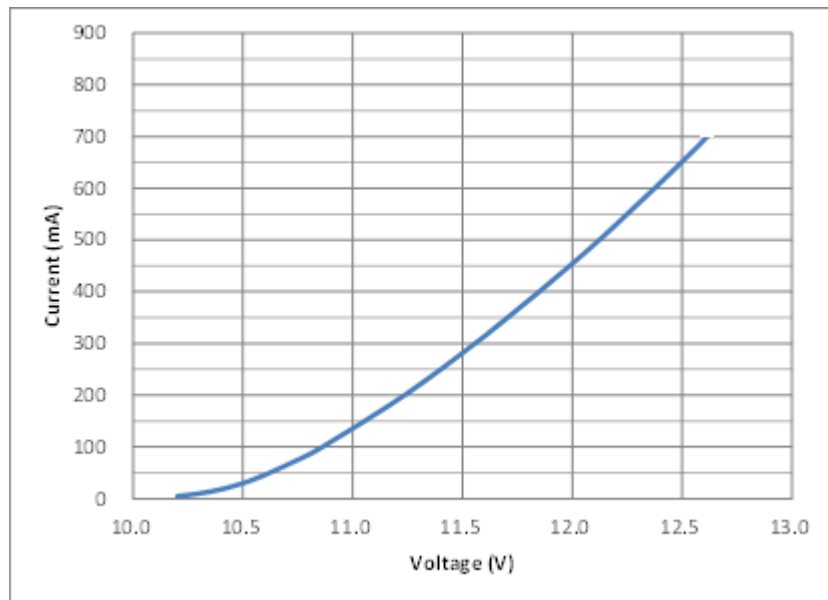

Fig 3. Forward Current vs. Forward Voltage of LTPA-C0800MXE

4.4 Maximum Forward Current vs. Operating Temperature

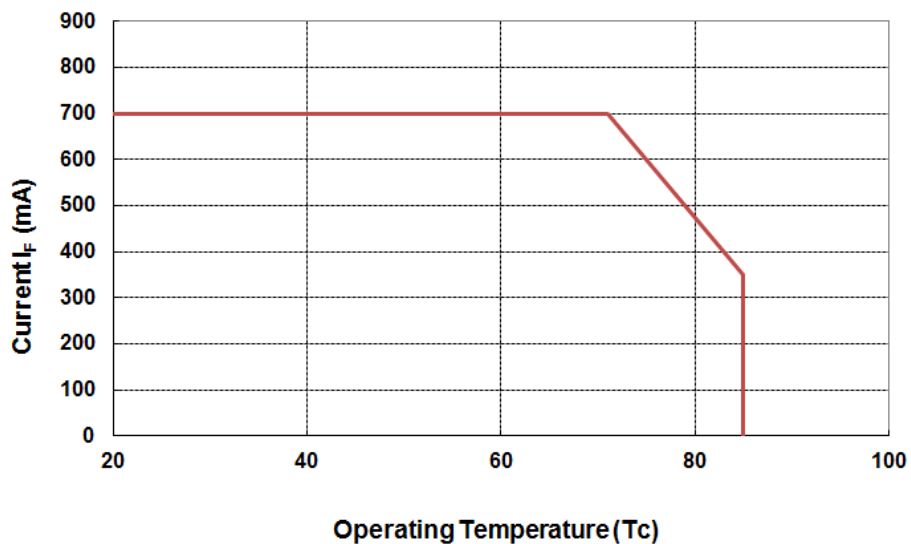

Fig 4. Forward Current Degrading Curve of LTPA-C0800MXE

Light LED LTPA-C0800MXE

5. VF Bin Definition

5.1 Forward Voltage Binning Parameter at 25°C

■ LTPA-C0800MXE

Parameter	Bin	Symbol	Min	Max	Unit	Condition
Forward Voltage	DC1	VF	11.5	12.0	V	IF = 700mA
Forward Voltage	DC2	VF	12.0	12.5	V	IF = 700mA
Forward Voltage	DC3	VF	12.5	13.0	V	IF = 700mA
Forward Voltage	DC4	VF	13.0	13.5	V	IF = 700mA

Tolerance on each Forward Voltage bin is ±5%

6. Flux Bin Definition

6.1 Luminous Flux Binning Parameter at 25°C

■ LTPA-C0800MXE

CRI 70 Series

3000K

Parameter	Bin	Symbol	Min	Max	Unit	condition
Luminous Flux	SU	ΦV	1016	1098	lm	If=700mA
	UW		1098	1190		
	WY		1190	1281		

4000K

Parameter	Bin	Symbol	Min	Max	Unit	condition
Luminous Flux	TV	ΦV	1052	1144	lm	If=700mA
	VX		1144	1235		
	XZ		1235	1336		

5000K

Parameter	Bin	Symbol	Min	Max	Unit	condition
Luminous Flux	TV	ΦV	1052	1144	lm	If=700mA
	VX		1144	1235		
	XZ		1235	1336		

Light LED
LTPA-C0800MXE

5700K

Parameter	Bin	Symbol	Min	Max	Unit	condition
Luminous Flux	TV	ΦV	1052	1144	lm	If=700mA
	VX		1144	1235		
	XZ		1235	1336		

Tolerance on each Luminous Flux bin is $\pm 10\%$

Light LED LTPA-C0800MXE

Color Bin Definition

7.1 Chromaticity Coordinate Groups at 25°C

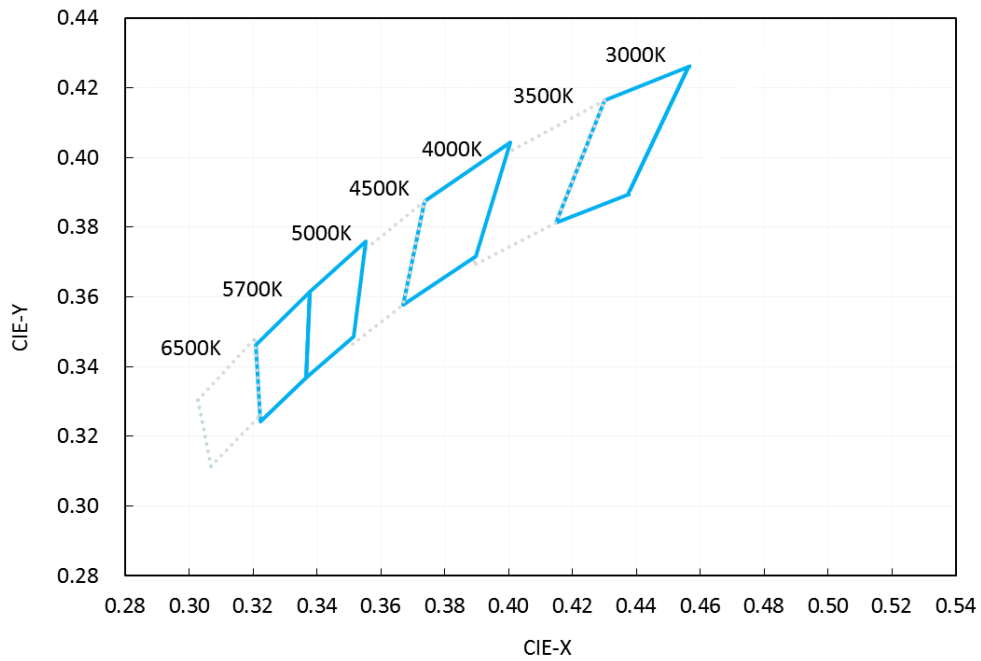

Notes

1. The Chromaticity Coordinate Groups follow ANSI 7-Step MacAdam Quadrangle
2. The (CIE_x, CIE_y) center follow ANSI Quadrangle

Light LED LTPA-C0800MXE

7.2 Chromaticity Coordinate Category Code Table at 25°C

■ 3000K Series

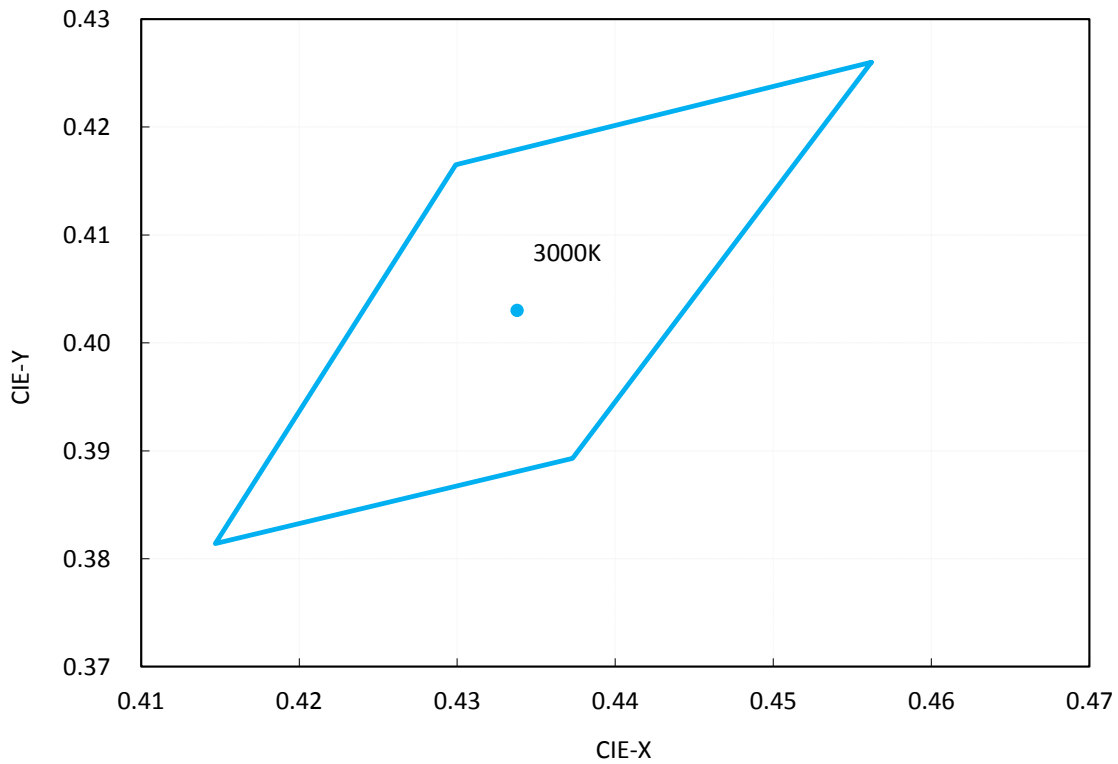

	CIE-X	CIE-Y
Center point	0.4338	0.4030
XD (CRI 70)	0.4562	0.4260
	0.4299	0.4165
	0.4147	0.3814
	0.4373	0.3893
	0.4562	0.4260

Tolerance on each Hue bin (x,y) is +/- 0.01

Light LED LTPA-C0800MXE

■ 4000K Series

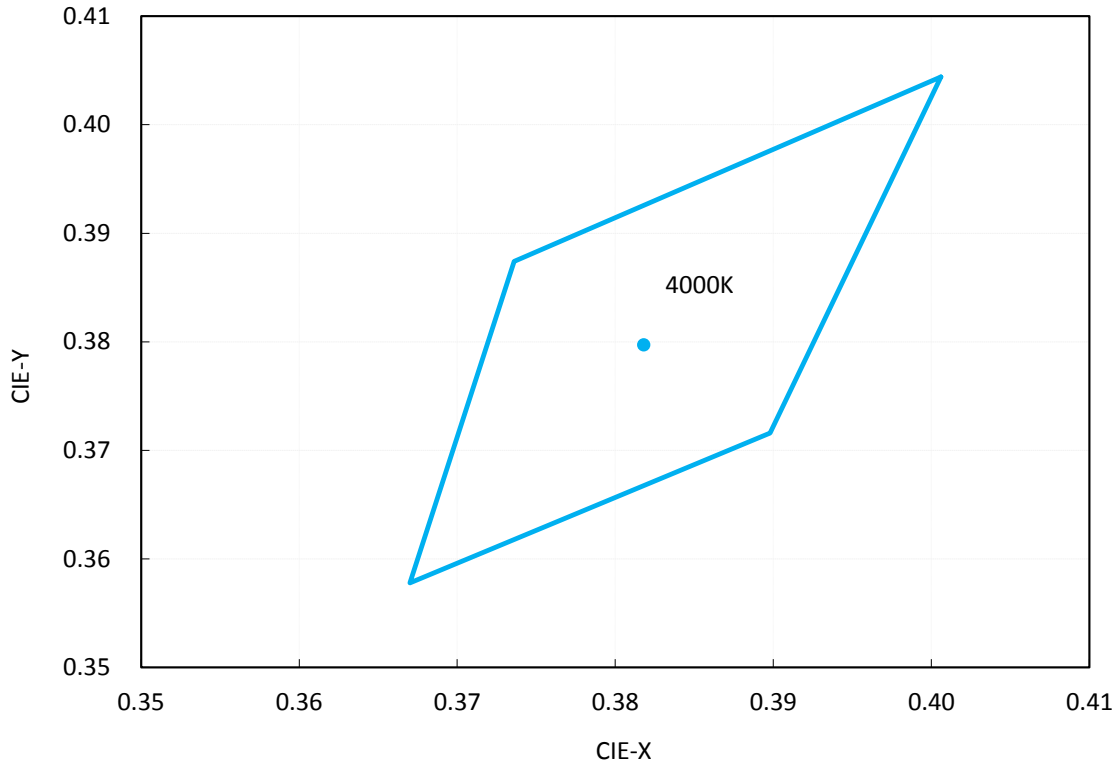

	CIE-X	CIE-Y
Center point	0.3818	0.3797
XF (CRI 70)	0.4006	0.4044
	0.3736	0.3874
	0.3670	0.3578
	0.3898	0.3716
	0.4006	0.4044

Tolerance on each Hue bin (x,y) is +/- 0.01

Light LED LTPA-C0800MXE

■ 5000K Series

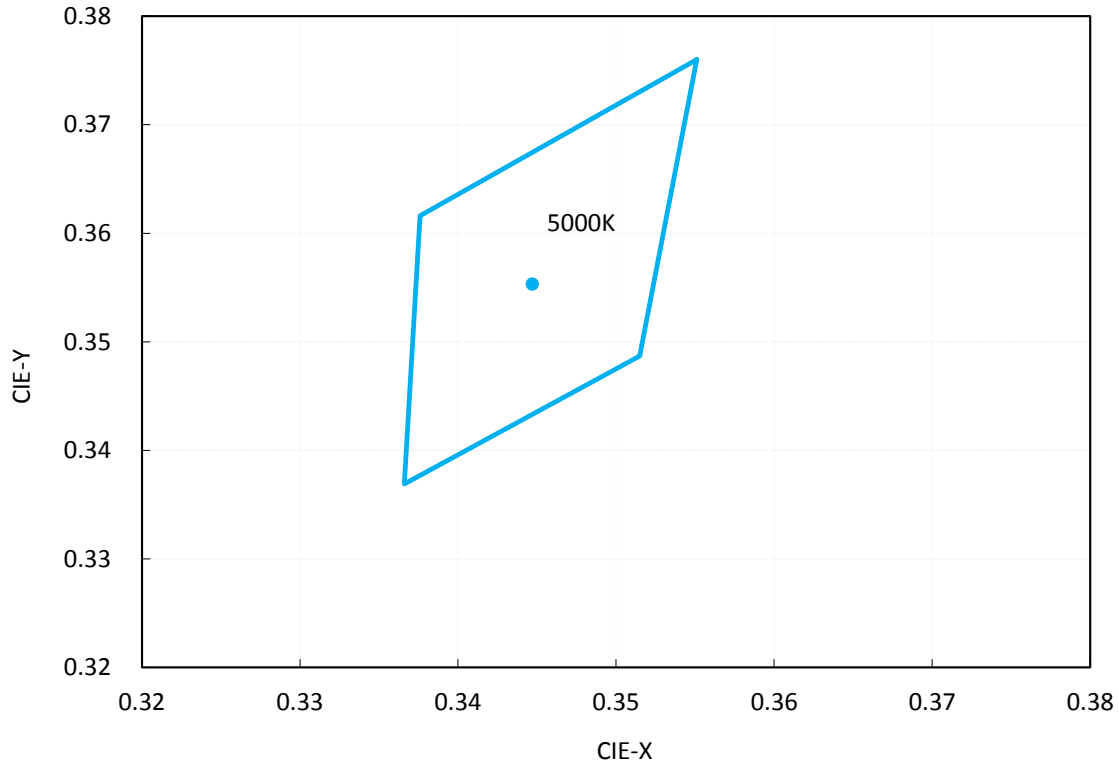

	CIE-X	CIE-Y
Center point	0.3447	0.3553
XH (CRI 70)	0.3551	0.3760
	0.3376	0.3616
	0.3366	0.3369
	0.3515	0.3487
	0.3551	0.3760

Tolerance on each Hue bin (x,y) is +/- 0.01

Light LED LTPA-C0800MXE

■ 5700K Series

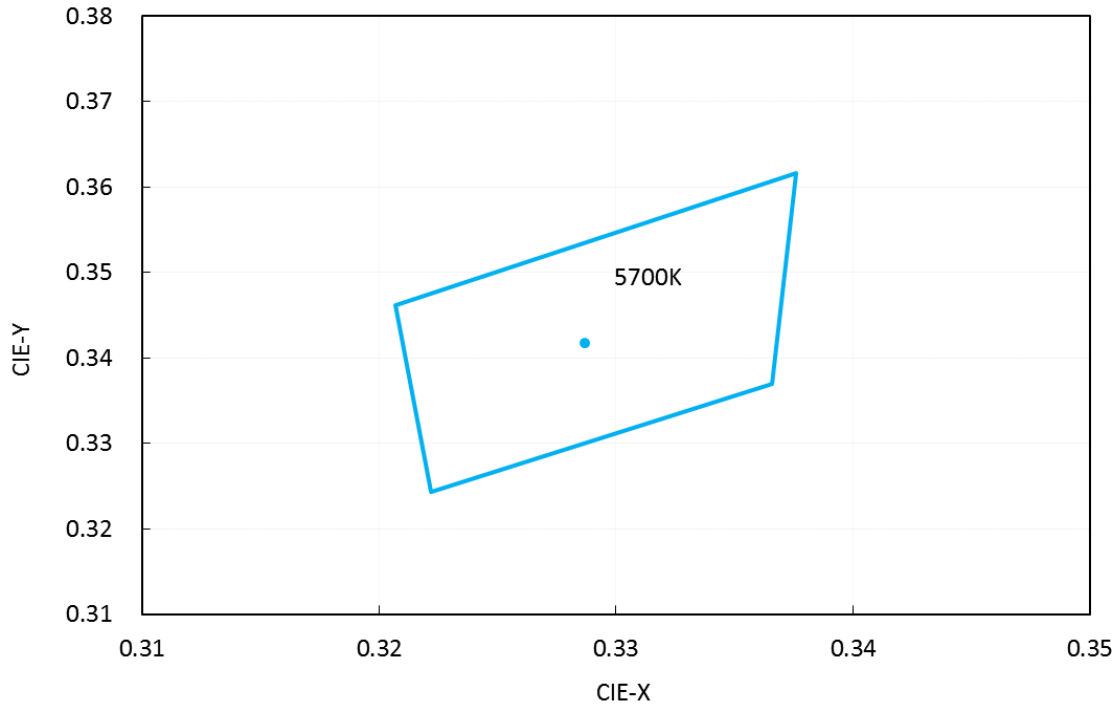

	CIE-X	CIE-Y
Center point	0.3287	0.3417
XI (CRI 70)	0.3376	0.3616
	0.3207	0.3462
	0.3222	0.3243
	0.3366	0.3369
	0.3376	0.3616

Tolerance on each Hue bin (x,y) is +/- 0.01

Light LED LTPA-C0800MXE

7. Reflow Soldering Characteristics

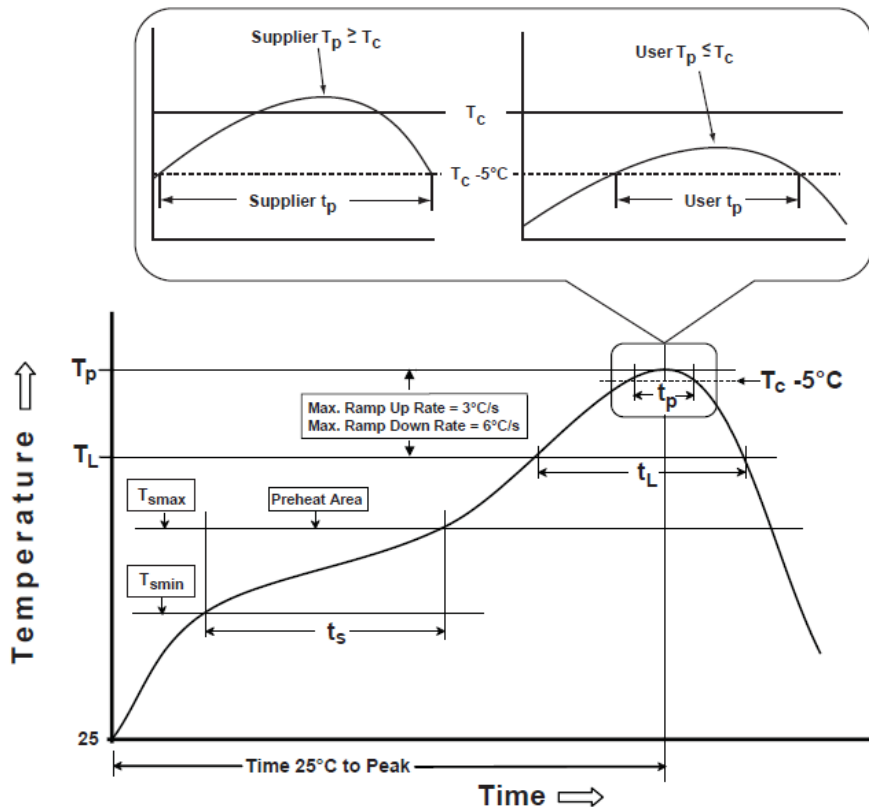

Profile Feature	Lead Free Assembly
Average Ramp-Up Rate (T_{smax} to T_p)	3°C / second max
Preheat Temperature Min (T_{smin})	150°C
Preheat Temperature Max (T_{smax})	200°C
Preheat Time (t_{smin} to t_{smax})	60 – 180 seconds
Time Maintained Above Temperature (T_L)	217°C
Time Maintained Above Time (t_L)	u – 150 seconds
Peak / Classification Temperature (T_p)	255°C
Time Within 5°C of Actual Peak Temperature (t_p)	5 seconds
Ramp – Down Rate	6°C / second max
Time 25°C to Peak Temperature	8 minutes max

Light LED LTPA-C0800MXE

Notes:

1. The LEDs can be soldered using the reflow soldering or hand soldering method. The recommended hand soldering condition is 350°C max. and 2secs max. for one time only, and the recommended reflow soldering condition is 260°C max. and 5secs max. for three times max.
2. All temperatures refer to topside of the package, measured on the package body surface.
3. The soldering condition referring to J-STD-020. The storage ambient for the LEDs should not exceed 30°C temperature or 70% relative humidity. It is recommended that LEDs out of their original packaging are soldered within one week. For extended storage out of their original packaging, it is recommended that the LEDs were stored in a sealed container with appropriate desiccant, or desiccators with nitrogen ambient. If the LEDs were unpacked more than 168hrs, baking the LEDs at 60°C for 24hrs before soldering process.
4. The soldering profile could be further referred to different soldering grease material characteristic. The grease vendor will provide this information.
5. A rapid-rate process is not recommended for the LEDs cooling down from the peak temperature.
6. Although the recommended reflow conditions are specified above, the reflow or hand soldering condition at the lowest possible temperature is desirable for the LEDs.
7. LiteOn cannot make a guarantee on the LEDs which have been already assembled using the dip soldering method.

Light LED LTPA-C0800MXE

8. Reliability Test Plan

■ LTPA-C0800MXE

No	Test item	Condition	Duration	Number of Failed
1	High Temperature Operating Life (HTOL)	Tc=95°C, IF=700mA DC (0, 250, 500, 750, 1000hrs)	1K hrs	0/20
2	Room Temperature Operating Life (RTOL)	Tc=55°C, IF=700mA DC (0, 250, 500, 750, 1000hrs)	1K hrs	0/20
3	Power Temperature Cycle (PTMCL)	-40°C to 105°C 15minutes dwell/15minutes transfer 5 minutes ON/5 minutes OFF IF=350mA DC	1K cycles	0/20
4	Non-Operating Thermal Shock (TMSK)	-40°C to 125°C 30minutes dwell, <10 seconds transfer measure each 250 cycles (continues to fail, more than 1k cycles)	1K cycles	0/20

Notes:

1. Operating life test are mounted on thermal heat sink
2. Storage item are only component, not put on heat sink.
3. All reliability items are mounted on thermal heat sink with 2cmX 2cm Metal Core PCB

**Light LED
LTPA-C0800MXE**

9. Recommend Soldering Pad Layout

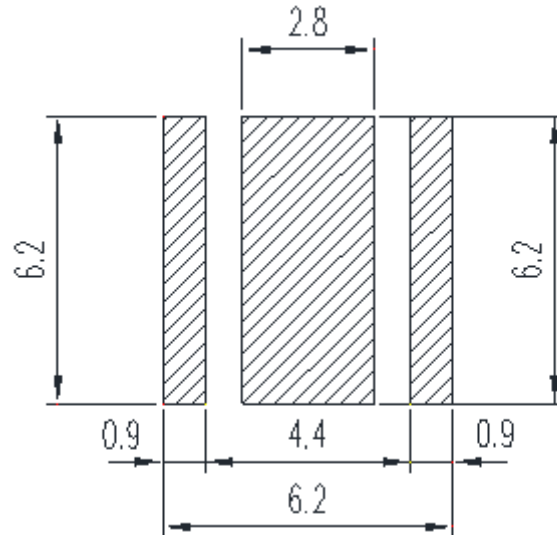
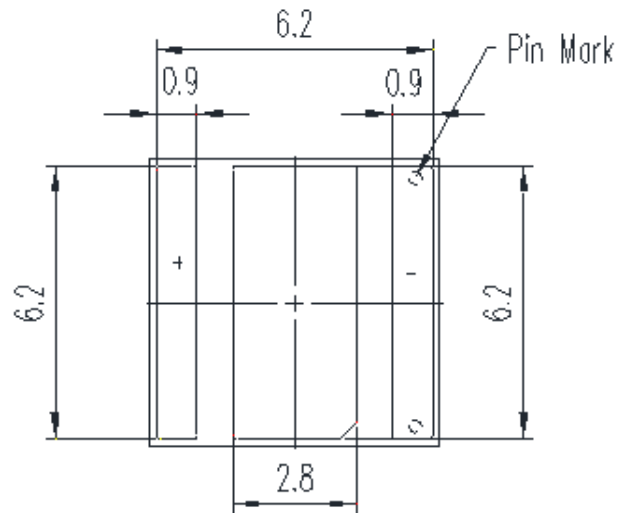

Notes:

1. Suggest stencil thickness is maximum 0.10mm

Light LED LTPA-C0800MXE

10. Package Dimensions of Tape and Reel

Reel Packaging

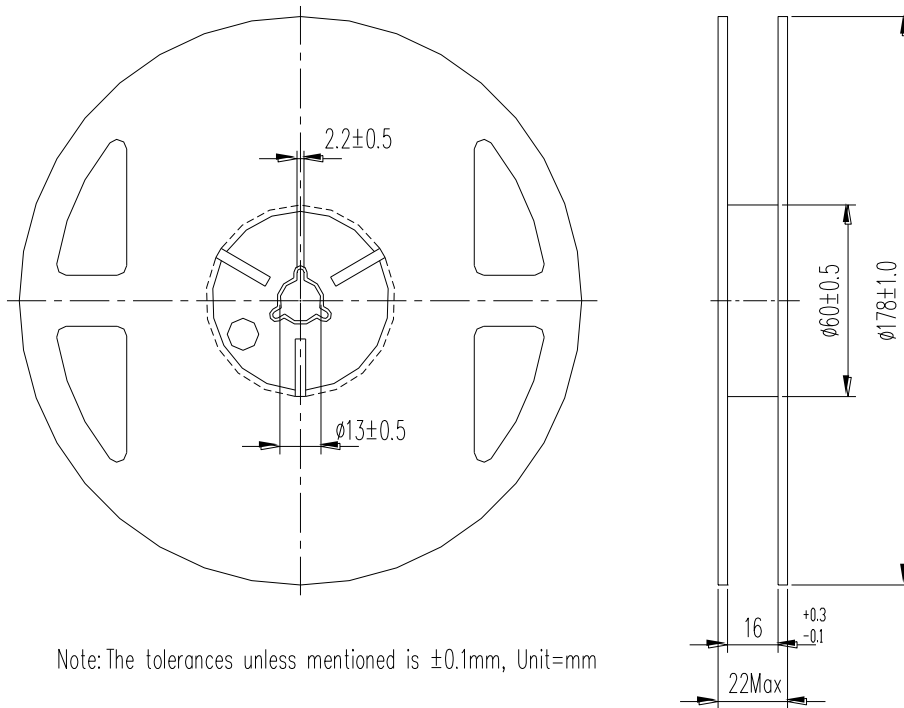

Note: The tolerances unless mentioned is ± 0.1 mm, Unit=mm

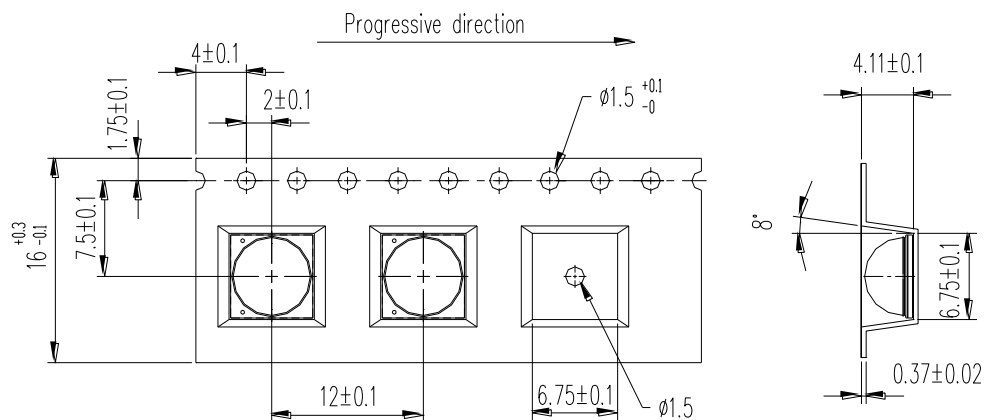

Note:

1. All dimensions are in millimeters.
2. Empty component pockets sealed with top cover tape.

Light LED LTPA-C0800MXE

11. Cautions

12.1 An LED is a current-operated device. In order to ensure intensity uniformity on multiple LEDs connected in parallel in an application, it is recommended that a current limiting resistor be incorporated in the drive circuit, in series with each LED as shown in Circuit below.

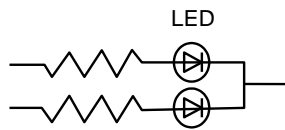

Circuit model A

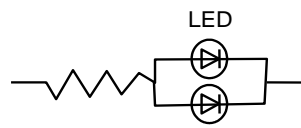

Circuit model B

(A) Recommended circuit.

(B) The brightness of each LED might appear different due to the differences in the I-V characteristics of those LEDs.

12.2 Do not put any pressure on the light emitting surface either by finger or any hand tool and do not stack the COB products. Stress or pressure may cause damage to the wires of the LED array.

12.3 This product is not designed for the use under any of the following conditions, please confirm the performance and reliability are well enough if you use it under any of the following conditions

- Do not use sulfur-containing materials in commercial products including the materials such as seals and adhesives that may contain sulfur.
- Do not put this product in a place with a lot of moisture (over 85% relative humidity), dew condensation, briny air, and corrosive gas (Cl, H₂S, NH₃, SO₂, NO_x, etc.), exposure to a corrosive environment may affect silver plating.

ESD (Electrostatic Discharge)

Static Electricity or power surge will damage the LED. Suggestions to prevent ESD damage:

- Use of a conductive wrist band or anti-electrostatic glove when handling these LEDs.
- All devices, equipment, and machinery must be properly grounded.
- Work tables, storage racks, etc. should be properly grounded.
- Use ion blower to neutralize the static charge which might have built up on surface of the LED's plastic lens as a result of friction between LEDs during storage and handling.

ESD-damaged LEDs will exhibit abnormal characteristics such as high reverse leakage current, low forward voltage, or “no light up” at low currents.

To verify for ESD damage, check for “light up” and VF of the suspect LEDs at low currents.

Light LED LTPA-C0800MXE

■ Lens Handling Remark

The LED should only be picked up by making contact with the sides of the LED body. It should not put any pressure on the lens either by finger or any hand tool. Do not puncture or push the lens. Below figure illustrate correct and incorrect handling.

■ Storage

This product is qualified as Moisture sensitive Level 3 per JEDEC J-STD-020 Precaution when handing this moisture sensitive product is important to ensure the reliability of the product.

The package is sealed:

The LEDs should be stored at 30°C or less and 90%RH or less. And the LEDs are limited to use within one year, while the LEDs is packed in moisture-proof package with the desiccants inside.

The package is opened:

The LEDs should be stored at 30°C or less and 60%RH or less. Moreover, the LEDs are limited to solder process within 168hrs. If exceeding the storage limiting time since opened, that we recommended to baking LEDs at 60°C at least 48hrs. To seal the remainder LEDs return to package, it's recommended to be with workable desiccants in original package.