



Photocoupler

Product Data Sheet

LTV-814 824 844
(M, S, S-TA, S-TA1, S-TP)
Series

Spec No.: DS-70-96-0013

Effective Date: 05/21/2014

Revision: G

LITE-ON DCC

RELEASE

BNS-OD-FC001/A4

Photocouplers LTV-814 824 844 (M, S, S-TA, S-TA1, S-TP) SERIES

1. DESCRIPTION

1.1 Features

- Current transfer ratio (CTR : MIN. 20% at $I_F = \pm 1\text{mA}$, $V_{CE} = 5\text{V}$)
- Response time (tr : TYP. $4\mu\text{s}$ at $V_{CE} = 2\text{V}$, $I_C = 2\text{mA}$, $R_L = 100\Omega$)
- AC input response
- Low collector dark current ($I_{CEO} : \text{MAX. } 10^{-7}\text{ A}$ at $V_{CE}=20\text{V}$)
- High input-output isolation voltage ($V_{iso} = 5,000\text{Vrms}$)
- Dual-in-line package :
 - LTV-814 : 1-Channel type
 - LTV-824 : 2-Channel type
 - LTV-844 : 4-Channel type
- Wide lead spacing package :
 - LTV-814M : 1-Channel type
 - LTV-824M : 2-Channel type
 - LTV-844M : 4-Channel type
- Surface mounting package :
 - LTV-814S : 1-Channel type
 - LTV-824S : 2-Channel type
 - LTV-844S : 4-Channel type
- Tape and reel packaging :
 - LTV-814S-TA, LTV-814S-TA1, LTV-814S-TP : 1-Channel type
 - LTV-824S-TA, LTV-824S-TA1 : 2-Channel type
- Safety approval
 - UL approved (No. E113898)
 - CSA approved (No. CA91533-1)
 - FIMKO approved (No. 193422-01)
 - VDE approved (No. 40015248)
- RoHS Compliance
- All materials be used in device are followed EU RoHS directive (No.2002/95/EC).
- ESD pass HBM 8000V/MM2000V
- MSL class1

1.2 Applications

- AC line monitor
- Unknown polarity DC sensor
- Telephone line interface

Photocouplers LTV-814 824 844 (M, S, S-TA, S-TA1, S-TP) SERIES

2. PACKAGE DIMENSIONS

2.1 LTV-814 :

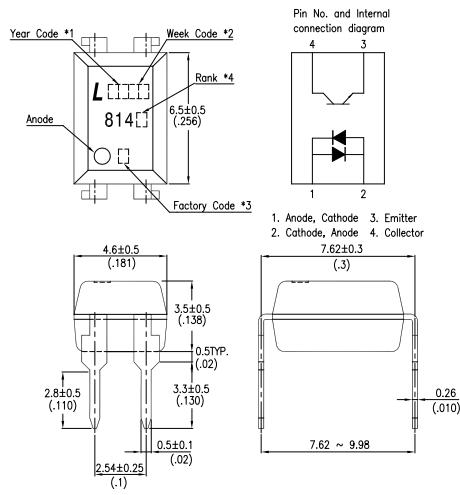

2.2 LTV-824 :

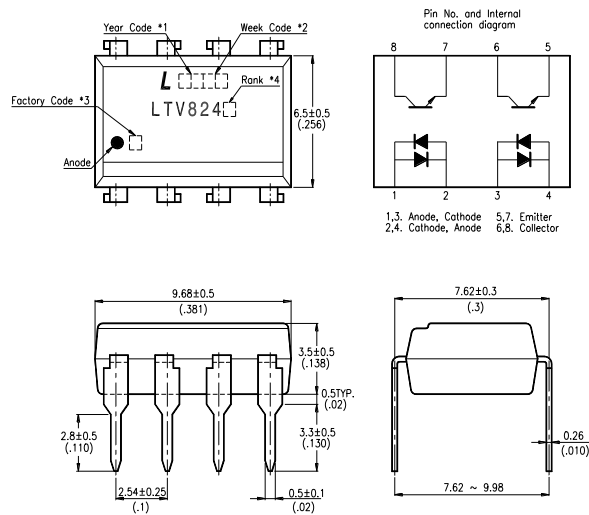

Notes :

1. Year date code.
2. 2-digit work week.
3. Factory identification mark shall be marked (Y: Thailand, W: China-CZ, X: China-TJ).
4. Rank shall be or shall not be marked.

Photocouplers LTV-814 824 844 (M, S, S-TA, S-TA1, S-TP) SERIES

2.3 LTV-844 :

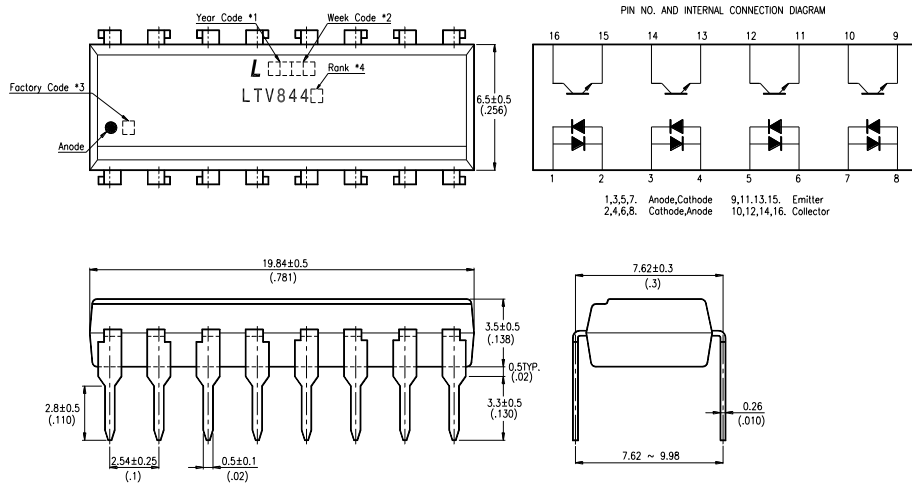

2.4 LTV-814M :

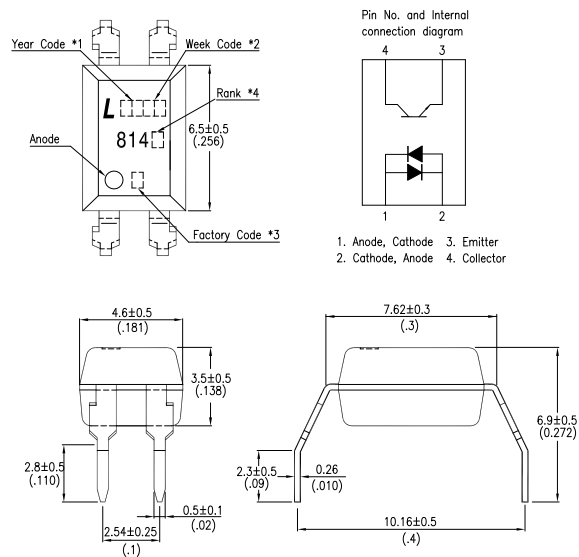

Notes :

1. Year date code.
2. 2-digit work week.
3. Factory identification mark shall be marked (Y: Thailand, W: China-CZ, X: China-TJ).
4. Rank shall be or shall not be marked.

Photocouplers LTV-814 824 844 (M, S, S-TA, S-TA1, S-TP) SERIES

2.5 LTV-824M :

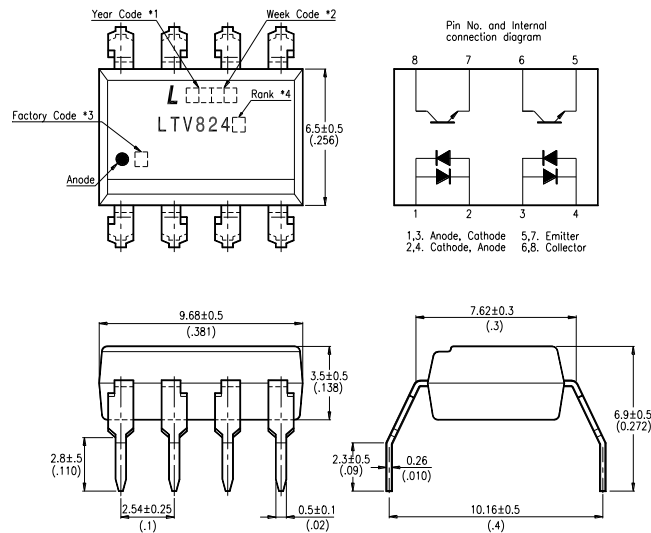

2.6 LTV-844M :

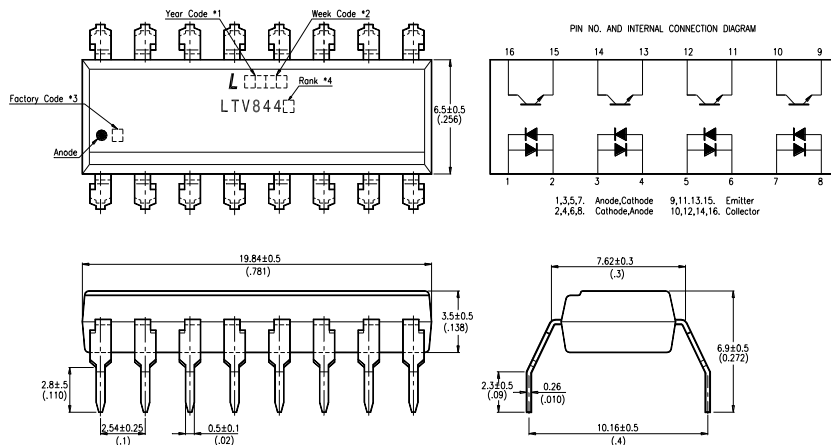

Notes :

1. Year date code.
2. 2-digit work week.
3. Factory identification mark shall be marked (Y: Thailand, W: China-CZ, X: China-TJ).
4. Rank shall be or shall not be marked.

Photocouplers LTV-814 824 844 (M, S, S-TA, S-TA1, S-TP) SERIES

2.7 LTV-814S :

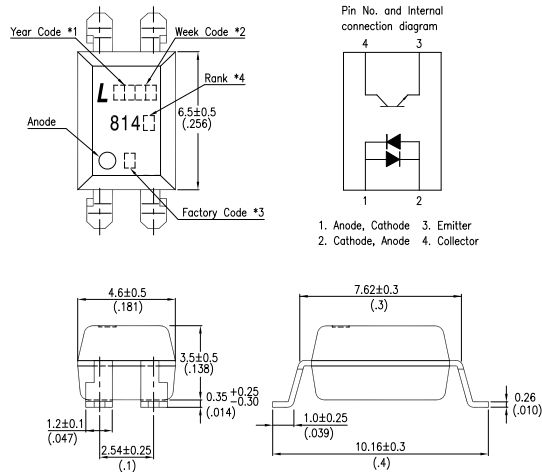

2.8 LTV-824S :

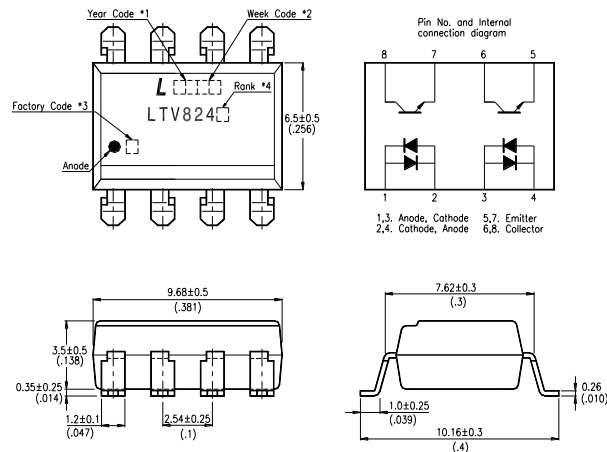

Notes :

1. Year date code.
2. 2-digit work week.
3. Factory identification mark shall be marked (Y: Thailand, W: China-CZ, X: China-TJ).
4. Rank shall be or shall not be marked.

Photocouplers LTV-814 824 844 (M, S, S-TA, S-TA1, S-TP) SERIES

2.9 LTV-844S :

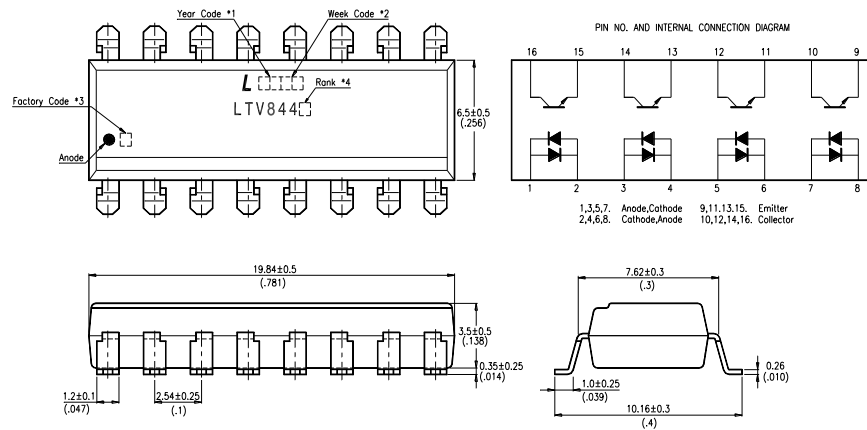

Notes :

1. Year date code.
2. 2-digit work week.
3. Factory identification mark shall be marked (Y: Thailand, W: China-CZ, X: China-TJ).
4. Rank shall be or shall not be marked.

Photocouplers LTV-814 824 844 (M, S, S-TA, S-TA1, S-TP) SERIES

3. TAPING DIMENSIONS

3.1 LTV-814S-TA :

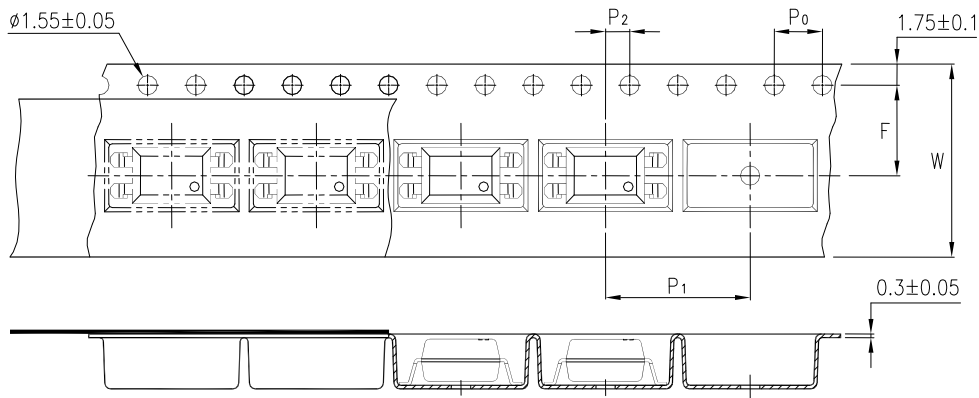

3.2 LTV-814S-TA1 :

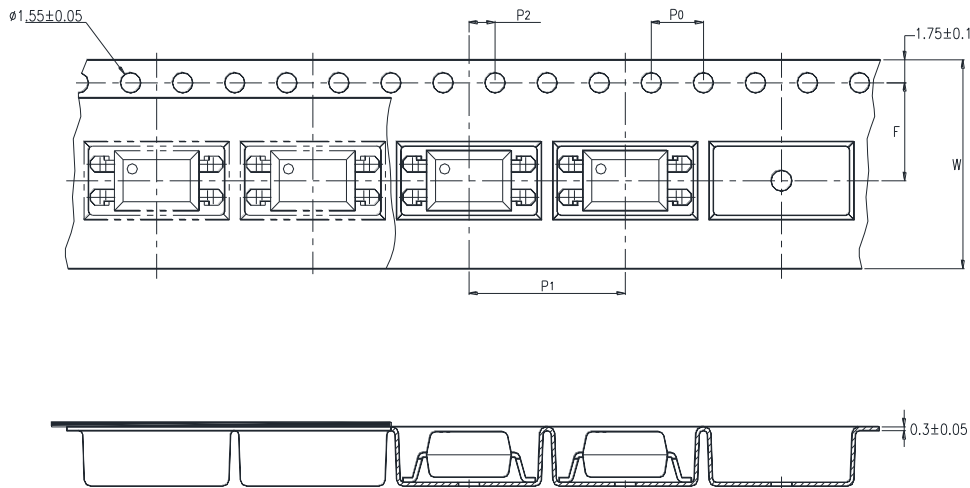

| Description | Symbol | Dimension in mm (inch) |
|--|--------|------------------------|
| Tape wide | W | 16 ± 0.3 (0.63) |
| Pitch of sprocket holes | P_0 | 4 ± 0.1 (0.15) |
| Distance of compartment | F | 7.5 ± 0.1 (0.295) |
| | P_2 | 2 ± 0.1 (0.079) |
| Distance of compartment to compartment | P_1 | 12 ± 0.1 (0.472) |

Photocouplers
LTV-814 824 844 (M, S, S-TA, S-TA1, S-TP) SERIES

3.3 LTV-814S-TP :

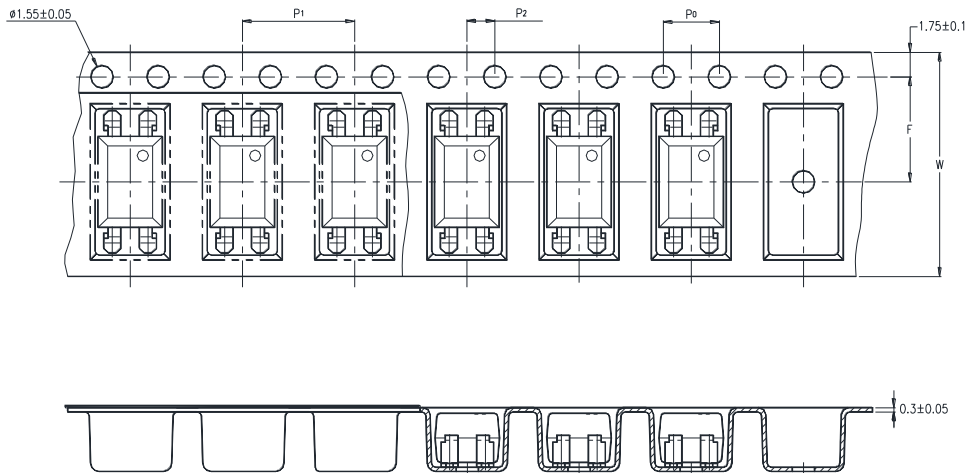

| Description | Symbol | Dimension in mm (inch) |
|--|----------------|------------------------|
| Tape wide | W | 16±0.3 (0.63) |
| Pitch of sprocket holes | P ₀ | 4±0.1 (0.15) |
| Distance of compartment | F | 7.5±0.1 (0.295) |
| | P ₂ | 2±0.1 (0.079) |
| Distance of compartment to compartment | P ₁ | 8±0.1 (0.316) |

Photocouplers LTV-814 824 844 (M, S, S-TA, S-TA1, S-TP) SERIES

3.4 LTV-824S-TA :

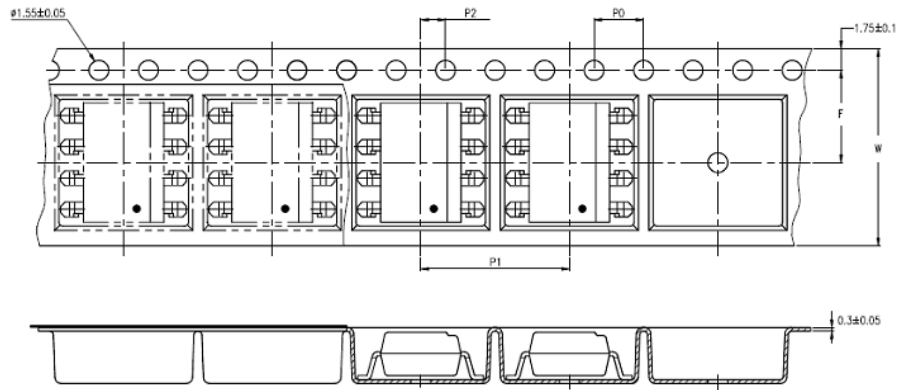

3.5 LTV-824S-TA1 :

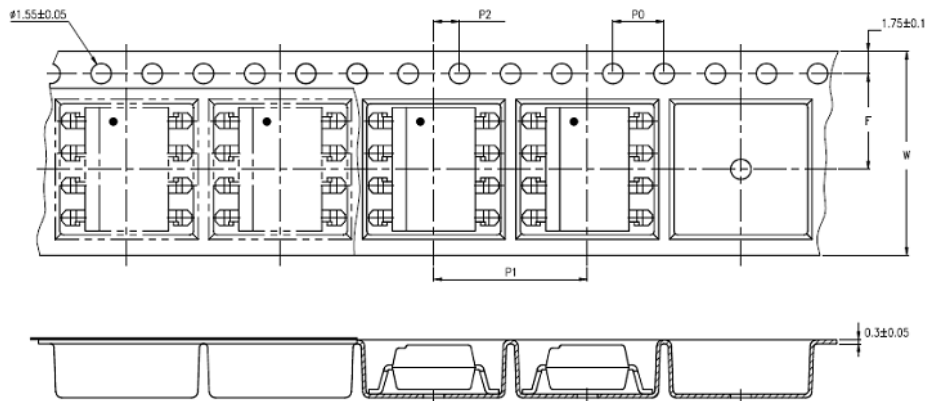

| Description | Symbol | Dimension in mm (inch) |
|--|--------|------------------------|
| Tape wide | W | 16 ± 0.3 (0.63) |
| Pitch of sprocket holes | P_0 | 4 ± 0.1 (0.15) |
| Distance of compartment | F | 7.5 ± 0.1 (0.295) |
| | P_2 | 2 ± 0.1 (0.079) |
| Distance of compartment to compartment | P_1 | 12 ± 0.1 (0.472) |

Photocouplers LTV-814 824 844 (M, S, S-TA, S-TA1, S-TP) SERIES

4. RATING AND CHARACTERISTICS

4.1 Absolute Maximum Ratings at Ta=25°C

| Parameter | | Symbol | Rating | Unit |
|---------------------------------------|-----------------------------|-----------|------------|-----------|
| Input | Forward Current | I_F | ± 50 | mA |
| | Power Dissipation | P | 70 | mW |
| Output | Collector - Emitter Voltage | V_{CEO} | 35 | V |
| | Emitter - Collector Voltage | V_{ECO} | 6 | V |
| | Collector Current | I_C | 50 | mA |
| | Collector Power Dissipation | P_C | 160 | mW |
| Total Power Dissipation | | P_{tot} | 200 | mW |
| *1 Isolation Voltage | | V_{iso} | 5000 | V_{rms} |
| Operating Temperature (LTV-824 / 844) | | T_{opr} | -30 ~ +100 | °C |
| Operating Temperature (LTV-814) | | T_{opr} | -30 ~ +110 | °C |
| Storage Temperature | | T_{stg} | -55 ~ +150 | °C |
| *2 Soldering Temperature | | T_{sol} | 260 | °C |

*1. AC For 1 Minute, R.H. = 40 ~ 60%

Isolation voltage shall be measured using the following method.

- (1) Short between anode and cathode on the primary side and between collector and emitter on the secondary side.
- (2) The isolation voltage tester with zero-cross circuit shall be used.
- (3) The waveform of applied voltage shall be a sine wave.

*2. For 10 Seconds

Photocouplers LTV-814 824 844 (M, S, S-TA, S-TA1, S-TP) SERIES

4.2 ELECTRICAL OPTICAL CHARACTERISTICS at Ta=25°C

| PARAMETER | | SYMBOL | MIN. | TYP. | MAX. | UNIT | CONDITIONS |
|--------------------------|--------------------------------------|----------------------|--------------------|--------------------|------|---------------|---|
| INPUT | Forward Voltage | V_F | — | 1.2 | 1.4 | V | $I_F = \pm 20\text{mA}$ |
| | Terminal Capacitance | C_t | — | 50 | 250 | pF | $V=0, f=1\text{KHz}$ |
| OUTPUT | Collector Dark Current | I_{CEO} | — | — | 100 | nA | $V_{CE}=20\text{V}, I_F=0$ |
| | Collector-Emitter Breakdown Voltage | $B_{V_{CEO}}$ | 35 | — | — | V | $I_C=0.1\text{mA}$ $I_F=0$ |
| | Emitter-Collector Breakdown Voltage | $B_{V_{ECO}}$ | 6 | — | — | V | $I_E=10\mu\text{A}$ $I_F=0$ |
| TRANSFER CHARACTERISTICS | Collector Current | I_C | 0.2 | — | 3 | mA | $I_F = \pm 1\text{mA}$ |
| | *Current Transfer Ratio | CTR | 20 | — | 300 | % | $V_{CE}=5\text{V}$ |
| | Collector-Emitter Saturation Voltage | $V_{CE(\text{sat})}$ | — | 0.1 | 0.2 | V | $I_F = \pm 20\text{mA}$ $I_C=1\text{mA}$ |
| | Isolation Resistance | Riso | 5×10^{10} | 1×10^{11} | — | Ω | DC500V 40 ~ 60% R.H. |
| | Floating Capacitance | C_f | — | 0.6 | 1 | pF | $V=0, f=1\text{MHz}$ |
| | Response Time (Rise) | t_r | — | 4 | 18 | μs | $V_{CE}=2\text{V}, I_C=2\text{mA}$ |
| | Response Time (Fall) | t_f | — | 3 | 18 | μs | $R_L=100\Omega$ |

$$* \text{CTR} = \frac{I_C}{I_F} \times 100\%$$

Photocouplers
LTV-814 824 844 (M, S, S-TA, S-TA1, S-TP) SERIES

4.3 RANK TABLE OF CURRENT TRANSFER RATIO CTR

| MODEL NO. | RANK MARK | CTR (%) |
|-------------|-------------------|-----------|
| LTV-814 | A | 50 ~ 150 |
| | B | 100 ~ 300 |
| | A or B or No mark | 20 ~ 300 |
| LTV-824/844 | No mark | 20 ~ 300 |

| | |
|-------------------|---|
| CONDITIONS | $I_F = \pm 1 \text{ mA}$ $V_{CE} = 5 \text{ V}$ $T_a = 25 \text{ }^\circ\text{C}$ |
|-------------------|---|

Photocouplers LTV-814 824 844 (M, S, S-TA, S-TA1, S-TP) SERIES

5. CHARACTERISTICS CURVES

Fig.1 Forward Current vs. Ambient Temperature

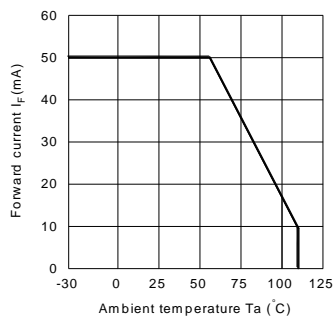

Fig.2 Collector Power Dissipation vs. Ambient Temperature

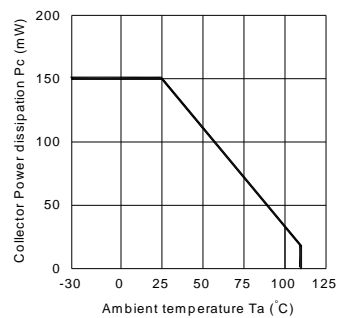

Fig.3 Collector-emitter Saturation Voltage vs. Forward Current

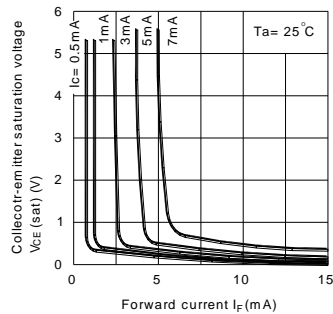

Fig.4 Forward Current vs. Forward Voltage

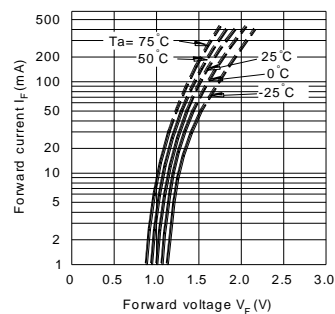

Fig.5 Current Transfer Ratio vs. Forward Current

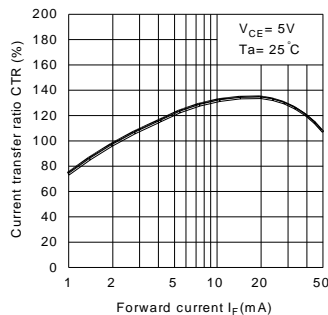
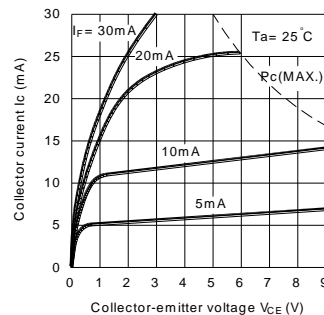

Fig.6 Collector Current vs. Collector-emitter Voltage



Photocouplers LTV-814 824 844 (M, S, S-TA, S-TA1, S-TP) SERIES

Fig.7 Relative Current Transfer Ratio vs. Ambient Temperature

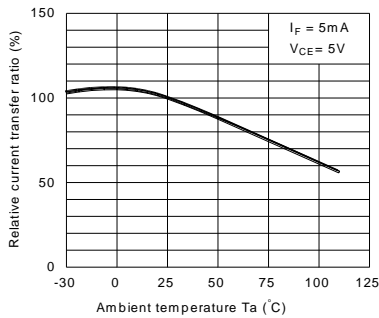

Fig.8 Collector-emitter Saturation Voltage vs. Ambient Temperature

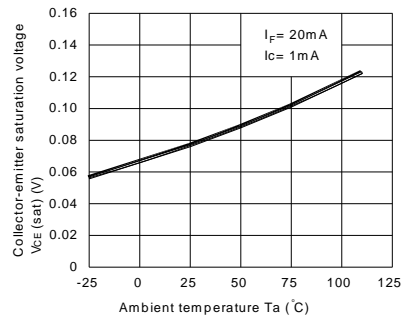

Fig.9 Collector Dark Current vs. Ambient Temperature

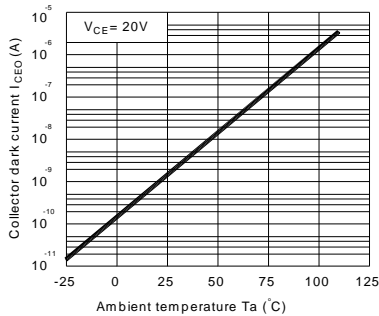

Fig.10 Response Time vs. Load Resistance

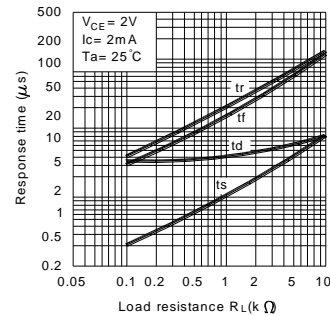
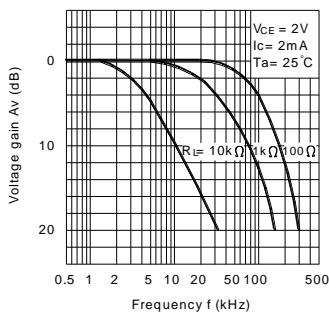
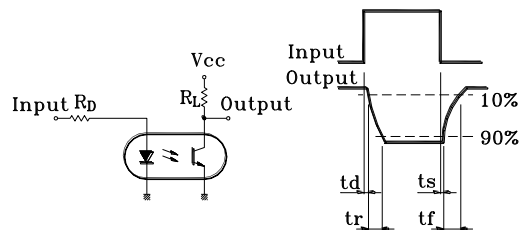

Fig.11 Frequency Response



Test Circuit for Response Time



Test Circuit for Frequency Response

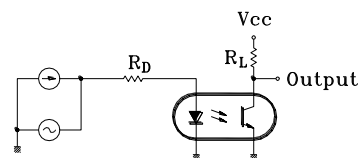

Photocouplers LTV-814 824 844 (M, S, S-TA, S-TA1, S-TP) SERIES

6. TEMPERATURE PROFILE OF SOLDERING

6.1 IR Reflow soldering (JEDEC-STD-020C compliant)

One time soldering reflow is recommended within the condition of temperature and time profile shown below. Do not solder more than three times.

| Profile item | Conditions |
|----------------------------------|----------------|
| Preheat | |
| - Temperature Min (T_{Smin}) | 150°C |
| - Temperature Max (T_{Smax}) | 200°C |
| - Time (min to max) (ts) | 90±30 sec |
| Soldering zone | |
| - Temperature (T_L) | 217°C |
| - Time (t_L) | 60 sec |
| Peak Temperature (T_P) | 260°C |
| Ramp-up rate | 3°C / sec max. |
| Ramp-down rate | 3~6°C / sec |

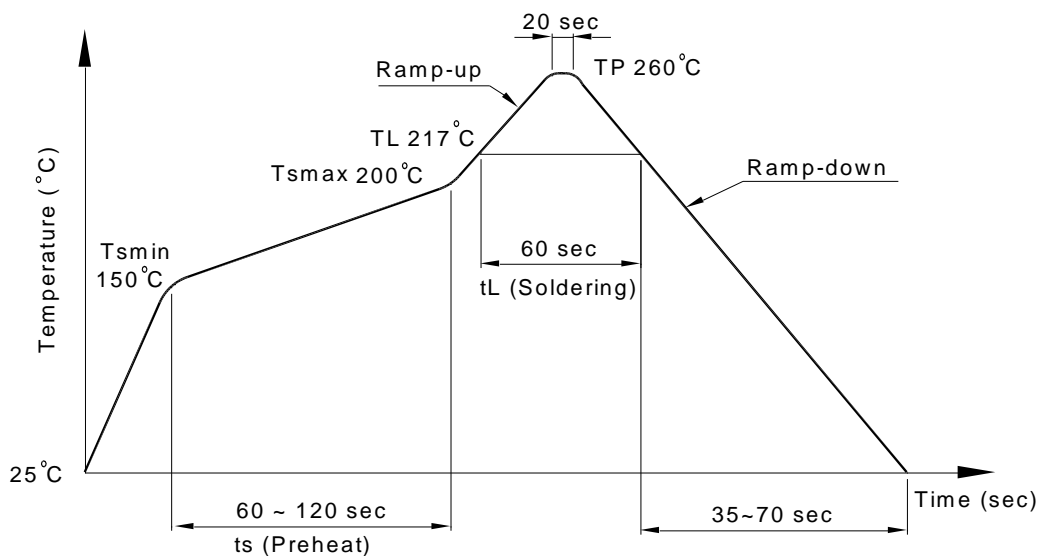

Photocouplers LTV-814 824 844 (M, S, S-TA, S-TA1, S-TP) SERIES

6.2 Wave soldering (JEDEC22A111 compliant)

One time soldering is recommended within the condition of temperature.

Temperature: $260 \pm 0 / -5^{\circ}\text{C}$

Time: 10 sec.

Preheat temperature: 25 to 140°C

Preheat time: 30 to 80 sec.

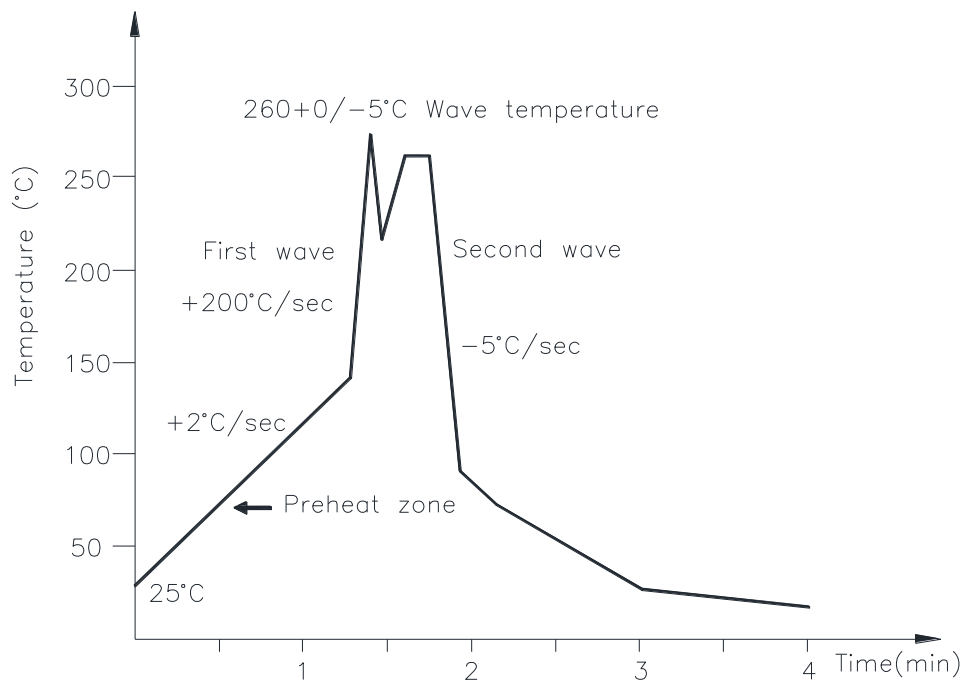

6.3 Hand soldering by soldering iron

Allow single lead soldering in every single process. One time soldering is recommended.

Temperature: $380 \pm 0 / -5^{\circ}\text{C}$

Time: 3 sec max.

Photocouplers
LTV-814 824 844 (M, S, S-TA, S-TA1, S-TP) SERIES

7. RRECOMMENDED FOOT PRINT PATTERNS (MOUNT PAD)

Unit: mm

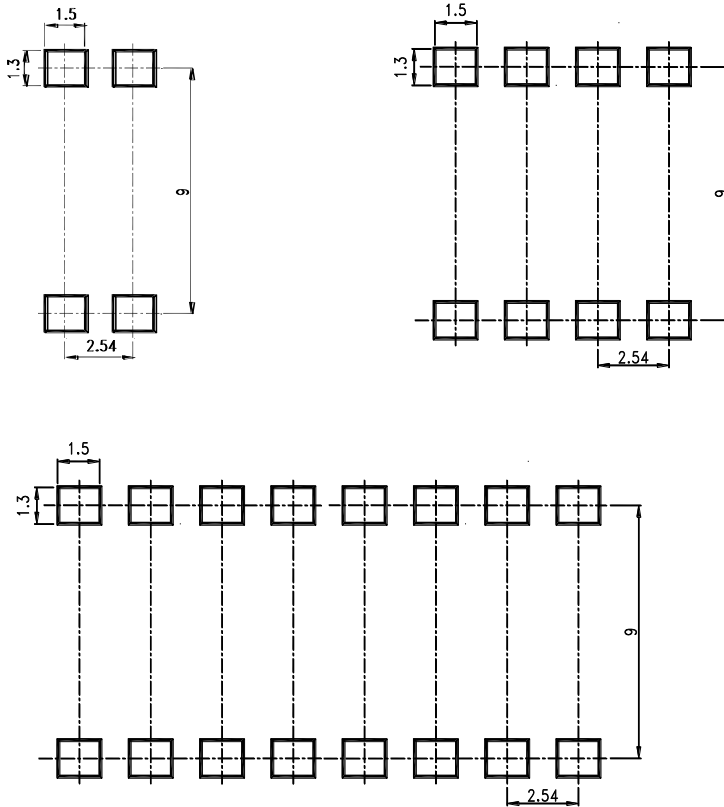

8. NAMING RULE

LTV-8XX(1)-(2)

DEVICE PART NUMBER

(1)= FORM TYPE (S, M or none)

(2)= TAPING TYPE (TA, TA1, TP or none)

Photocouplers LTV-814 824 844 (M, S, S-TA, S-TA1, S-TP) SERIES

9. Notes:

- LiteOn is continually improving the quality, reliability, function or design and LiteOn reserves the right to make changes without further notices.
- The products shown in this publication are designed for the general use in electronic applications such as office automation equipment, communications devices, audio/visual equipment, electrical application and instrumentation.
- For equipment/devices where high reliability or safety is required, such as space applications, nuclear power control equipment, medical equipment, etc, please contact our sales representatives.
- When requiring a device for any "specific" application, please contact our sales in advice.
- If there are any questions about the contents of this publication, please contact us at your convenience.
- The contents described herein are subject to change without prior notice.
- Immerge unit's body in solder paste is not recommended.