

# LXT9883/LXT9863

## Advanced 10/100 Unmanaged Repeater

### General Description

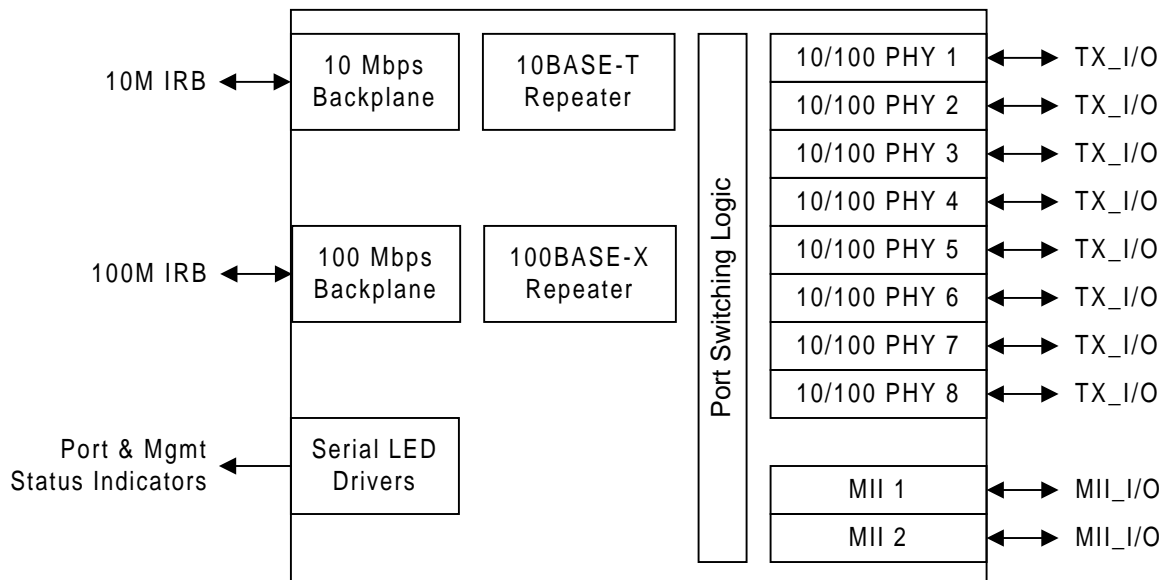
The LXT9883 is an advanced, 3.3V, 8-port 10/100 repeater. The LXT9883 is compatible with previous generations of Level One repeaters from the LXT980 and LXT918 families. Eight ports directly support 10BASE-TX/10BASE-T copper media. Two additional Media Independent Interface (MII) ports (10/100 Mbps selectable) connect to Media Access Controllers (MACs) for bridge/switch applications. The LXT9863 offers the same features and functionality in a six-port device. This data sheet uses the singular designation "LXT98x3" to refer to both devices.

The LXT98x3 provides auto-negotiation with parallel detection for the PHY ports. The LXT98x3 provides two internal repeater state machines—one operating at 10 Mbps and one at 100 Mbps. Once configured, the LXT98x3 automatically connects each port to the appropriate repeater. The LXT98x3 also provides two Inter-Repeater Backplanes (IRBs) for expansion — one operating at 10 Mbps and one at 100 Mbps. Up to 240 twisted-pair and MII ports can logically be combined into one repeater.

### Features

- Six or eight 10/100 ports with integrated twisted-pair PHYs including integrated filters.
- Two 10/100 MIIs for bridging.
- Independent segments for 10 and 100 Mbps operation.
- Cascadable Inter-Repeater Backplanes (IRBs), with option for 5V stacking compatibility.
- Integrated LED drivers with user-selectable modes.
- Available in 208-pin QFP package.
- Operating temperature range: 0-70°C, ambient.

### LXT98x3 Block Diagram



Refer to [www.level1.com](http://www.level1.com) for most current information.

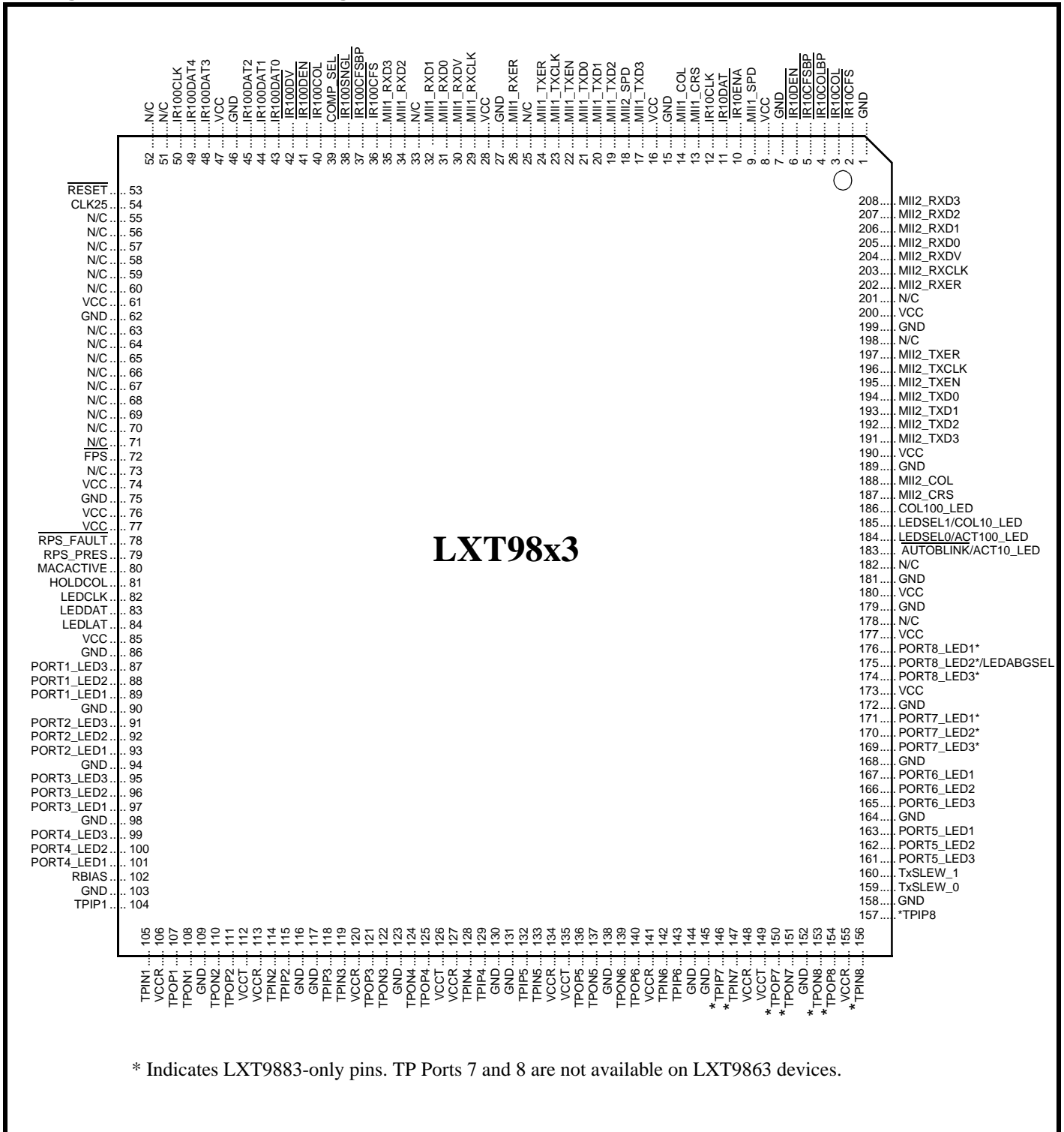


## TABLE OF CONTENTS

<b>Pin Assignments and Signal Descriptions</b> .....	<b>3</b>	Activity Graph LEDs .....	22
Pin Assignments .....	3	Direct Drive LEDs .....	23
MII #1 Signal Descriptions .....	4	LED Modes .....	23
MII #2 Signal Descriptions .....	5	LED Mode 1 .....	23
IRB Signal Descriptions .....	6	LED Mode 2 .....	25
Twisted-Pair Port Signal Descriptions .....	10	LED Mode 3 .....	26
LED Signal Descriptions .....	11	LED Mode 4 .....	27
Power Supply Signal Descriptions .....	12	<b>IRB Operation</b> .....	<b>28</b>
Miscellaneous Signal Descriptions .....	14	MAC IRB Access .....	28
<b>Functional Description</b> .....	<b>15</b>	LXT980 Device Compatibility .....	28
<b>Introduction</b> .....	<b>15</b>	<b>MII Port Operation</b> .....	<b>31</b>
<b>Port Configuration</b> .....	<b>16</b>	<b>Application Information</b> .....	<b>32</b>
Auto-Negotiation .....	16	<b>General Design Guidelines</b> .....	<b>32</b>
Link Establishment and Port Connection .....	16	Power and Ground .....	32
MII Port Configuration .....	16	Supply Filtering .....	32
<b>Interface Descriptions</b> .....	<b>16</b>	The RBIAS Pin .....	34
Twisted-Pair Interface .....	16	MII Terminations .....	34
Media Independent Interface (MII) .....	17	Twisted-Pair Interface .....	35
<b>Repeater Operation</b> .....	<b>18</b>	Magnetics Information .....	35
100 Mbps Repeater Operation .....	18	LED Circuits .....	37
10 Mbps Repeater Operation .....	18	Direct Drive LEDs .....	37
<b>Requirements</b> .....	<b>19</b>	LEDs Multiplexed with Configuration Inputs .....	37
Power .....	19	Serial Port LEDs .....	38
Clock .....	19	<b>Inter-Repeater Backplane Compatibility</b> .....	<b>39</b>
Bias Current .....	35	Local Backplane - 3.3V Only .....	39
Reset .....	19	Stack Backplane - 3.3V or 5.0V .....	39
IRB Bus Pull-Ups .....	19	<b>Test Specifications</b> .....	<b>42</b>
<b>LED Operation</b> .....	<b>20</b>	<b>Mechanical Specifications</b> .....	<b>55</b>
LEDs at Start-Up .....	20		
Serial LEDs .....	20		
LED Event Stretching .....	20		
Serial LED Interface .....	20		
Serial Shifting .....	20		
Serial LED Signals .....	21		

# PIN ASSIGNMENTS AND SIGNAL DESCRIPTIONS

Figure 1: LXT9883 Pin Assignments



\* Indicates LXT9883-only pins. TP Ports 7 and 8 are not available on LXT9863 devices.

**Table 1: MII #1 Signal Descriptions**

Pin	Symbol	Type <sup>1, 2</sup>	Description
9	MII1_SPD	I PU	<b>Speed Select - MII 1.</b> This signal is sensed at power up, hardware reset, and software reset. Selects operating speed of the respective MII (MAC) interface. High = 100 Mbps. Low = 10 Mbps.
31	MII1_RXD0	O	<b>Receive Data - MII 1.</b> The LXT98x3 transmits received data to the controller on these outputs. Data is driven on the falling edge of MII1_RXCLK.
32	MII1_RXD1		
34	MII1_RXD2		
35	MII1_RXD3		
30	MII1_RXDV	O	<b>Receive Data Valid - MII 1.</b> Active High signal, synchronous to MII1_RXCLK, indicates valid data on MII1_RXD<3:0>.
29	MII1_RXCLK	O	<b>Receive Clock - MII 1.</b> MII receive clock for expansion port. This is a 2.5 or 25 MHz clock derived from the CLK25 input (refer to <a href="#">Table 7 on page 14</a> ).
26	MII1_RXER	O	<b>Receive Error - MII 1.</b> Active High signal, synchronous to MII1_RXCLK, indicates invalid data on MII1_RXD<3:0>.
24	MII1_TXER	I	<b>Transmit Error - MII 1.</b> MII1_TXER is a 100M-only signal. The MAC asserts this input when an error has occurred in the transmit data stream. The LXT98x3 responds by sending 'Invalid Code Symbols' on the line.
23	MII1_TXCLK	O	<b>Transmit Clock - MII 1.</b> This is a 2.5 or 25 MHz clock derived from the CLK25 input (refer to <a href="#">Table 7 on page 14</a> ).
22	MII1_TXEN	I	<b>Transmit Enable - MII 1.</b> External controllers drive this input High to indicate data is transmitted on the MII1_TXD<3:0> pins. Ground this input if unused.
21	MII1_TXD0	I	<b>Transmit Data - MII 1.</b> External controllers use these inputs to transmit data to the LXT98x3. The LXT98x3 samples MII1_TXD<3:0> on the rising edge of MII1_TXCLK, when MII1_TXEN is High.
20	MII1_TXD1		
19	MII1_TXD2		
17	MII1_TXD3		
14	MII1_COL	O	<b>Collision - MII 1.</b> The LXT98x3 drives this signal High to indicate a collision occurred.
13	MII1_CRS	O	<b>Carrier Sense - MII 1.</b> Active High signal indicates LXT98x3 is transmitting or receiving.

1. I = Input, O = Output, I/O = Input/Output, D = Digital, A = Analog, AI = Analog Input, A I/O = Analog Input/Output, OD = Open Drain, OS = Open Source, PD = Pull Down, PU = Pull Up.  
NC = No Clamp. Pad does not clamp input in the absence of power.

2. Pins are 5V tolerant, unless indicated.

Table 2: MII #2 Signal Descriptions

Pin	Symbol	Type <sup>1, 2</sup>	Description
18	MII2_SPD	I PU	<b>Speed Select - MII 2.</b> This signal is sensed at power up, hardware reset, and software reset. Selects operating speed of the respective MII (MAC) interface. High = 100 Mbps. Low = 10 Mbps.
205 206 207 208	MII2_RXD0 MII2_RXD1 MII2_RXD2 MII2_RXD3	O	<b>Receive Data - MII 2.</b> The LXT98x3 transmits received data to the controller on these outputs. Data is driven on the falling edge of MII2_RXCLK.
204	MII2_RXDV	O	<b>Receive Data Valid - MII 2.</b> Active High signal, synchronous to MII2_RXCLK, indicates valid data on MII2_RXD<3:0>.
203	MII2_RXCLK	O	<b>Receive Clock - MII 2.</b> MII receive clock for expansion port. This is a 2.5 or 25 MHz clock derived from the CLK25 input (refer to <a href="#">Table 7 on page 14</a> ).
202	MII2_RXER	O	<b>Receive Error - MII 2.</b> Active High signal, synchronous to MII2_RXCLK, indicates invalid data on MII2_RXD<3:0>.
197	MII2_TXER	I	<b>Transmit Error - MII 2.</b> MII2_TXER is a 100M-only signal. The MAC asserts this input when errors occurs in the transmit data stream. The LXT98x3 sends 'Invalid Code Symbols' on the line.
196	MII2_TXCLK	O	<b>Transmit Clock - MII 2.</b> This is a 2.5 or 25 MHz clock derived from the CLK25 input (refer to <a href="#">Table 7 on page 14</a> ).
195	MII2_TXEN	I	<b>Transmit Enable - MII 2.</b> External controllers drive this input High to indicate data is transmitted on the MII2_TXD<3:0> pins. Ground this input if unused.
194 193 192 191	MII2_TXD0 MII2_TXD1 MII2_TXD2 MII2_TXD3	I	<b>Transmit Data - MII 2.</b> External controllers use these inputs to transmit data to the LXT98x3. The LXT98x3 samples MII2_TXD<3:0> on the rising edge of MII2_TXCLK, when MII2_TXEN is High.
188	MII2_COL	O	<b>Collision - MII 2.</b> The LXT98x3 drives this signal High to indicate a collision occurred.
187	MII2_CRS	O	<b>Carrier Sense - MII 2.</b> Active High signal indicates LXT98x3 is transmitting or receiving.
<p>1. I = Input, O = Output, I/O = Input/Output, D = Digital, A = Analog, AI = Analog Input, A I/O = Analog Input/Output, OD = Open Drain, OS = Open Source, PD = Pull Down, PU = Pull Up. NC = No Clamp. Pad does not clamp input in the absence of power.</p> <p>2. Pins are 5V tolerant, unless indicated.</p>			

Table 3: Inter-Repeater Backplane Signal Descriptions

Pin	Symbol	Type <sup>1, 2</sup>	Description
<b>Common IRB Signals</b>			
39	COMP_SEL	AI	<b>Compatibility Mode Select.</b> 3.3V on this pin causes the $\overline{\text{IRCFSBP}}$ signals to operate in 3.3V only mode. 5V on this pin causes the $\overline{\text{IR100CFSBP}}$ or $\overline{\text{IR10CFSBP}}$ signals to operate in 5V backwards compatibility mode with LXT98x devices.
<b>100 Mbps IRB Signals</b>			
36	$\overline{\text{IR100CFS}}^3$	A I/O OD	<b>100 Mbps IRB Collision Force Sense.</b> A three-level signal that determines number of active ports on the “logical” repeater. High level (3.3V) indicates no ports active; Mid level (approx. 1.6V) indicates one port active; Low level (0V) indicates more than one port active, resulting in a collision. This signal requires a 215 $\Omega$ pull-up resistor, and connects between ICs on the same board.
37	$\overline{\text{IR100CFSBP}}$	A I/O OD	<b>100 Mbps IRB Collision Force Sense - Backplane.</b> This three-level signal functions the same as $\overline{\text{IR100CFS}}$ ; however, it connects between ICs with FPS = 0, on different boards. $\overline{\text{IR100CFSBP}}$ requires a single 91 $\Omega$ pull-up resistor in each stack. This signal can be set in either 5V or 3.3V modes by the COMP_SEL pin.
38	$\overline{\text{IR100SNGL}}$	I/O Schmitt PU	<b>100 Mbps Single Driver State.</b> This active Low signal is asserted by the device with FPS = 0 when a packet is received from one or more ports. Do not connect this signal between boards.
40	$\overline{\text{IR100COL}}$	I/O Schmitt PU	<b>100 Mbps Multiple Driver State.</b> This active Low signal is asserted by the device with FPS = 0 when a packet is being received from more than one port (collision). Do not connect this signal between boards.
41	$\overline{\text{IR100DEN}}$	O OD	<b>100 Mbps IRB Driver Enable.</b> This output provides directional control for an external bidirectional transceiver (74LVT245) used to buffer the 100 Mbps IRB in multi-board applications. It must be pulled up by a 330 $\Omega$ resistor. When there are multiple devices on one board, tie all $\overline{\text{IR100DEN}}$ outputs together. If $\overline{\text{IR100DEN}}$ is tied directly to the DIR pin on a 74LVT245, attach the on-board $\overline{\text{IR100DAT}}$ , $\overline{\text{IR100CLK}}$ , and $\overline{\text{IR100DV}}$ signals to the “B” side of the 74LVT245, and connect the off-board signals to the “A” side of the 74LVT245.
42	$\overline{\text{IR100DV}}$	I/O Schmitt OD PU	<b>100 Mbps IRB Data Valid.</b> This active Low signal indicates port activity on the repeater. $\overline{\text{IR100DV}}$ frames the clock and data of the packet on the backplane. This signal requires a 300 $\Omega$ pull-up resistor.
<p>1. I = Input, O = Output, I/O = Input/Output, D = Digital, AI = Analog Input, A I/O = Analog Input/Output, OD = Open Drain, OS = Open Source, PD = Pull Down, PU = Pull Up. Even if the IRB is not used, required pull-up resistors must be installed as listed above. NC = No Clamp. Pad does not clamp input in the absence of power.</p> <p>2. Pins are 5V tolerant, unless indicated.</p> <p>3. <math>\overline{\text{IR100CFS}}</math> is <b>not</b> 5V tolerant.</p> <p>4. <math>\overline{\text{IR10CFS}}</math> is <b>not</b> 5V tolerant.</p>			

**Table 3: Inter-Repeater Backplane Signal Descriptions** – continued

Pin	Symbol	Type <sup>1, 2</sup>	Description
43	IR100DAT0	I/O	<b>100 Mbps IRB Data.</b> These bidirectional signals carry 5-bit data on the 100 Mbps IRB. Data is driven on the falling edge and sampled on the rising edge of IR100CLK. Buffer these signals between boards.
44	IR100DAT1	Tri-state	
45	IR100DAT2	Schmitt PU	
48	IR100DAT3		
49	IR100DAT4		
50	IR100CLK	I/O Tri-state Schmitt PD	<b>100 Mbps IRB Clock.</b> This bidirectional, non-continuous, 25 MHz clock is recovered from received network traffic. Schmitt triggering is used to increase noise immunity. This signal must be pulled to VCC when idle. One 1 k $\Omega$ pull-up resistor on both sides of a 74LVT245 buffer is recommended.
<p>1. I = Input, O = Output, I/O = Input/Output, D = Digital, AI = Analog Input, A I/O = Analog Input/Output, OD = Open Drain, OS = Open Source, PD = Pull Down, PU = Pull Up. Even if the IRB is not used, required pull-up resistors must be installed as listed above. NC = No Clamp. Pad does not clamp input in the absence of power.</p> <p>2. Pins are 5V tolerant, unless indicated.</p> <p>3. <u>IR100CFS</u> is <b>not</b> 5V tolerant.</p> <p>4. <u>IR10CFS</u> is <b>not</b> 5V tolerant.</p>			

Table 3: Inter-Repeater Backplane Signal Descriptions – continued

Pin	Symbol	Type <sup>1, 2</sup>	Description
<b>10 Mbps IRB Signals</b>			
11	IR10DAT	I/O OD PD	<b>10 Mbps IRB Data.</b> This bidirectional signal carries data on the 10 Mbps IRB. Data is driven and sampled on the rising edge of the corresponding IRCLK. This signal must be pulled High by a 330Ω resistor. Buffer this signal between boards.
12	IR10CLK	I/O Tri-state Schmitt PD	<b>10 Mbps IRB Clock.</b> This bidirectional, non-continuous, 10 MHz clock is recovered from received network traffic. During idle periods, the output is high-impedance. Schmitt triggering is used to increase noise immunity.
6	$\overline{\text{IR10DEN}}$	O OD	<b>10 Mbps IRB Driver Enable.</b> This output provides directional control for an external bidirectional transceiver (74LVT245) used to buffer the IRBs in multi-board applications. It must be pulled up by a 330Ω resistor. When there are multiple devices on one board, tie all $\overline{\text{IR10DEN}}$ outputs together. If $\overline{\text{IR10DEN}}$ is tied directly to the DIR pin on a 74LVT245, attach the on-board IR10DAT, IR10CLK and $\overline{\text{IR10ENA}}$ signals to the “B” side of the 74LVT245, and connect the off-board signals to the “A” side of the 74LVT245.
10	$\overline{\text{IR10ENA}}$	I/O OD PU	<b>10 Mbps IRB Enable.</b> This active Low output indicates carrier presence on the IRB. A 330Ω pull-up resistor is required to pull the $\overline{\text{IR10ENA}}$ output High when the IRB is idle. When there are multiple devices, tie all $\overline{\text{IR10ENA}}$ outputs together. Buffer these signals between boards.
3	$\overline{\text{IR10COL}}$	I/O OD PU	<b>10 Mbps IRB Collision.</b> This output is driven Low to indicate a collision occurred on the 10 Mbps segment. A 330Ω resistor is required on each board to pull this signal High when there is no collision. Do not connect between boards and do not buffer.
4	$\overline{\text{IR10COLBP}}$	I/O OD	<b>10 Mbps IRB Collision - Backplane.</b> This active Low output has the same function as $\overline{\text{IR10COL}}$ , but is used between boards. Attach this signal only from the device with $\overline{\text{FPS}} = 0$ to the backplane or connector, <i>without buffering</i> . The output must be pulled up by one 330Ω resistor per stack.
2	$\overline{\text{IR10CFS}}$ <sup>4</sup>	A, I/O OD	<b>10 Mbps IRB Collision Force Sense.</b> This three-state analog signal indicates transmit collision when driven Low. $\overline{\text{IR10CFS}}$ requires a 215Ω, 1% pull-up resistor. Do not connect this signal between boards and do not buffer.
<p>1. I = Input, O = Output, I/O = Input/Output, D = Digital, AI = Analog Input, A I/O = Analog Input/Output, OD = Open Drain, OS = Open Source, PD = Pull Down, PU = Pull Up. Even if the IRB is not used, required pull-up resistors must be installed as listed above. NC = No Clamp. Pad does not clamp input in the absence of power.</p> <p>2. Pins are 5V tolerant, unless indicated.</p> <p>3. <math>\overline{\text{IR100CFS}}</math> is <b>not</b> 5V tolerant.</p> <p>4. <math>\overline{\text{IR10CFS}}</math> is <b>not</b> 5V tolerant.</p>			



**Table 3: Inter-Repeater Backplane Signal Descriptions** – continued

Pin	Symbol	Type <sup>1, 2</sup>	Description
5	$\overline{\text{IR10CFSBP}}$	A I/O OD	<b>10 Mbps IRB Collision Force Sense - Backplane.</b> Functions the same as $\overline{\text{IR10CFS}}$ , but connects between boards. Attach this signal only from the device with $\overline{\text{FPS}} = 0$ to the backplane or connector, <i>without buffering</i> . This signal requires one 330 $\Omega$ , 1% pull-up resistor per stack. This signal can be set for 5V or 3.3V modes by the COMP_SEL pin.
80	MACACTIVE	I PD	<b>MAC Active.</b> Active High input allows external ASICs to participate in 10 Mbps IRB. Driving data onto the IRB requires the external ASIC assert MACACTIVE High for one clock cycle, then assert $\overline{\text{IR10ENA}}$ Low. ASIC monitors $\overline{\text{IR10COL}}$ (active Low) for collision. By using MACACTIVE, the repeater—not the MAC—drives the three-level $\overline{\text{IR10CFS}}$ pin.
81	HOLDCOL	I/O PD	<b>Hold Collision for 10 Mbps mode.</b> This active High signal is driven by the device with $\overline{\text{FPS}} = 0$ to extend a non-local transmit collision to other devices on the same board. Do not attach the HOLDCOL signals from different boards together.
<p>1. I = Input, O = Output, I/O = Input/Output, D = Digital, AI = Analog Input, A I/O = Analog Input/Output, OD = Open Drain, OS = Open Source, PD = Pull Down, PU = Pull Up. Even if the IRB is not used, required pull-up resistors must be installed as listed above. NC = No Clamp. Pad does not clamp input in the absence of power.</p> <p>2. Pins are 5V tolerant, unless indicated.</p> <p>3. <math>\overline{\text{IR100CFS}}</math> is <b>not</b> 5V tolerant.</p> <p>4. <math>\overline{\text{IR10CFS}}</math> is <b>not</b> 5V tolerant.</p>			

**Table 4: Twisted-Pair Port Signal Descriptions**

Pin	Symbol	Type <sup>1</sup>	Description															
107, 108 111, 110 121, 122 125, 124 136, 137 140, 139 150, 151 154, 153	TPOP1, TPON1 TPOP2, TPON2 TPOP3, TPON3 TPOP4, TPON4 TPOP5, TPON5 TPOP6, TPON6 TPOP7, TPON7 TPOP8, TPON8	AO	<b>Twisted-Pair Outputs - Ports 1 through 8.</b> These pins are the positive and negative outputs from the respective ports' twisted-pair line drivers. For unused ports, these pins can be left open.															
104, 105 115, 114 118, 119 129, 128 132, 133 143, 142 146, 147 157, 156	TPIP1, TPIN1 TPIP2, TPIN2 TPIP3, TPIN3 TPIP4, TPIN4 TPIP5, TPIN5 TPIP6, TPIN6 TPIP7, TPIN7 TPIP8, TPIN8	AI	<b>Twisted-Pair Inputs - Ports 1 through 8.</b> These pins are the positive and negative inputs to the respective ports' twisted-pair receivers. For unused ports, tie together with 100Ω resistors and float.															
160 159	TxSLEW_1 TxSLEW_0	I PD	<p><b>Tx Output Slew Controls 0 and 1.</b> These pins select the TX output slew rate (rise and fall time) as follows:</p> <table border="1"> <thead> <tr> <th>TxSLEW_1</th> <th>TxSLEW_0</th> <th>Slew Rate (Rise and Fall Time)</th> </tr> </thead> <tbody> <tr> <td>0</td> <td>0</td> <td>2.5 ns</td> </tr> <tr> <td>0</td> <td>1</td> <td>3.1 ns</td> </tr> <tr> <td>1</td> <td>0</td> <td>3.7 ns</td> </tr> <tr> <td>1</td> <td>1</td> <td>4.3 ns</td> </tr> </tbody> </table>	TxSLEW_1	TxSLEW_0	Slew Rate (Rise and Fall Time)	0	0	2.5 ns	0	1	3.1 ns	1	0	3.7 ns	1	1	4.3 ns
TxSLEW_1	TxSLEW_0	Slew Rate (Rise and Fall Time)																
0	0	2.5 ns																
0	1	3.1 ns																
1	0	3.7 ns																
1	1	4.3 ns																
<p>1. I = Input, O = Output, I/O = Input/Output, D = Digital, A = Analog, AI = Analog Input, AO = Analog Output, A I/O = Analog Input/Output, OD = Open Drain, OS = Open Source, PD = Pull Down, PU = Pull Up, NC = No Clamp. Pad does not clamp input in the absence of power.</p>																		

Table 5: LED Signal Descriptions

Pin	Symbol	Type <sup>1, 2</sup>	Description
184	LEDSEL0	I <sup>3</sup>	<b>LED Mode Select</b> - Input. See Note 3 in footer below. 00 = Mode 1, 01 = Mode 2, 10 = Mode 3, 11 = Mode 4 These pins are shared with the LEDACT100, LEDCOL10 outputs.
185	LEDSEL1	O - OD/OS	
175	LEDABGSEL	I <sup>3</sup> O - OD/OS	<b>LED Activity Bar Graph Mode Select</b> - Input. See Note 2 in footer below. 0 = Base-10 Mode, 1 = Base-2 Mode Refer to “Activity Graph LEDs” on page 59. This pin is shared with the Port8_LED2 output.
183	AUTOBLINK	I <sup>3</sup> O - OD/OS	<b>LED Blink Mode Select</b> - Input. See Note 3 in footer below. 0 = Auto blink on, 1 = Auto blink off This pin is shared with the LEDACT100, LEDCOL10 outputs.
83	LEDDAT	O	<b>LED Data.</b> Serial data stream that is shifted into external Serial-to-Parallel LED drivers. See “Serial LED Interface” on page 20.
84	LEDLAT	O	<b>LED Latch.</b> Parallel load clock for external Serial-to-Parallel LED drivers. See “Serial LED Interface” on page 20.
82	LEDCLK	O	<b>LED Clock.</b> Serial data stream clock for external Serial-to-Parallel LED drivers. See “Serial LED Interface” on page 20.
176	PORT8_LED1	O OD	<b>LED Driver 1 - Ports 1 through 8.</b> Programmable LED driver. Active Low. See “Direct Drive LEDs” on page 23.  Port8_LED1 must be pulled High via a 100–500 kΩ resistor if LED circuit not used.
171	PORT7_LED1		
167	PORT6_LED1		
163	PORT5_LED1		
101	PORT4_LED1		
97	PORT3_LED1		
93	PORT2_LED1		
89	PORT1_LED1		
175	PORT8_LED2	O OD	<b>LED Driver 2 - Ports 1 through 8.</b> Programmable LED driver. Active Low. See “Direct Drive LEDs” on page 23.  The Port8_LED2 pin is shared with the LEDABGSEL configuration input.
170	PORT7_LED2		
166	PORT6_LED2		
162	PORT5_LED2		
100	PORT4_LED2		
96	PORT3_LED2		
92	PORT2_LED2		
88	PORT1_LED2		

1. I = Input, O = Output, I/O = Input/Output, D = Digital, A = Analog, AI = Analog Input, A I/O = Analog Input/Output, OD = Open Drain, OS = Open Source, PD = Pull Down, PU = Pull Up. Even if the IRB is not used, required pull-up resistors must be installed as listed above. NC = No Clamp. Pad does not clamp input in the absence of power.

2. Pins are 5V tolerant, unless indicated.

3. Input must be static; Refer to “LED Pins Multiplexed with Configuration Inputs” on page 37 for information on pin use.

**Table 5: LED Signal Descriptions – continued**

Pin	Symbol	Type <sup>1, 2</sup>	Description
174 169 165 161 99 95 91 87	PORT8_LED3 PORT7_LED3 PORT6_LED3 PORT5_LED3 PORT4_LED3 PORT3_LED3 PORT2_LED3 PORT1_LED3	O OD	<b>LED Driver 3 - Ports 1 through 8.</b> Programmable LED driver. Active Low. See “Direct Drive LEDs” on page 23.  Port8_LED3 must be pulled High via a 100–500 kΩ resistor if LED circuit not used.
185	COL10_LED	I O - OD/OS	<b>10M Collision LED Driver.</b> Active output indicates collision on 10M segment. This pin is shared with the LEDSEL1 configuration input.
186	COL100_LED	I O - OD/OS	<b>100M Collision LED Driver.</b> Active output indicates collision on 100M segment.
183	ACT10_LED	I O - OD/OS	<b>10M Activity LED Driver.</b> Active output indicates activity on 10M segment. This pin is shared with the AUTOBLINK configuration input (refer to Note 3 below).
184	ACT100_LED	I O - OD/OS	<b>100M Activity LED Driver.</b> Active output indicates activity on 100M segment. This pin is shared with the LEDSEL0 configuration input (refer to Note 3 below).
<p>1. I = Input, O = Output, I/O = Input/Output, D = Digital, A = Analog, AI = Analog Input, A I/O = Analog Input/Output, OD = Open Drain, OS = Open Source, PD = Pull Down, PU = Pull Up. Even if the IRB is not used, required pull-up resistors must be installed as listed above. NC = No Clamp. Pad does not clamp input in the absence of power.</p> <p>2. Pins are 5V tolerant, unless indicated.</p> <p>3. Input must be static; Refer to “LED Pins Multiplexed with Configuration Inputs” on page 37 for information on pin use.</p>			

**Table 6: Power Supply and Indication Signal Descriptions**

Pin	Symbol	Type <sup>1, 2</sup>	Description
8, 16, 28, 47, 61, 74, 76, 85, 173, 177, 180, 190, 200	VCC	-	<b>Power Supply Inputs.</b> Each of these pins must be connected to a common +3.3 VDC power supply. A de-coupling capacitor to digital ground should be supplied for every one of these pins.
106, 113, 120, 127, 134, 141, 148, 155	VCCR	-	<b>Analog Supply Inputs - Receive.</b> Each of these pins must be connected to a common +3.3 VDC power supply. A de-coupling capacitor to GND should be supplied for every one of these pins. Use ferrite beads to create a separate analog VCC plane.
112, 126, 135, 149	VCCT	-	<b>Analog Supply Inputs - Transmit.</b> Each of these pins must be connected to a common +3.3 VDC power supply. A de-coupling capacitor to GND should be supplied for every one of these pins. Use ferrite beads to create a separate analog VCC plane.
<p>1. I = Input, O = Output, I/O = Input/Output, D = Digital, A = Analog, AI = Analog Input, A I/O = Analog Input/Output, OD = Open Drain, OS = Open Source, PD = Pull Down, PU = Pull Up. NC = No Clamp. Pad does not clamp input in the absence of power.</p> <p>2. Pins are 5V tolerant, unless indicated.</p>			

**Table 6: Power Supply and Indication Signal Descriptions – continued**

Pin	Symbol	Type <sup>1, 2</sup>	Description
1, 7, 15, 27, 46, 62, 75, 77, 86, 90, 94, 98, 103, 109, 116, 117, 123, 130, 131, 138, 144, 145, 152, 158, 164, 168, 172, 179, 181, 189, 199	GND	-	<b>Ground.</b> Connect each of these pins to system ground plane.
102	RBIAS	A	<b>RBIAS.</b> Used to provide bias current for internal circuitry. The 100 $\mu$ A bias current is provided through an external 22.1 k $\Omega$ , 1% resistor to GND.
79	RPS_PRES	I PD	<b>Redundant Power Supply Present.</b> Active High input indicates presence of redundant power supply. Tie Low if not used.
78	$\overline{\text{RPS\_FAULT}}$	I PU	<b>Redundant Power Supply Fault.</b> Active Low input indicates redundant power supply fault. The state of this input is reflected in the RPS_LED output (refer to LED section). Tie High if not used.
<p>1. I = Input, O = Output, I/O = Input/Output, D = Digital, A = Analog, AI = Analog Input, A I/O = Analog Input/Output, OD = Open Drain, OS = Open Source, PD = Pull Down, PU = Pull Up. NC = No Clamp. Pad does not clamp input in the absence of power.</p> <p>2. Pins are 5V tolerant, unless indicated.</p>			

Table 7: Miscellaneous Signal Descriptions

Pin	Symbol	Type <sup>1, 2</sup>	Description
53	$\overline{\text{RESET}}$	I Schmitt	<b>Reset.</b> This active Low input causes internal circuits, state machines and counters to reset (address tracking registers do not reset). On power-up, devices should not be brought out of reset until the power supply stabilizes to 3.3V. When there are multiple devices, it is recommended all be supplied by a common reset driven by an 'LS14 or similar device.
54	CLK25	I Schmitt	<b>25 MHz system clock.</b> Refer to <a href="#">Table 21 on page 42</a> .
72	$\overline{\text{FPS}}$	I TTL	<b>First Position Select.</b> In multi-chip configurations, this pin identifies one device on each board that drives the HOLDCOL signal to extend non-local collisions to other devices on the board. Set Low for first device on the PCB. Set High for all other devices on the PCB.
25, 33, 51, 52, 55-60, 63-71, 73, 178, 182, 198, 201	N/C	-	<b>No Connects.</b> Leave these pins unconnected.
<p>1. I = Input, O = Output, I/O = Input/Output, D = Digital, A = Analog, AI = Analog Input, A I/O = Analog Input/Output, OD = Open Drain, OS = Open Source, PD = Pull Down, PU = Pull Up. NC = No Clamp. Pad does not clamp input in the absence of power.</p> <p>2. Pins are 5V tolerant, unless indicated.</p>			

## FUNCTIONAL DESCRIPTION

### Introduction

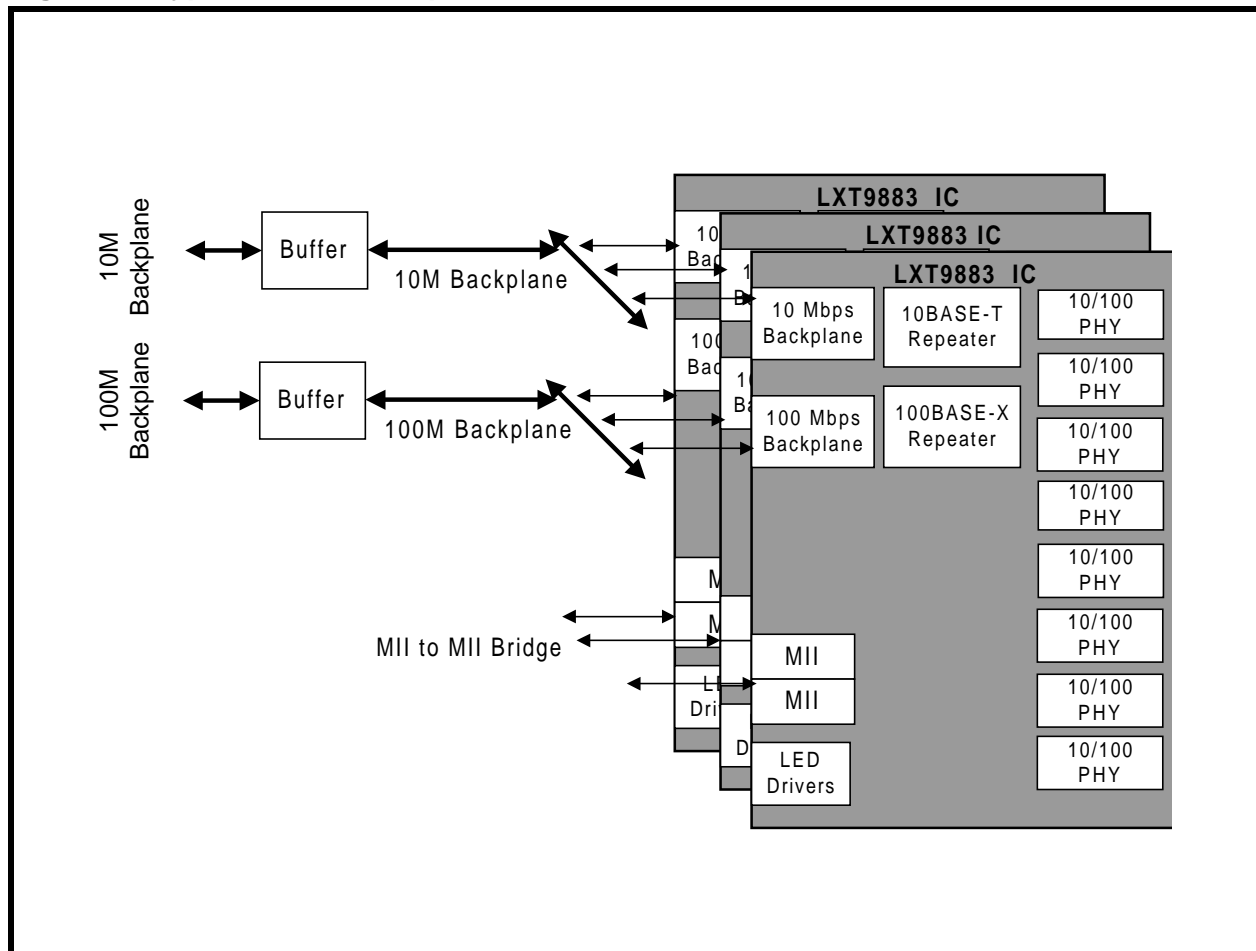
As a fully integrated IEEE 802.3 compliant repeater capable of 10 Mbps and 100 Mbps operation, the LXT98x3 is a versatile device allowing great flexibility in Ethernet design solutions. Figure 2 shows a typical application. Refer to “Application Information” on page 32 for specific circuit implementations.

This multi-port repeater provides six (LXT9863) or eight (LXT9883) 10BASE-T/100BASE-TX ports. In addition, each device also provides two Media Independent Interface (MII) expansion ports that may be connected to 10/100 MACs.

The LXT98x3 provides two repeater state machines and two Inter-Repeater Backplanes (IRB) on a single chip—one for 10 Mbps and one for 100 Mbps operation. The 100 Mbps repeater meets IEEE 802.3 Class II requirements. The auto-negotiation capability of the LXT98x3 allows it to communicate with connected nodes and configure itself accordingly.

The segmented backplane simplifies dual-speed operation, and allows multiple devices to be stacked and function as one logical Class II repeater. Up to 240 ports (192 TP ports and 48 MII ports) can be supported in a single stack.

Figure 2: Typical LXT9883 Repeater Architecture



---

## Port Configuration

The LXT98x3 powers up in auto-negotiation mode for all twisted-pair ports.

### Auto-Negotiation

All TP ports on power-up are configured to establish link via auto-negotiation. The port and link partner establish link conditions by exchanging Fast Link Pulse (FLP) bursts. Each FLP burst contains 16 bits of data advertising the port's capabilities. If the link partner does not support auto-negotiation, the LXT98x3 determines link state by listening for 100 Mbps IDLE symbols or 10 Mbps link pulses. If it detects either of these signals, it configures the port accordingly.

### Link Establishment and Port Connection

Once a port establishes link, the LXT98x3 automatically connects it to the appropriate repeater state machine. If link loss is detected and auto-negotiation is enabled, the port returns to the auto-negotiation state.

## Interface Descriptions

The LXT9883 and LXT9863 provide eight and six network interface ports, respectively. Each port is a twisted-pair interface that directly supports 100BASE-TX (100TX) and 10BASE-T (10T) Ethernet applications and fully complies with IEEE 802.3 standards. A common termination circuit is used.

### Twisted-Pair Interface

The LXT98x3 pinout is optimized for dual-height RJ-45 connectors. The twisted-pair interface for each port consists of two differential signal pairs — one for transmit and one for receive. The transmit signal pair is TPOP/TPON, the receive signal pair is TPIP/TPIN.

The transmitter requires magnetics with 1:1 turns ratio. The center tap of the primary side of the transmit winding must be tied to a quiet VCC for proper operation.

The receiver requires magnetics with a 1:1 turns ratio, and a load of 100  $\Omega$ . When the twisted-pair port is enabled, the receiver actively biases its inputs to approximately 2.8V. A 4 k $\Omega$  load is always present across the TPIP/TPIN pair.

When used in 100TX applications, the LXT98x3 sends and receives a continuous, scrambled 125 Mbaud MLT-3 waveform on this interface. In the absence of data, IDLE symbols are sent and received in order to maintain the link.

When used in 10T applications, the LXT98x3 sends and receives a non-continuous, 10 Mbaud Manchester-encoded waveform. To maintain link during idle periods, the LXT98x3 sends link pulses every 16 ms, and expects to receive them every 10 to 20 ms. Each 10T port automatically detects and sends link pulses, and disables its transmitter if link pulses are not detected. Each 10BASE-T port can detect and automatically correct for polarity reversal on the TPIP/N inputs. The 10BASE-T interface provides integrated filters using Level One's patented filter technology. These filters facilitate low-cost stack designs to meet EMI requirements.

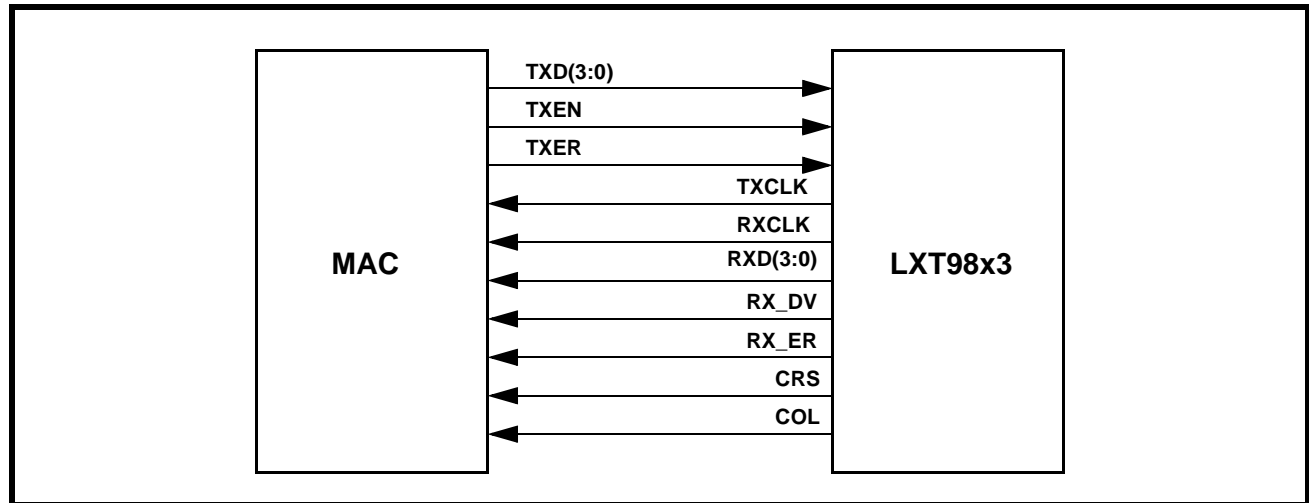


## Media Independent Interface

The LXT98x3 has two identical MII interfaces. The MII has been designed to allow expansion to a Media Access Controller (MAC) as shown in Figure 3. This interface is not MDIO/MDC capable. These MII ports can be set via hardware tie ups/downs to be either 10 or 100 Mbps. These

ports are not the full MII drive strength and are intended only for point-to-point links.

**Figure 3: MII Interface**



## Repeater Operation

The LXT98x3 contains two internal repeater state machines — one operating at 10 Mbps and the other at 100 Mbps. The LXT98x3 automatically switches each port to the correct repeater, once the operational state of that port has been determined. Each repeater connects all ports configured to the same speed (including the MII), and the corresponding Inter-Repeater Backplane. Both repeaters perform the standard jabber and partition functions.

### 100 Mbps Repeater Operation

The LXT98x3 contains a complete 100 Mbps Repeater State Machine (100RSM) that is fully IEEE 802.3 Class II compliant. Any port configured for 100 Mbps operation is automatically connected to the 100 Mbps Repeater. This includes any of the eight media and two MII ports configured for 100 Mbps operation.

The 100 Mbps RSM has its own Inter-Repeater Backplane (100IRB). Multiple LXT98x3s can be cascaded on the 100IRB and operate as one repeater segment. Data from any port is forwarded to all other ports in the cascade. The 100IRB is a 5-bit symbol-mode interface. It is designed to be stackable.

The LXT98x3 performs the following 100 Mbps repeater functions:

- Signal amplification, wave-shape restoration, and data-frame forwarding.
- SOP, SOJ, EOP, EOJ delay < 46BT; class II compliant.
- Collision Enforcement. During a 100 Mbps collision, the LXT98x3 drives a 0101 jam signal (encoded as Data 5 on TX links) to all ports until the collision ends. There is no minimum enforcement time.
- Partition. The LXT98x3 partitions any port that participates in excess of 60 consecutive collisions or one long collision approximately 575.2  $\mu$ s long. Once partitioned, the LXT98x3 monitors and transmits to the port, but does not repeat data received from the port until it un-partitions.
- Un-partition. The un-partition algorithm, which complies with IEEE specification 802.3aa, un-partitions a port on *either* transmit or receive of at least 450-560 bits without collision.
- Isolate. The LXT98x3 isolates any port receiving more than two successive false carrier events. A false carrier event is a packet that does not start with a /J/K symbol pair.

- Un-isolate. The LXT98x3 un-isolates a port that remains in the IDLE state for 33000 +/- 25% BT or that receives a valid frame at least 450-500 BT in length.
- Jabber. The LXT98x3 ignores any receiver remaining active for more than 57,500 bit times. The LXT98x3 exits this state when either one of the following conditions is met:
  - On power-up reset
  - When carrier is no longer detected

### 10 Mbps Repeater Operation

The LXT98x3 contains a complete 10 Mbps Repeater State Machine (10RSM) that is fully IEEE 802.3 compliant. Any port configured for 10 Mbps operation is automatically connected to the 10 Mbps Repeater. This includes any of the media and MII ports configured for 10 Mbps operation.

The 10RSM has its own Inter-Repeater Backplane (10IRB). Multiple LXT98x3s can be cascaded on the 10IRB and operate as one repeater segment. Data from any port is forwarded to all other ports in the cascade.

The LXT98x3 performs the following 10 Mbps repeater functions:

- Signal amplification, wave-shape restoration, and data-frame forwarding.
- Preamble regeneration. All outgoing packets have a minimum 56-bit preamble and 8-bit SFD.
- SOP, SOJ, EOP, EOJ delays meet IEEE 802.3 section 9.5.5 and 9.5.6 requirements.
- Collision Enforcement. During a 10 Mbps collision, the LXT98x3 drives a jam signal (“1010”) to all ports for a minimum of 96 bit times until the collision ends.
- Partition. The LXT98x3 partitions any port in excess of 31 consecutive collisions. Once partitioned, the LXT98x3 continues monitoring and transmitting to the port, but does not repeat data received from the port until it properly un-partitions. (Also partitions for excessive collision length.)
- Un-partition. The algorithm, which complies with the IEEE 802.3 specification, un-partitions a port when data can be either received or transmitted from the port for 450-560 bit times without a collision on that port.
- Jabber. The LXT98x3 asserts a minimum-IFG idle period when a port transmits for longer than 40,000 to 75,000 bit times.

## Requirements

### Power

The LXT98x3 has four types of +3.3V power supply input pins: two digital (VCC, GND) and two analog (VCCR, VCCT). These inputs may be supplied from a single source. Ferrite beads should be used to separate the analog and digital planes. These supplies should be clean.

Each supply input should be decoupled to ground. Refer to [Table 6 on page 12](#) for power and ground pin assignments, and to the “[General Design Guidelines](#)” on [page 32](#).

### Clock

A stable, external 25 MHz system clock source (TTL) is required. This is connected to the CLK25 pin (see [Table 18 on page 35](#)).

### Bias Resistor

The RBIAS input requires a 22.1 k $\Omega$ , 1% resistor connected to ground.

### Reset

At power-up, the reset input must be held Low until VCC reaches at least TBD V. A buffer should be used to drive reset if there are multiple LXT98x3 devices. The clock must be active. IRB Bus Pull-ups

Even when the LXT98x3 is used in a stand-alone configuration, pull-up resistors are required on the IRB signals. See [Figures 15 and 16 on page 41](#).

#### 100 Mbps IRB

IR100CFS

IR100CFSBP

IR100DV

IR100CLK

#### 10Mbps IRB

IR10DAT

IR10ENA

IR10COL

IR10CFS

IR10COLBP

IR10CFSBP

## LED Operation

The LXT98x3 drives the most commonly used LEDs directly (see “[Direct Drive LEDs](#)” on page 23). The less frequently used LEDs are optionally driven via a serial bus to inexpensive Serial-to-Parallel devices (see “[Serial LEDs](#)” on this page).

### LEDs at Start-up

For approximately 2 seconds after the LXT98x3 is reset, all LEDs are driven to the ON state. This start-up routine is an LED check.

## LED Event Stretching

Short lived LED status events are stretched so they may be observed by the human eye. Refer to the LED1, 2, 3 Modes section for stretching specifics.

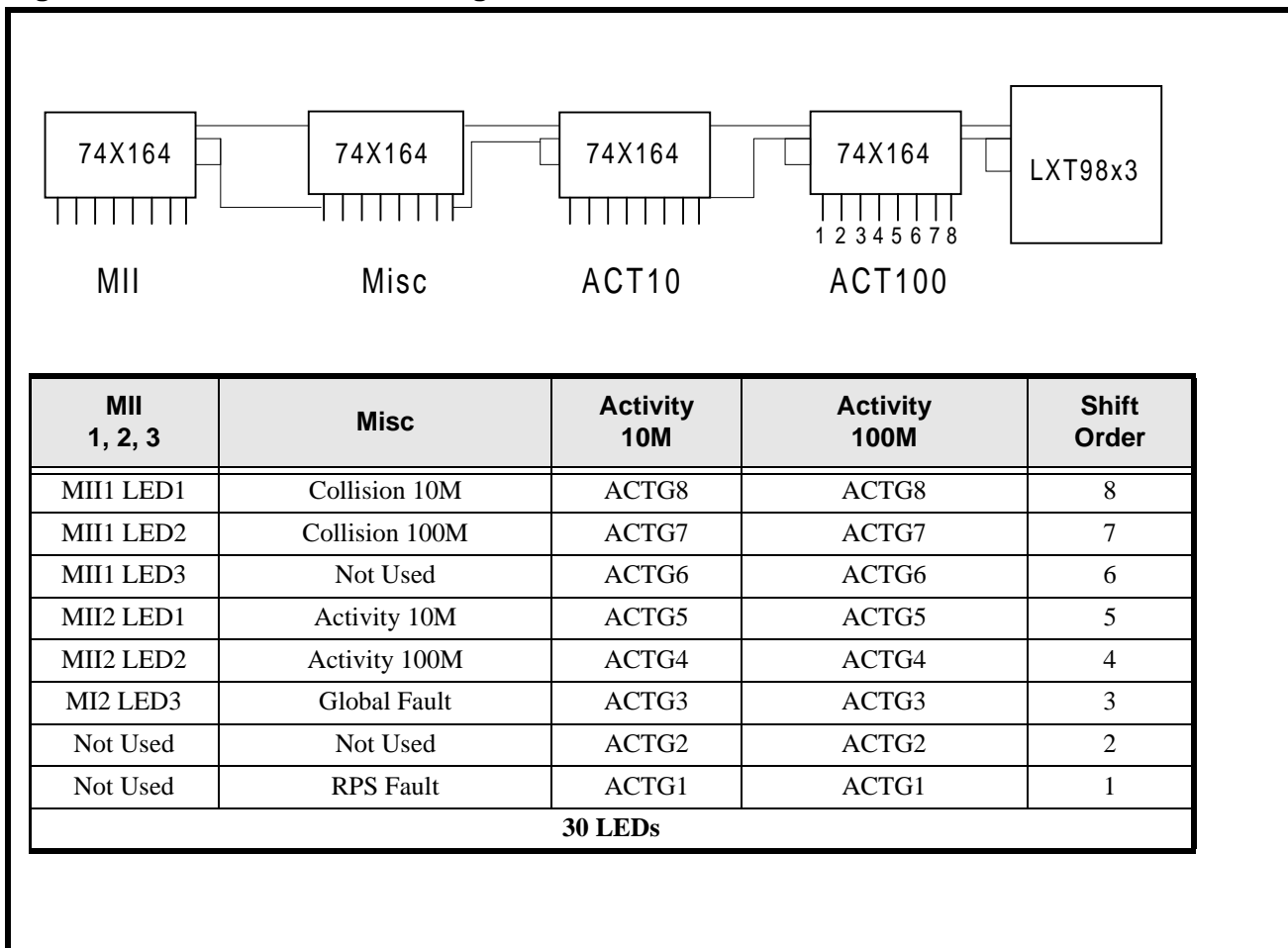
## Serial LED Interface

The LXT98x3 provides a serial interface to drive additional LEDs via external 8-bit Serial-to-Parallel converters. A maximum of 30 LEDs can be driven, using four S/P devices. Collision10/100, Activity10/100 status indications are output on multiplexed configuration pins and are duplicated on the Serial Port (see “[LED Pins Multiplexed with Configuration Inputs](#)” on page 37).

## Serial Shifting

Figure 4 shows the Serial LED shift loading.

Figure 4: Serial LED Shift Loading

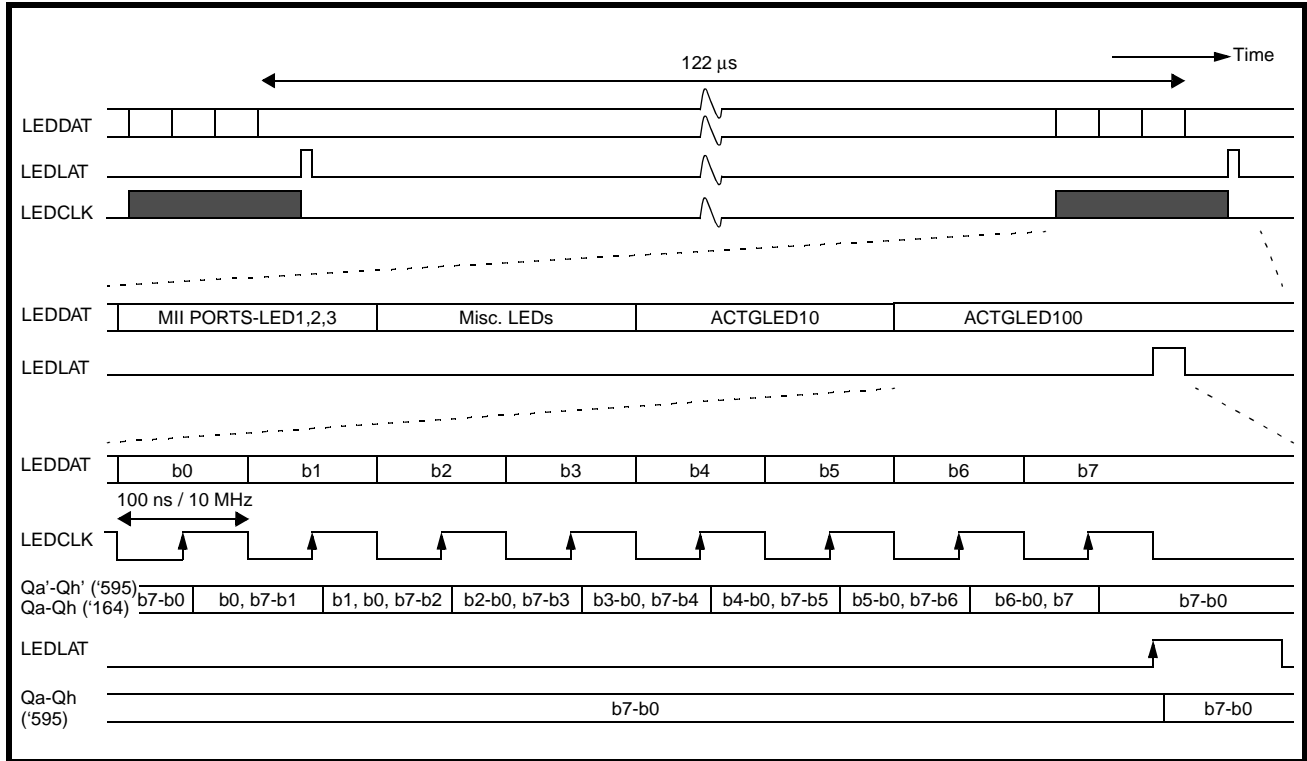


### Serial LED Signals

The LED serial interface bus consists of three LXT98x3 outputs: clock (LEDCLK), parallel load clock (LEDLAT), and output data (LEDDAT). Refer

to Table 5 on page 11 for signal descriptions and to Figure 13 on page 38 for an illustration of the LED serial interface circuit. Refer to Figures 5 and Table 8 for details on the LED serial bit stream.

**Figure 5: Serial LED Port Signaling**



**Table 8: Serial LED Port Bit Stream**

Bit	MII Ports-LED1, 2, 3	Misc.	ACTGLED10	ACTGLED100
7	MII Port 1 - LED1	Collision - 10M <sup>1</sup>	ACTG8	ACTG8
6	MII Port 1 - LED2	Collision - 100M <sup>1</sup>	ACTG7	ACTG7
5	MII Port 1 - LED3	Not Used	ACTG6	ACTG6
4	MII Port 2 - LED1	Activity - 10M <sup>1</sup>	ACTG5	ACTG5
3	MII Port 2 - LED2	Activity - 100M <sup>1</sup>	ACTG4	ACTG4
2	MII Port 2 - LED3	Global Fault	ACTG3	ACTG3
1	Not Used	Not Used	ACTG2	ACTG2
0	Not Used	RPS Fault	ACTG1	ACTG1

1. These LEDs are multiplexed with Configuration Inputs.

## Activity Graph LEDs

The ACTGLED10 and ACTGLED100 LEDs are for activity bar graphing. The activity information is integrated and updated over a period of 328.125 ms, which has the effect of smoothing out the activity. LEDs are provided for both the 10 and 100 Mbps segments.

There are two display modes for the activity bar graphs, Base-2 and Base-10. The modes are selected via the LEDABGSEL pin. Refer to [Table 9](#) for details. Each step LED on the bar graph is lit when the percent activity value associated with that step is met or exceeded.

**Table 9: ACTGLED Display Modes**

LED	LEDABGSEL = 0 (Base-10)	LEDABGSEL = 1 (Base-2)
ACTG 8	60+% Activity	80+% Activity
ACTG 7	50% Activity	64% Activity
ACTG 6	40% Activity	32% Activity
ACTG 5	30% Activity	16% Activity
ACTG 4	20% Activity	8% Activity
ACTG 3	10% Activity	4% Activity
ACTG 2	5% Activity	2% Activity
ACTG 1	1% Activity	1% Activity

## Direct Drive LEDs

The LXT98x3 provides three direct drive LEDs for each port (PORT $n$ \_LED1:3), excluding the two MII ports. Four additional segment LEDs indicate Collision 10/100 and Activity 10/100.) The per-port LEDs are updated simultaneously to illustrate clear, non-overlapping status.

The following device pins are multifunctional (input = configuration; output = LED driver): COL10\_LED (185), ACT10\_LED (183), ACT100\_LED (184), and, PORT8\_LED2 (175).

The drive level is determined by the particular input configuration function of the respective pin. Collision and Activity indications for both 10M and 100M segments are available in both serial and direct drive.

## LED Modes

The four available LED modes are described in [Tables 11 - 15](#). Hardware pins provide global LED mode control. Refer to [Table 5 on page 11](#) for pin assignments and signal description. [Table 10](#) defines terms used to describe LED operation.

**Table 10: LED Terms**

Term	Definition
Port_Enabled	True if port is enabled.
Link_OK	True if link is enabled and link is detected. Always true for MII port.
Port_Partitioned	True if port has been auto partitioned (10Mb mode). True if port has been auto partitioned or isolated (100Mb mode).
Port_Is_TP	True if port is a twisted-pair port.
RPS_Present	True if redundant power supply is switched in.
RPS_Fault	True if redundant power supply has a fault.
Rcv_Activity	True if twisted-pair port on this device is receiving a packet.

## LED Mode 1

Mode 1 operations are described in [Table 11](#).

**Table 11: LED Mode 1 Indications**

LED	Operating Mode	Hardware Control <sup>1</sup>		
		On	Blink	Off
PORT $n$ LED1	10 Mbps operation	Link_OK, not Port_Partitioned	N/A	Any other state
	100 Mbps operation			
PORT $n$ LED2	10 Mbps operation	Link_OK, Port_Partitioned		
	100 Mbps operation			
PORT $n$ LED3	AUTOBLINK active	100M Link_OK	Not Link_OK (Fast Blink)	10M Link_OK
	AUTOBLINK inactive		N/A	

1. Refer to [Table 11: LED Terms](#), which defines all key terms used in this section.

**Table 11: LED Mode 1 Indications** – continued

LED	Operating Mode		Hardware Control <sup>1</sup>		
			On	Blink	Off
Collision and Activity LEDs	Any		<p>The collision and activity LEDs are on a Per Segment basis. Pulse stretchers are used to extend the on-time for the LEDs. For every on- cycle of the stretched LEDs, an off-cycle, with the same period as the on-cycle, always follows.</p> <p>The collision LEDs turn on for approximately 120 <math>\mu</math>s when the LXT98x3 detects a collision on the segments. During the time that the LED is on, any additional collisions are ignored by the collision LED logic.</p> <p>The activity LEDs turn on for approximately 4 ms when the LXT98x3 detects any activity on the segments. During the time that the LED is on any additional activity is ignored by the activity LED logic.</p>		
Global Fault	Any		Any Port_Partitioned or RPS_Fault and RPS_Present	N/A	Any other state
RPS Fault	Any		RPS_Present, RPS_Fault		
1. Refer to <a href="#">Table 11: LED Terms</a> , which defines all key terms used in this section.					



## LED Mode 2

Mode 2 operations are described in [Table 12](#).

**Table 12: LED Mode 2 Indications**

LED	Operating Mode		Hardware Control <sup>1</sup>		
			On	Blink	Off
PORT <sub>n</sub> LED1	Any		<b>10M:</b> Port_Enabled, Link_OK, not Port_Partitioned <b>100M:</b> Port_Enabled, Link_OK, not Port_Partitioned	<b>10M:</b> Port_Enabled, Link_OK, and Port_Partitioned (slow blink) <b>100M:</b> Port_Enabled, Port_Partitioned (Slow Blink)	Any other state
PORT <sub>n</sub> LED2			Rcv_Activity (20 ms pulse) <sup>2</sup>	N/A	Any other state
PORT <sub>n</sub> LED3	AUTOBLINK active		100M Link_OK	No Link_OK (Fast Blink)	10M Link_OK
	AUTOBLINK inactive			N/A	
Collision and Activity LEDs	Any		<p>The collision and activity LEDs are on a Per Segment basis. Pulse stretchers are used to extend the on-time for the LEDs. For every on-cycle of the stretched LEDs, an off-cycle, with the same period as the on-cycle, always follows.</p> <p>The collision LEDs turn on for approximately 120 μs when the LXT98x3 detects a collision on the segments. During the time that the LED is on, any additional collisions are ignored by the collision LED logic.</p> <p>The activity LEDs turn on for approximately 4 ms when the LXT98x3 detects any activity on the segments. During the time that the LED is on, any additional activity is ignored by the activity LED logic.</p>		
RPS Fault	Any		PRS_Present, no RPS_Fault	PRS_Present, RPS_Fault (Slow Blink)	Not RPS_Present
Global Fault	Any		N/A	Any Port_Partitioned, any Port Isolated or RPS_Fault and RPS_Present (Slow Blink)	Any other state

1. Refer to [Table 10: LED Terms](#), which defines all key terms used in this section.  
 2. Receive activity is stretched to a 20 ms wide pulse. For every on-cycle of the stretched LEDs, an off-cycle, with the same period as the on-cycle, always follows.

### LED Mode 3

Mode 3 operations are described in [Table 13](#).

**Table 13: LED Mode 3 Indications**

LED	Operating Mode	Hardware Control		
		On	Blink	Off
PORT $n$ LED1	10 Mbps operation	Link_OK, not Port_Partitioned	N/A	Any other state
	100 Mbps operation			
PORT $n$ LED2	Any	Rcv_Activity (20 ms pulse) <sup>2</sup>	N/A	Any other state
PORT $n$ LED3	AUTOBLINK active	100M Link_OK	No Link_OK (Fast Blink)	10M Link_OK
	AUTOBLINK inactive	100M mode selected	N/A	10M mode selected
Collision and Activity LEDs	Any	<p>The collision and activity LEDs are on a Per Segment basis. Pulse stretchers are used to extend the on-time for the LEDs. For every on-cycle of the stretched LEDs, an off-cycle, with the same period as the on-cycle, always follows.</p> <p>The collision LEDs turn on for approximately 120 <math>\mu</math>s when the LXT98x3 detects a collision on the segments. During the time that the LED is on, any additional collisions is ignored by the collision LED logic.</p> <p>The activity LEDs turn on for approximately 4 ms when the LXT98x3 detects any activity on the segments. During the time that the LED is on, any additional activity is ignored by the activity LED logic.</p>		
Global Fault	Any	Any Port_Partitioned or RPS_Fault and RPS_Present	N/A	Any other state
RPS Fault	Any	RPS_Present, RPS_Fault		
<p>1. Refer to <a href="#">Table 10</a>: LED Terms, which defines all key terms used in this section.</p> <p>2. Receive activity is stretched to a 20 ms wide pulse. For every on-cycle of the stretched LEDs, an off-cycle, with the same period as the on-cycle, always follows.</p>				

## LED Mode 4

Mode 4 operations are described in [Table 14](#).

**Table 14: LED Mode 4 Indications**

LED	Operating Mode	Hardware Control <sup>1</sup>		
		On	Blink	Off
PORT <sub>n</sub> LED1	10 Mbps operation	Link_OK, not Port_Partitioned	20 ms Blink indicates Rcv_Activity <sup>2</sup>	Any other state
	100 Mbps operation			Any other state
PORT <sub>n</sub> LED2	10 Mbps operation	Link_OK, Port_Partitioned	N/A	Any other state
	100 Mbps operation			
PORT <sub>n</sub> LED3	AUTOBLINK $\bar{K}$ active	100M Link_OK	No Link_OK (Fast Blink))	10M Link_OK
	AUTOBLINK $\bar{K}$ inactive		N/A	
Collision and Activity LEDs	Any	<p>The collision and activity LEDs are on a Per Segment basis. Pulse stretchers are used to extend the on-time for the LEDs. For every on-cycle of the stretched LEDs, an off-cycle, with the same period as the on-cycle, always follows.</p> <p>The collision LEDs turn on for approximately 120 <math>\mu</math>s when the LXT98x3 detects a collision on the segments. During the time that the LED is on, any additional collisions are ignored by the collision LED logic.</p> <p>The activity LEDs turns on for approximately 4 ms when the LXT98x3 detects any activity on the segments. During the time that the LED is on, any additional activity is ignored by the activity LED logic.</p>		
Global Fault	Any	Any port partitioned or RPS_Fault and RPS_Present	N/A	Any other state
RPS Fault	Any			
<p>1. Refer to <a href="#">Table 10: LED Terms</a>, which defines all key terms used in this section.</p> <p>2. Receive activity is stretched to a 20 ms wide pulse. For every on-cycle of the stretched LEDs, an off-cycle, with the same period as the on-cycle, always follows.</p>				

## IRB Operation

The Inter-Repeater Backplane (IRB) allows multiple devices to operate as a single logical repeater, exchanging data and collision status information. Each segment on the LXT98x3 has its own complete, independent IRB. The backplanes use a combination of digital and analog signals as shown in [Figure 7 on page 29](#).

## IRB Signal Types

IRB signals can be characterized by the following connection types (For Stacking and Cascading connections, see [Table 15 on page 30](#)):

- **Local**—connected between devices on the same board
- **Stack**—connected between boards
- **Full**—connected between devices in the same board *and* between boards.

## 10M-Only Operation

### MAC IRB Access

The MACACTIVE pin allows an external MAC or other digital ASIC to interface directly to the 10 Mbps IRB. When the MACACTIVE pin is asserted, the LXT98x3 drives the  $\overline{\text{IR10CFS}}$  and  $\overline{\text{IR10CFSBP}}$  signals on behalf of the external device, allowing it to participate in collision detection functions.

## LXT98x/91x/98xx Compatibility

The LXT98x3 devices feature low-power 3.3V design. The LXT98x and LXT91x devices operate at 5V and are incompatible with the LXT98x3 devices in cascades. The LXT98x3 devices, however, are *backwards stackable* with LXT98x and LXT91x repeaters.

### NOTE

Refer to “Inter-Repeater Backplane Compatibility” on [page 39](#).

Figure 6: 100M IRB Connection

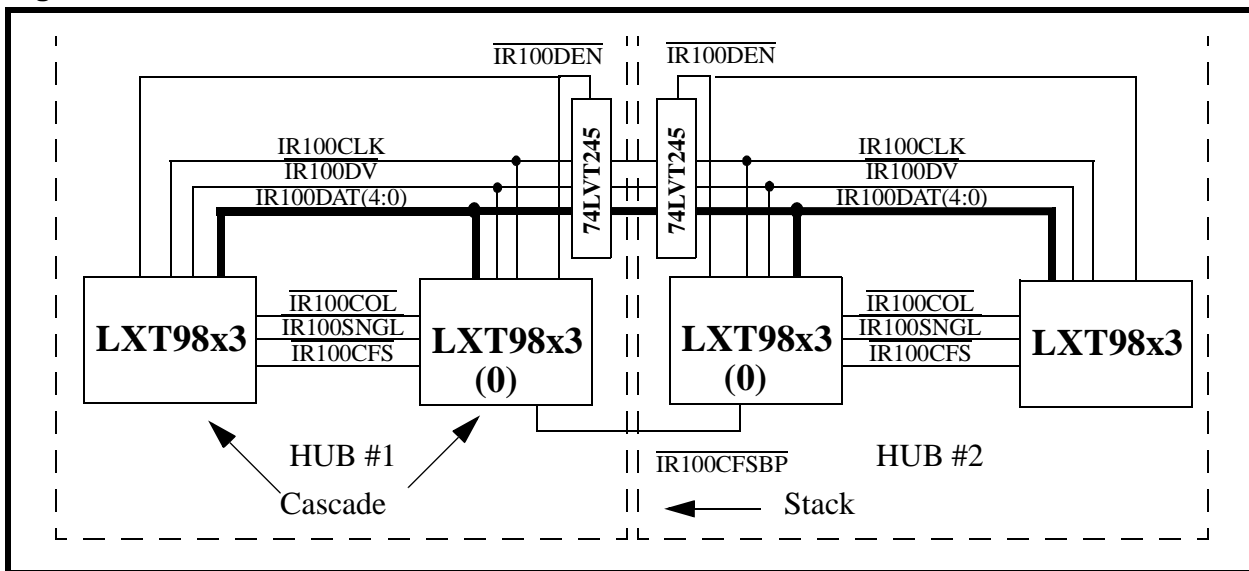


Figure 7: IRB Block Diagram

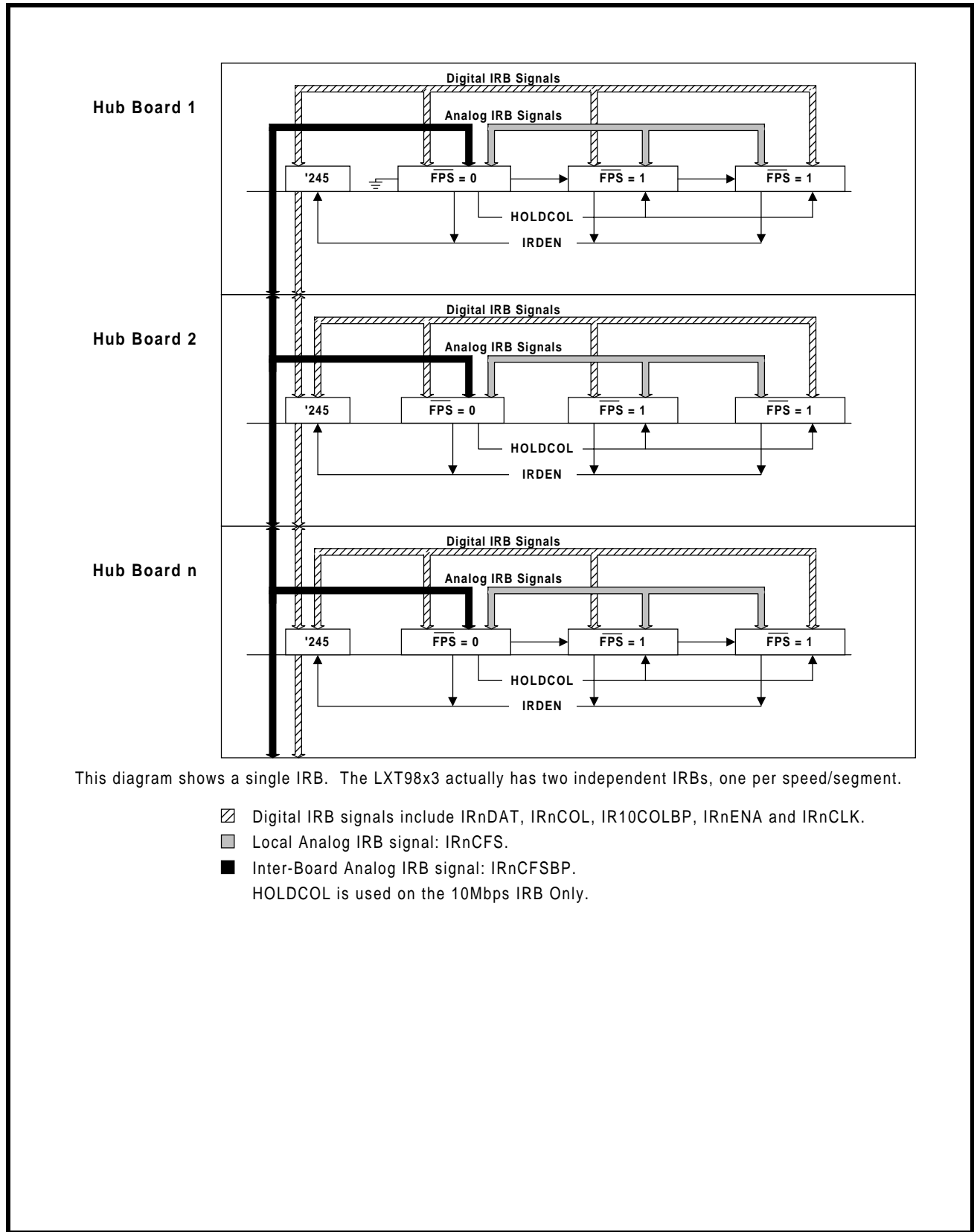


Table 15: Cascading and Stacking Connections

Signal Type	Connections Between Devices (Cascading)	Connections Between Boards (Stacking)
Local	Connect all.	<i>Do not connect.</i>
Stack	For devices with $\overline{\text{FPS}} = 0$ , pull-up at each device and <i>do not interconnect.</i>	Connect devices with $\overline{\text{FPS}} = 0$ between boards. Use one pull-up resistor per stack.
Full	Connect all.	Connect using buffers.

Table 16: IRB Signal Details

Name	Pad Type	Buffer	Pull-up	Connection Type
<b>100 Mbps IRB Signals</b>				
IR100DAT<4:0>	Digital	Yes	No	Full
IR100CLK	Digital	Yes	1K	Full
$\overline{\text{IR100DV}}$	Digital, Open Drain	Yes	300 $\Omega$	Full
$\overline{\text{IR100CFS}}$	Analog	No	215 $\Omega$ , 1%	Local
$\overline{\text{IR100CFSBP}}$	Analog	No	91 $\Omega$ , 1%	Stack
$\overline{\text{IR100COL}}$	Digital	No	No	Local
$\overline{\text{IR100SNGL}}$	Digital	No	No	Local
$\overline{\text{IR100DEN}}$	Digital, Open Drain	N/A <sup>1</sup>	330 $\Omega$	Local
<b>10 Mbps IRB Signals</b>				
IR10DAT	Digital, Open Drain	Yes	330 $\Omega$	Full
IR10CLK	Digital	Yes	No	Full
$\overline{\text{IR10ENA}}$	Digital, Open Drain	Yes	330 $\Omega$	Full
$\overline{\text{IR10CFS}}$	Analog	No	215 $\Omega$ , 1%	Local
$\overline{\text{IR10CFSBP}}$	Analog	No	330 $\Omega$ , 1%	Stack
$\overline{\text{IR10COL}}$	Digital	No	330 $\Omega$ , 1%	Local
$\overline{\text{IR10COLBP}}$	Digital	No	330 $\Omega$ , 1%	Stack
$\overline{\text{IR10DEN}}$	Digital, Open Drain	N/A <sup>1</sup>	330 $\Omega$	Local
1. Driver Enable signals are provided to control an external bidirectional transceiver.				

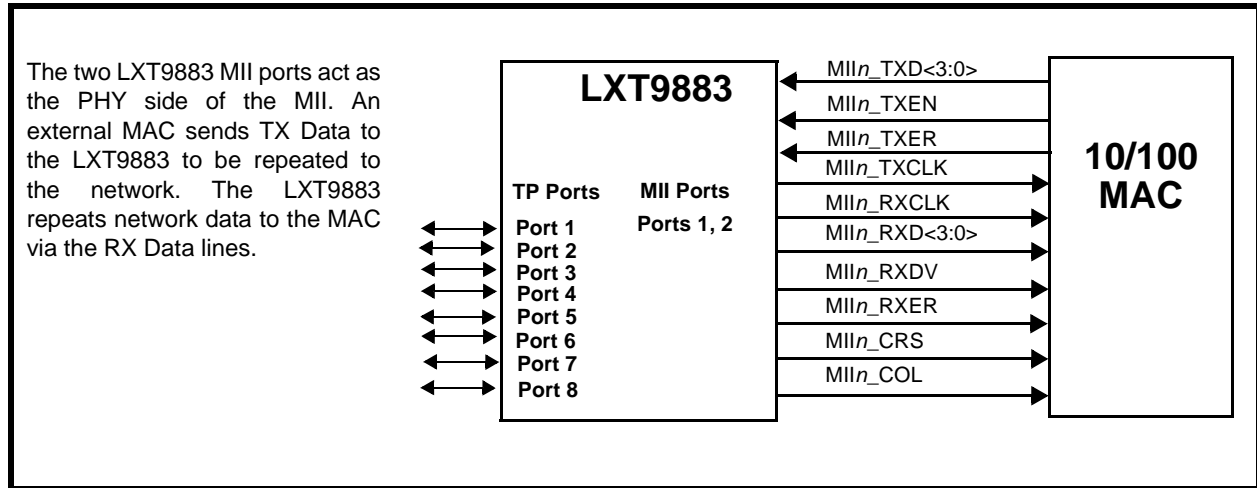
## MII Port Operation

The LXT98x3 MII ports allow direct connection with a MAC. The MII ports can operate at either 10 or 100 Mbps. Speed control is provided via  $MII_n\_SPD$ . For 100M operation, set  $MII_n\_SPD = 1$ . For 10M operation, set  $MII_n\_SPD = 0$ .

## Preamble Handling

When operating at 100 Mbps, the LXT98x3 passes the full 56 bits of preamble through before sending the SFD. When operating at 10 Mbps, the LXT98x3 sends data across the MII starting with the 8-bit SFD (no preamble bits).

**Figure 8: LXT9883 MII Operation**



---

## APPLICATION INFORMATION

---

### General Design Guidelines

Following generally accepted design practices is essential to minimize noise levels on power and ground planes. Up to 50 mV of noise is considered acceptable. 50 to 80 mV of noise is considered marginal. High-frequency switching noise can be reduced, and its effects can be eliminated, by following these simple guidelines throughout the design:

- Fill in unused areas of the signal planes with solid copper. Attach them with vias to a VCC or ground plane that is not located adjacent to the signal layer.
- Use ample bulk and decoupling capacitors throughout the design (a .01  $\mu$ F value is recommended for decoupling caps).
- Provide ample power and ground planes.
- Provide termination on all high-speed switching signals and clock lines.
- Provide impedance matching on long traces to prevent reflections.
- Route high-speed signals next to a continuous, unbroken ground plane.
- Filter and shield DC-DC converters, oscillators, etc.
- Do not route any digital signals between the LXT98x3 and the RJ-45 connectors at the edge of the board.
- Do not extend any circuit power and ground plane past the center of the magnetics or to the edge of the board. Use this area for chassis ground, or leave it void.

### Power and Ground

#### Supply Filtering

Power supply ripple and digital switching noise on the VCC plane causes EMI and degrades line performance. Predicting a design's performance is difficult, although certain factors greatly increase the risks:

- Poorly-regulated or over-burdened power supplies.
- Wide data busses (>32-bits) running at a high clock rate.
- DC-to-DC converters.

Many of these issues can be improved by following good general design guidelines. In addition, Level One recommends filtering between the power supply and the analog VCC pins of the LXT98x3. Filtering has two benefits. First, it keeps digital switching noise out of the analog circuitry inside the LXT98x3, which helps line performance. Second, if the VCC planes are laid out correctly, it keeps digital switching noise away from external connectors, reducing EMI.

The VCC plane should be divided into two sections. The digital section supplies power to the digital VCC pins and to the external components. The analog section supplies power to VCCR and VCCT pins of the LXT98x3. The break between the two planes should run under the device. In designs with more than one LXT98x3, use a single continuous analog VCC plane to supply them all.

The digital and analog VCC planes should be joined at one or more points by ferrite beads. The beads should produce at least a 100 $\Omega$  impedance at 100 MHz. The beads should be placed so current flows evenly. The maximum current rating of the beads should be at least 150% of the current that is actually expected to flow through them. Each LXT98x3 draws a maximum of TBD mA from the analog supply so beads rated at TBD mA should be used. A bulk cap (2.2 -10  $\mu$ F) should be placed on each side of each ferrite bead to ground to stop switching noise from traveling through the ferrite.

In addition, a high-frequency bypass cap (.01 $\mu$ f) should be placed near each analog VCC pin to ground.



## Ground Noise

The best approach to minimize ground noise is strict use of good general design guidelines and by filtering the VCC plane.

## Power and Ground Plane Layout Considerations

The power and ground planes should be laid out carefully. The following guidelines are recommended:

- Follow the guidelines in the *Application Note 113 (LXT98x3 Design and Layout Guide)* for locating the split between the digital and analog VCC planes.
- Keep the digital VCC plane away from the TPOP/N and TPIP/N signals, magnetics, and RJ-45 connectors.
- Place the layers so the TPOP/N and TPIP/N signals are routed near or next to the ground plane. For EMI, it is more important to shield TPOP/N than TPIP/N.

## Chassis Ground

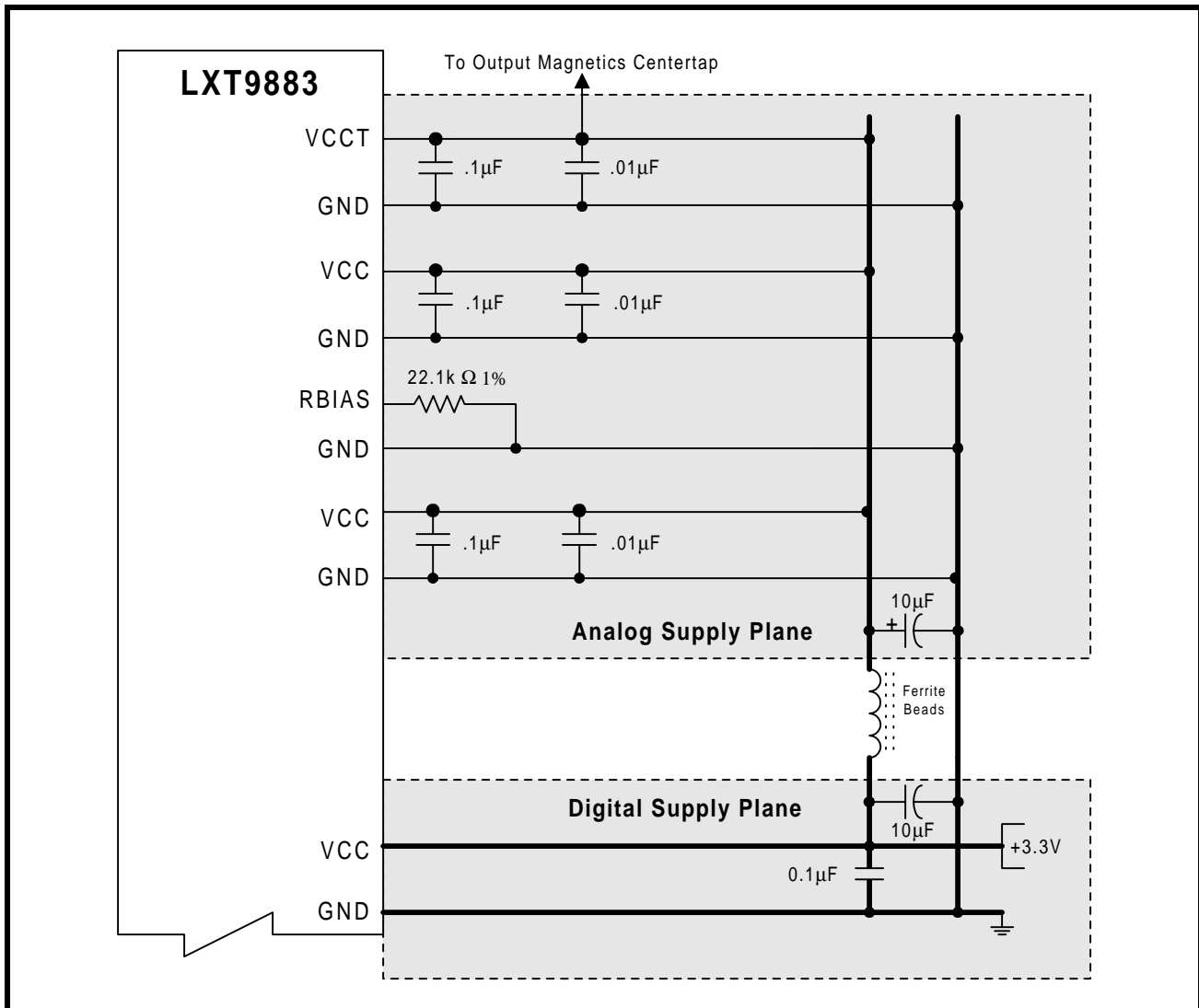
For ESD protection, create a separate chassis ground. For isolation, encircle the board and place a “moat” around the signal ground plane to separate signal ground from chassis ground. Chassis ground should extend from the RJ-45 connectors to the magnetics, and can be used to terminate unused signal pairs (‘Bob Smith’ termination). In single-point grounding applications, provide a single connection between chassis and circuit grounds with a 2kV isolation capacitor. In multi-point grounding schemes (chassis and circuit grounds joined at multiple points), provide 2kV isolation to the Bob Smith termination.

## The RBIAS Pin

The LXT98x3 requires a 22.1 k $\Omega$ , 1% resistor directly connected between the RBIAS pin and ground. Place the RBIAS resistor as close to the RBIAS pin as possible. Run an etch directly from the pin to the

resistor, sink the other side of the resistor, and surround the RBIAS trace with a filtered ground. *Do not run high-speed signals next to RBIAS.*

**Figure 9: Power and Ground Connections**



## MII Terminations

The LXT98x3 MIIs have high output impedance (250-350 $\Omega$ ). To minimize reflections, serial termination resistors are recommended on all MII signals, especially with designs with long traces (>3 inches). Place the resistor as close to the device as possible. Use a software trace termination package to select an optimal resistance value for the specific trace. Proper value = nominal trace

impedance minus 13 $\Omega$ . If a software package cannot be used and nominal trace impedance is not known, use 55 $\Omega$ .

## Twisted-Pair Interface

The LXT98x3 transmitter uses standard 1:1 magnetics for both receive and transmit. Nonetheless, system designers should take precautions to minimize parasitic shunt capacitance and meet return loss specifications. These steps include:

- Place magnetics as close as possible to the LXT98x3.
- Keep transmit pair traces short.
- Do not route transmit pair adjacent to a ground plane. Eliminate planes under the transmit traces completely. Otherwise, keep planes 3-4 layers away.
- Improve EMI performance by filtering the output center tap supply. A single ferrite bead may be used in the center tap supply to all ports. All ports draw a combined total of  $\geq$  TBD mA, so the bead should be rated at  $\geq$  TBD mA.
- Place the 270 pF 5% capacitors at TPIP and TPIN to improve the signal-to-noise immunity at the receiver.

In addition, follow all the standard guidelines for a twisted-pair interface:

- Route the signal pairs differentially, close together. Allow nothing to come between them.

- Keep distances as short as possible; both traces should have the same length.
- Avoid vias and layer changes.
- Keep the transmit and receive pairs apart to avoid cross-talk.
- To provide maximum isolation, place entire receive termination network on one side and transmit on the other side of the PCB.
- Bypass common-mode noise to ground on the in-board side of the magnetics using 0.01  $\mu$ F capacitors.
- Keep termination circuits grouped closely together and on the same side of the board.
- Always put termination circuits close to the source end of any circuit.

## Magnetics Information

The LXT98x3 requires a 1:1 ratio for the receive transformers and a 1:1 ratio for the transmit transformers. The transformer isolation voltage should be rated at 2 kV to protect the circuitry from static voltages across the connectors and cables. Refer to [Table 17](#) for magnetics specifications.

**Table 17: LXT98x3 Magnetics Specifications**

Parameter	Min	Nom	Max	Units	Test Condition
Rx turns ratio	–	1 : 1	–	–	
Tx turns ratio	–	1 : 1	–	–	
Insertion loss	0.0	–	1.1	dB	80 MHz
Primary inductance	350	–	–	$\mu$ H	
Transformer isolation	–	2	–	kV	
Differential to common mode rejection	-40	–	–	dB	.1 to 60 MHz
	-35	–	–	dB	60 to 100 MHz
Return Loss - standard	-16	–	–	dB	30 MHz
	-10	–	–	dB	80 MHz

## Clock

A stable, external 25 MHz system clock source (TTL) is required. This is connected to the CLK25 pin. (see [Table 18](#)).

**Table 18: Oscillator Manufacturers**

Manufacturer	Part Number	Frequency
CTS	MXO45 / 45LV	25 MHz
Epson America	SG-636 Series	25 MHz
TXC Corporation	505EC	25 MHz
USI Corporation	UC1-2BLC	25 MHz

Figure 10: Typical Twisted-Pair Port Interface and Power Supply Filtering

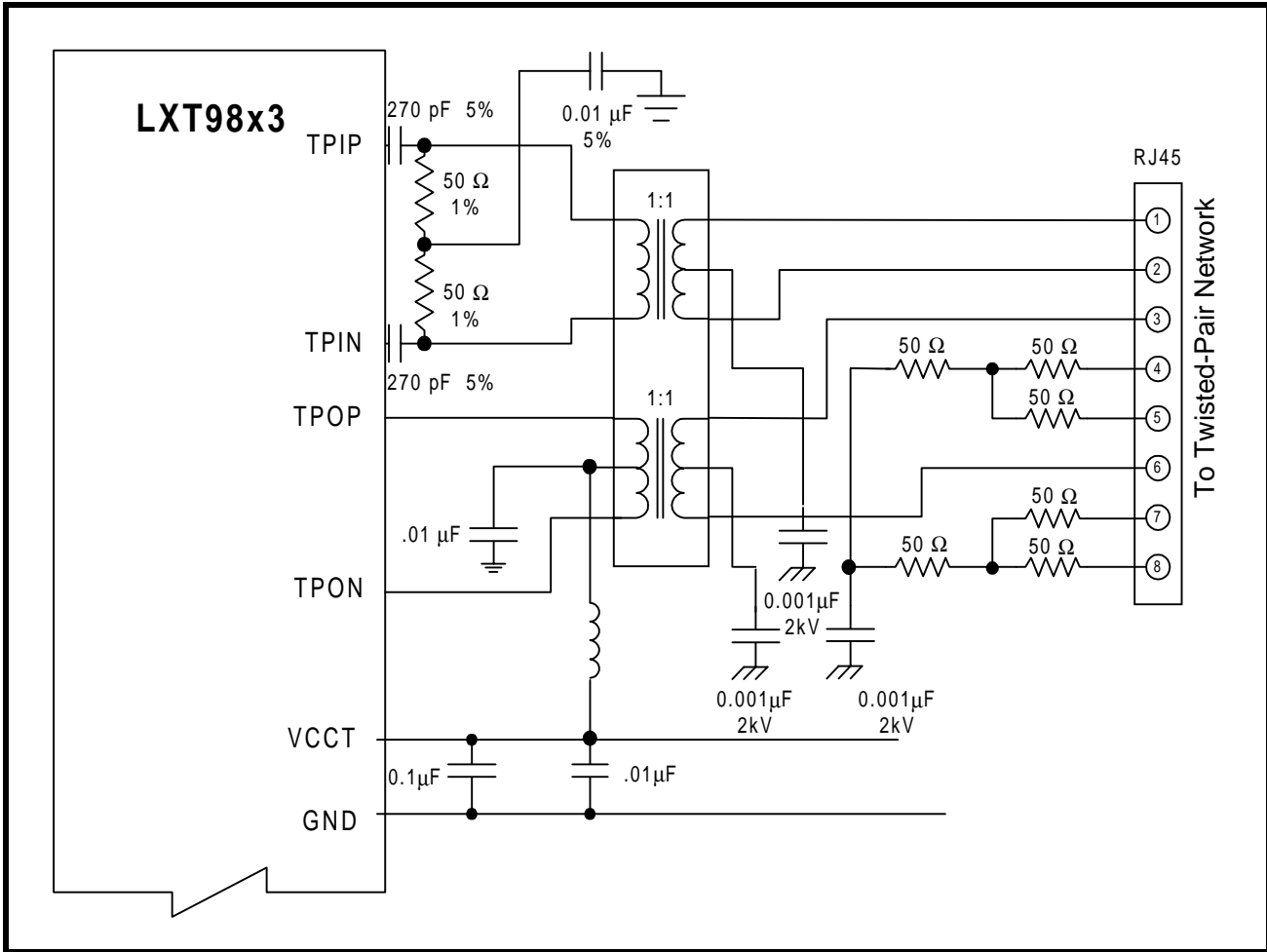
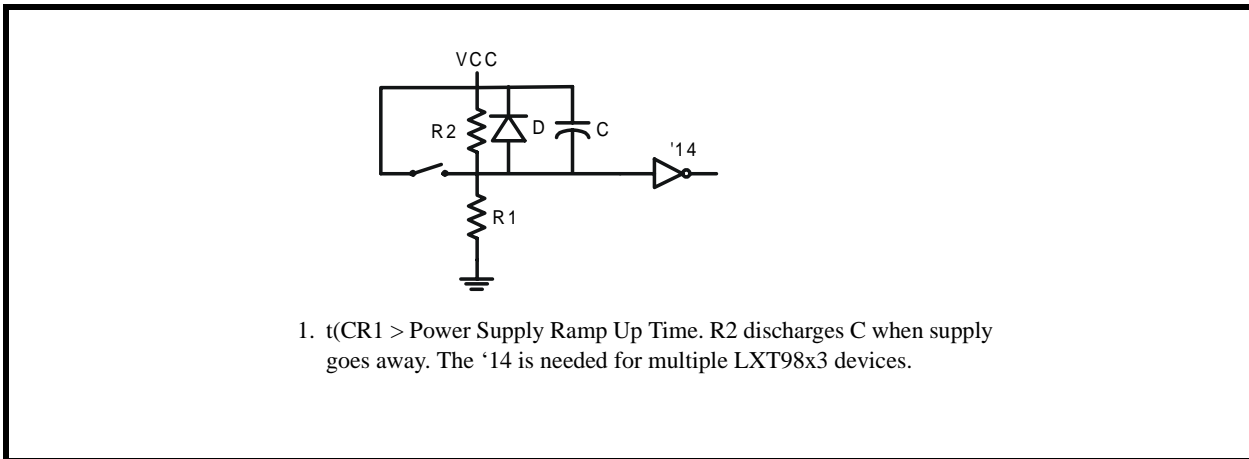


Figure 11: Typical Reset Circuit



## LED Circuits

### Direct Drive LEDs

Each Direct Drive LED has a corresponding open-drain pin. The LEDs are connected, via a current limiting resistor, to a positive voltage rail. The LEDs are turned on when the output pin drives Low. The open-drain LED pins are 5V tolerant, allowing use of either a 3.3V or 5V rail. A 5V rail eases LED component selection by allowing more common, high forward voltage LEDs to be used. Refer to [Figure 12](#) for a circuit illustration.

### LED Pins Multiplexed with Configuration Inputs

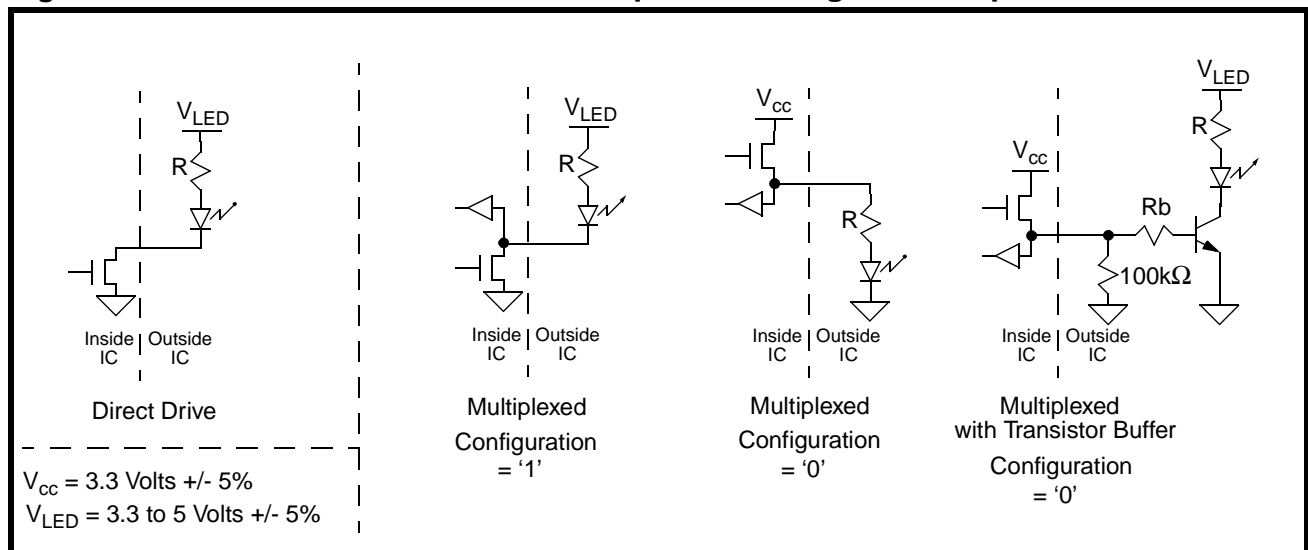
Some static configuration inputs are multiplexed with LED pins to reduce the LXT98x3 pin count. These LED pins are configured by current sinking (open-drain output) and sourcing (open-source output). If the LED pin sinks the LED current, the configuration value is '1'. If LED pin sources the current, the configuration value is a '0'. The LXT98x3 detects the

configuration value following reset and then selects the appropriate output drive circuit (open drain or source). If the LED function of a multiplexed configuration pin is not used, tie the pin to Ground or Vcc via a 100–500 kΩ resistor to set the configuration value. Multiple LED configuration pins can be tied off with a single resistor to set them all to the same value. Refer to [Figure 12](#) for a circuit illustration.

For configuration values of '1', a 3.3V or a 5V rail can be used to drive the LEDs (to ease LED selection as with Direct Drive LEDs).

For configuration values of '0', external buffering is used when 5V LED driving is desired. (This buffering could be as simple as a single transistor.) As an alternative, use the copies of the multiplexed LED data found on the LED serial interface. 5V LED driving is achieved. Also, if a 5V tolerant serial-to-parallel device is used for the LED serial interface, 5V LED driving is achieved (see [“Serial LEDs”](#) on [page 38](#)).

**Figure 12: LED Circuits - Direct Drive & Multiplexed Configuration Inputs**



## Serial LEDs

The LXT98x3 provides a serial interface to support additional LED options. Standard shift registers, either 74X595s (8-bit Serial-to-Parallel with Output Registers) or 74X164s (8-bit S/P without registers) can be used to drive these additional LEDs. Collision10/100 and Activity10/100 status indications are provided on multiplexed configuration pins and duplicated on the serial port.

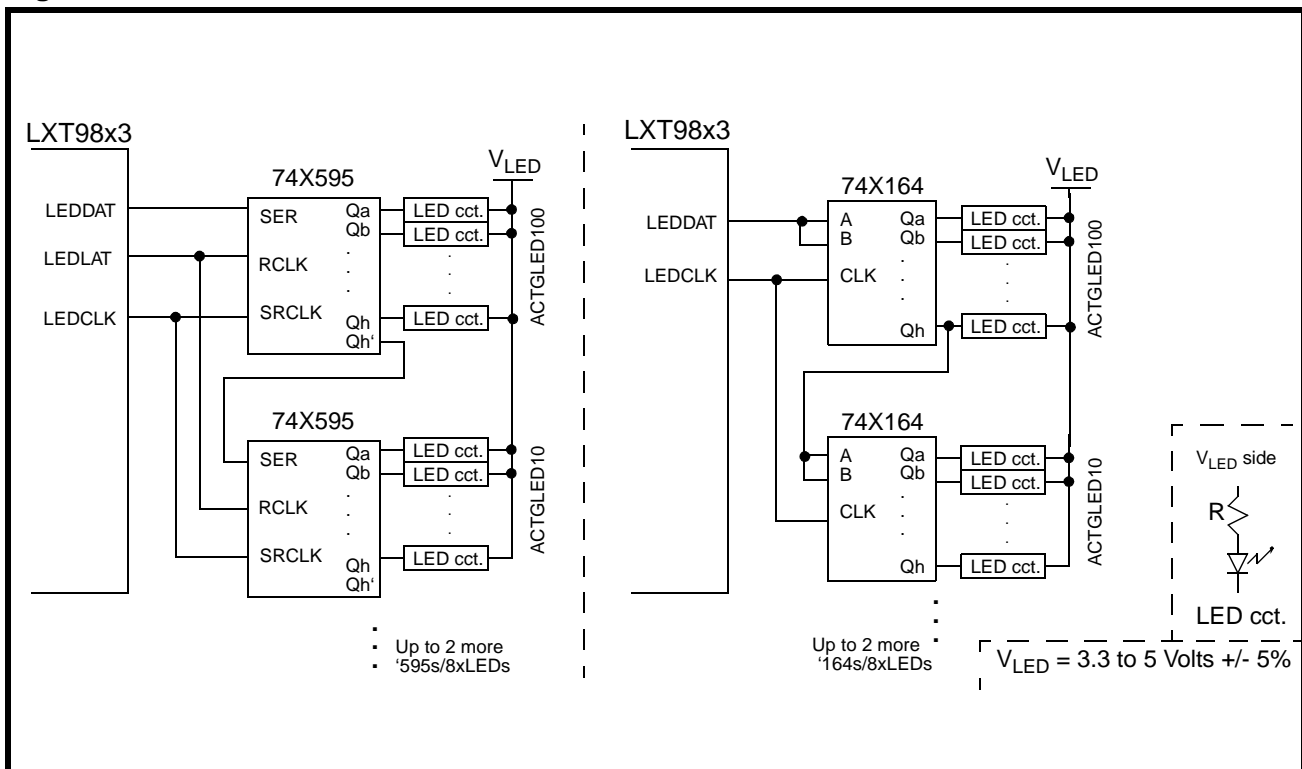
The LED serial interface consists of three outputs: clock (LEDCLK), parallel latch clock (LEDLAT), and output data (LEDDAT). The parallel latch clock is used only with the 74X595 implementation. Refer to [Figure 13](#) for an illustration of the LED serial interface circuit.

Potentially, 30 LEDs can be driven by the LED serial interface via 4 S/P devices. The S/P serial output is connected to the serial input of the first serial input device. To expand the chain, connect the last serial output to serial input of next serial interface device.

Serial LED data is output in the anticipated priority order, from least likely to most likely to be used:

- Unused '595/'164 parallel outputs
- MII Ports - LED1, 2, 3
- Miscellaneous LEDs (Repeat of Collision10/100, Repeat of Activity10/100, Global Fault, RPS Fault)
- ACTGLED10
- ACTGLED100

**Figure 13: Serial LED Circuit**



## Inter-Repeater Backplane Compatibility

The Inter-repeater Backplane (IRB) comprises two parts:

- Local—the backplane between cascaded devices on the same board.
- Stack—the backplane between multiple boards.

Each of these backplanes consists of both analog and digital signals.

### Local Backplane—3.3V Only

The LXT98x3 local backplane operates at 3.3V only. LXT98x and LXT91x devices operate at 5V. LXT98x3 devices are, therefore, not cascadable with LXT98x and LXT91x devices.

#### NOTE

Do not mix LXT98x3 with either LXT98x or LXT91x devices on the local backplanes.

### Stack Backplane—3.3V or 5V

The LXT98x3 stack backplanes can be configured to be either 3.3V or 5V. COMP\_SEL (Pin 39), a special input pin, selects between the two voltage modes, depending on whether 3.3V or 5V is applied.

**3.3V-Only Stacks.** Apply 3.3V to COMP\_SEL, IR100CFSBP, IR10CFSBP, and IR10COLBP for LXT98x3 backplane operation

**For 5V Backwards Stackability.** Apply 5V to COMP\_SEL, IR100CFSBP, IR10CFSBP, and IR10COLBP for LXT98x and LXT91x backplane operation.

With either mode (3.3V or 5V), COMP\_SEL draws less than 3 mA.

#### NOTE

1. The external pull-up resistor values remain the same, regardless of 3.3V or 5V backplane operation.
2. The recommended digital signal external buffer has been changed to 74LVT245 for the LXT98x3.

### 3.3V and 5.0V Stacking Boards Cannot Be Mixed

#### 3.3V Operation

Boards designed for 3.3V backplane operation should only be stacked with other 3.3V boards. Existing LXT98x or LXT91x based designs cannot operate in 3.3V.

**Incompatible Stacking Configurations.** The following stacking configurations are incompatible:

- A LXT98x3-based board configured for 3.3V backplane operation and LXT98x or LXT91x based boards (5V only).
- A LXT98x3-based board configured for 3.3V backplane operation and a LXT98x3-based board configured for 5V backplane operation.

#### NOTE

Stacking boards designed for 3.3V backplane operation with boards designed for 5V backplane operation causes network errors.

#### 5V Operation

Boards designed for 5V backplane operation should only be stacked with other 5V boards:

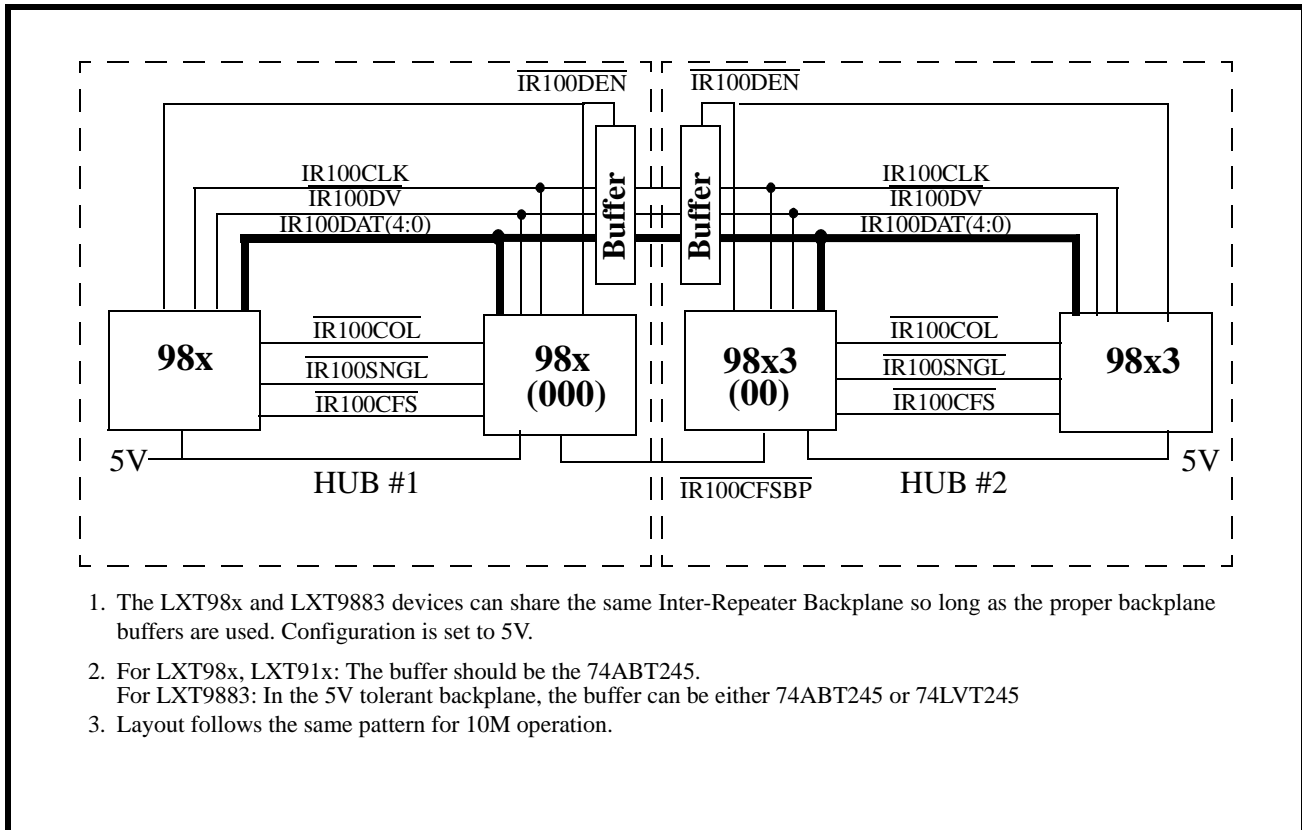
- LXT98x or LXT91x-based designs.
- LXT98x3 designs configured for 5V backplane operation.

The configuration input must be connected to 5V for compatibility with LXT98x or LXT91x-based designs. The 5V can be supplied from the stacking cable, or a 5V source must exist within the board itself.

#### NOTE

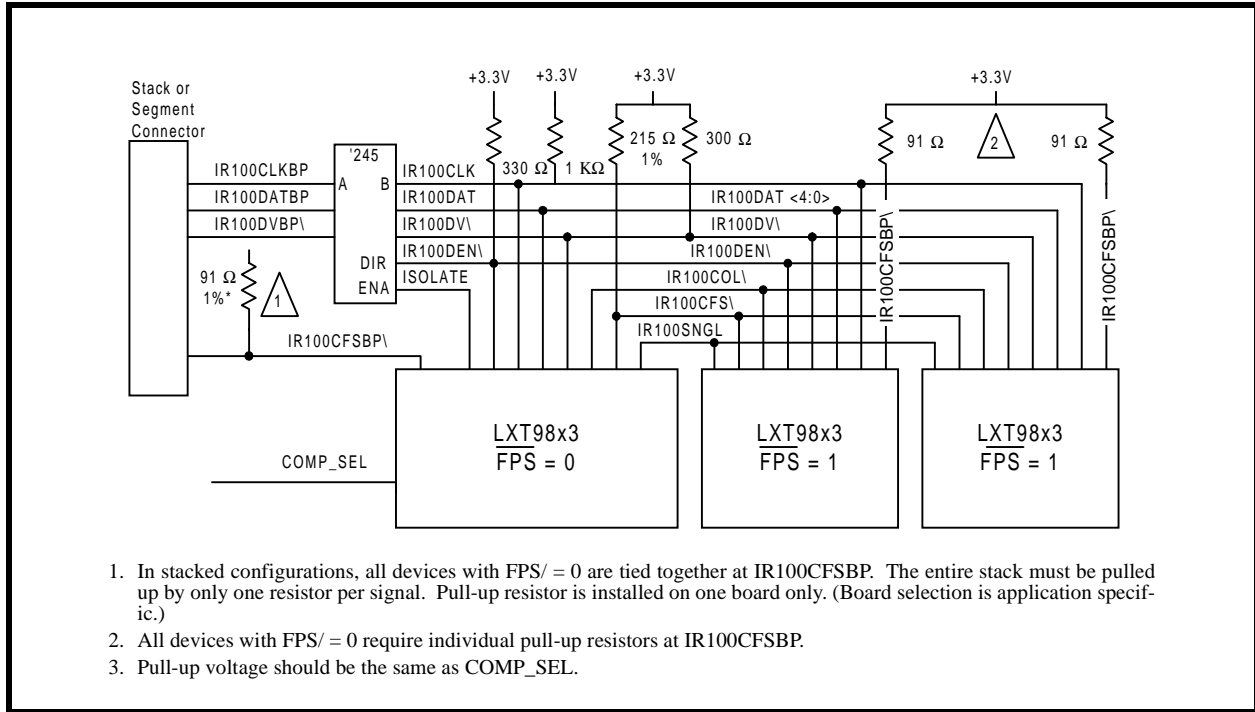
Stacking boards designed for 5V backplane operation with boards designed for 3.3V backplane operation causes network errors.

Figure 14: 100M Backplane Connection between LXT98x and LXT98x3

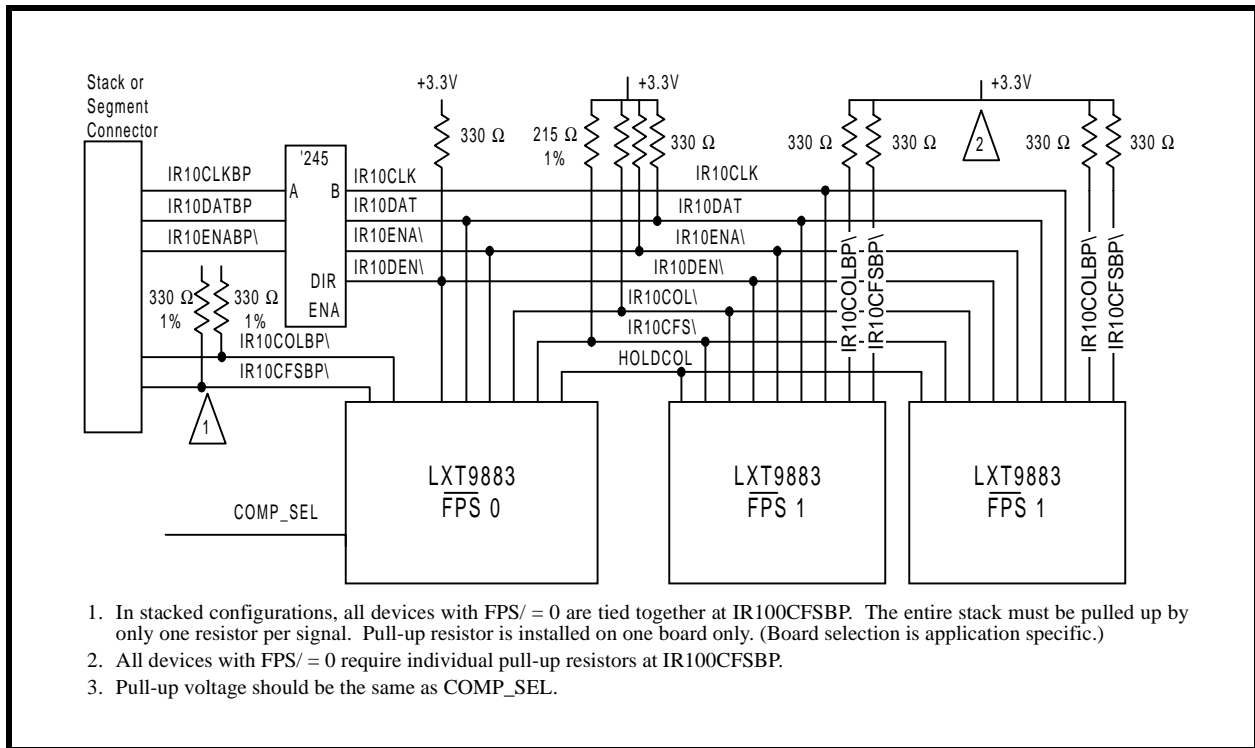




**Figure 15: Typical 100 Mbps IRB Implementation**



**Figure 16: Typical 10 Mbps IRB Implementation**



## TEST SPECIFICATIONS - PRELIMINARY

### NOTE

Table 19 through 34 and Figure 17 through 24 represent the target specifications of the LXT98x3 and are subject to change. Final values will be guaranteed by test except, where noted, by design. The minimum and maximum values listed in Table 21 through 34 will be guaranteed over the recommended operating conditions specified in Table 20.

**Table 19: Absolute Maximum Ratings**

Parameter		Symbol	Min	Max	Units
Supply voltage		VCC	-0.3	TBD	V
Operating temperature	Ambient	TOPA	-15	+85	°C
	Case	TOPC	–	+120	°C
Storage temperature		TST	-65	+150	°C
<b>CAUTION</b>					
Exceeding these values may cause permanent damage. Functional operation under these conditions is not implied. Exposure to maximum rating conditions for extended periods may affect device reliability.					

**Table 20: Operating Conditions**

Parameter		Sym	Min	Typ <sup>1</sup>	Max	Units
Recommended supply voltage		VCC	3.15	3.3	3.45	V
		VCCR	3.15	3.3	3.45	V
		VCCT	3.15	3.3	3.45	V
Recommended operating temperature	Ambient	TOPA	0	–	70	°C
	Case	TOPC	0	–	115	°C
Power consumption	Auto-Negotiation	PC	–	–	3.5	W
	100BASE-TX, 6/8 ports active	PC	–	–	3.5	W
	10BASE-T, 6/8 ports active	PC	–	–	3.4	W
1. Typical values are at 25° C and are for design aid only; they are not guaranteed and not subject to production testing.						

**Table 21: Input System Clock<sup>1</sup> Requirements**

Parameter <sup>2</sup>	Symbol	Min	Typ <sup>3</sup>	Max	Units	Test Conditions
Frequency	–	–	25	–	MHz	–
Frequency Tolerance	–	–	–	±100	PPM	–
Duty Cycle	–	40	–	60	%	–
1. The system clock is CLK25 (Pin 54).						
2. These requirements apply to the external clock supplied to the LXT98x3, not to LXT98x3 test specifications.						
3. Typical values are at 25 °C and are for design aid only; not guaranteed and not subject to production testing.						

Table 22: I/O Electrical Characteristics

Parameter	Sym	Min	Typ <sup>1</sup>	Max	Units	Test Conditions
Input Low voltage	V <sub>IL</sub>	–	–	0.8	V	TTL inputs
		–	–	30	% V <sub>CC</sub>	CMOS inputs <sup>2</sup>
		–	–	1.0		Schmitt triggers <sup>3</sup>
Input High voltage	V <sub>IH</sub>	2.0	–	–	V	TTL inputs
		70	–	–	% V <sub>CC</sub>	CMOS inputs <sup>2</sup>
		V <sub>CC</sub> - 1.0	–	–	V	Schmitt triggers <sup>3</sup>
Hysteresis voltage	–	1.0	–	–	V	Schmitt triggers <sup>3</sup>
Output Low voltage	V <sub>OL</sub>	–	–	0.4	V	I <sub>OL</sub> = 1.6 mA
Output Low voltage (LED)	V <sub>OLL</sub>	–	–	1.0	V	I <sub>OLL</sub> = 10 mA
Output High voltage	V <sub>OH</sub>	2.2	–	–	V	I <sub>OH</sub> = 40 μA
Input Low current	I <sub>IL</sub>	-100	–	–	μA	–
Input High current	I <sub>IH</sub>	–	–	100	μA	–
Output rise / fall time	TRF	–	3	10	ns	C <sub>L</sub> = 15 pF

1. Typical values are at 25 °C and are for design aid only; not guaranteed and not subject to production testing.  
2. Does not apply to IRB pins. Refer to [Tables 23 and 24](#) for IRB I/O characteristics.  
3. Applies to RESET, CLK25, IR100SNG, IR100COL, IR100DV, IR100DAT<sub>n</sub>, IR100CLK, and IR10CLK pins.

Table 23: 100 Mbps IRB Electrical Characteristics

Parameter	Symbol	Min	Typ <sup>1</sup>	Max	Units	Test Conditions	
Output Low voltage	V <sub>OL</sub>	–	.3	.7	V	R <sub>L</sub> = 330 Ω	
Output rise or fall time	T <sub>RF</sub>	–	4	10	ns	CL = 15 pF	
Input High voltage	V <sub>IH</sub>	V <sub>CC</sub> - 2.0	–	–	V	CMOS inputs	
		V <sub>CC</sub> - 1.0	–	–	V	IR100CLK (Schmitt trigger)	
Input Low voltage	V <sub>IL</sub>	–	–	2.0	V	CMOS inputs	
		–	–	1.0		IR100CLK (Schmitt trigger)	
Hysteresis voltage	–	1.0	–	–	V	IR100CLK (Schmitt trigger)	
<b>3.3V Operation</b>							
IR100CFS current	single drive	–	–	6.8	–	mA	R <sub>L</sub> = 215 Ω
	collision	–	–	13.5	–	mA	R <sub>L</sub> = 215 Ω
IR100CFSBP current	single drive	–	–	16.1	–	mA	R <sub>L</sub> = 91 Ω <sup>2</sup>
	collision	–	–	31.8	–	mA	R <sub>L</sub> = 91 Ω <sup>2</sup>
IR100CFS/BP voltage	single drive	–	–	1.83	–	V	–
	collision	–	–	0.4	–	V	–
<b>5.0V Operation</b>							
IR100CFS current	single drive	–	–	N/A	–	mA	R <sub>L</sub> = 215 Ω
	collision	–	–	N/A	–	mA	R <sub>L</sub> = 215 Ω
IR100CFSBP current	single drive	–	–	24.2	–	mA	R <sub>L</sub> = 91 Ω <sup>2</sup>
	collision	–	–	42	–	mA	R <sub>L</sub> = 91 Ω <sup>2</sup>
IR100CFS/BP voltage	single drive	–	–	2.8	–	V	–
	collision	–	–	0.6	–	V	–
1. Typical values are at 25° C and are for design aid only; they are not guaranteed and not subject to production testing. 2. 91Ω resistors provide greater noise immunity. Systems using 91Ω resistors are backwards stackable with systems using 100Ω resistors.							

Table 24: 10 Mbps IRB Electrical Characteristics

Parameter	Symbol	Min	Typ <sup>1</sup>	Max	Units	Test Conditions	
Output Low voltage	V <sub>OL</sub>	0	.1	.4	V	R <sub>L</sub> = 330 Ω	
Output rise or fall time	T <sub>RF</sub>	–	4	10	ns	C <sub>L</sub> = 15 pF	
Input High voltage	V <sub>IH</sub>	V <sub>CC</sub> - 2.0	–	–	V	CMOS inputs	
		V <sub>CC</sub> - 2.0	–	–	V	IR10CLK (Schmitt trigger)	
Input Low voltage	V <sub>IL</sub>	–	–	2.0	V	CMOS inputs	
		–	–	1.0	V	IR10CLK (Schmitt trigger)	
Hysteresis voltage	–	0.5	–	–	V	IR10CLK (Schmitt trigger)	
<b>3.3V Operation</b>							
I <sub>IR10CFS</sub> current	single drive	–	–	6.8	–	mA	R <sub>L</sub> = 215 Ω
	collision	–	–	13.5	–	mA	R <sub>L</sub> = 215 Ω
I <sub>IR10CFSBP</sub> current	single drive	–	–	4.5	–	mA	R <sub>L</sub> = 330 Ω
	collision	–	–	8.8	–	mA	R <sub>L</sub> = 330 Ω
V <sub>IR10CFS/BP</sub> voltage	single drive	–	1.3	1.83	2.4	V	–
	collision	–	0.2	0.4	0.6	V	–
<b>5.0V Operation</b>							
I <sub>IR10CFS</sub> current	single drive	–	–	N/A	–	mA	R <sub>L</sub> = 215 Ω
	collision	–	–	N/A	–	mA	R <sub>L</sub> = 215 Ω
I <sub>IR10CFSBP</sub> current	single drive	–	–	7.0	–	mA	R <sub>L</sub> = 330 Ω
	collision	–	–	13.5	–	mA	R <sub>L</sub> = 330 Ω
V <sub>IR10CFS/BP</sub> voltage	single drive	–	1.9	2.8	3.2	V	–
	collision	–	0.4	0.6	0.8	V	–
1. Typical values are at 25° C and are for design aid only; they are not guaranteed and not subject to production testing.							

**Table 25: 100BASE-TX Transceiver Electrical Characteristics**

Parameter	Symbol	Min	Typ <sup>1</sup>	Max	Units	Test Conditions
Peak differential output voltage (single ended)	VP	0.95	1.0	1.05	V	Note 2
Signal amplitude symmetry	–	98	–	102	%	Note 2
Signal rise/fall time	TRF	3.0	–	5.0	ns	Note 2
Rise/fall time symmetry	TRFS	–	–	0.5	ns	Note 2
Duty cycle distortion	–	–	–	+/- 0.5	ns	Offset from 8 ns pulse width at 50% of pulse peak,
Overshoot	VO	–	–	5	%	–

1. Typical values are at 25 °C and are for design aid only; not guaranteed and not subject to production testing.  
2. Measured at line side of transformer, line replaced by 100Ω (±1%) resistor.

**Table 26: 10BASE-T Transceiver Electrical Characteristics**

Parameter	Symbol	Min	Typ <sup>1</sup>	Max	Units	Test Conditions
<b>Transmitter</b>						
Peak differential output voltage	VP	2.2	2.5	2.8	V	Measured at line side of transformer, line replaced by 100Ω (±.1%) resistor
Transmit timing jitter addition <sup>2</sup>	–	8	–	24	ms	0 line length for internal MAU
Transmit timing jitter added by the MAU and PLS sections <sup>2, 3</sup>	–	0	–	11	ns	After line model specified by IEEE 802.3 for 10BASE-T internal MAU
<b>Receiver</b>						
Receive input impedance	ZIN	–	20	–	kΩ	Between TPIP/TPIN
Differential Squelch Threshold	VDS	–	390	–	mV	5 MHz square wave input, 750 mVpp

1. Typical values are at 25 °C and are for design aid only; not guaranteed and not subject to production testing.  
2. Parameter is guaranteed by design; not subject to production testing.  
3. IEEE 802.3 specifies maximum jitter additions at 1.5 ns for the AUI cable, 0.5 ns from the encoder, and 3.5 ns from the MAU.

Figure 17: 100 Mbps TP Port-to-Port Delay Timing

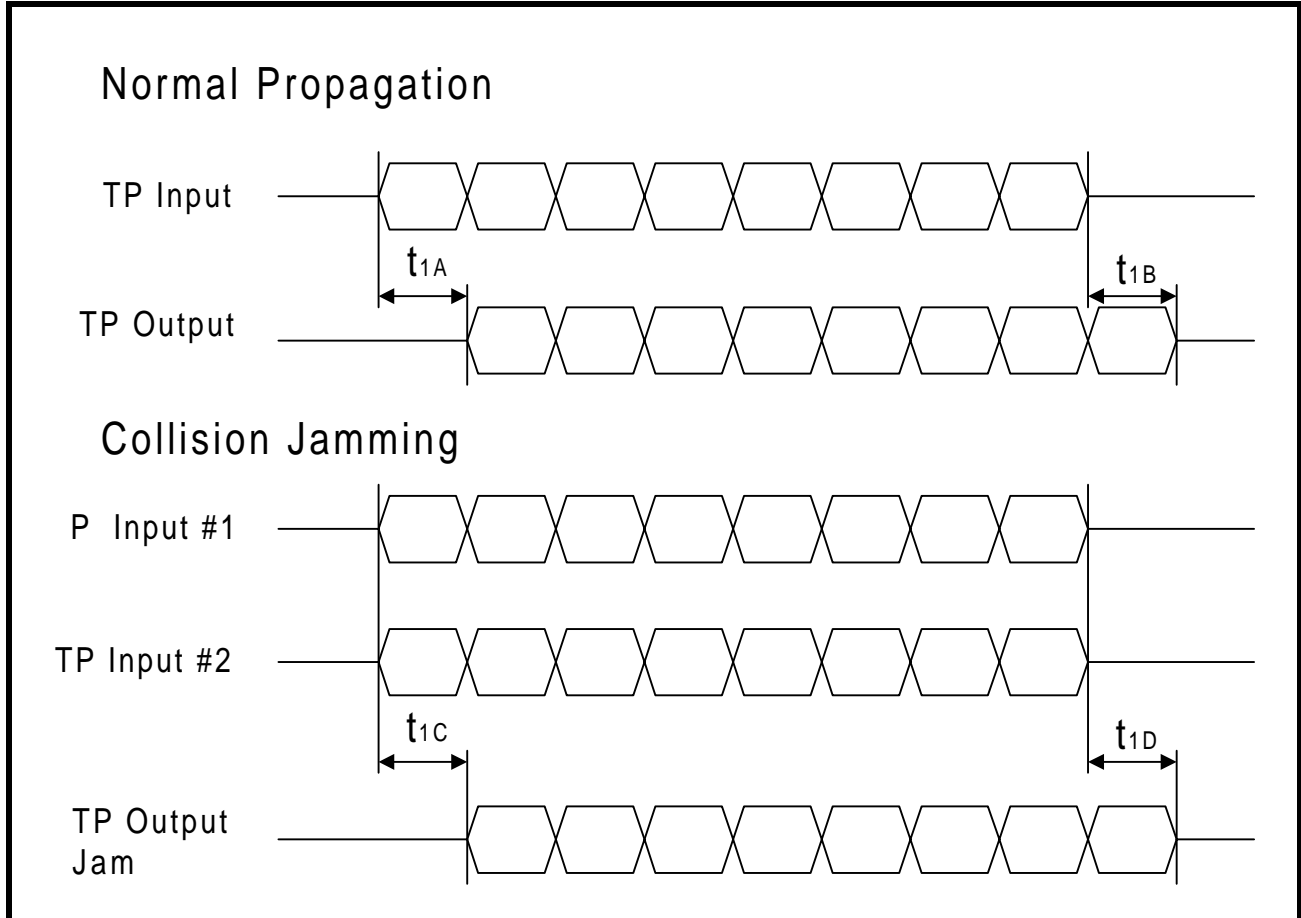
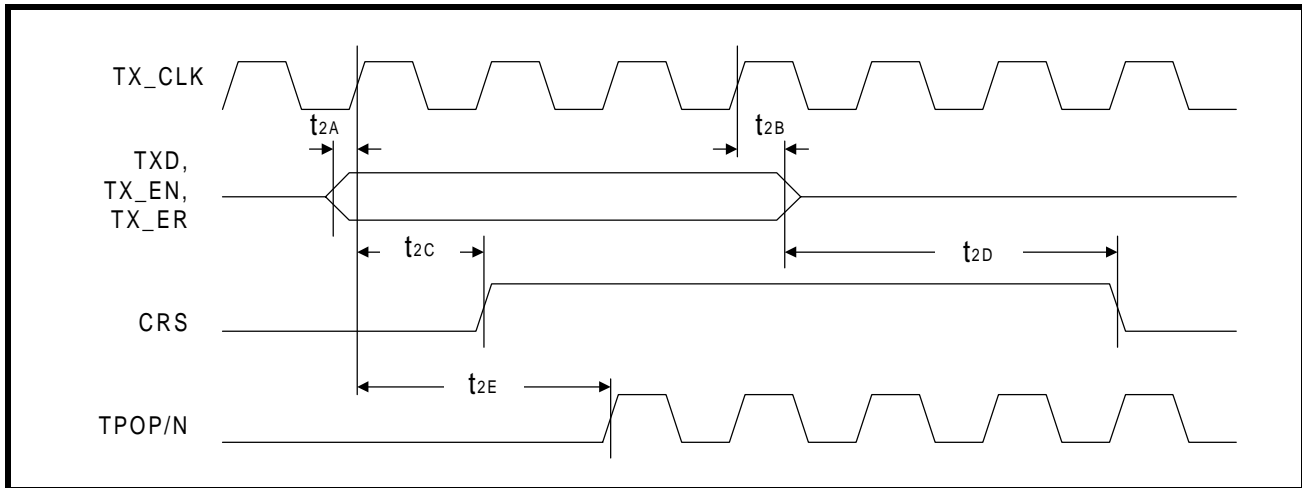


Table 27: 100 Mbps TP Port-to-Port Delay Timing Parameters

Parameter	Symbol	Min	Typ <sup>1</sup>	Max	Units <sup>2</sup>	Test Conditions
TPIP/N to TPOP/N, start of transmission	$t_{1A}$	–	–	46	BT	–
TPIP/N to TPOP/N, end of transmission	$t_{1B}$	–	–	46	BT	–
TPIP/N collision to TPOP/N, start of jam	$t_{1C}$	–	–	46	BT	–
TPIP/N idle to TPOP/N, end of jam	$t_{1D}$	–	–	46	BT	–

1. Typical values are at 25 °C and are for design aid only; not guaranteed and not subject to production testing.

2. Bit Time (BT) is the duration of one bit as transferred to/from the MAC and is the reciprocal of bit rate. BT for 100BASE-T =  $10^{-8}$  s or 10 ns.

**Figure 18: 100BASE-TX MII-to-TP Port Timing****Table 28: 100BASE-TX MII-to-TP Port Timing Parameters**

Parameter	Sym	Min	Typ <sup>1</sup>	Max	Units <sup>2</sup>	Test Condition
TXD, TX_EN, TX_ER Setup to TX_CLK High	t2A	10	–	–	ns	–
TXD, TX_EN, TX_ER Hold from TX_CLK High	t2B	5	–	–	ns	–
TX_EN sampled to CRS asserted	t2C	0	–	4	BT	–
TX_EN sampled to CRS de-asserted	t2D	0	–	16	BT	–
TX_EN sampled to TPOP/N active (Tx latency)	t2E	–	–	46	BT	–

1. Typical values are at 25 °C and are for design aid only; not guaranteed and not subject to production testing.  
 2. Bit Time (BT) is the duration of one bit as transferred to/from the MAC and is the reciprocal of bit rate. BT for 100BASE-T = 10<sup>-8</sup> s or 10 ns.



Figure 19: 100BASE-TX TP-to-MII Timing

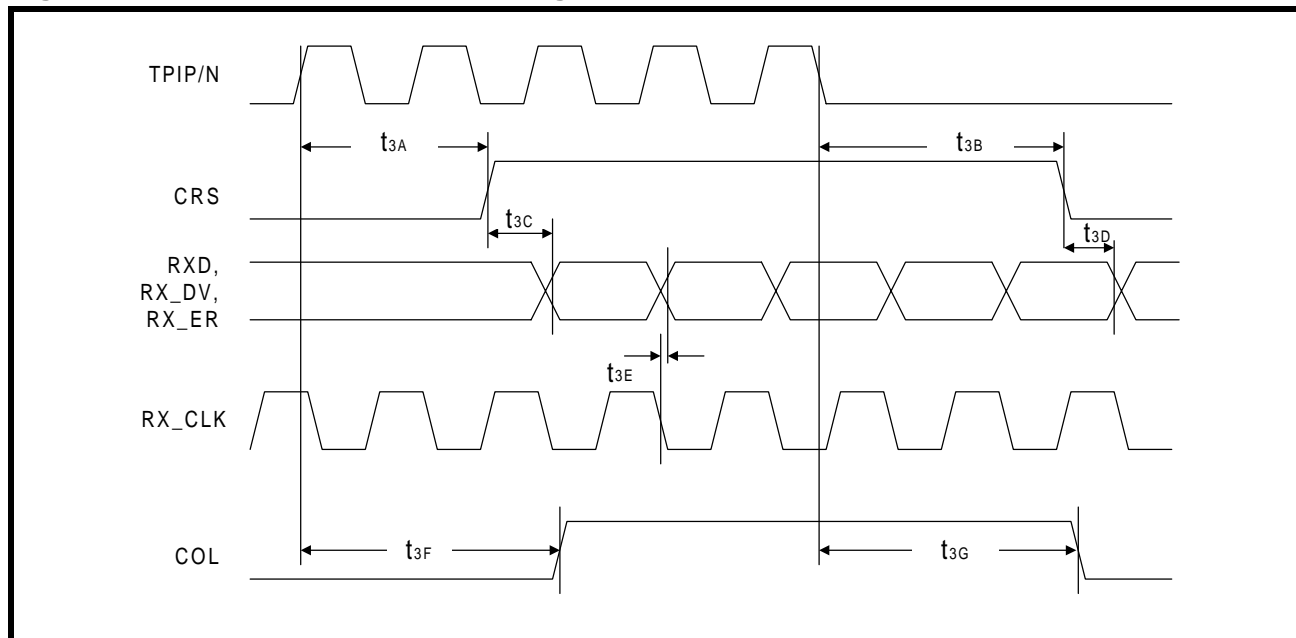


Table 29: 100BASE-TX TP-to-MII Timing Parameters

Parameter	Sym	Min	Typ <sup>1</sup>	Max	Units <sup>2</sup>	Test Conditions
TPIP/N in to CRS asserted	t3A	–	–	46	BT	–
TPIP/N quiet to CRS de-asserted	t3B	–	–	46	BT	–
CRS asserted to RXD, RX_DV, RX_ER	t3C	1	–	4	BT	–
CRS de-asserted to RXD, RX_DV, RX_ER de-asserted	t3D	–	–	3	BT	–
RX_CLK falling edge to RXD, RX_DV, RX_ER valid	t3E	–	–	10	ns	–
TPIP/N in to COL asserted	t3F	–	–	46	BT	–
TPIP/N quiet to COL de-asserted	t3G	–	–	46	BT	–

1. Typical values are at 25 °C and are for design aid only; not guaranteed and not subject to production testing.  
 2. Bit Time (BT) is the duration of one bit as transferred to/from the MAC and is the reciprocal of bit rate. BT for 100BASE-T = 10<sup>-8</sup> s or 10 ns.

Figure 20: 10BASE-T MII-to-TP Timing

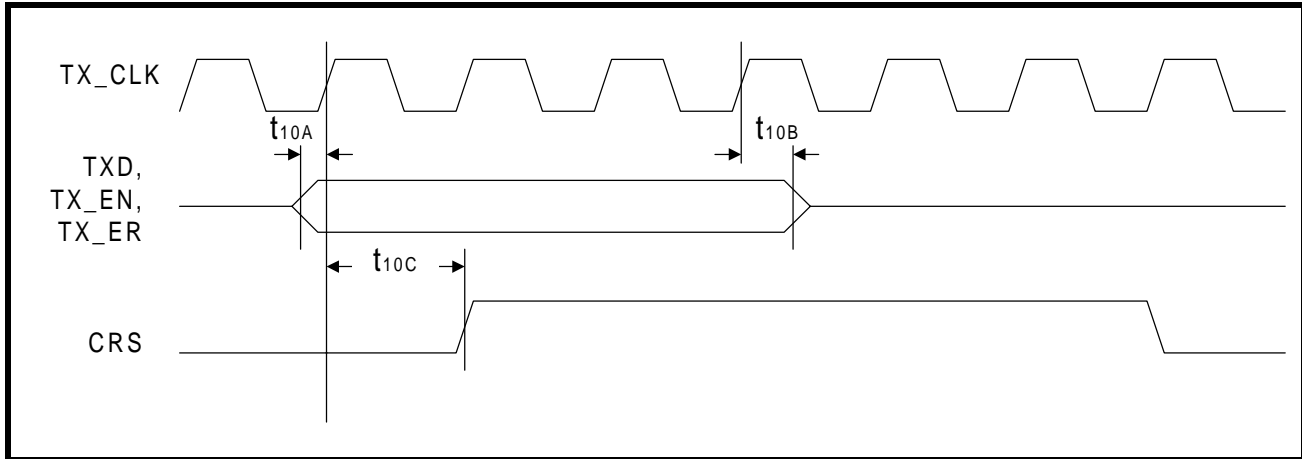


Table 30: 10BASE-T MII-to-TP Timing Parameters

Parameter	Sym	Min	Typ <sup>1</sup>	Max	Units <sup>2</sup>	Test Conditions
TXD, TX_EN, TX_ER Setup to TX_CLK High	t10A	10	–	–	ns	–
TXD, TX_EN, TX_ER Hold from TX_CLK High	t10B	5	–	–	ns	–
TX_EN sampled to CRS asserted	t10C	0	.9	2	BT	–

1. Typical values are at 25 °C and are for design aid only; not guaranteed and not subject to production testing.  
 2. Bit Time (BT) is the duration of one bit as transferred to/from the MAC and is the reciprocal of bit rate. BT for 10BASE-T = 10<sup>-7</sup> s or 100 ns.

Figure 21: 10BASE-T TP-to-MII Port Timing

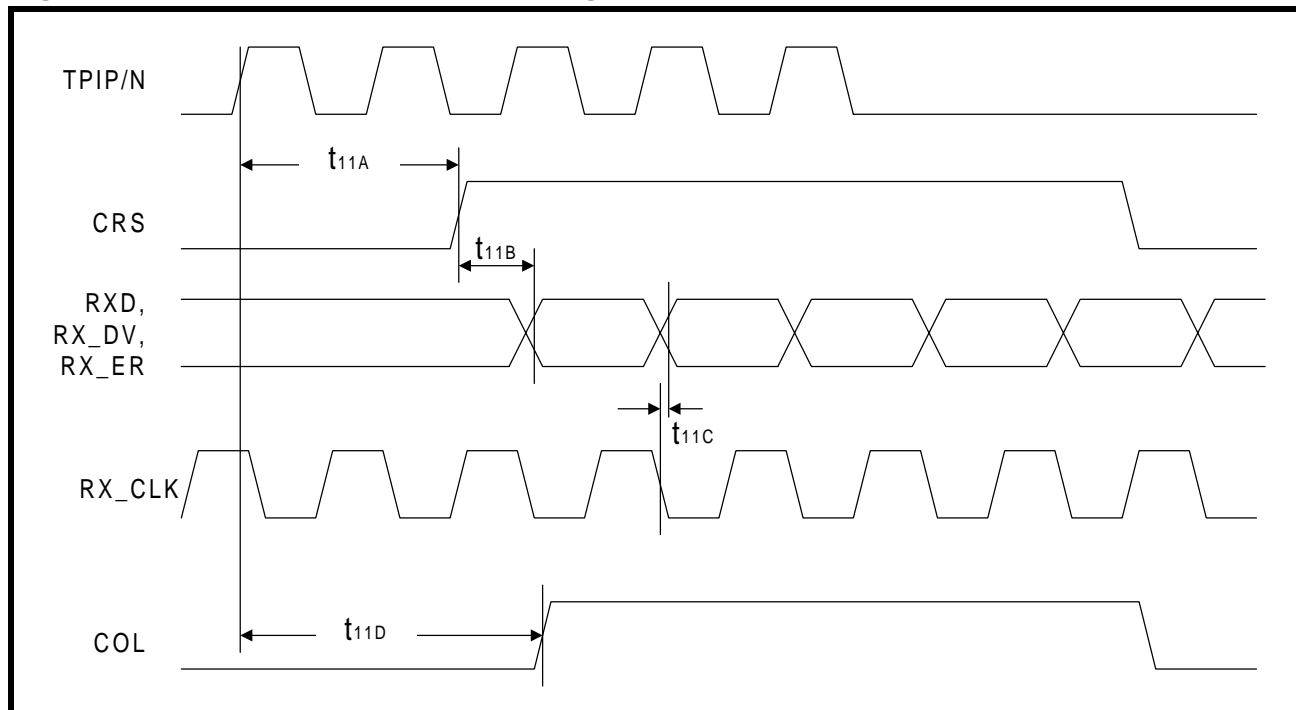
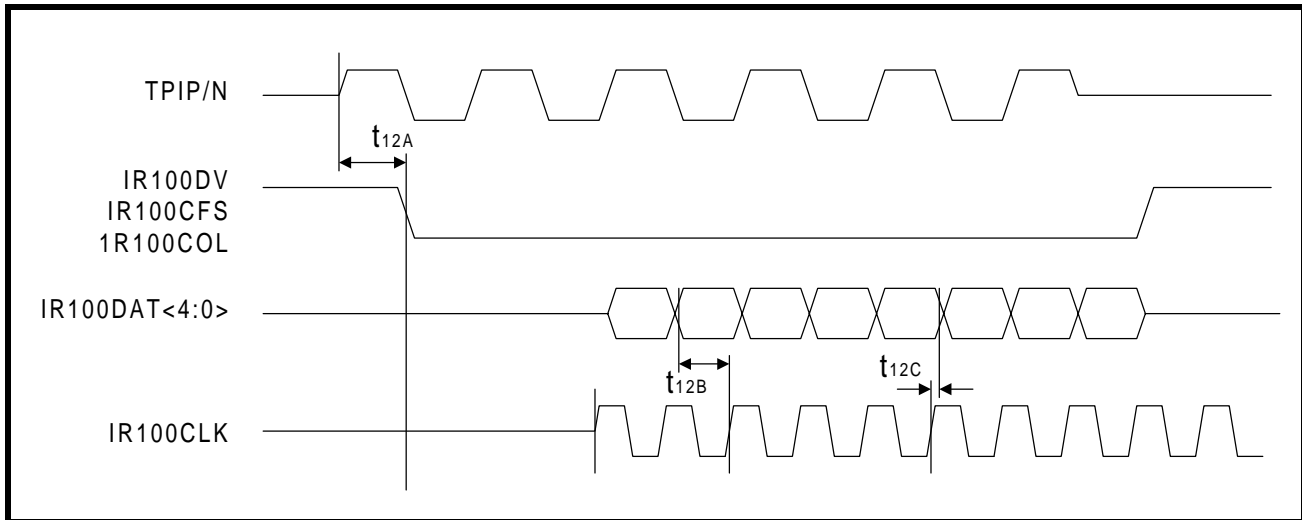


Table 31: 10BASE-T TP-to-MII Port Timing Parameters

Parameter	Sym	Min	Typ <sup>1</sup>	Max	Units <sup>2</sup>	Test Conditions
TPIP/N in to CRS asserted	t11A	5	6.6	8	BT	–
CRS asserted to RXD, RX_DV, RX_ER	t11B	70	76	84	BT	–
RX_CLK falling edge to RXD, RX_DV, RX_ER valid	t11C	–	–	10	ns	–
TPIP/N in to COL asserted	t11D	6	7.4	9	BT	–

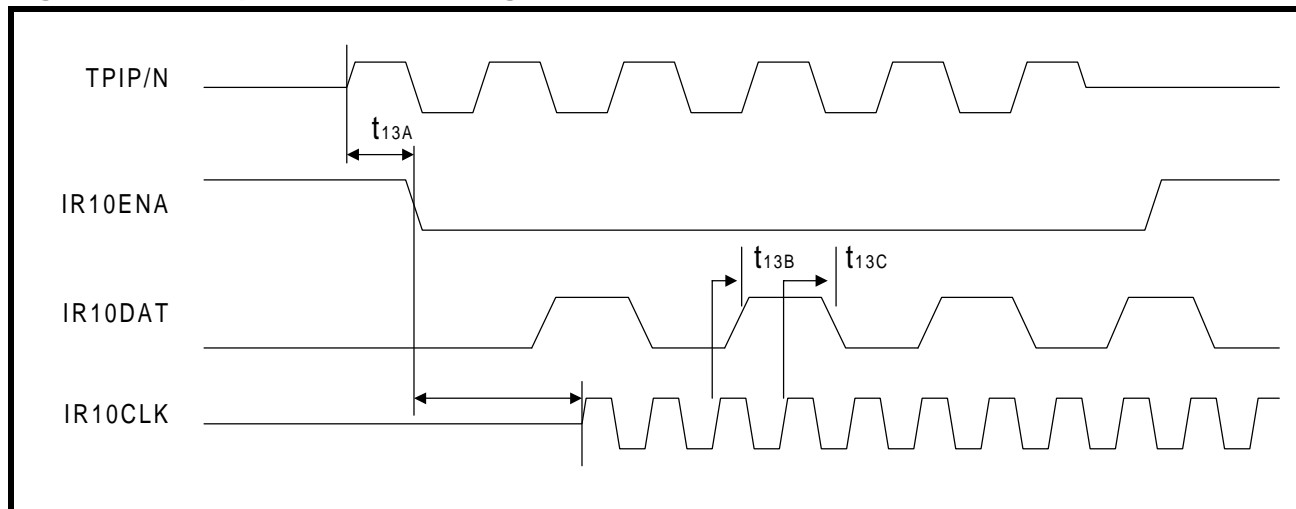
1. Typical values are at 25 °C and are for design aid only; not guaranteed and not subject to production testing.  
2. Bit Time (BT) is the duration of one bit as transferred to/from the MAC and is the reciprocal of bit rate. BT for 10BASE-T = 10<sup>-7</sup> s or 100 ns.

Figure 22: 100 Mbps TP-to-IRB Timing

Table 32: 100 Mbps TP-to-IRB Timing Parameters<sup>1</sup>

Parameter	Symbol	Min	Typ <sup>2</sup>	Max	Units <sup>3</sup>	Test Conditions
TPIP/N to $\overline{\text{IR100DV}}$ Low	t <sub>12A</sub>	18	24	30	BT	–
IR100DAT to IR100CLK setup time.	t <sub>12B</sub>	–	10	–	ns	–
IR100DAT to IR100CLK hold time.	t <sub>12C</sub>	–	0	–	ns	–

1. This table contains propagation delays from the TP ports to the IRB for normal repeater operation. All values in this table are output timings.  
2. Typical figures are at 25 C and are for design aid only; not guaranteed and not subject to production testing.  
3. Bit Time (BT) is the duration of one bit as transferred to/from the MAC and is the reciprocal of bit rate. BT for 100BASE-T = 10<sup>-8</sup> s or 10 ns.

**Figure 23: 10 Mbps TP-to-IRB Timing****Table 33: 10 Mbps TP-to-IRB Timing Parameters<sup>1</sup>**

Parameter <sup>2</sup>	Symbol	Min	Typ <sup>3</sup>	Max	Units <sup>4</sup>	Test Conditions
TPIP/N to IR10EN $\bar{A}$ Low	t <sub>13A</sub>	3	5.1	7	BT	—
IR10CLK rising edge to IR10DAT rising edge.	t <sub>13B</sub>	25	-	55	ns	330 $\Omega$ pull-up, 150 pF load on IR10DAT. 1 k $\Omega$ pull-up, 150 pF load on IRCLK.
IR10CLK rising edge to IR10DAT falling edge.	t <sub>13C</sub>	5	-	25	ns	

1. This table contains propagation delays from the TP ports to the IRB for normal repeater operation. All values in this table are output timings.
2. There is a delay of approximately 13 to 16 bit times between the assertion of IR10EN $\bar{A}$  and the assertion of IR10CLK and IR10DAT. This delay does not affect repeater operation because downstream devices begin generating preamble as soon as IR10EN $\bar{A}$  is asserted.
3. Typical values are at 25 °C and are for design aid only; not guaranteed and not subject to production testing.
4. Bit Time (BT) is the duration of one bit as transferred to/from the MAC and is the reciprocal of bit rate. BT for 10BASE-T = 10<sup>-7</sup> s or 100 ns.

Figure 24: 10 Mbps IRB-to-TP Port Timing

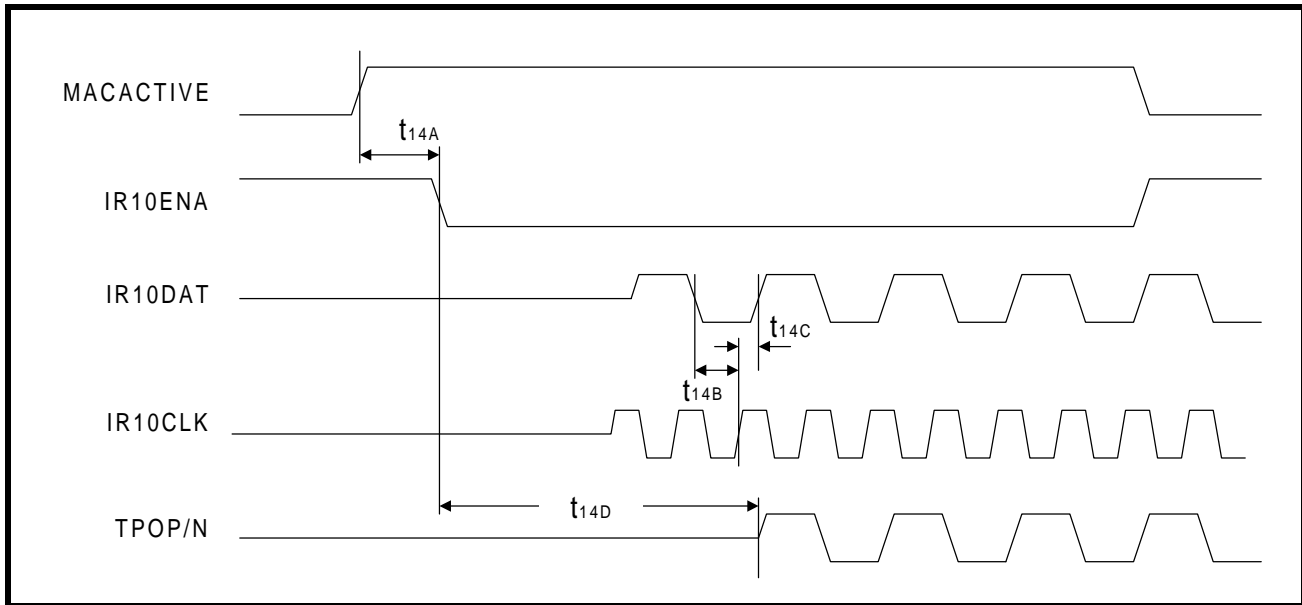


Table 34: 10 Mbps IRB-to TP Port Timing Parameters

Parameter	Symbol	Min	Typ <sup>1</sup>	Max	Units <sup>2</sup>	Test Conditions
MACACTIVE to IR10ENA assertion delay <sup>3</sup>	t14A	–	100	–	ns	MACACTIVE High to IR10ENA Low. <sup>4</sup>
IR10DAT (input) to IR10CLK setup time	t14B	–	20	–	ns	IR10DAT valid to IR10CLK rising edge. <sup>4</sup>
IR10CLK to IR10DAT (input) hold time	t14C	–	0	–	ns	IR10CLK rising edge to IR10DAT change. <sup>4</sup>
IR10ENA asserted to TPOP/N active	t14D	5	5.1	6	BT	–

1. Typical values are at 25° C and are for design aid only; they are not guaranteed and not subject to production testing.

2. Bit Time (BT) is the duration of one bit as transferred to/from the MAC and is the reciprocal of bit rate. BT for 10BASE-T = 10<sup>-7</sup> s or 100 ns.

3. External devices should allow at least one 10 MHz clock cycle (10 ns) between assertion of MACACTIVE and IR10ENA.

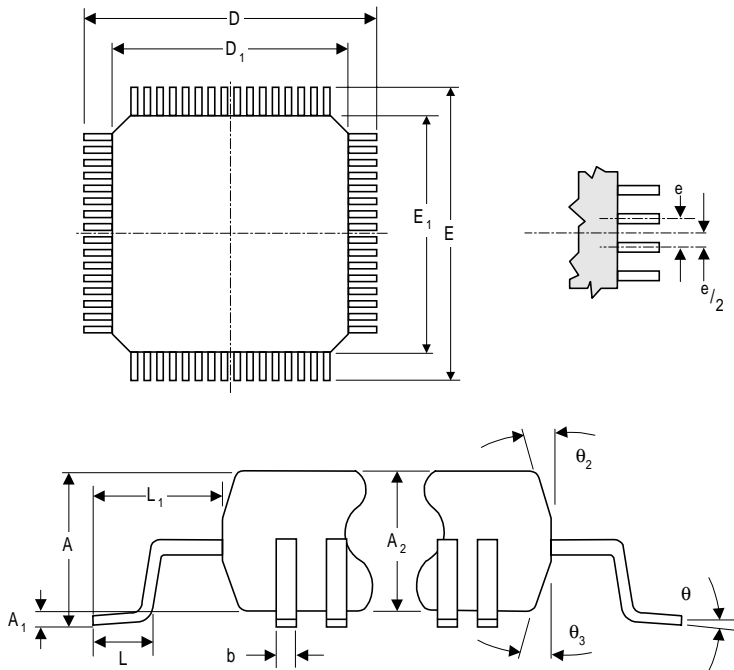
4. Input.

# MECHANICAL SPECIFICATIONS

Figure 25: LXT98x3 Package Specifications

### 208-Pin Plastic Quad Flat Package

- Part Numbers: LXT9883HC, LXT9863HC
- Commercial Temperature Range (0°C to 70°C)



Dim	Millimeters	
	Min	Max
A	-	4.10
A1	0.25	-
A2	3.20	3.60
b	0.17	0.27
D	30.30	30.90
D <sub>1</sub>	27.70	28.30
E	30.30	30.90
E <sub>1</sub>	27.70	28.30
e	.50 BASIC	
L	0.50	0.75
L <sub>1</sub>	1.30 REF	
q	0°	7°
θ <sub>2</sub>	5°	16°
θ <sub>3</sub>	5°	16°

## Corporate Headquarters

9750 Goethe Road  
 Sacramento, California 95827  
 Telephone: (916) 855-5000  
 Web: www.level1.com



## The Americas

### EAST

#### Eastern Area Headquarters

234 Littleton Road, Unit 1A  
 Westford, MA 01886  
 USA  
 Tel: (978) 692-1193  
 Fax: (978) 692-1244

#### North Central Regional Office

One Pierce Place  
 Suite 500E  
 Itasca, IL 60143  
 USA  
 Tel: (630) 250-6044  
 Fax: (630) 250-6045

#### Southeastern Regional Office

One Copley Parkway  
 Suite 309  
 Morrisville, NC 27560  
 USA  
 Tel: (919) 463-0488  
 Fax: (919) 463-0486

### WEST

#### Western Area Headquarters

3375 Scott Blvd., #110  
 Santa Clara, CA 95054  
 USA  
 Tel: (408) 496-1950  
 Fax: (408) 496-1955

#### South Central Regional Office

800 E. Campbell Road  
 Suite 199  
 Richardson, TX 75081  
 USA  
 Tel: (972) 680-5207  
 Fax: (972) 680-5236

#### Southwestern Regional Office

28202 Cabot Road  
 Suite 300  
 Laguna Niguel, CA 92677  
 USA  
 Tel: (949) 365-5655  
 Fax: (949) 365-5653

#### Latin/South America

9750 Goethe Road  
 Sacramento, CA 95827  
 USA  
 Tel: (916) 855-5000  
 Fax: (916) 854-1102

## International

### ASIA/PACIFIC

#### Asia / Pacific Area Headquarters

101 Thomson Road  
 United Square #08-01  
 Singapore 307591  
 Thailand  
 Tel: +65 353 6722  
 Fax: +65 353 6711

#### Central Asia/Pacific Regional Office

12F-1, No. 128, Section 3,  
 Ming Sheng East Road  
 Taipei, Taiwan,  
 R.O.C.  
 Tel: +886 2 2547 5227  
 Fax: +886 2 2547 5228

#### Northern Asia/Pacific Regional Office

Shinjuku Tsuji Building, 2F  
 2-10-4, Yoyogi, Shibuya-Ku  
 Tokyo, 151-0053 Japan  
 Tel: 81-3-5333-1780  
 Fax: 81-3-5333-1785

### EUROPE

#### European Area HQ & Southern Regional Office

Parc Technopolis-Bat. Zeta 3,  
 avenue du Canada -  
 Z.A. de Courtaboeuf  
 Les Ulis Cedex 91974  
 France  
 Tel: +33 1 64 86 2828  
 Fax: +33 1 60 92 0608

#### Central Europe Regional Office

Lilienthalstr.25  
 D-85399  
 Hallbergmoos, Germany  
 Tel: +49-811-60068-0  
 Fax: +49-811-60068-15

#### Northern Europe Regional Office

Torshamnsgatan 35  
 164/40 Kista/Stockholm,  
 Sweden  
 Tel: +46 8 750 3980  
 Fax: +46 8 750 3982

#### Israel

#### Regional Office

Regus Instant Off.-Harel House  
 3 Abba Hillel Silver Street  
 Ramat Gan, 52522 Israel  
 Tel: +972-3-754-1130  
 Fax: +972-3-754-1100

<u>Revision</u>	<u>Date</u>	<u>Status</u>
1.0	05/00	Initial Release

Information in this document is provided in connection with Level One products. No license, express or implied, by estoppel or otherwise, to any intellectual property rights is granted by this document. Except as provided in Level One's Terms and Conditions of Sale for such products, Level One assumes no liability whatsoever, and Level One disclaims any express or implied warranty, relating to sale and/or use of Level One products including liability or warranties relating to fitness for a particular purpose, merchantability, or infringement of any patent, copyright or other intellectual property right. Level One products are not intended for use in medical, life saving, or life sustaining applications.

Level One may make changes to specifications and product descriptions at any time, without notice. Designers must not rely on the absence or characteristics of any features or instructions marked "reserved" or "undefined." Level One reserves these for future definition and shall have no responsibility whatsoever for conflicts or incompatibilities arising from future changes to them. Third party brands and names are the property of their respective owners.

The products listed in this publication are covered by one or more of the following patents. Additional patents pending.

5,008,637; 5,028,888; 5,057,794; 5,059,924; 5,068,628; 5,077,529; 5,084,866; 5,148,427; 5,153,875; 5,157,690; 5,159,291; 5,162,746; 5,166,635; 5,181,228; 5,204,880; 5,249,183; 5,257,286; 5,267,269; 5,461,661; 5,493,243; 5,534,863; 5,574,726; 5,581,585; 5,608,341; 5,666,129; 5,671,249; 5,701,099; 5,717,714; 5,742,603; 5,748,634; 5,764,638; 5,777,996; 5,802,052; 5,880,645; 5,881,074; 5,907,553; 5,926,049; 5,926,504; 5,946,398

Copyright © 2000 Level One Communications, Inc., an Intel Company. Specifications subject to change without notice. All rights reserved.