

## Contents

Revision History	(3)
General Description	(4)
General Information	(4)
1. Absolute Maximum Ratings	(5)
2. Optical Characteristics	(6)
3. Electrical Characteristics	(9)
3.1 TFT LCD Module	
3.2 Back Light Unit	
4. Block Diagram	(11)
5. Input Terminal Pin Assignment	(12)
5.1 Input Signal & Power	
5.2 Inverter Input Pin Configuration	
5.3 Inverter Input Power Sequence & Specification	
5.4 LVDS Interface	
5.5 Input Signals, Basic Display Colors and Gray Scale of Each Color	
6. EDID Information	(19)
6.1 EEPROM Data	
6.2 EEPROM Data Map	
7. Interface Timing	(21)
7.1 Timing Parameters (DE only mode)	
7.2 Timing Diagrams of interface Signal (DE only mode)	
7.3 Power ON/OFF Sequence	
8. Outline Dimension	(24)
9. EMI Specification	(26)
10. UL Approval	
11. Reliability Test	(27)
12. Packing	(28)
13. Marking & Others	(30)
14. General Precaution	(31)
14.1 Handling	
14.2 Storage	
14.3 Operation	
14.4 Operation Condition Guide	
14.5 Others	

**\* Revision History**

Date	Rev. No	Page	Summary									
Mar. 23, 2010	000	-	<p style="text-align: center;">First Issued  <b>SESL 向 MODEL : LTY[Z]320HM03-A02</b>  <b>SELSK 向 MODEL : LTY[Z]320HM03-A03</b></p>									
Sep. 17, 2010	001	-	<p>- To Secure the mass production  <b>Model Code Added : LTY[Z]320HM03-A05</b></p> <table border="1" data-bbox="461 647 1035 804"> <thead> <tr> <th data-bbox="461 647 652 703">Rev. Code</th> <th data-bbox="652 647 844 703">OLB</th> <th data-bbox="844 647 1035 703">Assy</th> </tr> </thead> <tbody> <tr> <td data-bbox="461 703 652 759">A02</td> <td data-bbox="652 703 844 759">SESL</td> <td data-bbox="844 703 1035 759">SESL</td> </tr> <tr> <td data-bbox="461 759 652 804">A05</td> <td data-bbox="652 759 844 804">TJ</td> <td data-bbox="844 759 1035 804">DS</td> </tr> </tbody> </table>	Rev. Code	OLB	Assy	A02	SESL	SESL	A05	TJ	DS
Rev. Code	OLB	Assy										
A02	SESL	SESL										
A05	TJ	DS										

## General Description

### Description

LTY[Z]320HM03 is a color active matrix liquid crystal display (LCD) that uses amorphous silicon TFT (Thin Film Transistor) as switching components. This model is composed of a TFT LCD panel, a driver circuit and a back light unit. The resolution of a 32.0" is 1920 x 1080 and this model can display up to 16.7 million colors with wide viewing angle of 89° or higher in all directions. This panel is intended to support applications to provide an excellent performance for Flat Panel Display such as Home-alone Multimedia TFT-LCD TV, Display terminals for AV application products, and High Definition TV (HDTV).

### Features

- RoHS compliance (Pb-free)
- High contrast ratio, high aperture ratio, fast response time
- SPVA (Super Patterned Vertical Align) mode
- Wide viewing angle ( $\pm 89^\circ$ )
- Full HD (1920 x 1080 pixels) resolution (16:9)
- Low Power consumption
- 4 CCFTs (Cold Cathode Fluorescent Tube)
- LVDS (Low Voltage Differential Signaling) interface

## General Information

Items	Specification	Unit	Note
Module Size	960(H <sub>TYP</sub> ) x 450(V <sub>TYP</sub> )	mm	$\pm 1.0$ mm
	57.2(D <sub>MAX</sub> )		
Weight	6000(Max)	g	
Pixel Pitch	0.12125(H) * 3 x 0.36375(V)	mm	
Active Display Area	698.4(H) x 392.85(V)	mm	
Surface Treatment	Haze 7%, Hard-coating (3H)		
Display Colors	8 bit- 16.7M	colors	
Number of Pixels	1920 x 1080	pixel	
Pixel Arrangement	RGB vertical stripe		
Display Mode	Normally Black		
Luminance of White	400	cd/m <sup>2</sup>	Typ.

## 1. Absolute Maximum Ratings

If the condition exceeds maximum ratings, it can cause malfunction or unrecoverable damage to the device.

Item	Symbol	Min.	Max.	Unit	Note
Power Supply Voltage	$V_{DD}$	GND-0.5	13	V	(1)
Storage temperature	$T_{STG}$	-20	65	°C	(2)
Operating Temperature	$T_{OPR}$	0	50	°C	(2)
Panel surface temperature	$T_{SUR}$	0	65	°C	(3)
Shock ( non - operating )	$S_{NOP}$	-	50	G	(4)
Vibration ( non - operating )	$V_{NOP}$	-	1.5	G	(5)

Note (1)  $T_a = 25 \pm 2$  °C

(2) Temperature and relative humidity range are shown in the figure below.

a. 93.8 % RH Max. ( $T_a \leq 40$  °C)

b. Maximum wet-bulb temperature at 40 °C or less. ( $T_a \leq 40$  °C)

c. No condensation

(3) Polarizer will not be damaged in this range, even though abnormal visual problems occur in  $T_{SUR}$  range.

(4) 11ms, sine wave, one time for  $\pm X, \pm Y, \pm Z$  axis

(5) 10-300 Hz, Sweep rate 10min, 30min for X,Y,Z axis

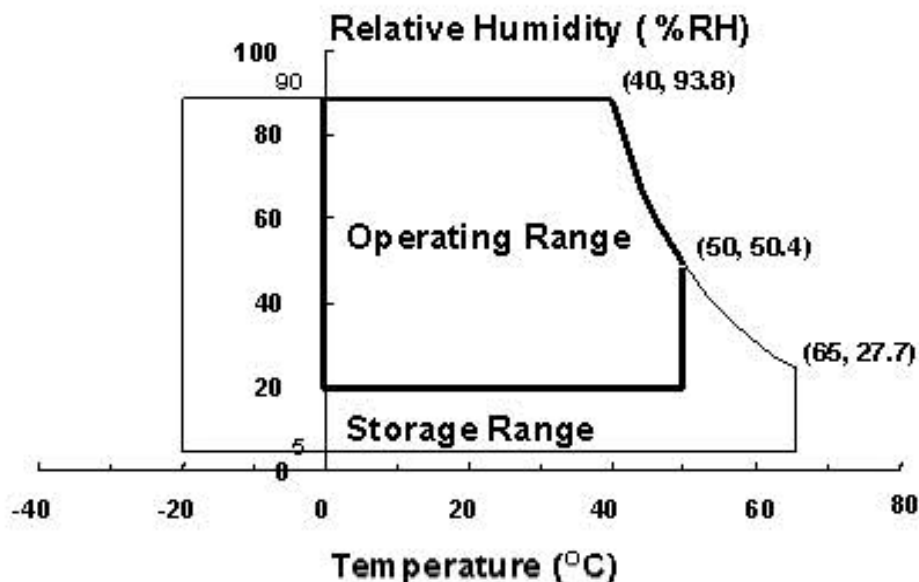

Fig. Temperature and Relative humidity range

## 2. Optical Characteristics

The optical characteristics should be measured in a dark room or equivalent.

Measuring equipment : TOPCON BM-7,SPECTRORADIOMETER SR-3

( $T_a = 25 \pm 2^\circ\text{C}$ ,  $V_{DD}=12\text{V}$ ,  $f_v=60\text{Hz}$ ,  $f_{DCLK}=148.5\text{MHz}$ ,  $\text{Dim} = 100\%$ )

Item	Symbol	Condition	Min.	Typ.	Max.	Unit	Note	
Contrast Ratio (Center of screen)	C/R		*2000	5000	-		(3) SR-3	
Response Time	Rising	Tr	-	12	70	msec	(5) BM-7	
	Falling	Tf	-	8	18			
	G-to-G [AVE]	Tg	-	8	-			
Luminance of White (Center of screen)	$Y_L$	Normal $\theta_L, R=0$ $\theta_U, D=0$	330	400	-	cd/m <sup>2</sup>	(6) SR-3	
Color Chromaticity (CIE 1931)	Red	Rx	Viewing Angle	0.633	TYP. -0.03	TYP. +0.03	(7),(8) SR-3	
		Ry		0.325				
	Green	Gx		0.294				
		Gy		0.603				
	Blue	Bx		0.150				
		By		0.059				
	White	Wx		0.280				
		Wy		0.285				
Color Gamut	-		-	72	-	%	(7) SR-3	
Color Temperature	-		-	10000	-	K	(7) SR-3	
Gamma	$\gamma$		-	2.2	-			
Viewing Angle	Hor.	$\theta_L$	C/R $\geq$ 10	79	89	-	Degree	(8) SR-3
		$\theta_R$		79	89	-		
	Ver.	$\theta_U$		79	89	-		
		$\theta_D$		79	89	-		
Brightness Uniformity (9 Points)	$B_{uni}$		-	-	25	%	(4) SR-3	

\* marked Items Value does not Specification above when "White stain" occurs at Center Point [Point ⑤ of Note 2.]

### Note (1) Test Equipment Setup

The measurement should be executed in a stable, windless and dark room between 40min and 60min after lighting the back light at the given temperature for stabilization of the back light. This should be measured in the center of screen.

Single lamp current @  $V_{dim} = 100\%$

Environment condition :  $T_a = 25 \pm 2^\circ\text{C}$

MODEL

LTY[Z]320HM03

Doc. No

05-001-S-100917

Page

6 / 33

Photo detector	Field
SR-3	1°
BM-7	2°

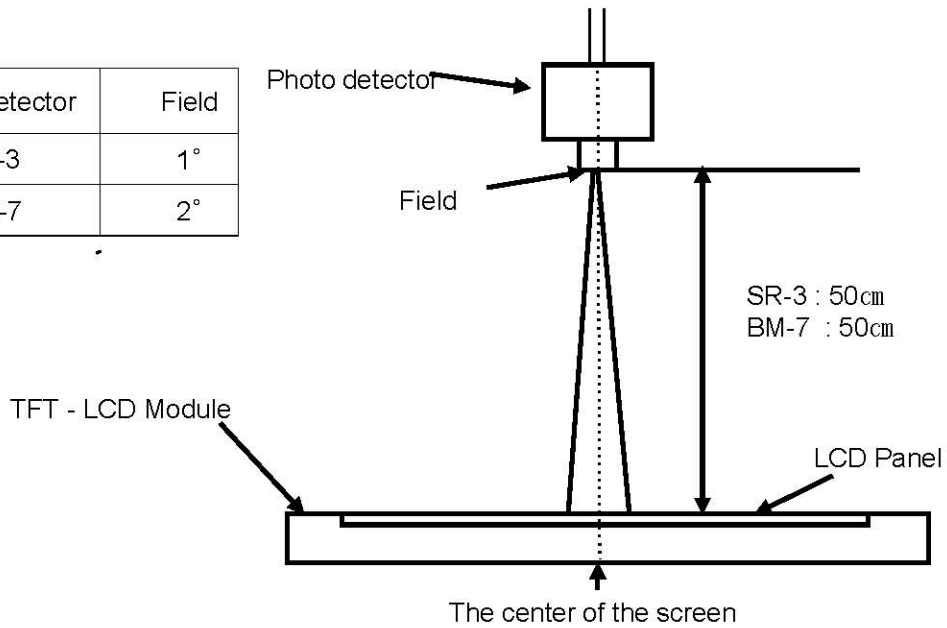

Note (2) Definition of test point

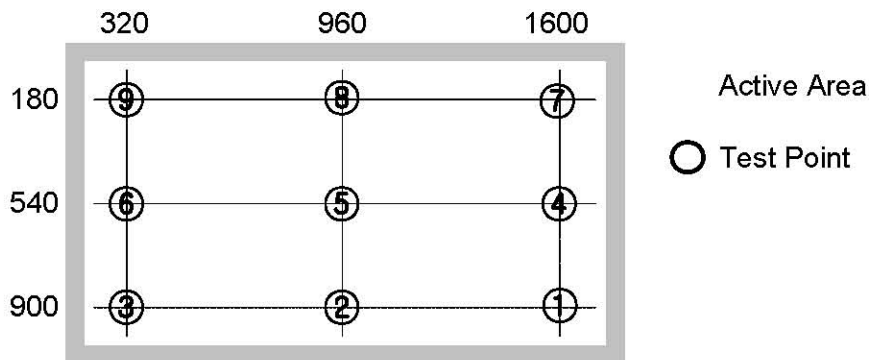

Note (3) Definition of Contrast Ratio (C/R)

: Ratio of gray max (Gmax) & gray min (Gmin) at the center point ⑤ of the panel

$$C/R = \frac{G_{\max}}{G_{\min}}$$

Gmax : Luminance with all pixels white

Gmin : Luminance with all pixels black

Note (4) Definition of 9 points brightness uniformity

$$B_{uni} = 100 \times \frac{(B_{max} - B_{min})}{B_{max}}$$

Bmax : Maximum brightness

Bmin : Minimum brightness

Note (5) Definition of Response time : Sum of Tr, Tf

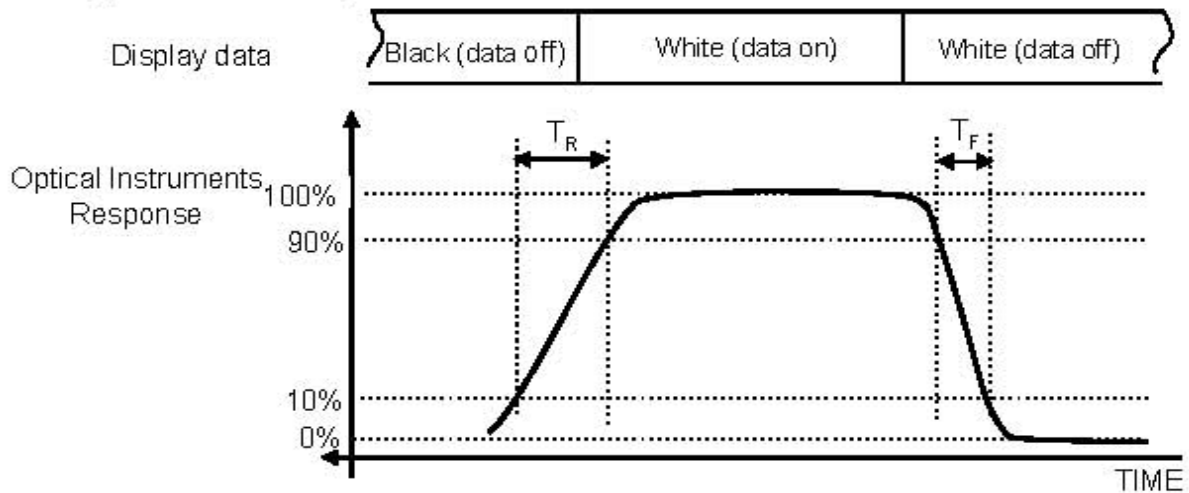

Note (6) Definition of Luminance of White : Luminance of white at center point ⑤

Note (7) Definition of Color Chromaticity (CIE 1931)

Color coordinate of Red, Green, Blue & White at center point ⑤

Note (8) Definition of Viewing Angle

∴ Viewing angle range ( $C/R \geq 10$ )

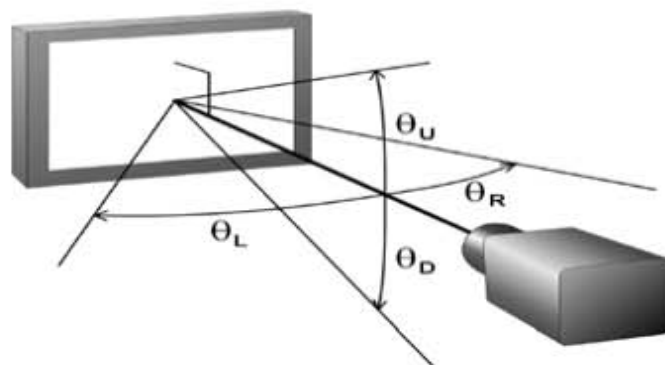

### 3. Electrical Characteristics

#### 3.1 TFT LCD Module

The connector for display data & timing signal should be connected.

$T_a = 25^\circ\text{C} \pm 2^\circ\text{C}$

Item	Symbol	Min.	Typ.	Max.	Unit	Note
Voltage of Power Supply	$V_{DD}$	11	12	13	V	(1)
Current of Power Supply	(a) Black	-	450	-	mA	(2),(3)
	(b) White	-	700	900		
	(c) Mosaic	-	700	-		
	(4) Max Pattern	-	750	950		
Vsync Frequency	$f_V$	47	60	62	Hz	
Hsync Frequency	$f_H$	50	67.5	73	kHz	
Main Frequency	$f_{DCLK}$	130	148.5	155	MHz	
Rush Current	$I_{RUSH}$	-	-	5	A	(4)

Note (1) The ripple voltage should be controlled under 10% of  $V_{DD}$ .

(2)  $f_V=60\text{Hz}$ ,  $f_{DCLK} = 148.5\text{MHz}$ ,  $V_{DD} = 12.0\text{V}$ , DC Current.

(3) Power dissipation check pattern (LCD Module only)

a) Black Pattern

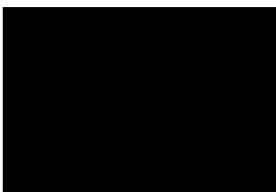

b) White Pattern



c) Mosaic

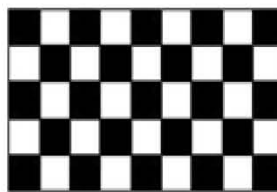

d)Max. Pattern

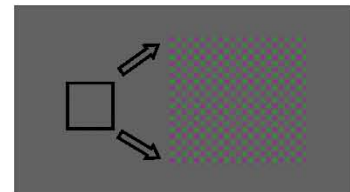

#### (4) Measurement Conditions

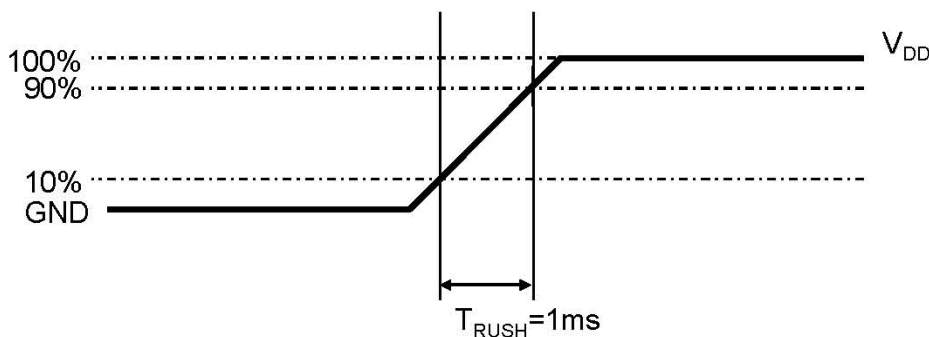

Rush Current  $I_{RUSH}$  can be measured when  $T_{RUSH}$  is 1ms



### 3.2 Back Light Unit

The back light unit contains 4 CCFTs ( Cold Cathode Fluorescent Tube ).  
 The characteristics of lamps are shown in the following tables.

Ta=25 ± 2°C

Item	Symbol	Min.	Typ.	Max.	Unit	Note
Operating Life Time	Hr	50,000	-	-	Hour	(1)
Lamp Current	Lc	11.0	-	16.0	mA	-

Note (1) It is defined as the time to take until the brightness reduces to 50% of its original value.

[Operating condition : Ta = 25±2°C, I<sub>L</sub> = 14.0 mA(typ.), For single lamp only. ]

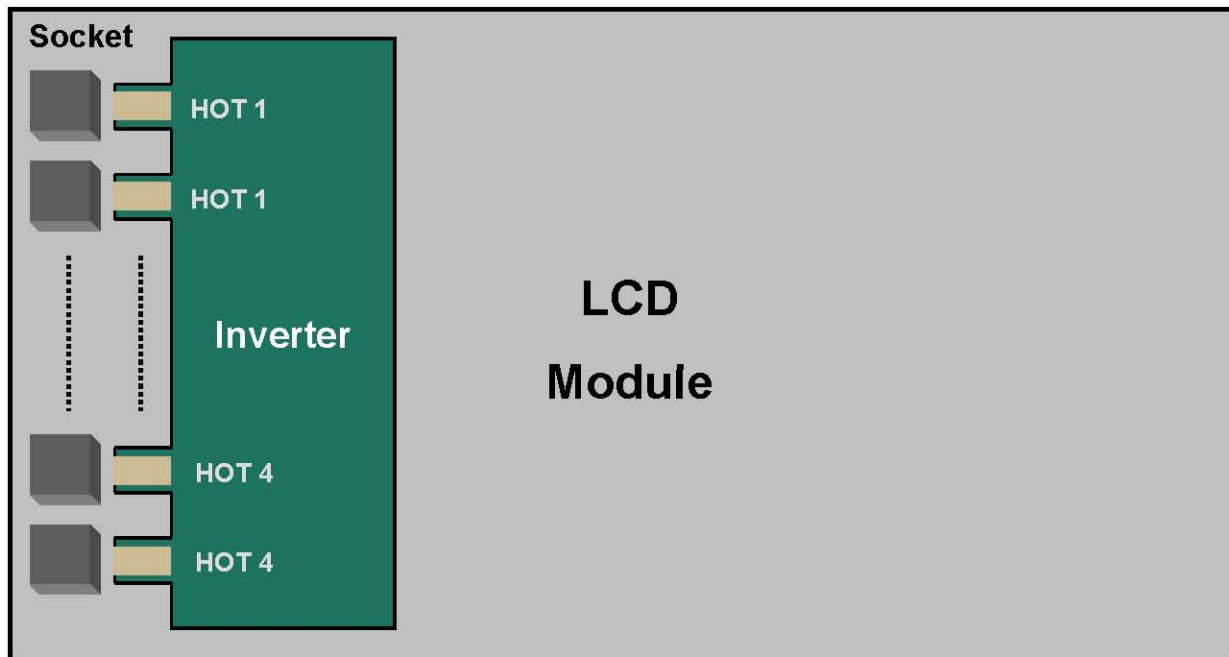

## 4. Block Diagram

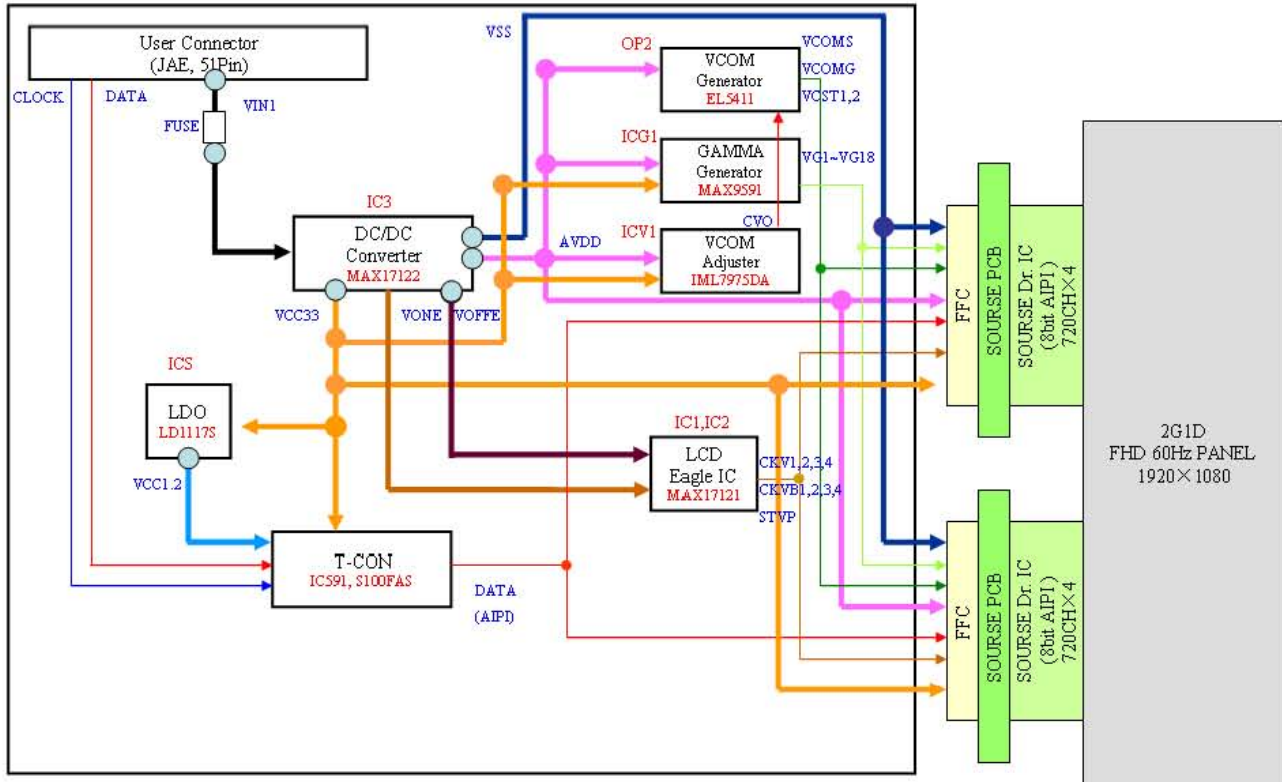

## 5. Input Terminal Pin Assignment

### 5.1. Input Signal & Power

Connector : IS050-C51B-C38(UJU)

Compatible with FI-RE51S-HF(JAE)

PIN No.	Signal	Description	PIN No.	Signal	Description
1	Power	V <sub>DD</sub>	26	LVE[0]P	Even LVDS Signal +
2	Power	V <sub>DD</sub>	27	LVE[1]N	Even LVDS Signal -
3	Power	V <sub>DD</sub>	28	LVE[1]P	Even LVDS Signal +
4	Power	V <sub>DD</sub>	29	LVE[2]N	Even LVDS Signal -
5	Power	V <sub>DD</sub>	30	LVE[2]P	Even LVDS Signal +
6	GND	GND	31	GND	GND
7	GND	GND	32	LVECLK-	Even LVDS Clock-
8	GND	GND	33	LVECLK+	Even LVDS Clock+
9	GND	GND	34	GND	GND
10	LVO[0]N	Odd LVDS Signal -	35	LVE[3]N	Even LVDS Signal -
11	LVO[0]P	Odd LVDS Signal +	36	LVE[3]P	Even LVDS Signal +
12	LVO[1]N	Odd LVDS Signal -	37	N.C.	No Connection
13	LVO[1]P	Odd LVDS Signal +	38	N.C.	No Connection
14	LVO[2]N	Odd LVDS Signal -	39	GND	GND
15	LVO[2]P	Odd LVDS Signal +	40	SCL	I2C SCL
16	GND	GND	41	SDA	I2C SDA
17	LVOCLK-	Odd LVDS CLK -	42	VSYNC	*V Sync Signal
18	LVOCLK+	Odd LVDS CLK +	43	B-INT	Bus Release
19	GND	GND	44	N.C.	No Connection
20	LVO[3]N	Odd LVDS Signal -	45	N.C.	No Connection
21	LVO[3]P	Odd LVDS Signal +	46	LUT SEL0	DCC LUT Select 0
22	N.C.	No Connection	47	LUT SEL1	DCC LUT Select1
23	N.C.	No Connection	48	LUT SEL2	DCC LUT Select2
24	GND	GND	49	HSYNC	H Sync Signal
25	LVE[0]N	Even LVDS Signal -	50	TCON_RDY	T-Con Ready
			51	SEL1	SEC Internal Use Only

■ B-INT : I2C BUS RELEASE

Operation	Description
LOW/OPEN	SDA/SCL LINE BECOME HI-Z
HIGH	USER CAN ACCESS EEPROM

■ DCC Look Up Table Selection

Pin N.O.	48	47	46	Description ( Based on DCC On)	
				LUT	%(For Interpolate)
Select bit	0	0	0	For 60Hz	100%
	0	0	1	For 60Hz	100%X1.25
	0	1	0	For 60Hz @ Low Temp.	100%X1.25
	0	1	1	For 60Hz @ Low Temp.	(100%X1.25) X 1.25
	1	0	0	For 50Hz	100%
	1	0	1	For 50Hz	100%X1.25
	1	1	0	0%	
	1	1	1		

■ TCON Ready

Operation	Description
Low → High	Normal Operation
High → Low	Error Operation

Note(1) Pin number starts from Right side

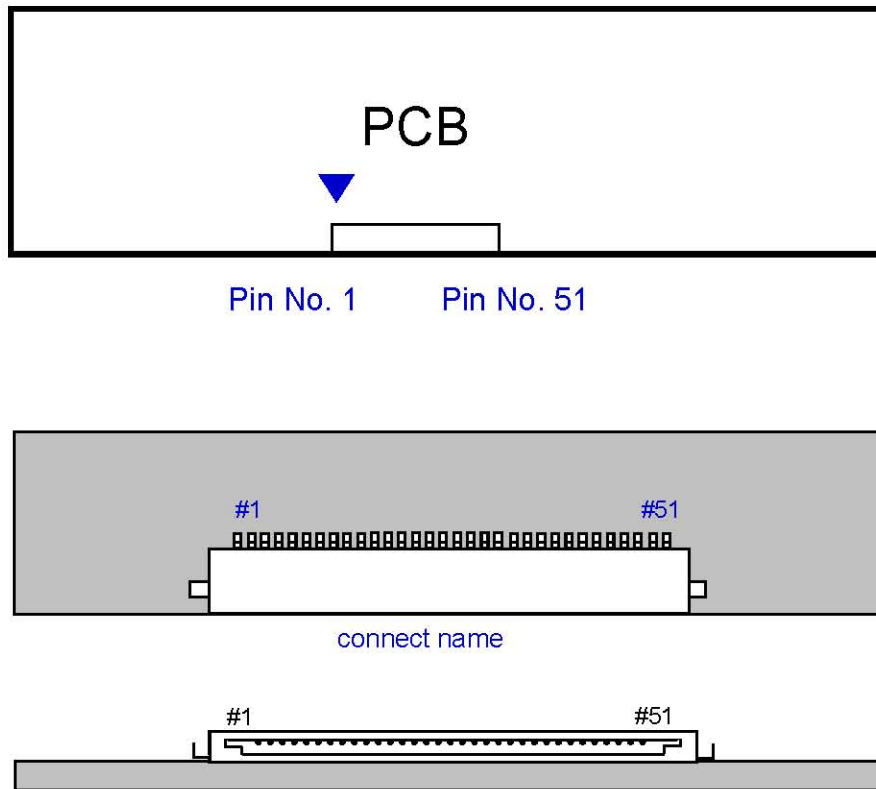

**Fig. Connector diagram**

- a. All GND pins should be connected together and also be connected to the LCD's metal chassis.
- b. All power input pins should be connected together.
- c. All NC pins should be separated from other signal or power.

## 5.2. Inverter Input Pin Configuration

Connector : 20022WR-14AML

Pin No.	Pin Configuration(FUNCTION)
1	24V
2	24V
3	24V
4	24V
5	24V
6	GND
7	GND
8	GND
9	GND
10	GND
11	Inverter Operation Status Output
12	Inverter On/Off Control Signal
13	No Connection
14	External Dimming Control Signal

### 5.3. Inverter Input Power Sequence & Specification

Items	Symbol	Conditions	Specifications			Unit	Note
			Min.	Typ.	Max.		
Input Voltage	$V_{in}$	-	21.6	24.0	26.4	V	$T_a=25\pm 3^{\circ}C$
Input Current	$I_{BAT}$	$V_{in}=24V$ EX_DIM=100%	-	3.25	3.80	A	-
Lamp Current	$I_o$	$V_{in}=24V$ EX_DIM=100%	13.0	14.0	15.0	mAms	-
Operating Frequency	$F_o$	$V_{in}=24V$ EX_DIM=100%	55.0	57.5	60.0	kHz	-
Backlight On/Off	ENA	ON	2.4	-	5.25	V	-
		OFF	-0.3	-	0.8		
Dimming Duty Output	$D_{max}$	$V_{in}=24V$ EX_DIM=100%	100	-	-	%	Note 1
	$D_{mh}$		15	20	25		-
	$D_{min}$		10	-	-		Note 2
Open Lamp Voltage	$V_{open}$	$V_{in}=24V$ EX_DIM=100%	1305	-	-	Vrms	Note 3
Striking Time	$T_{st}$	$V_{in}=24V$ EX_DIM=100%	1.0	1.5	2.0	sec	-
EX_DIM Frequency	$F_{EX\_DIM}$	$V_{in}=24.0V$	120	150	180	Hz	-
PWM Signal Amplitude	$V_{pwm}$	High (On)	2.4	-	5.25	V	-
		Low(Off)	-0.3	-	0.4		

\* All data was approved after running 120minutes with LCM .

Note1. Duty Measurement [Duty(%) =  $T_{on} / T \times 100$ ]

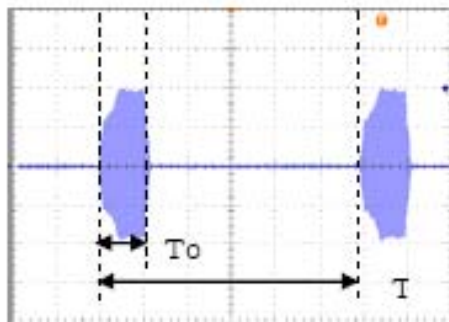

Note 2. There are not shut down and flicker at 10% @ 150Hz.

There is not shut down at 5% @ 75Hz.

Note 3. Measurement Method : Check Vs on BLU Remaining all Lamps.

## 5.4 LVDS Interface

	LVDS pin	Odd Data	Even Data
TxOUT/RxIN0	TxIN/RxOUT0	R2	R2
	TxIN/RxOUT1	R3	R3
	TxIN/RxOUT2	R4	R4
	TxIN/RxOUT3	R5	R5
	TxIN/RxOUT4	R6	R6
	TxIN/RxOUT6	R7	R7
	TxIN/RxOUT7	G2	G2
TxOUT/RxIN1	TxIN/RxOUT8	G3	G3
	TxIN/RxOUT9	G4	G4
	TxIN/RxOUT12	G5	G5
	TxIN/RxOUT13	G6	G6
	TxIN/RxOUT14	G7	G7
	TxIN/RxOUT15	B2	B2
	TxIN/RxOUT18	B3	B3
TxOUT/RxIN2	TxIN/RxOUT19	B4	B4
	TxIN/RxOUT20	B5	B5
	TxIN/RxOUT21	B6	B6
	TxIN/RxOUT22	B7	B7
	TxIN/RxOUT24	HSYNC	HSYNC
	TxIN/RxOUT25	VSYNC	VSYNC
	TxIN/RxOUT26	DEN	DEN
TxOUT/RxIN3	TxIN/RxOUT28	R0	R0
	TxIN/RxOUT29	R1	R1
	TxIN/RxOUT30	G0	G0
	TxIN/RxOUT31	G1	G1
	TxIN/RxOUT32	B0	B0
	TxIN/RxOUT33	B1	B1
	TxIN/RxOUT34	Reserved	Reserved



### 5.5 Input Signals, Basic Display Colors and Gray Scale of Each Color

COLOR	DISPLAY (8bit)	DATA SIGNAL																					GRAY SCALE LEVEL			
		RED							GREEN							BLUE										
		R0	R1	R2	R3	R4	R5	R6	R7	G0	G1	G2	G3	G4	G5	G6	G7	B0	B1	B2	B3	B4		B5	B6	B7
BASIC COLOR	BLACK	0	0	0	0	0	0	0	0	0	0	0	0	0	0	0	0	0	0	0	0	0	0	0	-	
	BLUE	0	0	0	0	0	0	0	0	0	0	0	0	0	0	0	0	1	1	1	1	1	1	1	1	-
	GREEN	0	0	0	0	0	0	0	0	1	1	1	1	1	1	1	1	0	0	0	0	0	0	0	0	-
	CYAN	0	0	0	0	0	0	0	0	1	1	1	1	1	1	1	1	1	1	1	1	1	1	1	1	-
	RED	1	1	1	1	1	1	1	1	0	0	0	0	0	0	0	0	0	0	0	0	0	0	0	0	-
	MAGENTA	1	1	1	1	1	1	1	1	0	0	0	0	0	0	0	0	1	1	1	1	1	1	1	1	-
	YELLOW	1	1	1	1	1	1	1	1	1	1	1	1	1	1	1	1	0	0	0	0	0	0	0	0	-
	WHITE	1	1	1	1	1	1	1	1	1	1	1	1	1	1	1	1	1	1	1	1	1	1	1	1	-
GRAY SCALE OF RED	BLACK	0	0	0	0	0	0	0	0	0	0	0	0	0	0	0	0	0	0	0	0	0	0	0	R0	
	DARK ↑	0	0	0	0	0	0	0	0	0	0	0	0	0	0	0	0	0	0	0	0	0	0	0	R1	
		0	1	0	0	0	0	0	0	0	0	0	0	0	0	0	0	0	0	0	0	0	0	0	R2	
		:	:	:	:	:	:	:	:	:	:	:	:	:	:	:	:	:	:	:	:	:	:	:	R3~R252	
		:	:	:	:	:	:	:	:	:	:	:	:	:	:	:	:	:	:	:	:	:	:	:	R253	
	LIGHT ↓	1	0	1	1	1	1	1	1	0	0	0	0	0	0	0	0	0	0	0	0	0	0	0	R254	
		0	1	1	1	1	1	1	1	0	0	0	0	0	0	0	0	0	0	0	0	0	0	0	R255	
RED	1	1	1	1	1	1	1	1	0	0	0	0	0	0	0	0	0	0	0	0	0	0	0	R255		
GRAY SCALE OF GREEN	BLACK	0	0	0	0	0	0	0	0	0	0	0	0	0	0	0	0	0	0	0	0	0	0	0	G0	
	DARK ↑	0	0	0	0	0	0	0	0	1	0	0	0	0	0	0	0	0	0	0	0	0	0	0	G1	
		0	0	0	0	0	0	0	0	0	1	0	0	0	0	0	0	0	0	0	0	0	0	0	G2	
		:	:	:	:	:	:	:	:	:	:	:	:	:	:	:	:	:	:	:	:	:	:	:	G3~G252	
		:	:	:	:	:	:	:	:	:	:	:	:	:	:	:	:	:	:	:	:	:	:	:	G253	
	LIGHT ↓	0	0	0	0	0	0	0	0	0	1	0	1	1	1	1	1	0	0	0	0	0	0	0	G254	
		0	0	0	0	0	0	0	0	0	1	1	1	1	1	1	1	0	0	0	0	0	0	0	G255	
GREEN	0	0	0	0	0	0	0	0	1	1	1	1	1	1	1	1	0	0	0	0	0	0	0	G255		
GRAY SCALE OF BLUE	BLACK	0	0	0	0	0	0	0	0	0	0	0	0	0	0	0	0	0	0	0	0	0	0	0	B0	
	DARK ↑	0	0	0	0	0	0	0	0	0	0	0	0	0	0	0	0	1	0	0	0	0	0	0	B1	
		0	0	0	0	0	0	0	0	0	0	0	0	0	0	0	0	0	1	0	0	0	0	0	B2	
		:	:	:	:	:	:	:	:	:	:	:	:	:	:	:	:	:	:	:	:	:	:	:	B3~B252	
		:	:	:	:	:	:	:	:	:	:	:	:	:	:	:	:	:	:	:	:	:	:	:	B253	
	LIGHT ↓	0	0	0	0	0	0	0	0	0	0	0	0	0	0	0	0	0	1	0	1	1	1	1	B254	
		0	0	0	0	0	0	0	0	0	0	0	0	0	0	0	0	0	1	1	1	1	1	1	B255	
BLUE	0	0	0	0	0	0	0	0	0	0	0	0	0	0	0	0	1	1	1	1	1	1	1	B255		

Note) Definition of Gray :

Rn : Red Gray, Gn : Green Gray, Bn : Blue Gray (n = Gray level)

Input Signal : 0 = Low level voltage, 1 = High level voltage

## 6. EDID Information

### 6.1 EEPROM Data

EEPROM Data					
No	Item	Spec	Address	Data	Remark
1	Panel Product Vender	XXXX	00	XX	SONY Choice - Note 1
2	Screen Size	XX	01	XX	16進
3	H-Resolution	XXXX	02,03	XX,XX	16進
4	V-Resolution	XXX	04,05	XX,XX	16進
5	Vertical Frequency	XX	06	XX	- Note 2
6	Data Format	XX	07	XX	- Note 3
7	FRC Revision Information	X	ED	XX	ASCII - Note 4
8	Part Number	XXX(X)XXXXXX XX	E0~EC	XX,XX,XX,XX,XX, XX, XX,XX,XX,XX,XX, XX ,XX,XX,XX,XX	ASCII - Note 5, 6

※ Note 1.

Data	Panel Vender Code
00	HDLCD(SEC)
01	Others
02	Others
03	Others
04	Others
05	Others

※ Note 2.

Data	V-Frequency
00	50/60Hz
01	100/120HZ
02	200/240Hz

※ Note 3.

Data	Data Format
00	6Bit
01	8Bit
02	10Bit

※ Note 4.

- FRC Revision Code will be Changed from "00" to "41" (A)  
When FRC IC is changed. At First MP. This Code will be "00"

※ Note 5.

- LTY[Z]XXXXXXXX Only for SEC Model

※ Note 6.

- Rest of them must be "00" (Null)

## 6.2 EEPROM Data Map

	0	1	2	3	4	5	6	7	8	9	A	B	C	D	E	F
0	XX	XX	XX	XX	XX	XX	XX	XX	00	00	00	00	00	00	00	00
1	00	00	00	00	00	00	00	00	00	00	00	00	00	00	00	00
2	00	00	00	00	00	00	00	00	00	00	00	00	00	00	00	00
3	00	00	00	00	00	00	00	00	00	00	00	00	00	00	00	00
4	00	00	00	00	00	00	00	00	00	00	00	00	00	00	00	00
5	00	00	00	00	00	00	00	00	00	00	00	00	00	00	00	00
6	00	00	00	00	00	00	00	00	00	00	00	00	00	00	00	00
7	00	00	00	00	00	00	00	00	00	00	00	00	00	00	00	00
8	00	00	00	00	00	00	00	00	00	00	00	00	00	00	00	00
9	00	00	00	00	00	00	00	00	00	00	00	00	00	00	00	00
A	00	00	00	00	00	00	00	00	00	00	00	00	00	00	00	00
B	00	00	00	00	00	00	00	00	00	00	00	00	00	00	00	00
C	00	00	00	00	00	00	00	00	00	00	00	00	00	00	00	00
D	00	00	00	00	00	00	00	00	00	00	00	00	00	00	00	00
E	XX	XX	XX	XX	XX	XX	XX	XX	XX	XX	XX	XX	XX	XX	00	00
F	00	00	00	00	00	00	00	00	00	00	00	00	00	00	00	00

## 7. Interface Timing

### 7.1 Timing Parameters ( DE only mode )

SIGNAL	ITEM	SYMBOL	MIN.	TYP.	MAX.	Unit	NOTE
Clock	Frequency	$1/T_C$	130	148.5	155	MHz	-
Hsync		$F_H$	50	67.5	73	KHz	-
Vsync		$F_V$	47	60	62	Hz	-
Vertical Display Term	Active Display Period	$T_{VD}$	-	1080	-	lines	-
	Vertical Total	$T_{VB}$	1100	1125	1480	Lines	-
Horizontal Display Term	Active Display Period	$T_{HD}$	-	1920	-	clocks	-
	Horizontal Total	$T_H$	2154	2200	2450	clocks	-

Note) This product is DE only mode. The input of Hsync & Vsync signal does not have an effect on normal operation.

- (1) Test Point : TTL control signal and CLK at LVDS Tx input terminal in system
- (2) Internal  $V_{DD} = 3.3V$

## 7.2 Timing diagrams of interface signal ( DE only mode )

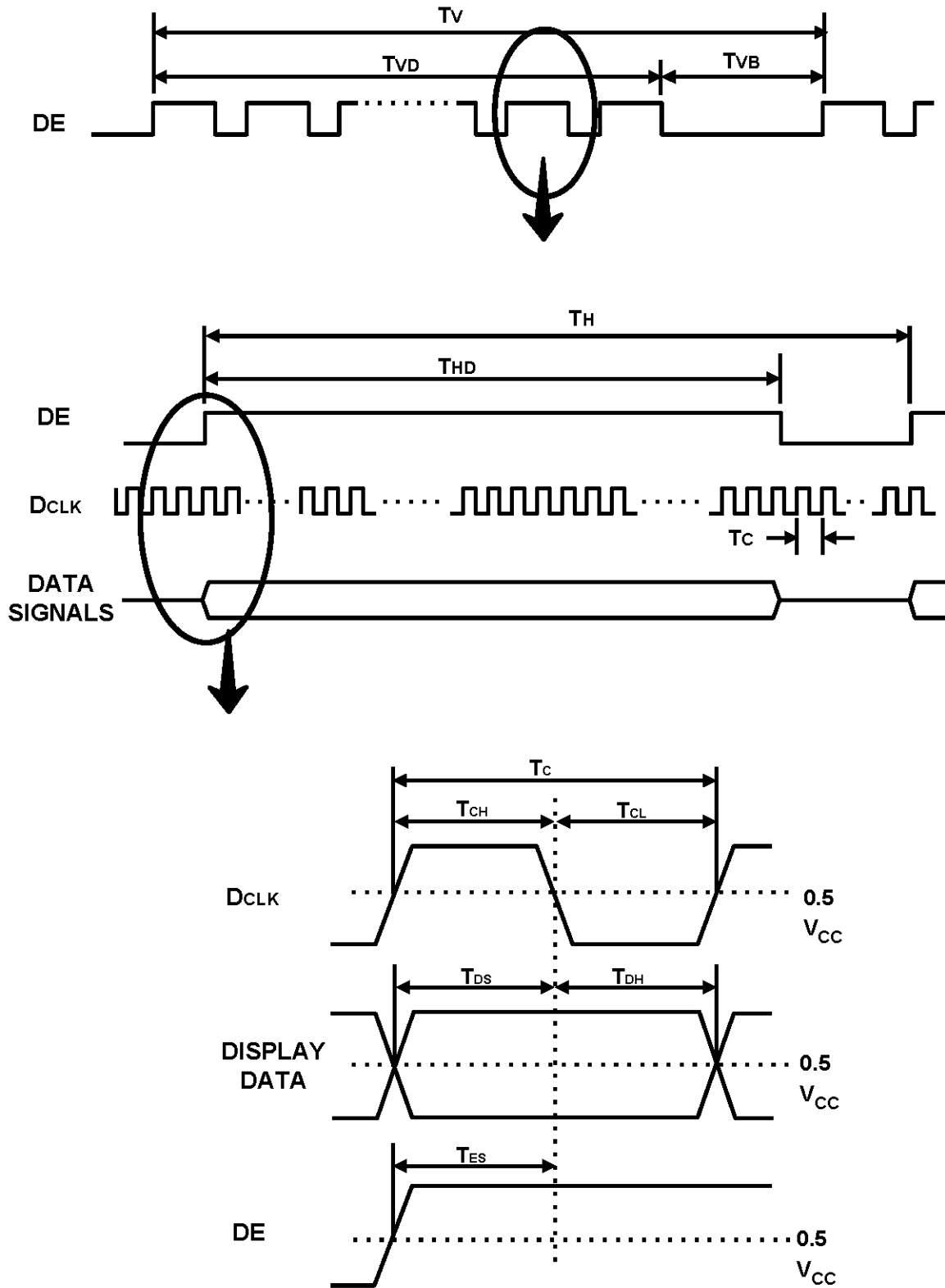

### 7.3 Power ON/OFF Sequence

To prevent a latch-up or DC operation of the LCD Module, the power on/off sequence should be as the diagram below.

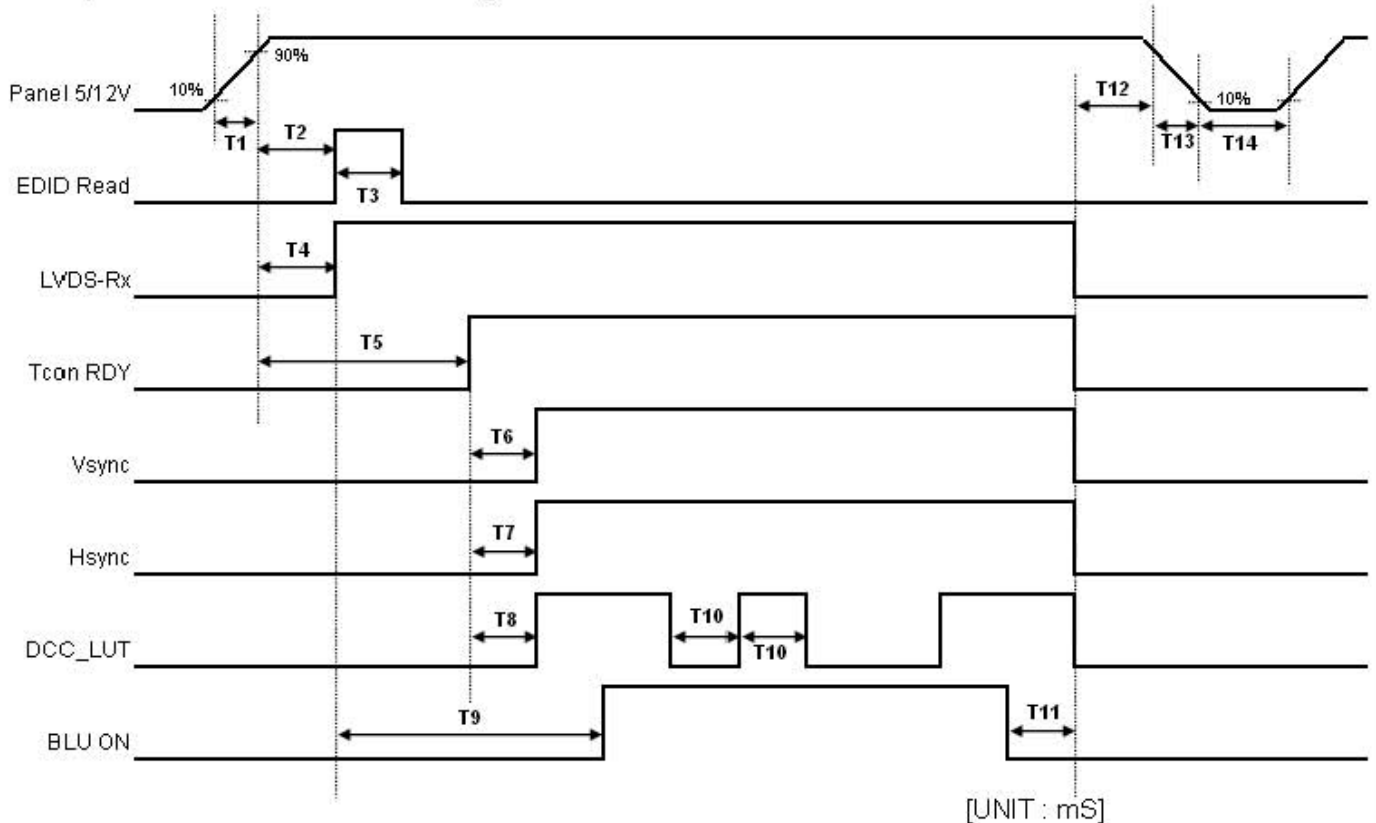

	Min	Max		Min	Max
T1	0.47	30	T8	30	-
T2	0	100	T9	500	-
T3	0	100	T10	50	-
T4	0.1	50	T11	100	-
T5	220	350	T12	0	50
T6	0	30	T13	0	300
T7	0	30	T14	1000	-

- The supply voltage of the external system for the Module input should be the same as the definition of  $V_{DD}$ .
- Apply the lamp voltage within the LCD operation range. When the back light turns on before the LCD operation or the LCD turns off before the back light turns off, the display may momentarily show abnormal screen.
- In case of  $V_{DD}$  = off level, please keep the level of input signals low or keep a high impedance.
- T14 should be measured after the Module has been fully discharged between power off and on period.
- Interface signal should not be kept at high impedance when the power is on.

## 8. Outline dimension (Front view)

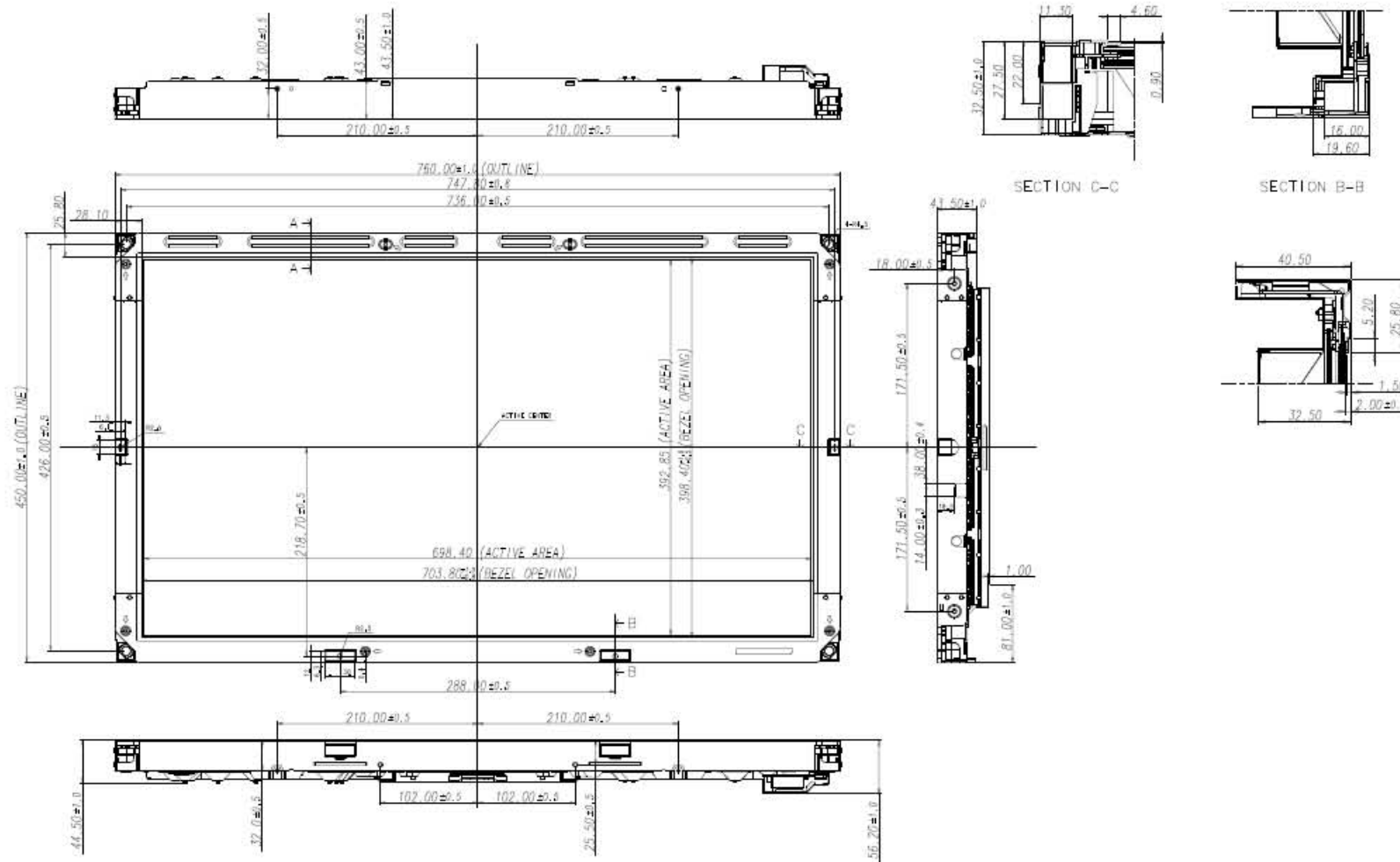





## 9. EMI Specification

: -3dB at CISPR22 Class B

This EMI Recommendation is recommended to be measured as SET Condition.

## 10. UL Approval

## 11. Reliability Test

Item	Test condition	Quantity
Temperature Step Stress	0 ~ 50 °C, 10Cycle determination	4EA
HTOL	50 °C, 1000hr (500hr determination)	8EA
LTOL	0 °C, 1000hr (500hr determination)	4EA
RTOL	20 °C, continue ~	4EA
HTS	70 °C, 1000hr (500hr determination)	4EA
LTS	-30 °C, 1000hr (500hr determination)	4EA
THB	40 °C / 95%RH, 1000hr (500hr determination)	4EA
WHTS	60 °C / 75%RH, 1000hr (500hr determination)	4EA
T/C	-20 °C ~ 60 °C, 200cycle (100cycle determination)	4EA
ESD (non-operation)	± 10 kV, 200pF/100 Ω, 9Point, 3times/Point	3EA
ESD(operation)	contact : ± 8 kV, 150pF/330Ω, 210Point, 1 time/Point non-contact : ± 15 kV, 150pF/330Ω, 100Point, 1 time/Point	3EA
Input Con. ESD	contact : ± 2kV, 200pF/100, Input Con. Pin, 3 times/Pin	3EA
POWER ON/OFF	30sec (on) / 30sec(off) : 12,000 times	4EA
Vibration	10~300Hz/1.5G/10minSR, XYZ, 30min/axis	3EA
Shock	Condition : 11msec, ±XY Z 1time/axis 50G	3EA
PALLET Vibration	1.146 Grms, 2~200Hz, Random, Z axis 1Hr	1PALLET(13EA)
PALLET Drop	20cm, Bottom, Front, Rear 1times	1PALLET(13EA)

### [ Result Evaluation Criteria]

Under the display quality test conditions with normal operation state, these shall be no change which may affect practical display function.

HTOL/ LTOL : High/Low Temperature Operating Life,  
 THB : Temperature Humidity Bias  
 HTS/LTS : High/Low Temperature Storage  
 WHTS : Wet High Temperature Storage

## 12. PACKING

### ※ Applied to SESL Model

#### 12.1 CARTON (Internal Package)

##### (1) Packing Form

Corrugated fiberboard box and corrugated cardboard as shock absorber

##### (2) Packing Method

Packing Box

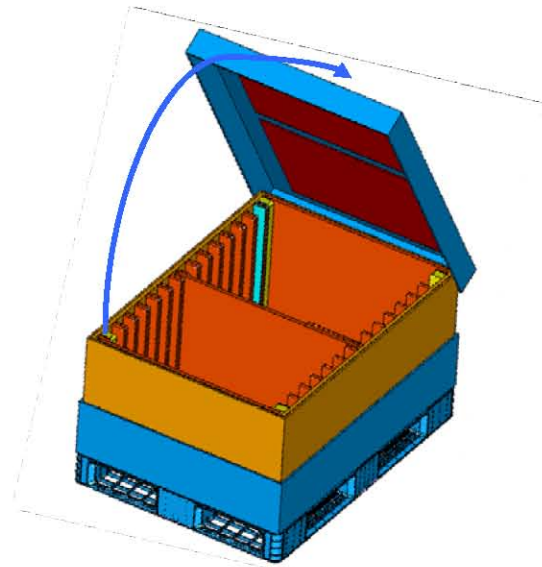
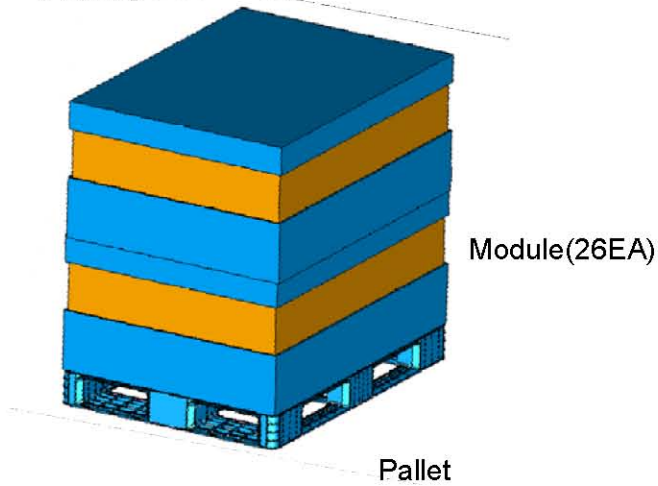

→ Direction be able to Open

#### 12.2 Packing Specification

Item	Specification	Remark
LCD Packing	26 ea / (Packing Box)	1. 156Kg/LCD(26ea) 2. 30kg/Packing Box(2set) 3. Packing Box Material : DW, SW
Desiccant (Drier)	2ea/LCD	10g/ea, Cobalt-dichloride-free
Pallet	1 Box / Pallet	Pallet weight : 8kg
Packing Direction	Vertical	-
Total Pallet Size	H x V x height	1150mm x 850mm x 1125mm
Total Pallet Weight	194.52kg	Pallet(8kg) + Module( 26 x 6 = 156kg) + Packing BOX(15 x 2 = 30kg) + Desiccant(0.02kg x 26 = 0.52kg)

※ Applied to SELSK Model

12.3 CARTON (Internal Package)

(1) Packing Form

Corrugated fiberboard box and corrugated cardboard as shock absorber

(2) Packing Method

Packing Pallet Box

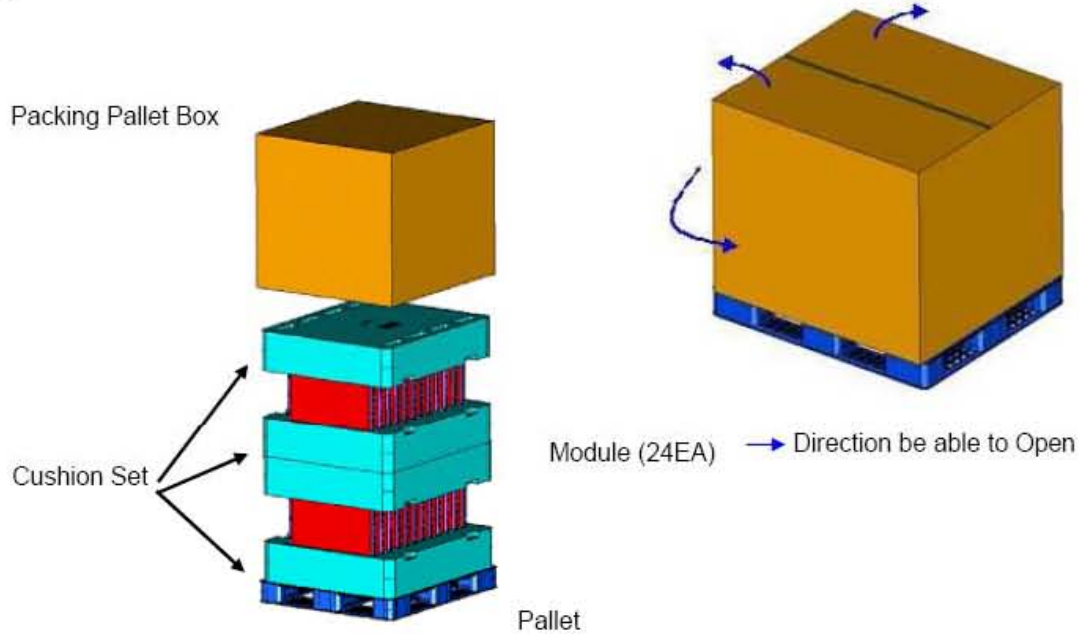

12.4 Packing Specification

Item	Specification	Remark
LCD Packing	24 ea / (Packing-Pallet Box)	1. 144Kg/LCD(24ea) 2. 14kg/Cushion Set(4ea) 3. 6.7kg/Packing-Pallet Box(1ea) 4. Cushion Material : EPS 5. Packing Pallet Box Material : DW4
Desiccant (Drier)	2ea/LCD	10g/ea, Cobalt-dichloride-free
Pallet	1 Box / Pallet	Pallet weight : 8kg
Packing Direction	Vertical	-
Total Pallet Size	H x V x height	1150mm x 985mm x 1159mm
Total Pallet Weight	173.18kg	Pallet(8kg) + Module( 24 x 6 = 144kg) + Cushion(14kg) + Pallet-BOX(6.7kg) + Desiccant(0.02kg x 24 = 0.48kg)

### 13. MARKING & OTHERS

A nameplate bearing followed by is affixed to a shipped product at the specified location on each product.

- (1) Parts number : LTY[Z]320HM03-XXX
- (2) Revision: One letters
- (3) Lot number : X X X X XXX XX X

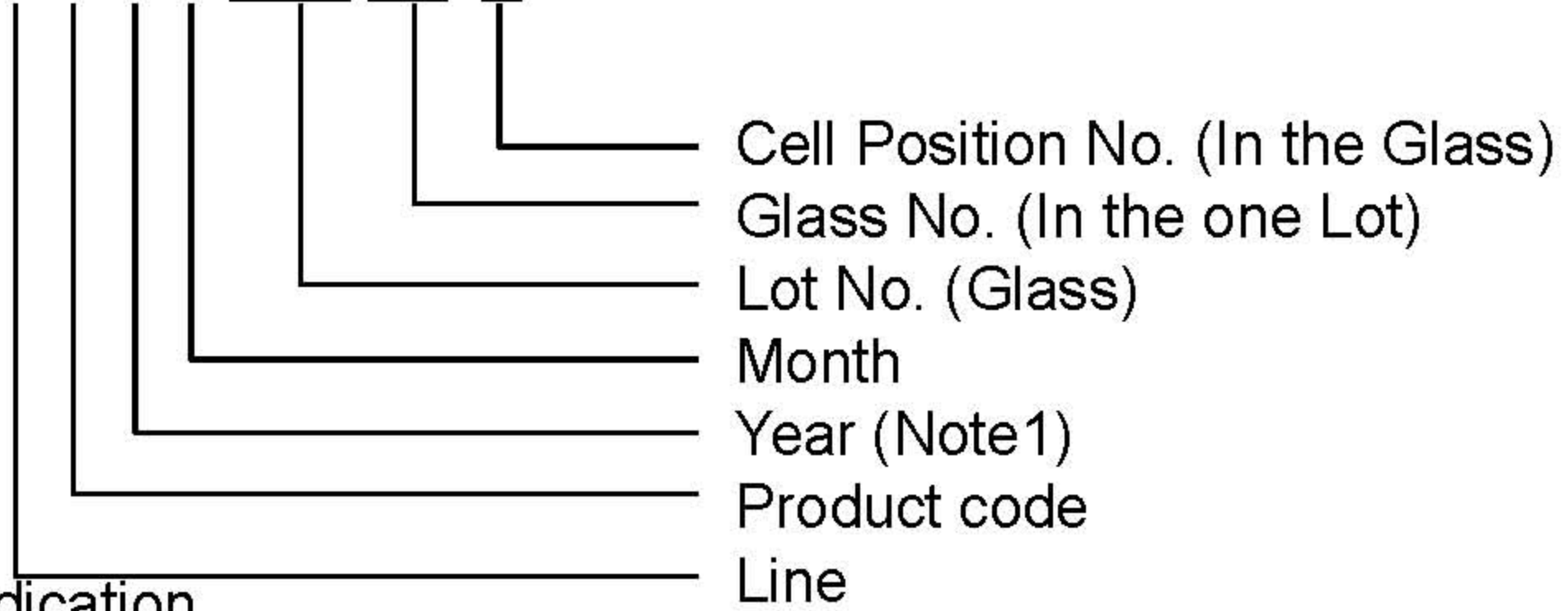

(4) Nameplate Indication

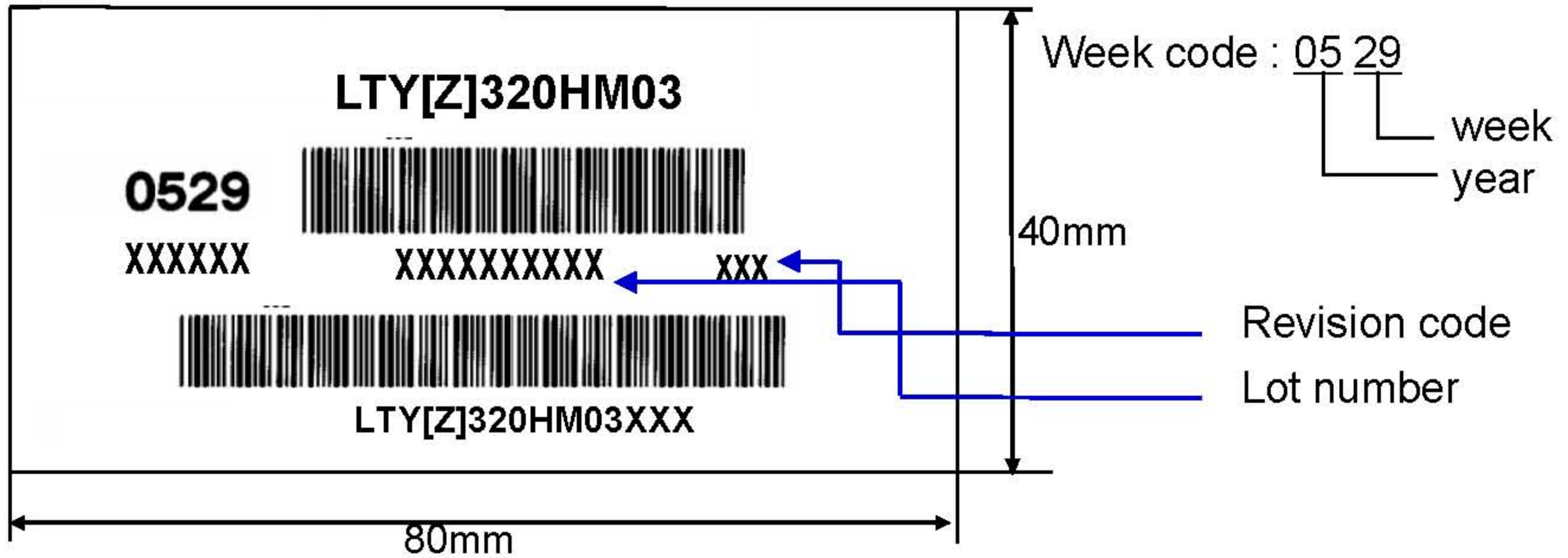

(5) Packing box attach

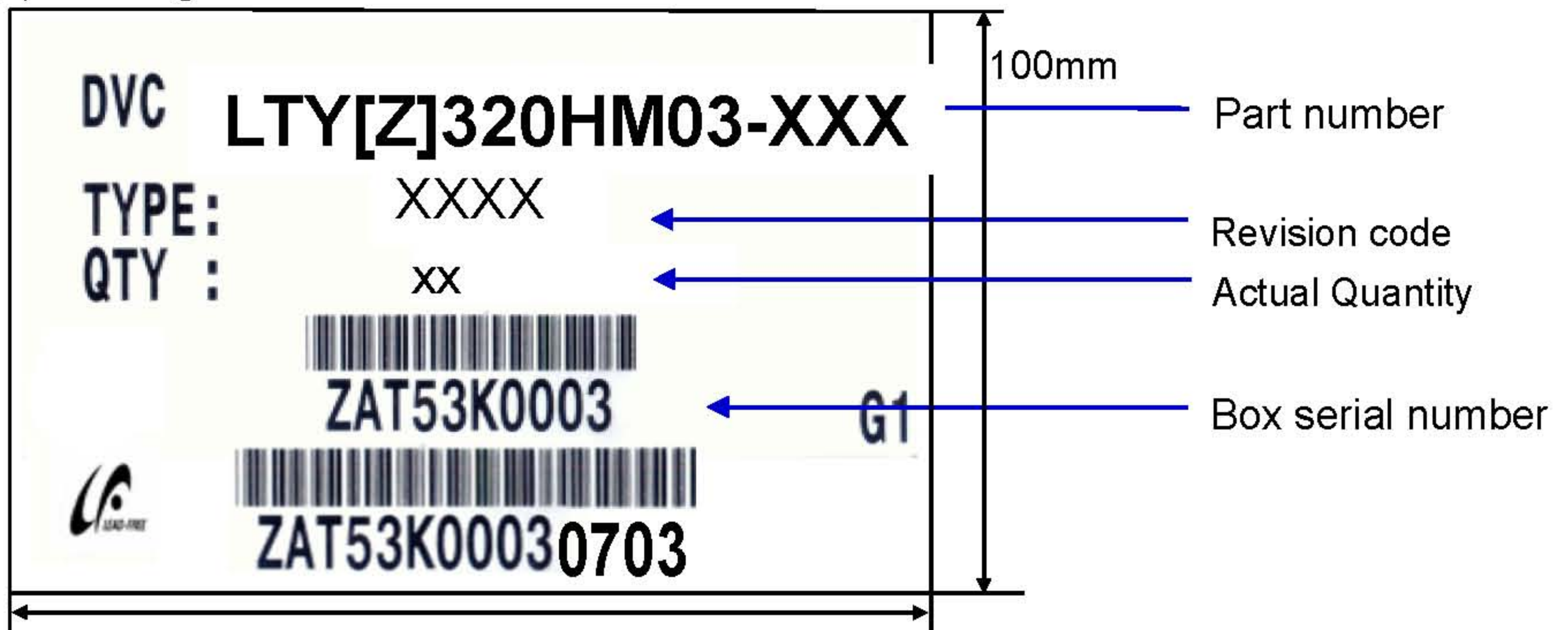

(6) Others

- 1. After service part  
Lamps cannot be replaced because of the narrow bezel structure.

MODEL	LTY[Z]320HM03	Doc. No	05-001-S-100917	Page	30 / 33
-------	---------------	---------	-----------------	------	---------

## 14. General Precautions

### 14.1 Handling

- (a) When the Module is assembled, it should be attached to the system firmly using all mounting holes. Be careful not to twist and bend the Module.
- (b) Because the inverter use high voltage, it should be disconnected from power before it is assembled or disassembled.
- (c) Refrain from strong mechanical shock and / or any force to the Module.  
In addition to damage, this may cause improper operation or damage to the Module and CCFT back light.
- (d) Note that polarizers are very fragile and could be damage easily.  
Do not press or scratch the surface harder than a HB pencil lead.
- (e) Wipe off water droplets or oil immediately. If you leave the droplets for a long time, staining or discoloration may occur.
- (f) If the surface of the polarizer is dirty, clean it using absorbent cotton or soft cloth.
- (g) Desirable cleaners are water, IPA(Isopropyl Alcohol) or Hexane.  
Do not use Ketone type materials(ex. Acetone), Ethyl alcohol, Toluene, Ethyl acid or Methyl chloride. It might permanent damage to the polarizer due to chemical reaction.
- (h) If the liquid crystal material leaks from the panel, it should be kept away from the eyes or mouth . In case of contact with hands, legs or clothes, it must be washed away with soap thoroughly.
- (i) Protect the Module from static, or the CMOS Gate Array IC would be damaged.
- (j) Use finger-stalls with soft gloves in order to keep display clean during the incoming inspection and assembly process.
- (k) Do not disassemble the Module.
- (l) Do not pull or fold the lamp wire.
- (m) Do not adjust the variable resistor located on the Module.
- (n) Protection film for polarizer on the Module should be slowly peeled off just before use so that the electrostatic charge can be minimized.
- (o) Pins of I/F connector should not be touched directly with bare hands.

## 14.2 Storage

- (a) Do not leave the Module in high temperature, and high humidity for a long time. It is highly recommended to store the Module with temperature from 0 to 35°C and relative humidity of less than 70%.
- (b) Do not store the TFT-LCD Module in direct sunlight.
- (c) The Module should be stored in a dark place. It is prohibited to apply sunlight or fluorescent light in storing.

## 14.3 Operation

- (a) No Connection or disconnect the Module in the "Power On" condition.
- (b) Power supply should always be turned on/off by the "Power on/off sequence"
- (c) Module has high frequency circuits. Sufficient suppression to the electromagnetic interference should be done by system manufacturers. Grounding and shielding methods may be important to minimize the interference.
- (d) The cable between the back light connector and its inverter power supply should be connected directly with a minimized length. A longer cable between the back light and the inverter may cause lower luminance of lamp(CCFT) and may require higher startup voltage(Vs).

## 14.4 Operation Condition Guide

- (a) The LCD product should be operated under normal conditions.  
Normal condition is defined as below;
  - Temperature :  $20 \pm 15^{\circ}\text{C}$
  - Humidity :  $55 \pm 20\%$
  - Display pattern : continually changing pattern (Not stationary)
- (b) If the product will be used in extreme conditions such as high temperature, humidity, display patterns or operation time etc., It is strongly recommended to contact SEC for Application engineering advice. Otherwise, its reliability and function may not be guaranteed. Extreme conditions are commonly found at Airports, Transit Stations, Banks, Stock market, and Controlling systems.

## 14.5 Others

- (a) Ultra-violet ray filter is necessary for outdoor operation.
- (b) Avoid condensation of water. It may result in improper operation or disconnection of electrode.
- (c) Do not exceed the absolute maximum rating value. ( supply voltage variation, input voltage variation, variation in part contents and environmental temperature, and so on)  
Otherwise the Module may be damaged.
- (d) If the Module keeps displaying the same pattern for a long period of time, the image may be "sticked" to the screen.  
To avoid image sticking, it is recommended to use a screen saver.
- (e) This Module has its circuitry PCB's on the rear side and should be handled carefully in order not to be stressed.
- (f) Please contact SEC in advance when you display the same pattern for a long time.