

Contents

Revision History	-----	(3)
General Description	-----	(4)
General Information	-----	(4)
1. Absolute Maximum Ratings	-----	(5)
2. Optical Characteristics	-----	(6)
3. Electrical Characteristics	-----	(9)
3.1 TFT LCD Module		
3.2 Back Light Unit		
4. Block Diagram	-----	(11)
5. Input Terminal Pin Assignment	-----	(12)
5.1 Input Signal & Power		
5.2 Balance Board		
5.3 LVDS Interface		
5.4 Input Signals, Basic Display Colors and Gray Scale of Each Color		
6. Interface Timing	-----	(20)
6.1 Timing Parameters (DE only mode)		
6.2 Timing Diagrams of interface Signal (DE only mode)		
6.3 Power ON/OFF Sequence		
7. Outline Dimension	-----	(23)
8. EMI Specification	-----	(25)
9. Input Spread Spectrum Specification		
10. UL Approval		
11. Reliability Test	-----	(26)
12. Packing	-----	(27)
13. Marking & Others	-----	(28)
14. General Precaution	-----	(29)
14.1 Handling		
14.2 Storage		
14.3 Operation		
14.4 Operation Condition Guide		
14.5 Others		

*** Revision History**

Date	Rev. No	Page	Summary
Jun 12, 2008	000	all	First issued
Oct 29, 2009	001	-	To apply improved D-IC Model Code Changed : LTY400HA10-001 → LTY400HA10-002

General Description

Description

LTY400HA10 is a color active matrix liquid crystal display (LCD) that uses amorphous silicon TFT (Thin Film Transistor) as switching components. This model is composed of a TFT LCD panel, a driver circuit and a back light unit. The resolution of a 40.0" is 1920 x 1080 and this model can display up to 1.07 billion colors with wide viewing angle of 89° or higher in all directions. This panel is intended to support applications to provide an excellent performance for Flat Panel Display such as Home-alone Multimedia TFT-LCD TV, Display terminals for AV application products, and High Definition TV (HDTV).

Features

- RoHS compliance (Pb-free)
- 1.07 billion (True-10Bit) Color Support
- High contrast ratio, high aperture ratio, fast response time
- SPVA (Super Patterned Vertical Align) mode
- Wide viewing angle ($\pm 89^\circ$)
- Full HD (1920 x 1080 pixels) resolution (16:9)
- Low Power consumption
- 16 High color gamut CCFTs (Cold Cathode Fluorescent Tube)
- DE (Data Enable) mode
- LVDS (Low Voltage Differential Signaling) Interface

General Information

Items	Specification	Unit	Note
Module Size	952.0(H _{TYP}) x 551.0(V _{TYP})	mm	± 1.0 mm
	54.2(D _{MAX})		
Weight	11000(Max)	g	
Pixel Pitch	0.46125(H) x 0.15375(W)*3	Mm	
Active Display Area	885.6(H) x 498.15(V)	Mm	
Surface Treatment	Haze 14%, Hard-Coating(3H)		
Display Colors	1.07 Billion (True-10Bit)	colors	
Number of Pixels	1920 x 1080	pixel	
Pixel Arrangement	RGB vertical stripe		
Display Mode	Normally Black		
Luminance of White	500	cd/m ²	Typ.

1. Absolute Maximum Ratings

If the condition exceeds maximum ratings, it can cause malfunction or unrecoverable damage to the device.

Item	Symbol	Min.	Max.	Unit	Note
Power Supply Voltage	V_{DD}	GND-0.5	13	V	(1)
Storage temperature	T_{STG}	-20	65	°C	(2)
Operating Temperature	T_{OPR}	0	50	°C	
Panel surface temperature	T_{SUR}	0	65	°C	(3)
Shock (non - operating)	S_{NOP}	-	50	G	(4)
Vibration (non - operating)	V_{NOP}	-	1.5	G	(5)

Note (1) $T_a = 25 \pm 2 \text{ }^\circ\text{C}$

(2) Temperature and relative humidity range are shown in the figure below.

a. 90 % RH Max. ($T_a \leq 40 \text{ }^\circ\text{C}$)

b. Maximum wet-bulb temperature at $40 \text{ }^\circ\text{C}$ or less. ($T_a \leq 40 \text{ }^\circ\text{C}$)

c. No condensation

(3) Polarizer will not be damaged in this range, even though abnormal visual problems occur in T_{SUR} range.

(4) 11ms, sine wave, one time for $\pm X, \pm Y, \pm Z$ axis

(5) 10-300 Hz, Sweep rate 10min, 30min for X,Y,Z axis

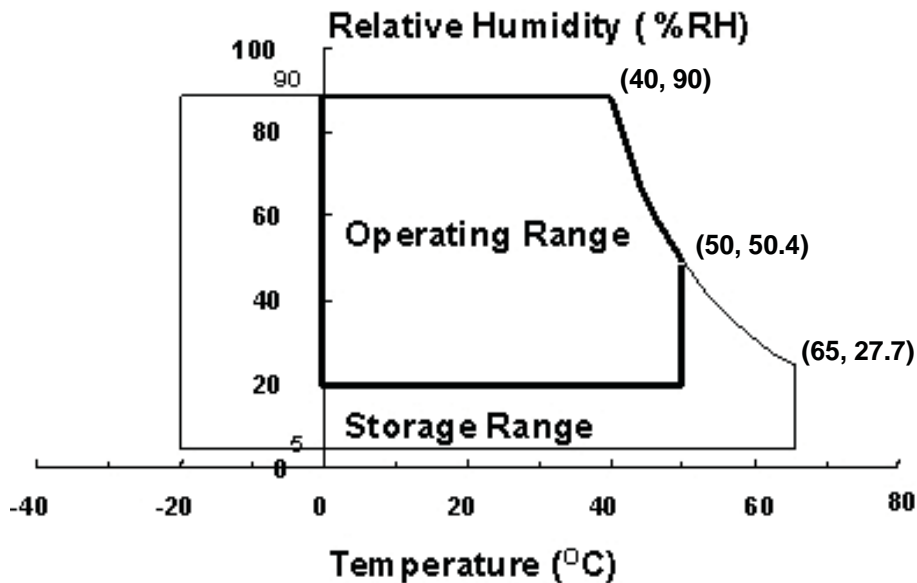

Fig. Temperature and Relative humidity range

2. Optical Characteristics

The optical characteristics should be measured in a dark room or equivalent.

Measuring equipment : TOPCON BM-7,SPECTRORADIOMETER SR-3

(Ta = 25 ± 2°C, VDD=12V, fv= 60Hz, f_{DCLK}=148.5MHz, Dim = 100%)

Item	Symbol	Condition	Min.	Typ.	Max.	Unit	Note	
Contrast Ratio (Center of screen)	C/R	Normal $\theta_L, R=0$ $\theta_U, D=0$ Viewing Angle	*2000	3000	-		(3) SR-3	
Response Time	Rising		Tr	-	10	16	Msec	(5) BM-7
	Falling		Tf	-	6	10		
	G-to-G		Tg	-	8	-		
Luminance of White (Center of screen)	Y _L			430	500	-	cd/m ²	(6) SR-3
Color Chromaticity (CIE 1931)	Red		Rx	TYP. -0.03	0.652	TYP. +0.03		(7),(8) SR-3
			Ry		0.330			
	Green		Gx		0.220			
			Gy		0.665			
	Blue		Bx		0.150			
		By	0.062					
	White	Wx	0.275					
		Wy	0.285					
Color Gamut	-		-	90	-	%	(7) SR-3	
Gamma	γ		-	2.2	-			
Color Temperature	-		-	10000	-	K	(7) SR-3	
Viewing Angle	Hor.	θ _L	C/R ≥ 10	79	89	-	Degree	(8) SR-3
		θ _R		79	89	-		
	Ver.	θ _U		79	89	-		
		θ _D		79	89	-		
Brightness Uniformity (9 Points)	B _{uni}		-	-	30	%	(4) SR-3	

*marked Item's Value does not follow Specification above when "white stain" occurs at Center Point [Point ⑤ of Note 2.]

Note (1) Test Equipment Setup

The measurement should be executed in a stable, windless and dark room between 40min and 60min after lighting the back light at the given temperature for stabilization of the back light. This should be measured in the center of screen.

Single lamp current @ Dim = 100%

Environment condition : Ta = 25 ± 2 °C

MODEL	LTY400HA10	Doc. No	05-001-S-091029	Page	6 / 31
-------	------------	---------	-----------------	------	--------

Photo detector	Field
SR-3	1°
BM-7	2°

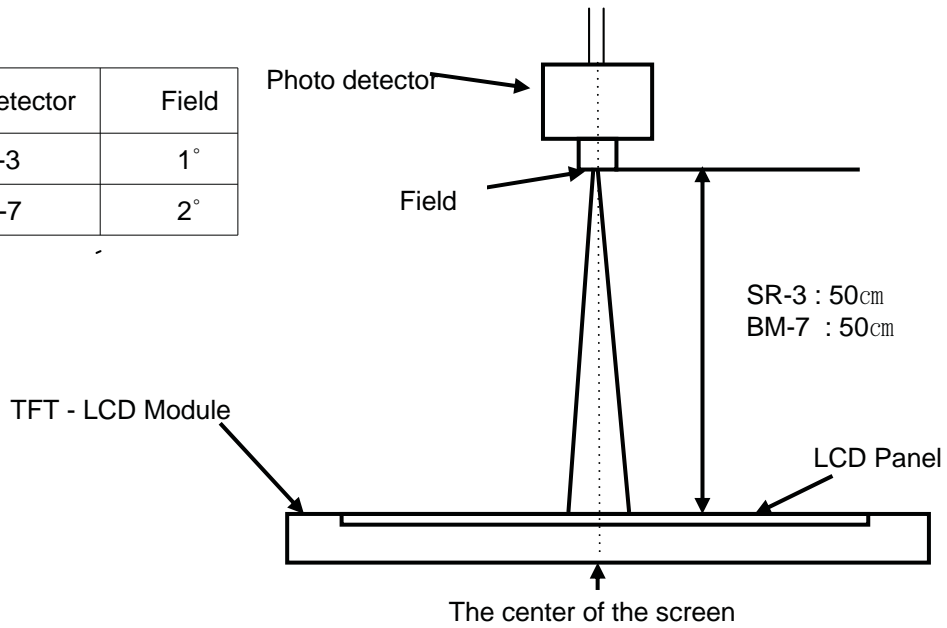

Note (2) Definition of test point

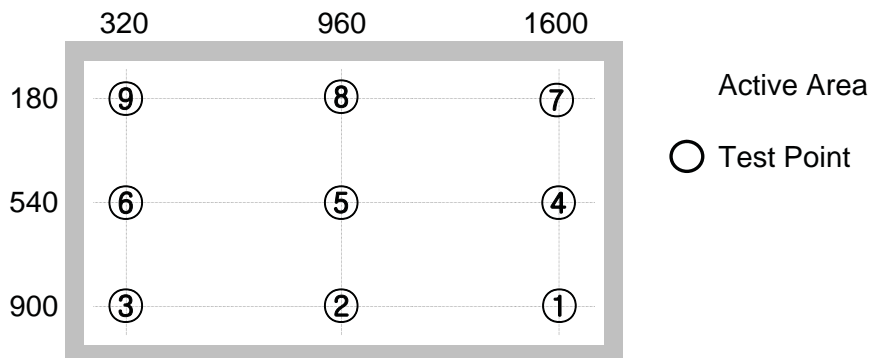

Note (3) Definition of Contrast Ratio (C/R)

: Ratio of gray max (Gmax) & gray min (Gmin) at the center point ⑤ of the panel

$$C/R = \frac{G \max}{G \min}$$

Gmax : Luminance with all pixels white

Gmin : Luminance with all pixels black

Note (4) Definition of 9 points brightness uniformity

$$B_{uni} = 100 * \frac{(B_{max} - B_{min})}{B_{max}}$$

Bmax : Maximum brightness

Bmin : Minimum brightness

Note (5) Definition of Response time : Sum of Tr, Tf

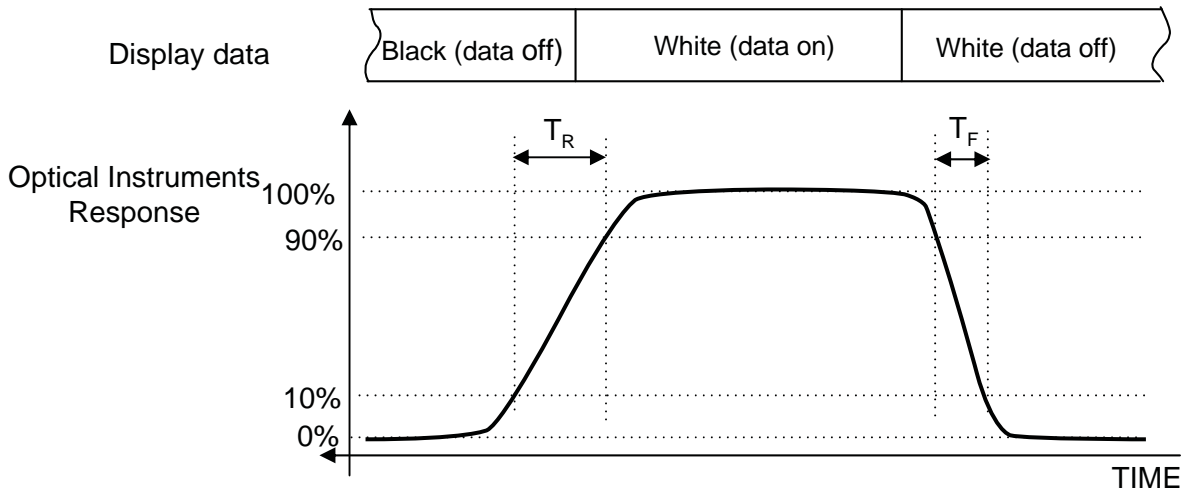

Note (6) Definition of Luminance of White : Luminance of white at center point ⑤

Note (7) Definition of Color Chromaticity (CIE 1931)

Color coordinate of Red, Green, Blue & White at center point ⑤

Note (8) Definition of Viewing Angle

: Viewing angle range ($C/R \geq 10$)

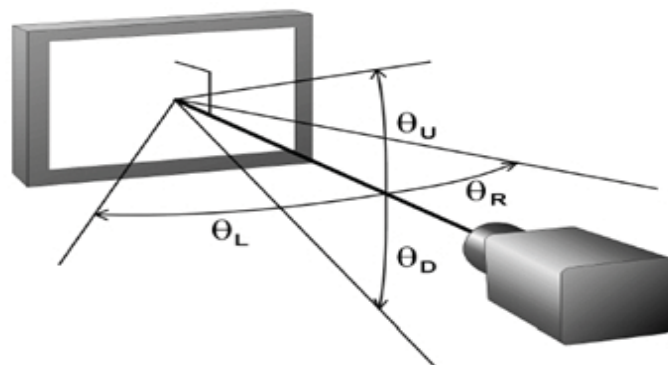

3. Electrical Characteristics

3.1 TFT LCD Module

The connector for display data & timing signal should be connected.

$T_a = 25^\circ\text{C} \pm 2^\circ\text{C}$

Item	Symbol	Min.	Typ.	Max.	Unit	Note
Voltage of Power Supply	V_{DD}	11	12	13	V	(1)
Current of Power Supply	(a) Black	-	600	-	mA	(2),(3)
	(b) White	-	1100	1200		
	(c) Mosaic	-	800	-		
	(d) Max Pattern	-	1320	1440		
Vsync Frequency	f_V	47	60	62	Hz	
Hsync Frequency	f_H	50	67.5	73	kHz	
Main Frequency	f_{DCLK}	130	148.5	155	MHz	
Rush Current	I_{RUSH}	-	-	5	A	(4)

Note (1) The ripple voltage should be controlled under 10% of V_{DD} .

(2) $f_V=60\text{Hz}$, $f_{DCLK} = 148.5\text{Hz}$, $V_{DD} = 12.0\text{V}$, DC Current.

(3) Power dissipation check pattern (LCD Module only)

a) Black Pattern

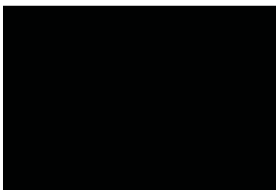

b) White Pattern



c) Mosaic

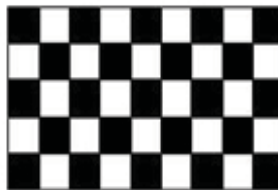

d)Max. Pattern

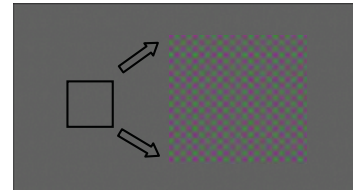

(4) Measurement Conditions

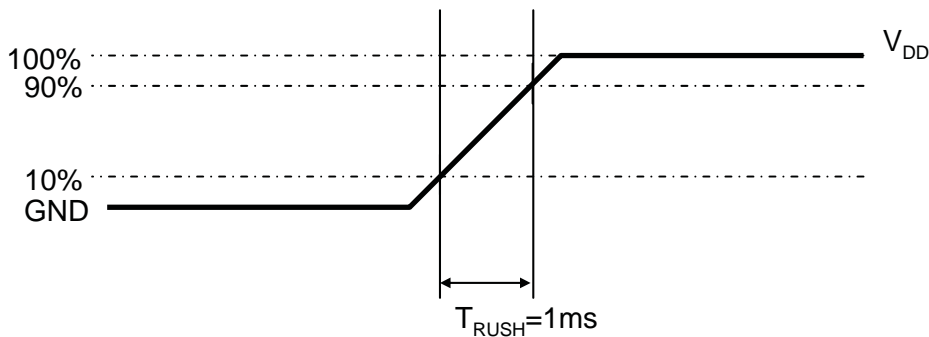

Rush Current I_{RUSH} can be measured when T_{RUSH} is 1ms.

3.2 Back Light Unit

The back light unit contains 20 CCFTs (Cold Cathode Fluorescent Tube).
The Characteristics of lamps are shown in the following tables.

Ta=25 ± 2°C

Item	Symbol	Min.	Typ.	Max.	Unit	Note
Operating Life Time	Hr	30,000	-	-	Hour	(1)
Lamp Current	I _L	6	-	12	mA	Single

Note (1) It is defined as the time to take until the brightness reduces to 50% of its original value.

[Operating condition : Ta = 25±2°C, I_L = 8mA(typ.), For single lamp only.]

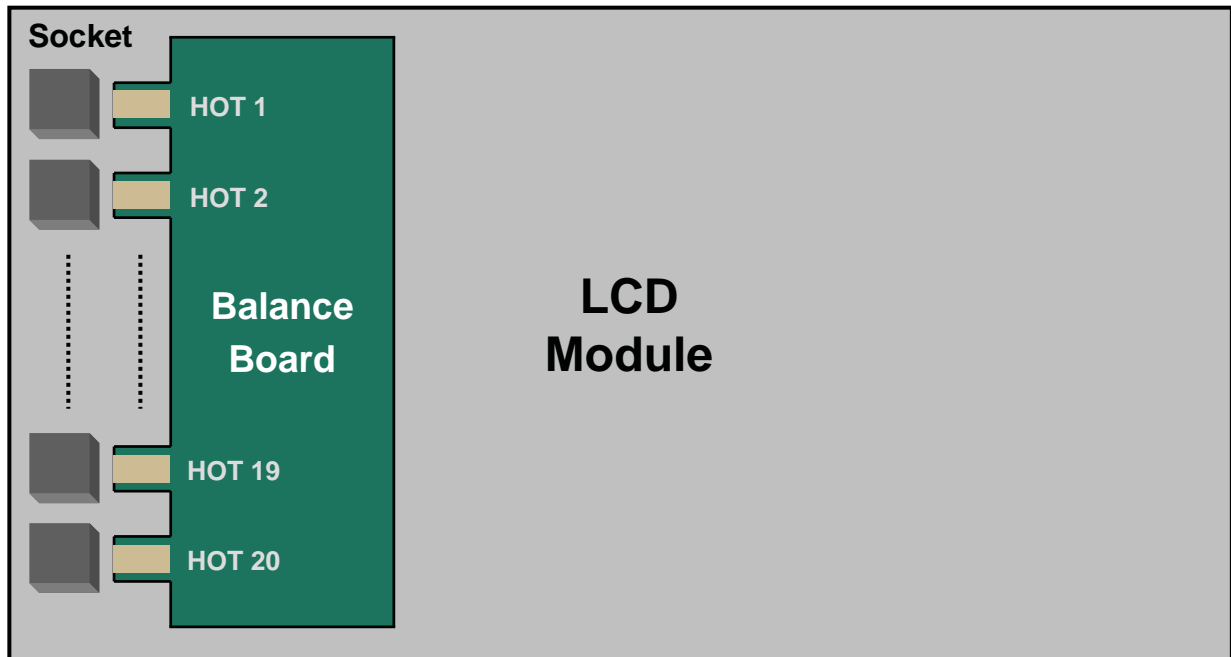

4. Block Diagram

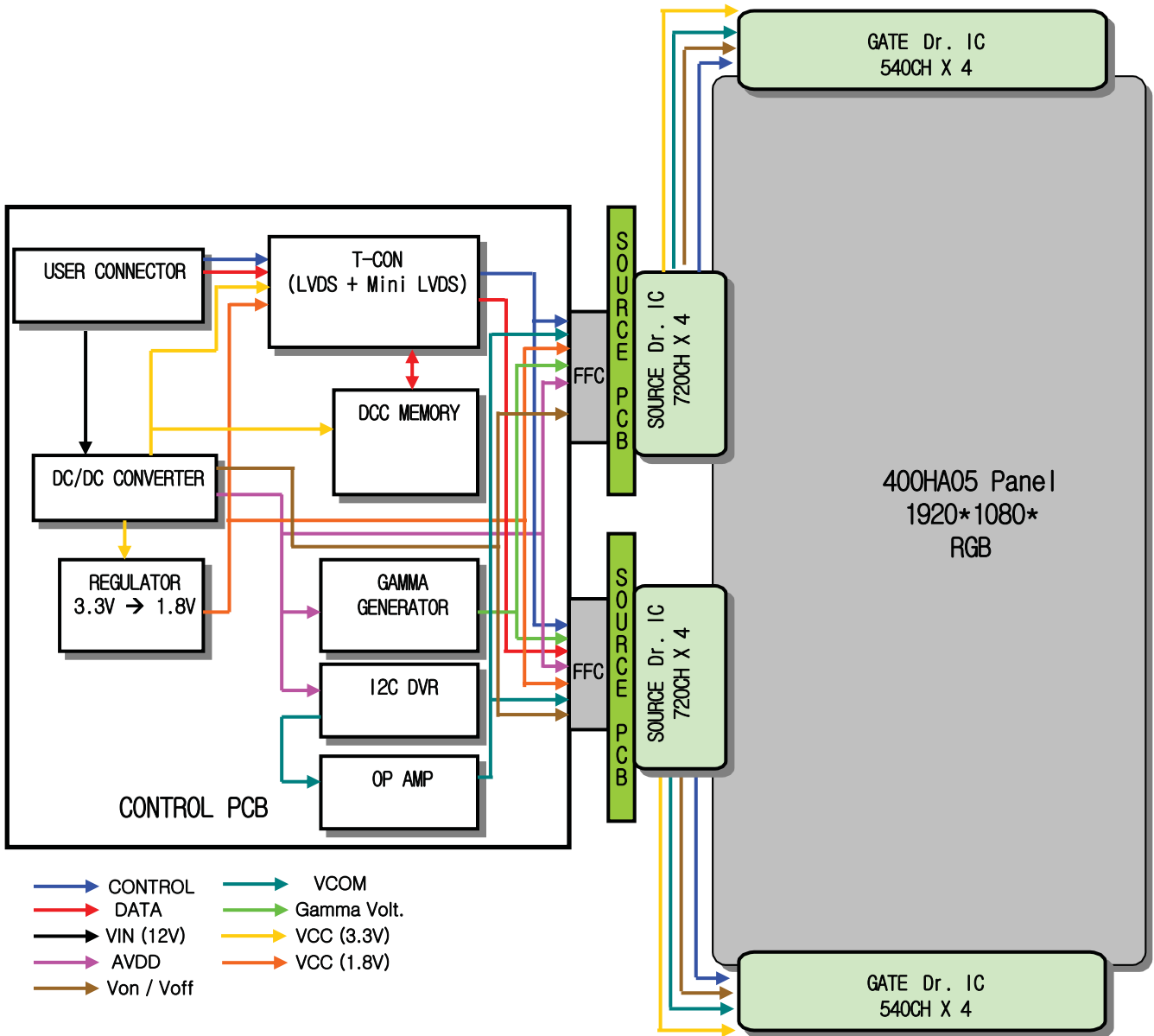

5. Input Terminal Pin Assignment

5.1. Input Signal & Power

Connector : JAE(FI-RE51S_HF)

PIN No.	Signal	Description	PIN No.	Signal	Description
1	Power	V_{DD}	26	LVE[0]P	Even LVDS Signal +
2	Power	V_{DD}	27	LVE[1]N	Even LVDS Signal -
3	Power	V_{DD}	28	LVE[1]P	Even LVDS Signal +
4	Power	V_{DD}	29	LVE[2]N	Even LVDS Signal -
5	Power	V_{DD}	30	LVE[2]P	Even LVDS Signal +
6	N.C.		31	GND	GND
7	GND	GND	32	LVECLK-	Even LVDS Clock-
8	GND	GND	33	LVECLK+	Even LVDS Clock+
9	GND	GND	34	GND	GND
10	LVO[0]N	Odd LVDS Signal -	35	LVE[3]N	Even LVDS Signal -
11	LVO[0]P	Odd LVDS Signal +	36	LVE[3]P	Even LVDS Signal +
12	LVO[1]N	Odd LVDS Signal -	37	LVO[4]N	Even LVDS Signal -
13	LVO[1]P	Odd LVDS Signal +	38	LVO[4]P	Even LVDS Signal +
14	LVO[2]N	Odd LVDS Signal -	39	GND	GND
15	LVO[2]P	Odd LVDS Signal +	40	SCL	I2C SCL
16	GND	GND	41	SDA	I2C SDA
17	LVOCLK-	Odd LVDS CLK -	42	N.C.	
18	LVOCLK+	Odd LVDS CLK +	43	B-INT	Bus Release
19	GND	GND	44	ACC SEL	ACC On/Off
20	LVO[3]N	Odd LVDS Signal -	45	N.C.	
21	LVO[3]P	Odd LVDS Signal +	46	DCC SEL	DCC Select Bit
22	LVO[4]N	Odd LVDS Signal -	47	LUT SEL0	DCC Look-up Table Select
23	LVO[4]P	Odd LVDS Signal +	48	LUT SEL1	
24	GND	GND	49	LUT SEL2	
25	LVE[0]N	Even LVDS Signal -	50	TCON_RDY	T-Con Ready
			51	SEL1	SEC Internal Use Only

■ ACC SEL - HIGH : ACC OFF LOW/OPEN : ACC ON

■ B-INT : I2C BUS RELEASE

L/OPEN	SDA/SCL LINE BECOME HI-Z
H	USER CAN ACCESS EEPROM

■ DCC SELECTION

H	DCC Off
L/OPEN	DCC 1.5 On

■ DCC Look Up Table Selection

Pin N.O.	49	48	47	Description (Based on DCC On)	
				LUT	%(For Interpolate)
Select bit	0	0	0	For 60Hz	100%
	0	0	1	For 60Hz	100%X1.75
	0	1	0	For 60Hz @ Low Temp.	100%
	0	1	1	For 60Hz @ Low Temp.	100%X1.5
	1	0	0	LUT for 50Hz	100%
	1	0	1	LUT for 50Hz	100%X1.25
	1	1	0	0%	
	1	1	1		

■ TCON Ready

Operation	Description
Low → High	Normal Operation
High → Low	Error Operation

Note(1) Pin number starts from Right side

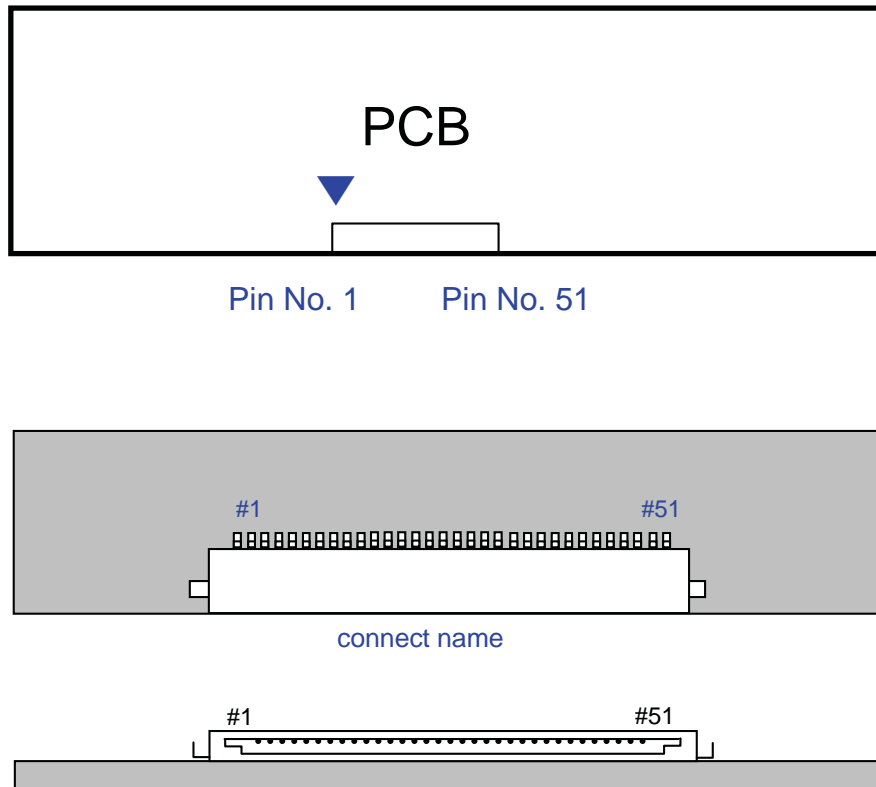

Fig. Connector diagram

- a. All GND pins should be connected together and also be connected to the LCD's metal chassis.
- b. All power input pins should be connected together.
- c. All NC pins should be separated from other signal or power.

5.2. Balance Board

5.2.1 Recommended Operation Condition

Item	Symbol	Recommendation			Unit	Note	Remark
		Min.	Typ.	Max.			
Inverter Frequency	F_{OP}	53	55	57	KHz		Switching Frequency
Dimming Frequency	F_{Dim}	140	150	160	Hz		
Dim Duty Ratio	D_{PWM}	20	-	100	%		Bright Control
Striking Voltage	HV_{Strike}	1740	-	-	Vrms	(1)	

Note

Asymmetric ratio of Total Input Current must be less than 10 % ($|I_p - I_{-p}| / I_{rms@T} < 0.1$)
 Crest factor must be from 90 % to 110 % ($0.9 < I_p / I_{rms@T/2} \times \sqrt{2} < 1.1$)

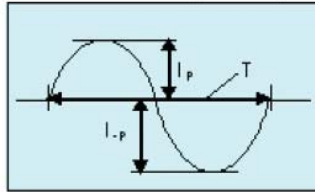

- (1) Striking Voltage (HV_{STRIKE}) based on CCFL spec. for ambient temperature.
 Soft rising time must be
 - at starting time $T_{soft} > 300msec$
 - at PWM dimming condition $T_{rise} < 100usec$

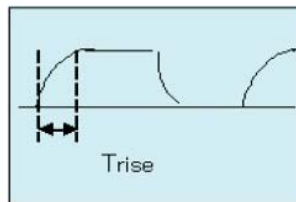
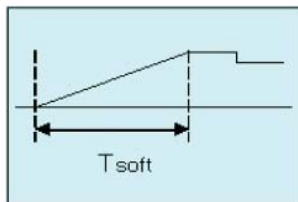

5.2.2 Balance Board Input Pin Configuration

1. HV Input Connector : MDF51SU-2P-13V (Hirose)

PIN NO.	SYMBOL	REMARK
1	HV1	High Voltage Input A
2	HV2	High Voltage Input B

2. HV Input Connector :MDF61-4P-13V (Hirose)

PIN NO.	SYMBOL	REMARK
1	HV1	High Voltage Input A
2	HV2	High Voltage Input B

3. Feed Back Interface : KN30-7P-1.25H (Hirose)

PIN NO.	SYMBOL	REMARK
1	VCC	12V
2	FB	Lamp Current Detected Voltage
3	FB	Lamp Current Detected Voltage
4	GND	Signal Ground
5	GND	Signal Ground
6	LD	CCFL Connector Open & Non-Lighting Signal
7	LD	

5.2.3 Feedback I/O Specification

ITEM	SYMBOL	Recommendation			UNIT	REMARKS
		Min.	Typ.	Max.		
Supply Voltage	V_{CC}	11	12	14	V	Lamp
Input current Of V_{CC}	I_{OC}	20	-	100	mA	at Recommended Load Condition
Lamp Detection	High (Normal)	$V_{CC}-0.5$	-	-	V	@ $V_{CC} = 12$ [V]
	Low (LD)	-	-	1		

5.3 LVDS Interface

- LVDS Receiver : Tcon (merged)

	LVDS pin	Odd Data	Even Data
TxOUT/RxIN0	TxIN/RxOUT0	R4	R4
	TxIN/RxOUT1	R5	R5
	TxIN/RxOUT2	R6	R6
	TxIN/RxOUT3	R7	R7
	TxIN/RxOUT4	R8	R8
	TxIN/RxOUT6	R9	R9
	TxIN/RxOUT7	G4	G4
TxOUT/RxIN1	TxIN/RxOUT8	G5	G5
	TxIN/RxOUT9	G6	G6
	TxIN/RxOUT12	G7	G7
	TxIN/RxOUT13	G8	G8
	TxIN/RxOUT14	G9	G9
	TxIN/RxOUT15	B4	B4
	TxIN/RxOUT18	B5	B5
TxOUT/RxIN2	TxIN/RxOUT19	B6	B6
	TxIN/RxOUT20	B7	B7
	TxIN/RxOUT21	B8	B8
	TxIN/RxOUT22	B9	B9
	TxIN/RxOUT24	HSYNC	HSYNC
	TxIN/RxOUT25	VSYNC	VSYNC
	TxIN/RxOUT26	DEN	DEN
TxOUT/RxIN3	TxIN/RxOUT27	R2	R2
	TxIN/RxOUT5	R3	R3
	TxIN/RxOUT10	G2	G2
	TxIN/RxOUT11	G3	G3
	TxIN/RxOUT16	B2	B2
	TxIN/RxOUT17	B3	B3
	TxIN/RxOUT23	RESERVED	RESERVED
TxIn/RxIn4	TxIn/RxOUT28	R0	R0
	TxIn/RxOUT29	R1	R1
	TxIn/RxOUT30	G0	G0
	TxIn/RxOUT31	G1	G1
	TxIn/RxOUT32	B0	B0
	TxIn/RxOUT33	B1	B1
	TxIn/RxOUT34	RESERVED	RESERVED

5.4 Input Signals, Basic Display Colors and Gray Scale of Each Color

COLOR	DISPLAY (10bit)	DATA SIGNAL																												GRAY SCALE LEVEL
		RED										GREEN										BLUE								
		R0	R1	R2	R3	R4	R5	R6	R7	R8	R9	G0	G1	G2	G3	G4	G5	G6	G7	G8	G9	B0	B1	B2	B3	B4	B5	B6	B7	
BASIC COLOR	BLACK	0	0	0	0	0	0	0	0	0	0	0	0	0	0	0	0	0	0	0	0	0	0	0	0	0	0	0	0	-
	BLUE	0	0	0	0	0	0	0	0	0	0	0	0	0	0	0	0	0	0	0	0	1	1	1	1	1	1	1	1	-
	GREEN	0	0	0	0	0	0	0	0	0	0	1	1	1	1	1	1	1	1	1	1	0	0	0	0	0	0	0	0	-
	CYAN	0	0	0	0	0	0	0	0	0	0	1	1	1	1	1	1	1	1	1	1	1	1	1	1	1	1	1	1	-
	RED	1	1	1	1	1	1	1	1	1	0	0	0	0	0	0	0	0	0	0	0	0	0	0	0	0	0	0	0	-
	MAGENTA	1	1	1	1	1	1	1	1	1	1	0	0	0	0	0	0	0	0	0	0	1	1	1	1	1	1	1	1	-
	YELLOW	1	1	1	1	1	1	1	1	1	1	1	1	1	1	1	1	1	1	1	1	0	0	0	0	0	0	0	0	-
	WHITE	1	1	1	1	1	1	1	1	1	1	1	1	1	1	1	1	1	1	1	1	1	1	1	1	1	1	1	1	-
GRAY SCALE OF RED	BLACK	0	0	0	0	0	0	0	0	0	0	0	0	0	0	0	0	0	0	0	0	0	0	0	0	0	0	0	R0	
	DARK ↑	1	0	0	0	0	0	0	0	0	0	0	0	0	0	0	0	0	0	0	0	0	0	0	0	0	0	0	R1	
		:	:	:	:	:	:	:	:	:	:	:	:	:	:	:	:	:	:	:	:	:	:	:	:	:	:	:	R2	
		:	:	:	:	:	:	:	:	:	:	:	:	:	:	:	:	:	:	:	:	:	:	:	:	:	:	:	R3- R1020	
	↓ LIGHT	1	0	1	1	1	1	1	1	1	1	0	0	0	0	0	0	0	0	0	0	0	0	0	0	0	0	0	R1021	
		0	1	1	1	1	1	1	1	1	1	0	0	0	0	0	0	0	0	0	0	0	0	0	0	0	0	0	R1022	
	RED	1	1	1	1	1	1	1	1	1	1	0	0	0	0	0	0	0	0	0	0	0	0	0	0	0	0	0	R1023	
	GRAY SCALE OF GREEN	BLACK	0	0	0	0	0	0	0	0	0	0	0	0	0	0	0	0	0	0	0	0	0	0	0	0	0	0	0	G0
DARK ↑		0	0	0	0	0	0	0	0	0	0	1	0	0	0	0	0	0	0	0	0	0	0	0	0	0	0	0	G1	
		0	0	0	0	0	0	0	0	0	0	0	1	0	0	0	0	0	0	0	0	0	0	0	0	0	0	0	G2	
		:	:	:	:	:	:	:	:	:	:	:	:	:	:	:	:	:	:	:	:	:	:	:	:	:	:	:	G3- G1020	
↓ LIGHT		0	0	0	0	0	0	0	0	0	0	1	0	1	1	1	1	1	1	1	1	0	0	0	0	0	0	0	G1021	
		0	0	0	0	0	0	0	0	0	0	0	1	1	1	1	1	1	1	1	1	0	0	0	0	0	0	0	G1022	
GREEN		0	0	0	0	0	0	0	0	0	0	1	1	1	1	1	1	1	1	1	1	0	0	0	0	0	0	0	G1023	
GRAY SCALE OF BLUE		BLACK	0	0	0	0	0	0	0	0	0	0	0	0	0	0	0	0	0	0	0	0	0	0	0	0	0	0	0	B0
	DARK ↑	0	0	0	0	0	0	0	0	0	0	0	0	0	0	0	0	0	0	0	0	1	0	0	0	0	0	0	B1	
		0	0	0	0	0	0	0	0	0	0	0	0	0	0	0	0	0	0	0	0	0	1	0	0	0	0	0	B2	
		:	:	:	:	:	:	:	:	:	:	:	:	:	:	:	:	:	:	:	:	:	:	:	:	:	:	:	B3- B1020	
	↓ LIGHT	0	0	0	0	0	0	0	0	0	0	0	0	0	0	0	0	0	0	0	0	1	0	1	1	1	1	1	B1021	
		0	0	0	0	0	0	0	0	0	0	0	0	0	0	0	0	0	0	0	0	1	1	1	1	1	1	1	B1022	
	BLUE	0	0	0	0	0	0	0	0	0	0	0	0	0	0	0	0	0	0	0	0	1	1	1	1	1	1	1	B1023	

Note) Definition of Gray :
 Rn : Red Gray, Gn : Green Gray, Bn : Blue Gray (n = Gray level)
 Input Signal : 0 = Low level voltage, 1 = High level voltage

6. Interface Timing

6.1 Timing Parameters (DE only mode)

SIGNAL	ITEM	SYMBOL	MIN.	TYP.	MAX.	Unit	NOTE
Clock	Frequency	$1/T_C$	130	148.5	155	MHz	-
Hsync		F_H	50	67.5	73	KHz	-
Vsync		F_V	47	60	62	Hz	-
Vertical Display Term	Active Display Period	T_{VD}	-	1080	-	lines	-
	Vertical Total	T_{VB}	1100	1125	1480	Lines	-
Horizontal Display Term	Active Display Period	T_{HD}	-	1920	-	clocks	-
	Horizontal Total	T_H	2154	2200	2450	clocks	-

Note) This product is DE only mode. The input of Hsync & Vsync signal does not have an effect on normal operation.

(1) Test Point : TTL control signal and CLK at LVDS Tx input terminal in system

(2) Internal $V_{DD} = 3.3V$

6.2 Timing diagrams of interface signal (DE only mode)

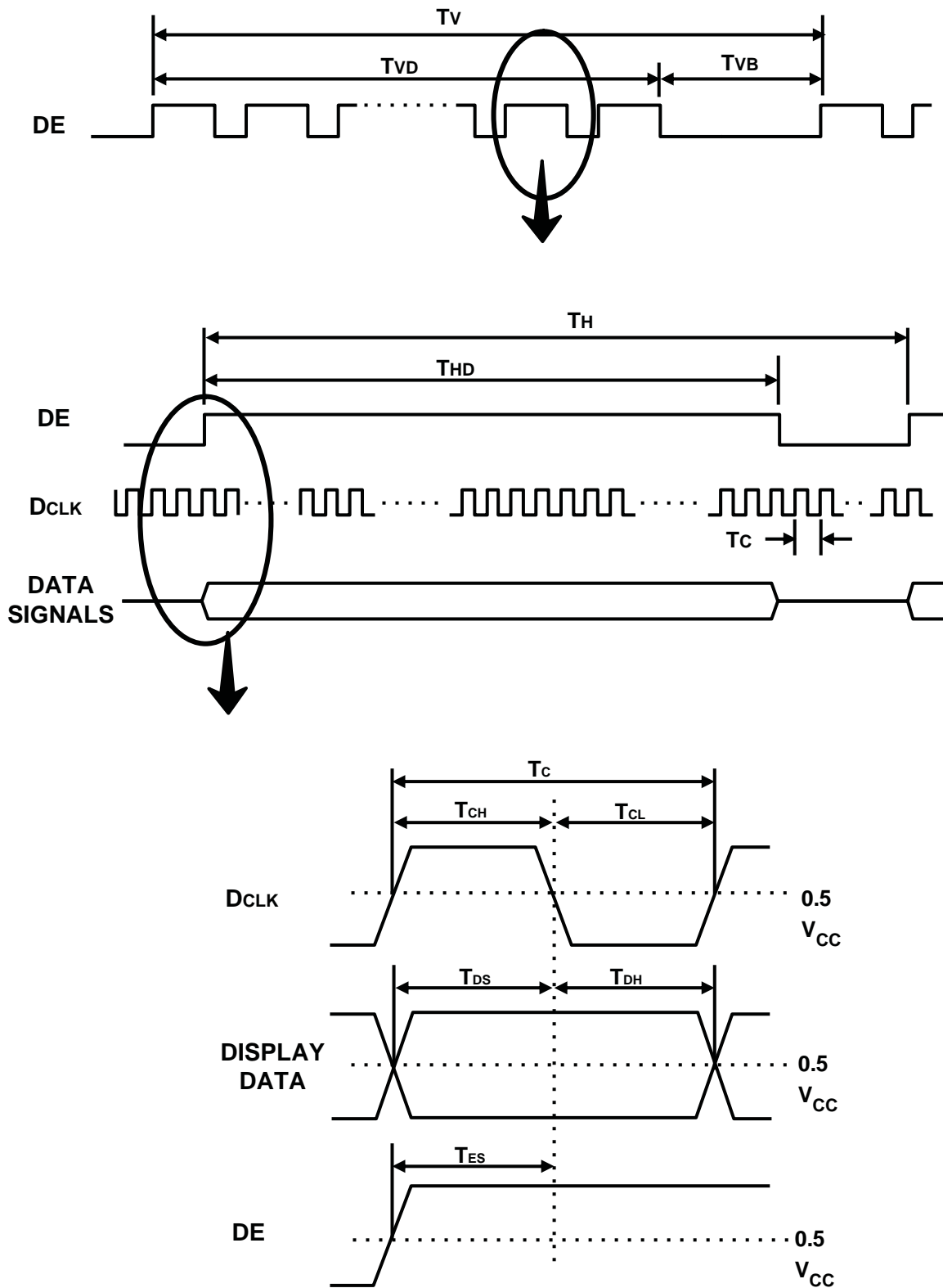

6.3 Power ON/OFF Sequence

To prevent a latch-up or DC operation of the LCD Module, the power on/off sequence should be as the diagram below.

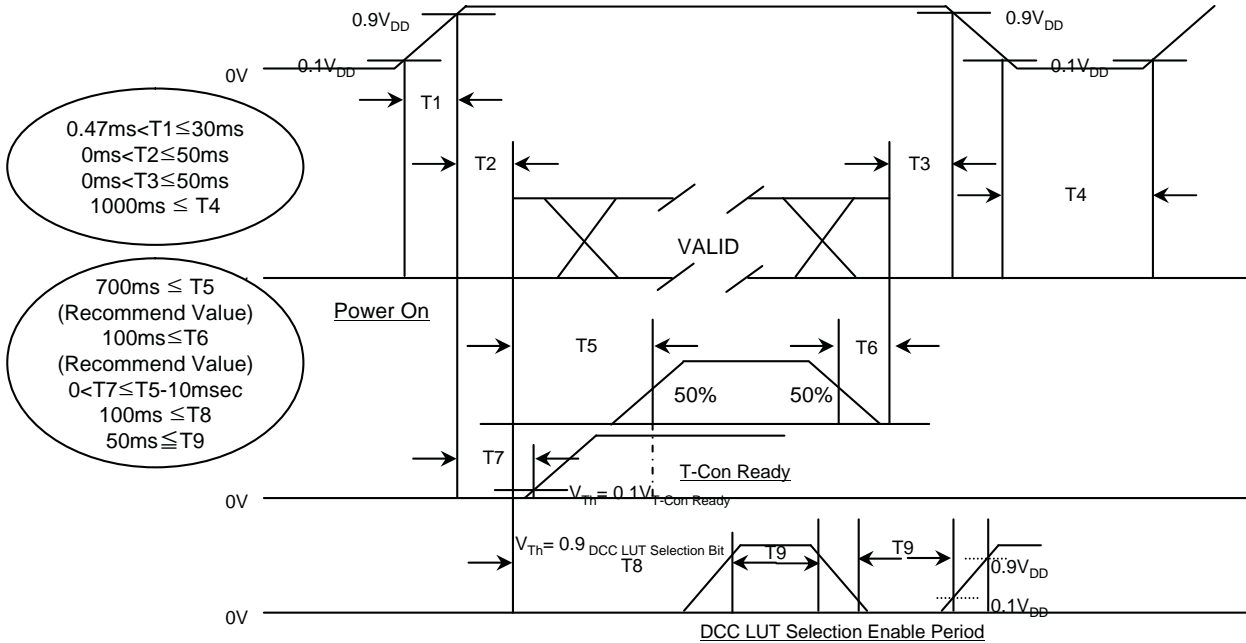

- T1: V_{DD} rising time from 10% to 90%
- T2: The Time from V_{DD} to data at power On.
- T3: The time from valid data off to V_{DD} off at power off.
- T4: V_{DD} off time for TV SET restart
- T5: The time from valid data to B/L enable at power ON.
- T6: The time from valid data off to B/L disable at power off.
- T7: The time from V_{in} to T-Con Ready
- T8 : The Time from Valid Data to DCC LUT Selection Enable Period.
- T9 : The Time from DCC LUT Switching point to next it.

- The supply voltage of the external system for the Module input should be the same as the definition of V_{DD} .
- Apply the lamp voltage within the LCD operation range. When the back light turns on before the LCD operation or the LCD turns off before the back light turns off, the display may momentarily show abnormal screen.
- In case of $V_{DD} = \text{off level}$, please keep the level of input signals low or keep a high impedance.
- T4 should be measured after the Module has been fully discharged between power off and on period.
- Interface signal should not be kept at high impedance when the power is on.

7. Outline dimension (Front view)

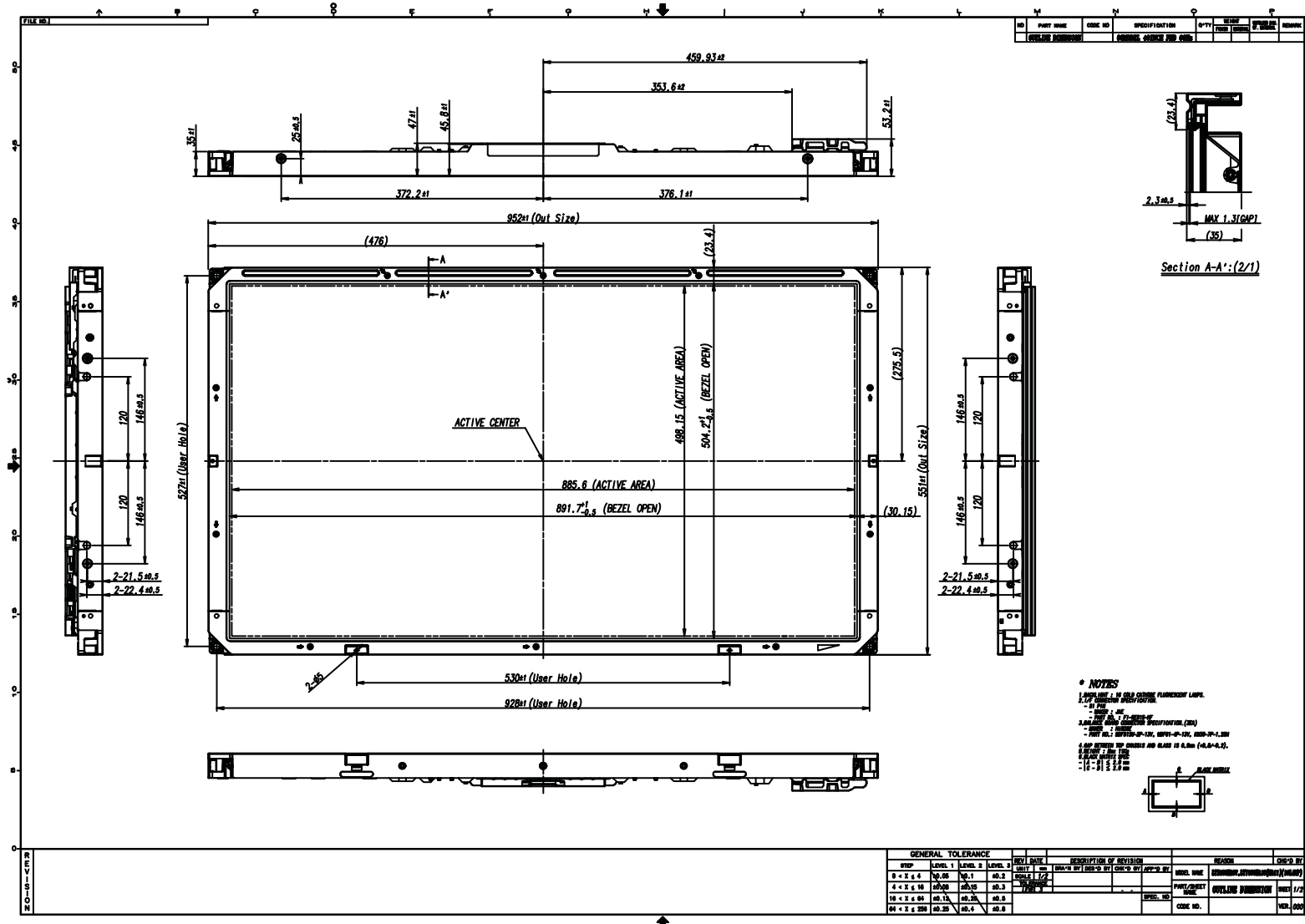

Outline dimension (Rear View)

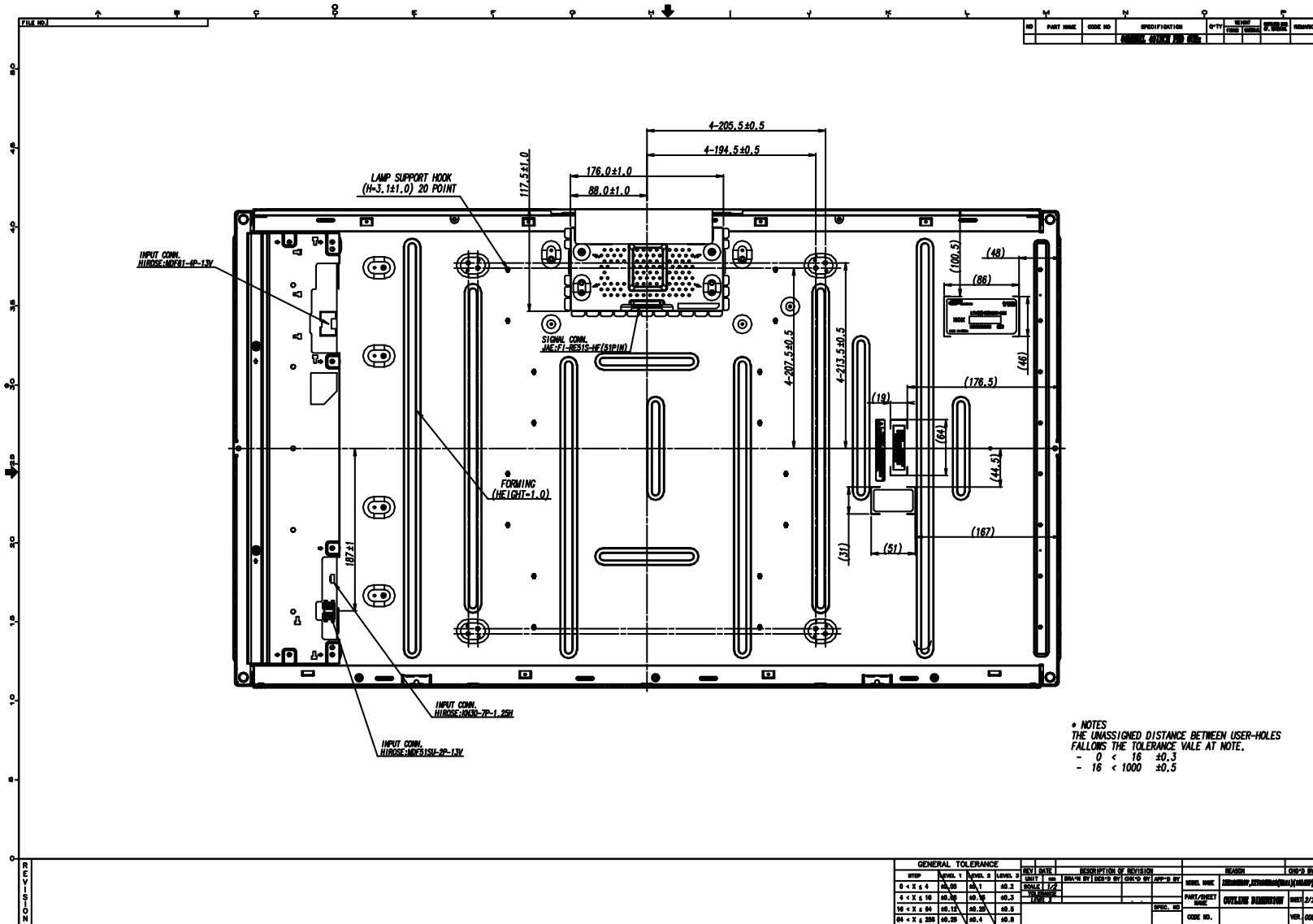

MODEL

LTY400HA10

Doc. No

05-001-S-091029

Page

24 / 31

8. EMI Specification

: -3dB at CISPR22 Class B

This EMI Recommendation is recommended to be measured as SET Condition.

9. Input Spread Spectrum Specification

	Modulation Ratio (Max.)	Modulation Frequency (Min.)	Modulation Frequency (Max.)
Input Signal	$\pm 1.2\%$	50KHz	200KHz

10. UL Approval

11. Reliability Test

Item	Test condition	Quantity
Temperature Step Stress	0 ~ 50℃, 10Cycle determination	4EA
HTOL	50℃, 1000hr (500hr determination)	8EA
LTOL	0℃, 1000hr (500hr determination)	4EA
RTOL	20℃, continue ~	4EA
HTS	70℃, 1000hr (500hr determination)	4EA
LTS	-30℃, 1000hr (500hr determination)	4EA
THB	40℃ / 95%RH, 1000hr (500hr determination)	4EA
WHTS	60℃ / 75%RH, 1000hr (500hr determination)	4EA
T/C	-20℃ ~ 60℃, 200cycle (100cycle determination)	4EA
ESD (non-operation)	± 10 kV, 200pF/100 Ω, 9Point, 3times/Point	3EA
ESD(operation)	contact : ± 8 kV, 150pF/330 Ω, 210Point, 1 time/Point non-contact : ± 15 kV, 150pF/330 Ω, 100Point, 1 time/Point	3EA
Input Con. ESD	contact : ± 2kV, 200pF/100, Input Con.Pin, 3 times/Pin	3EA
POWER ON/OFF	30sec (on) / 30sec(off) : 12,000 times	4EA
Vibration	10~300Hz/1.5G/10minSR, XYZ, 30min/axis	3EA
Shock	SEC condition : 11msec, ± XYZ 1time/axis 50G	3EA
PALLET Vibration	1.146 Grms, 2~200Hz, Random, Z axis 1Hr	1PALLET(10EA)
PALLET Drop	20cm, Bottom, Front, Rear 1times	1PALLET(10EA)

[Result Evaluation Criteria]

Under the display quality test conditions with normal operation state, these shall be no change which may affect practical display function.

HTOL/ LTOL : High/Low Temperature Operating Life,
 THB : Temperature Humidity Bias
 HTS/LTS : High/Low Temperature Storage
 WHTS : Wet High Temperature Storage

12. PACKING

12.1 CARTON (Internal Package)

(1) Packing Form

Corrugated fiberboard box and corrugated cardboard as shock absorber

(2) Packing Method

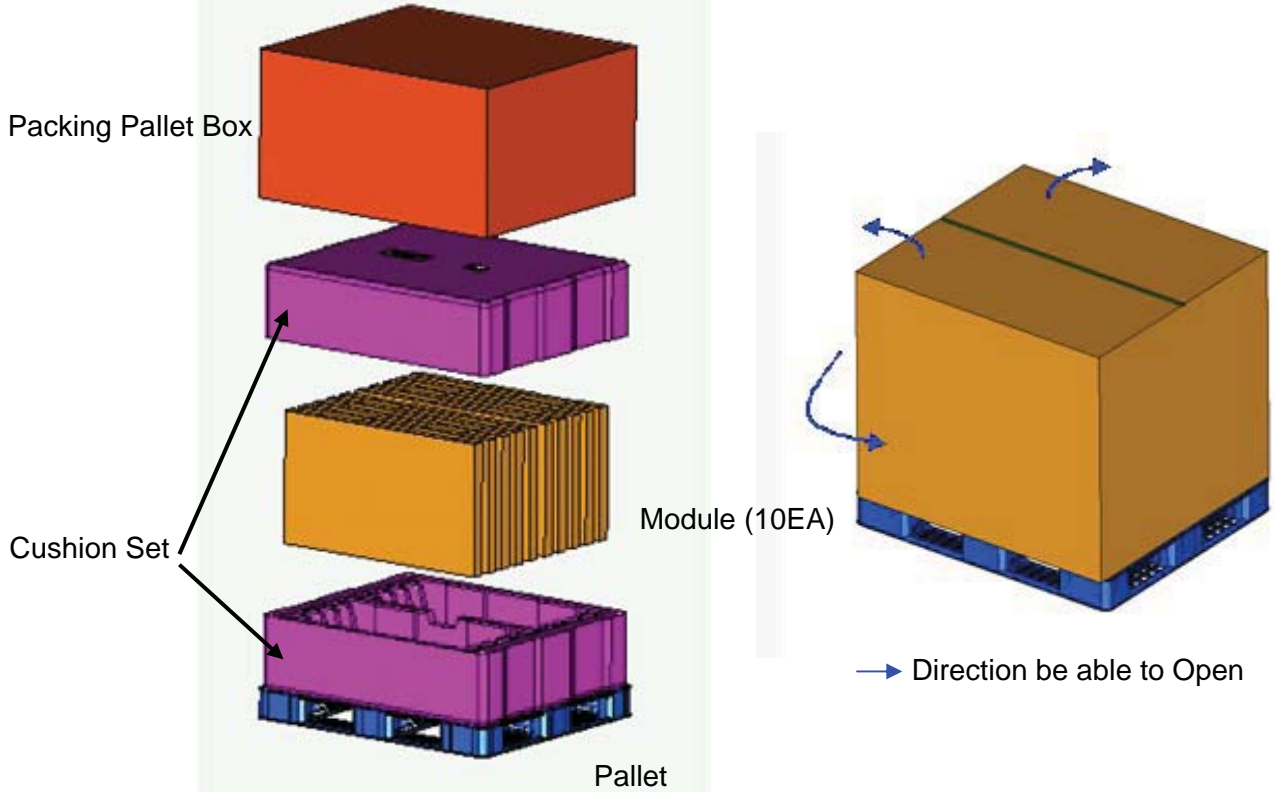

12.2 Packing Specification

Item	Specification	Remark
LCD Packing	10 ea / (Packing-Pallet Box)	1. 110Kg/LCD(10ea) 2. 7kg/Cushion Set(2ea) 3. 6.7kg/Packing-Pallet Box(1 ea) 4. Cushion Material : EPS 5. Packing Pallet Box Material : DW4
Pallet	1 Box / Pallet	Pallet weight : 8kg
Packing Direction	Vertical	-
Total Pallet Size	H x V x height	1150mm(H) x 985mm(V) x 609mm(Height)
Total Pallet Weight	131.7kg	Pallet(8kg) + Module(12 x 10 = 120kg) + Cushion(7kg) + Pallet-BOX(6.7kg)

13. MARKING & OTHERS

A nameplate bearing followed by is affixed to a shipped product at the specified location on each product.

- (1) Parts number : LTY400HA10
- (2) Revision: 3 letters
- (3) Lot number : X X X X XXX XX X

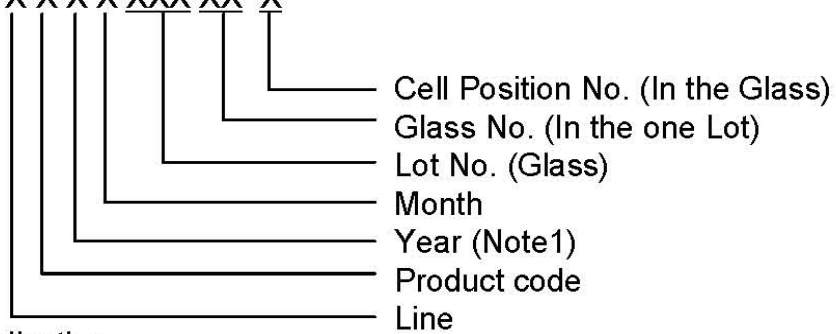

(4) Nameplate Indication

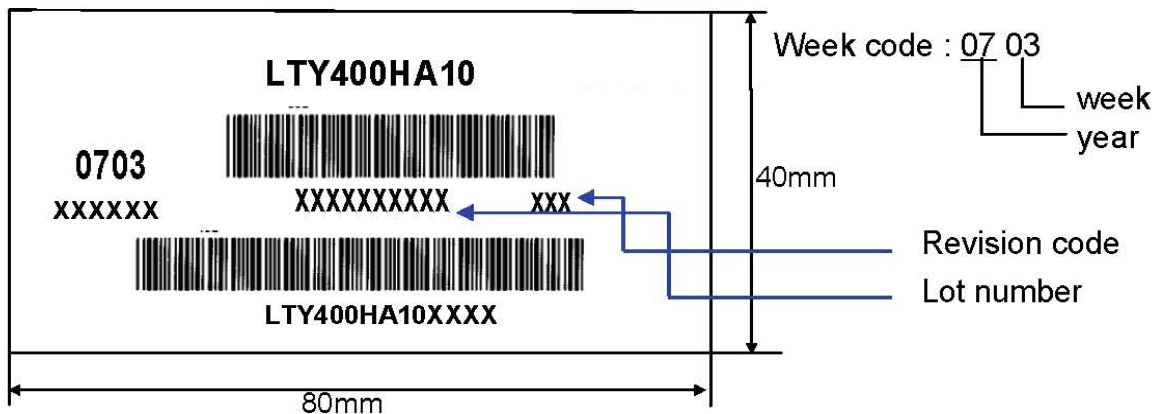

(5) Packing box attach

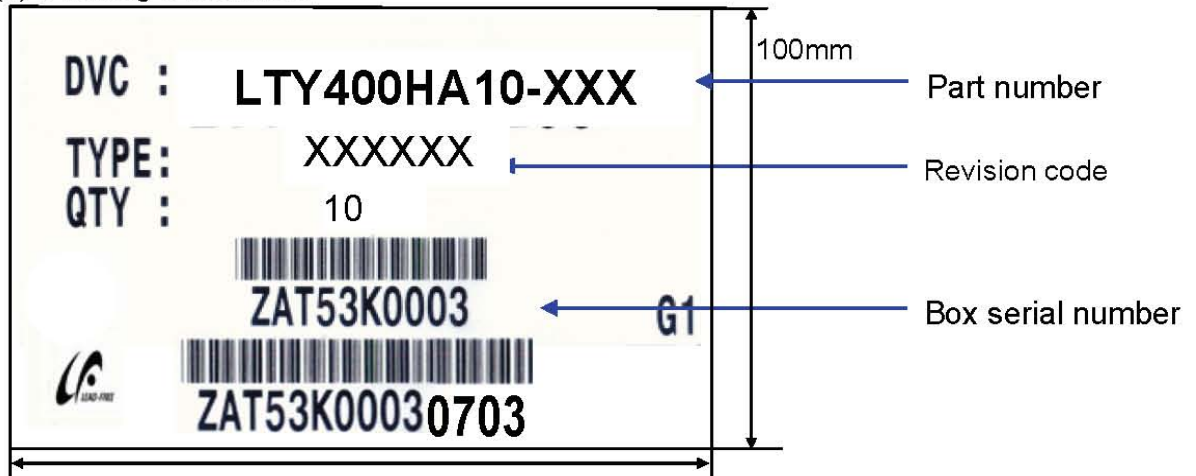

(6) Others

- 1. After service part
 Lamps cannot be replaced because of the narrow bezel structure.

MODEL	LTY400HA10	Doc. No	05-001-S-091029	Page	28 / 31
-------	------------	---------	-----------------	------	---------

14. General Precautions

14.1 Handling

- (a) When the Module is assembled, it should be attached to the system firmly using all mounting holes. Be careful not to twist and bend the Module.
- (b) Because the inverter use high voltage, it should be disconnected from power before it is assembled or disassembled.
- (c) Refrain from strong mechanical shock and / or any force to the Module.
In addition to damage, this may cause improper operation or damage to the Module and CCFT back light.
- (d) Note that polarizers are very fragile and could be damage easily.
Do not press or scratch the surface harder than a HB pencil lead.
- (e) Wipe off water droplets or oil immediately. If you leave the droplets for a long time, staining or discoloration may occur.
- (f) If the surface of the polarizer is dirty, clean it using absorbent cotton or soft cloth.
- (g) Desirable cleaners are water, IPA(Isopropyl Alcohol) or Hexane.
Do not use Ketone type materials(ex. Acetone), Ethyl alcohol, Toluene, Ethyl acid or Methyl chloride. It might permanent damage to the polarizer due to chemical reaction.
- (h) If the liquid crystal material leaks from the panel, it should be kept away from the eyes or mouth . In case of contact with hands, legs or clothes, it must be washed away with soap thoroughly.
- (i) Protect the Module from static, or the CMOS Gate Array IC would be damaged.
- (j) Use finger-stalls with soft gloves in order to keep display clean during the incoming inspection and assembly process.
- (k) Do not disassemble the Module.
- (l) Do not pull or fold the lamp wire.
- (m) Do not adjust the variable resistor located on the Module.
- (n) Protection film for polarizer on the Module should be slowly peeled off just before use so that the electrostatic charge can be minimized.
- (o) Pins of I/F connector should not be touched directly with bare hands.

14.2 Storage

- (a) Do not leave the Module in high temperature, and high humidity for a long time. It is highly recommended to store the Module with temperature from 0 to 35°C and relative humidity of less than 70%.
- (b) Do not store the TFT-LCD Module in direct sunlight.
- (c) The Module should be stored in a dark place. It is prohibited to apply sunlight or fluorescent light in storing.

14.3 Operation

- (a) No Connection or disconnect the Module in the "Power On" condition.
- (b) Power supply should always be turned on/off by the "Power on/off sequence"
- (c) Module has high frequency circuits. Sufficient suppression to the electromagnetic interference should be done by system manufacturers. Grounding and shielding methods may be important to minimize the interference.
- (d) The cable between the back light connector and its inverter power supply should be connected directly with a minimized length. A longer cable between the back light and the inverter may cause lower luminance of lamp(CCFT) and may require higher startup voltage(Vs).

14.4 Operation Condition Guide

- (a) The LCD product should be operated under normal conditions.
Normal condition is defined as below;
 - Temperature : $20 \pm 15^{\circ}\text{C}$
 - Humidity : $55 \pm 20\%$
 - Display pattern : continually changing pattern (Not stationary)
- (b) If the product will be used in extreme conditions such as high temperature, humidity, display patterns or operation time etc., It is strongly recommended to contact SEC for Application engineering advice. Otherwise, its reliability and function may not be guaranteed. Extreme conditions are commonly found at Airports, Transit Stations, Banks, Stock market, and Controlling systems.

MODEL	LTY400HA10	Doc. No	05-001-S-091029	Page	30 / 31
-------	------------	---------	-----------------	------	---------

14.5 Others

- (a) Ultra-violet ray filter is necessary for outdoor operation.
- (b) Avoid condensation of water. It may result in improper operation or disconnection of electrode.
- (c) Do not exceed the absolute maximum rating value. (supply voltage variation, input voltage variation, variation in part contents and environmental temperature, and so on)
Otherwise the Module may be damaged.
- (d) If the Module keeps displaying the same pattern for a long period of time, the image may be "sticked" to the screen.
To avoid image sticking, it is recommended to use a screen saver.
- (e) This Module has its circuitry PCB's on the rear side and should be handled carefully in order not to be stressed.
- (f) Please contact SEC in advance when you display the same pattern for a long time.