

Contents

Revision History	(3)
General Description	(4)
General Information	(4)
1. Absolute Maximum Ratings	(5)
2. Optical Characteristics	(6)
3. Electrical Characteristics	(9)
3.1 TFT LCD Module	
3.2 Back Light Unit	
4. Block Diagram	(11)
5. Input Terminal Pin Assignment	(12)
5.1 Input Signal & Power	
5.2 Inverter Input Pin Configuration	
5.3 Inverter Input Power Sequence & Specification	
5.4 LVDS Interface	
5.5 Input Signals, Basic Display Colors and Gray Scale of Each Color	
6. Interface Timing	(17)
6.1 Timing Parameters (DE only mode)	
6.2 Timing Diagrams of interface Signal (DE only mode)	
6.3 Power ON/OFF Sequence	
7. Outline Dimension	(20)
8. EMI Specification	(22)
9. UL Approval	
10. Reliability Test	(23)
11. Packing	(24)
12. Marking & Others	(25)
13. General Precaution	(26)
13.1 Handling	
13.2 Storage	
13.3 Operation	
13.4 Operation Condition Guide	
13.5 Others	

General Description

Description

LTY[Z]400WS-L02 is a color active matrix liquid crystal display (LCD) that uses amorphous silicon TFT (Thin Film Transistor) as switching components. This model is composed of a TFT LCD panel, a driver circuit and a back light unit. The resolution of a 40.0" is 1366 x 768 and this model can display up to 16.7 million colors with wide viewing angle of 89° or higher in all directions. This panel is intended to support applications to provide a excellent performance for Flat Panel Display such as Home-alone Multimedia TFT-LCD TV, Display terminals for AV application products, and High Definition TV (HDTV).

Features

- RoHS compliance (Pb-free)
- High contrast ratio, high aperture ratio, fast response time
- SPVA (Super Patterned Vertical Align) mode
- Wide viewing angle ($\pm 89^\circ$)
- High speed response
- WXGA (1366 x 768 pixels) resolution (16:9)
- Low Power consumption
- 20 CCFTs (Cold Cathode Fluorescent Tube)
- DE (Data Enable) mode
- LVDS (Low Voltage Differential Signaling) interface (1pixel/clock)

General Information

Items	Specification	Unit	Note
Module Size	952.0(H _{TYP}) x 551.0(V _{TYP})	mm	±1.0mm
	52.0(D _{MAX})		
Weight	12,000(Max)	g	
Pixel Pitch	0.648(H) x 0.216(W)*3	mm	
Active Display Area	885.168(H) x 497.664(V)	mm	
Surface Treatment	Haze 44% , Hard-coating (3H)		
Display Colors	8 bit - 16.7M	colors	
Number of Pixels	1366 x 768	pixel	
Pixel Arrangement	RGB vertical stripe		
Display Mode	Normally Black		
Luminance of White	530	cd/m ²	

MODEL	LTY[Z]400WS-L02	Doc. No	05-006-S-070109	Page	4 / 28
-------	-----------------	---------	-----------------	------	--------

1. Absolute Maximum Ratings

If the condition exceeds maximum ratings, it can cause malfunction or unrecoverable damage to the device.

Item	Symbol	Min.	Max.	Unit	Note
Power Supply Voltage	V_{DD}	GND-0.5	5.5	V	(1)
Storage temperature	T_{STG}	-20	65	°C	(2)
Operating Temperature	T_{OPR}	0	50	°C	
Panel surface temperature	T_{SUR}	0	65	°C	(3)
Shock (non - operating)	S_{NOP}	-	50	G	(4)
Vibration (non - operating)	V_{NOP}	-	1.5	G	(5)

Note (1) $T_a = 25 \pm 2 \text{ }^\circ\text{C}$

(2) Temperature and relative humidity range are shown in the figure below.

a. 90 % RH Max. ($T_a \leq 39 \text{ }^\circ\text{C}$)

b. Maximum wet-bulb temperature at $39 \text{ }^\circ\text{C}$ or less. ($T_a \leq 39 \text{ }^\circ\text{C}$)

c. No condensation

(3) Polarizer will not be damaged in this range, even though abnormal visual problems occur in T_{SUR} range.

(4) 11ms, sine wave, one time for $\pm X, \pm Y, \pm Z$ axis

(5) 10-300 Hz, Sweep rate 10min, 30min for X,Y,Z axis

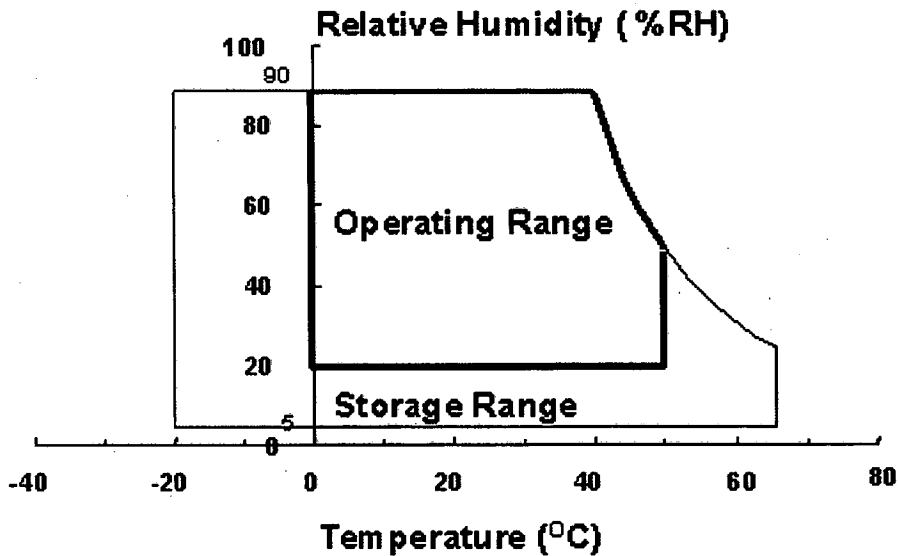

Fig. Temperature and Relative humidity range

2. Optical Characteristics

The optical characteristics should be measured in a dark room or equivalent.

Measuring equipment : TOPCON BM-7,SPECTRORADIOMETER SR-3

($T_a = 25 \pm 2^\circ\text{C}$, $V_{DD}=5\text{V}$, $f_v= 60\text{Hz}$, $f_{DCLK}=80\text{MHz}$, $V_{dim} = 2.0\text{V}$)

Item	Symbol	Condition	Min.	Typ.	Max.	Unit	Note	
Contrast Ratio (Center of screen)	C/R		800	1200	-		(3) SR-3	
Response Time	Rising	Tr	-	10[20]	13[25]	Msec	[DCC1] (5) BM-7	
	Falling	Tf	-	6	10			
	G-to-G	Tg	-	8[10]	-			
Luminance of White (Center of screen)	Y_L	Normal $\theta_{L,R}=0$ $\theta_{U,D}=0$	430	530	-	cd/m ²	(6) SR-3	
Color Chromaticity (CIE 1931)	Red	Rx	TYP. -0.03	0.640	TYP. +0.03		(7),(8) SR-3	
		Ry		0.333				
	Green	Gx		0.275				
		Gy		0.595				
	Blue	Bx		0.143				
		By		0.064				
	White	Wx		0.280				
		Wy		0.290				
Color Gamut	-	-	72	-	-	%	(7) SR-3	
Color Temperature	-	-	-	10000	-	K	(7) SR-3	
Viewing Angle	Hor.	θ_L	C/R \geq 10	75	89	-	Degree	(8) SR-3
		θ_R		75	89	-		
	Ver.	θ_U		75	89	-		
		θ_D		75	89	-		
Brightness Uniformity (9 Points)	B_{uni}		-	-	*(30)	%	(4) SR-3	

*Max Brightness Uniformity will be decided after taking data of early mass production.

Note (1) Test Equipment Setup

The measurement should be executed in a stable, windless and dark room between 40min and 60min after lighting the back light at the given temperature for stabilization of the back light. This should be measured in the center of screen.

Single lamp current @ $V_{dim} = 2.0\text{V}$
Environment condition : $T_a = 25 \pm 2^\circ\text{C}$

MODEL	LTY[Z]400WS-L02	Doc. No	05-006-S-070109	Page	6 / 28
-------	-----------------	---------	-----------------	------	--------

Photo detector	Field
SR-3	1°
BM-7	2°

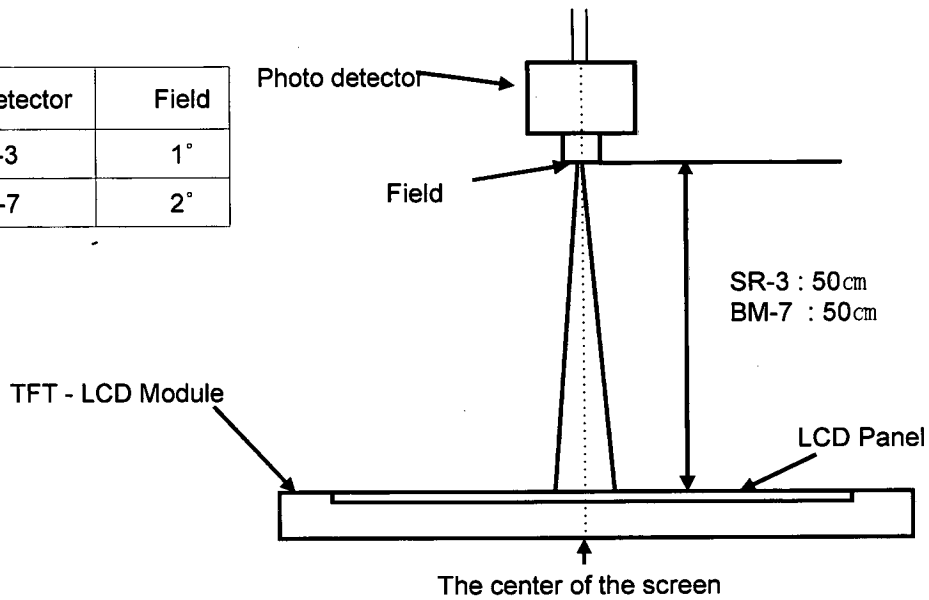

Note (2) Definition of test point

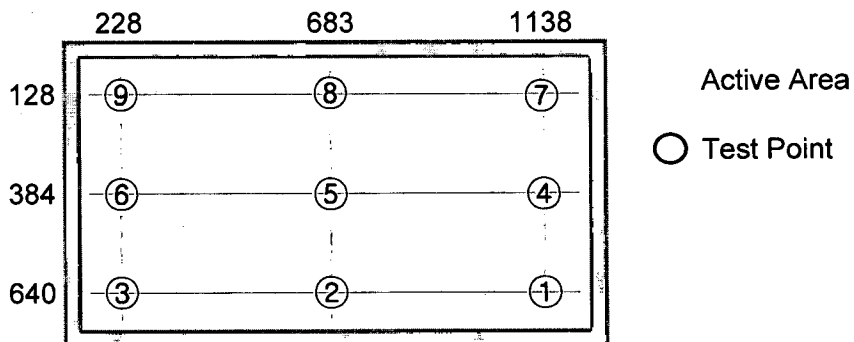

Note (3) Definition of Contrast Ratio (C/R)

: Ratio of gray max (Gmax) & gray min (Gmin) at the center point ⑤ of the panel

$$C/R = \frac{G_{\max}}{G_{\min}}$$

Gmax : Luminance with all pixels white

Gmin : Luminance with all pixels black

Note (4) Definition of 9 points brightness uniformity

$$B_{uni} = 100 * \frac{(B_{max} - B_{min})}{B_{max}}$$

Bmax : Maximum brightness

Bmin : Minimum brightness

Note (5) Definition of Response time : Sum of Tr, Tf

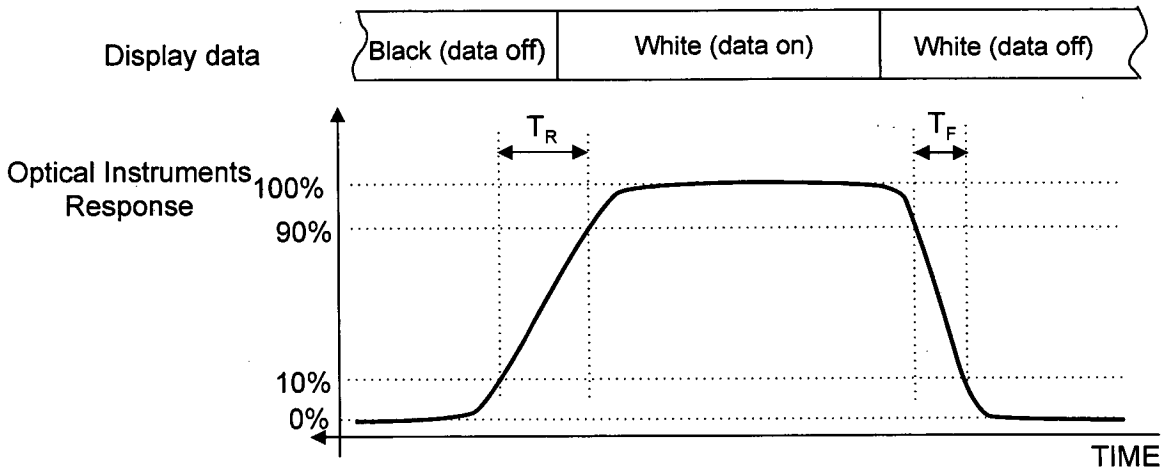

Note (6) Definition of Luminance of White : Luminance of white at center point ⑤

Note (7) Definition of Color Chromaticity (CIE 1931)

Color coordinate of Red, Green, Blue & White at center point ⑤

Note (8) Definition of Viewing Angle

: Viewing angle range (C/R • 40)

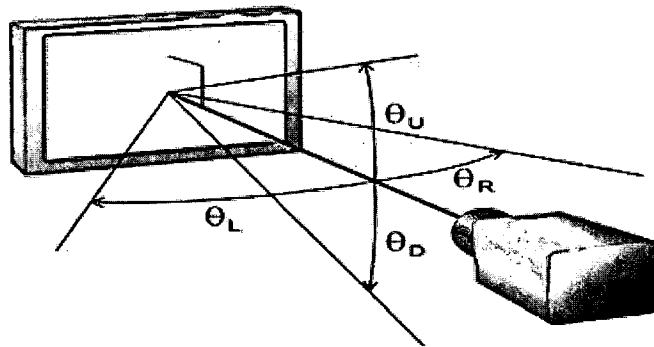

3. Electrical Characteristics

3.1 TFT LCD Module

The connector for display data & timing signal should be connected.

$T_a = 25^\circ\text{C} \pm 2^\circ\text{C}$

Item	Symbol	Min.	Typ.	Max.	Unit	Note
Voltage of Power Supply	V_{DD}	4.5	5.0	5.5	V	(1)
Current of Power Supply	(a) Black	-	1500	-	mA	(2),(3)
	(b) White	-	1700	2000	mA	
	(c) Mosaic	-	1600	-	mA	
Vsync Frequency	f_V	47	60	66	Hz	
Hsync Frequency	f_H	43	48	53	kHz	
Main Frequency	f_{DCLK}	60	80	82	MHz	
Rush Current	I_{RUSH}	-	-	5	A	(4)

Note (1) The ripple voltage should be controlled under 10% of V_{DD} .

(2) $f_V=60\text{Hz}$, $f_{DCLK} = 80\text{MHz}$, $V_{DD} = 5.0\text{V}$, DC Current.

(3) Power dissipation check pattern (LCD Module only)

a) Black Pattern

b) White Pattern

c) Mosaic

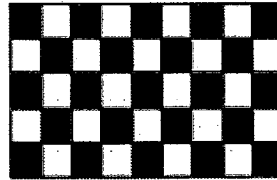
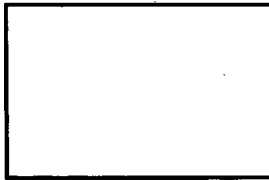
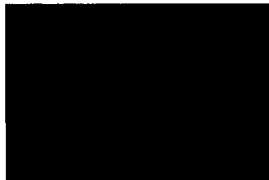

(4) Measurement Conditions

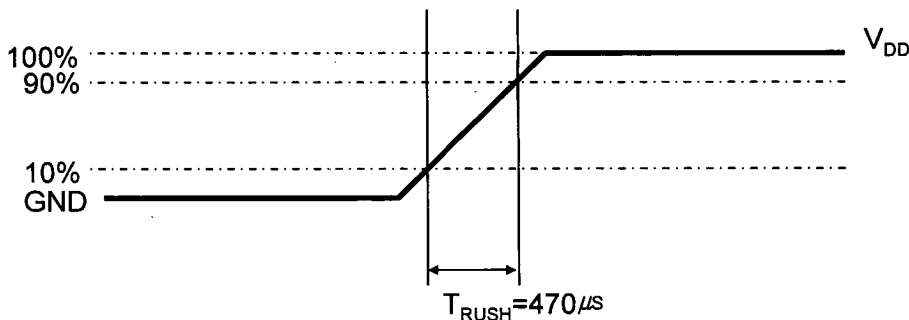

Rush Current I_{RUSH} can be measured when T_{RUSH} is $470\mu\text{s}$.

3.2 Back Light Unit

The back light unit contains 20 CCFTs (Cold Cathode Fluorescent Tube).

Ta=25 ± 2°C

Item	Symbol	Min.	Typ.	Max.	Unit	Note
Operating Life Time	Hr	50,000	-	-	Hour	(1)

Note (1) It is defined as the time to take until the brightness reduces to 50% of its original value.

[Operating condition : Ta = 25±2°C, I_L = 6 mArms(typ.), For single lamp only.]

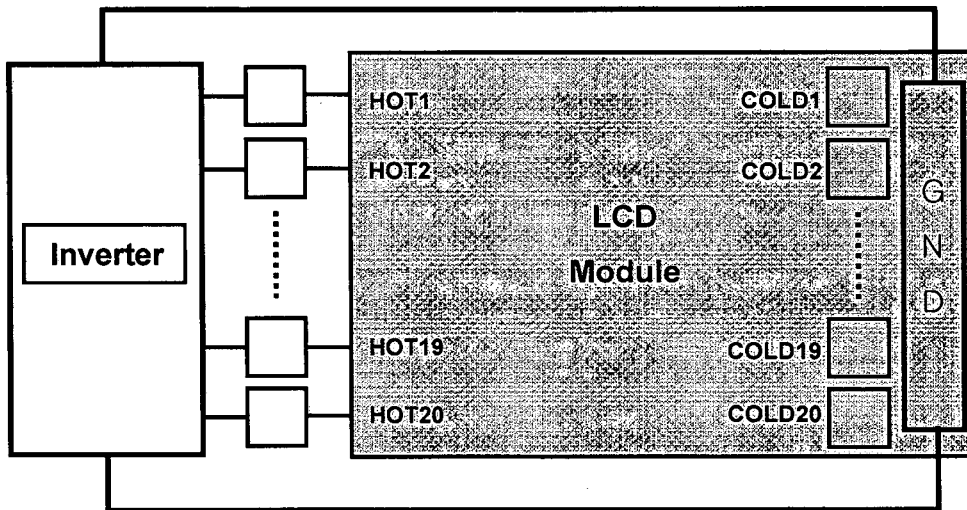

4. Block Diagram

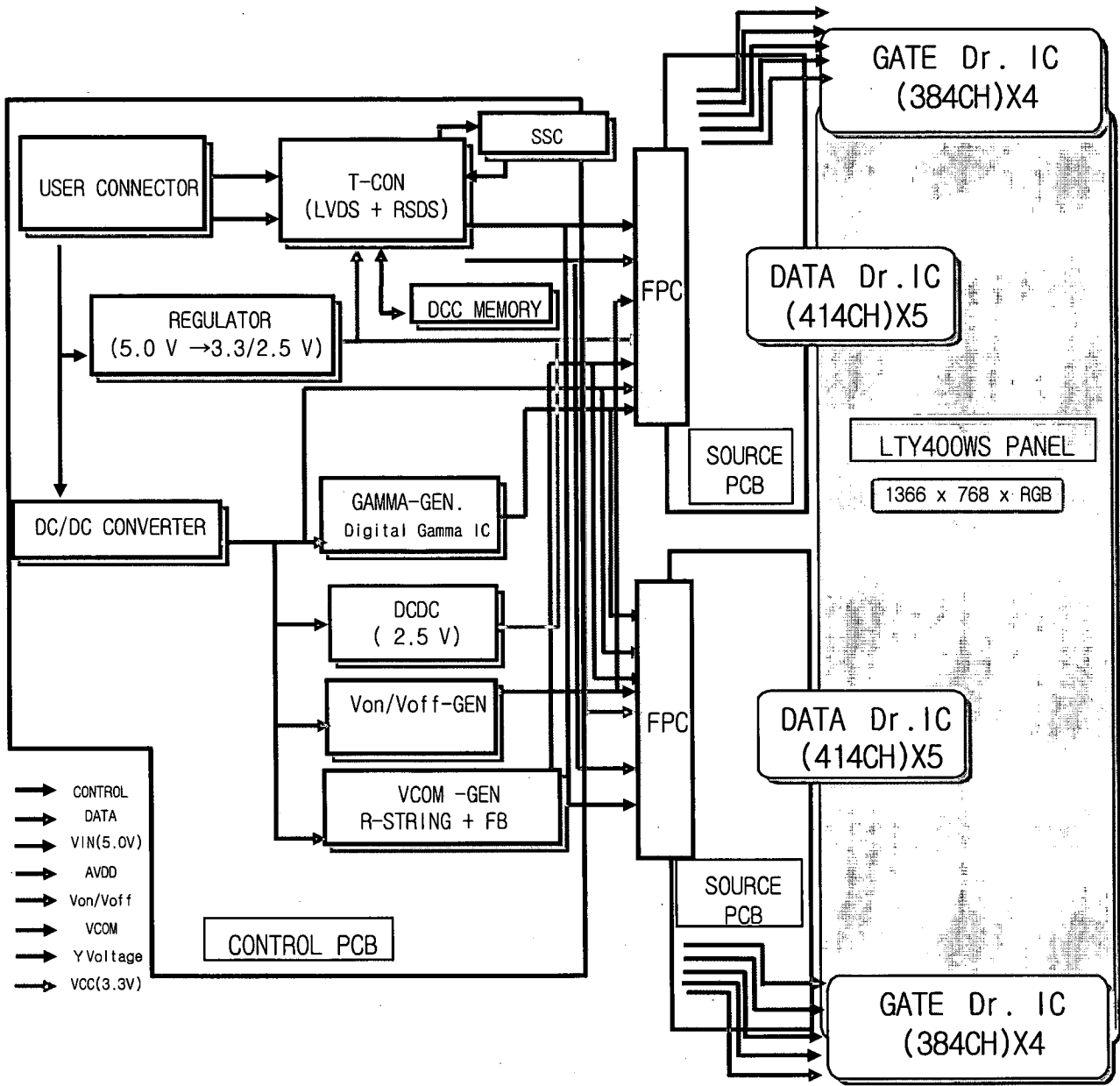

5. Input Terminal Pin Assignment

5.1. Input Signal & Power

Connector : C2775-FI-R14S-HF (JAE)

PIN No.	Description	PIN No.	Description
1	DC Power Supply	21	LVDS Clock+
2	DC Power Supply	22	Ground
3	DC Power Supply	23	RxIN3-
4	DC Power Supply	24	RxIN3+
5	DC Power Supply	25	GND
6	Ground	26	No Connect (Open)
7	Ground	27	No Connect (Open)
8	Ground	28	Ground
9	Ground	29	I2C Clock
10	Ground	30	I2C Data
11	RxIN0-	31	No Connect (Open)
12	RxIN0+	32	Bus Release
13	Ground	33	ACC On/OFF
14	RxIN1-	34	DCC SEL 0 [no use]
15	RxIN1+	35	DCC SEL 1 [no use]
16	Ground	36	DCC LUT SEL 0
17	RxIN2-	37	DCC LUT SEL 1
18	RxIN2+	38	DCC LUT SEL 2
19	Ground	39	SEC Internal Use Only (Open)
20	LVDS Clock-	40	SEC Internal Use Only (Open)
		41	SEC Internal Use Only (Open)

■ BBC SEL - HIGH : ON LOW/OPEN : OFF

■ ACC SEL - HIGH : ACC OFF LOW/OPEN : ACC ON

■ B-INT : I2C BUS RELEASE

L/OPEN	SDA/SCL LINE BECOME HI-Z
H	USER CAN ACCESS EEPROM

■ DCC SELECTION

		DCC SELECT BIT 0	
		0 or Open	1
SELECT BIT 1	0 or Open	DCC2 ON	DCC1 ON
	1	DCC OFF	DCC OFF

■ DCC Look Up Table Selection

Pin N.O.	38	37	36	Description (Based on DCC On)
Select bit	0	0	0	50%
	0	0	1	37.5%
	0	1	0	75%
	0	1	1	56%
	1 or Open	0	0	100%
	1 or Open	0	1	75%
	1 or Open	1	0	0%
	1 or Open	1	1	0%

Note(1) Pin number starts from Right side

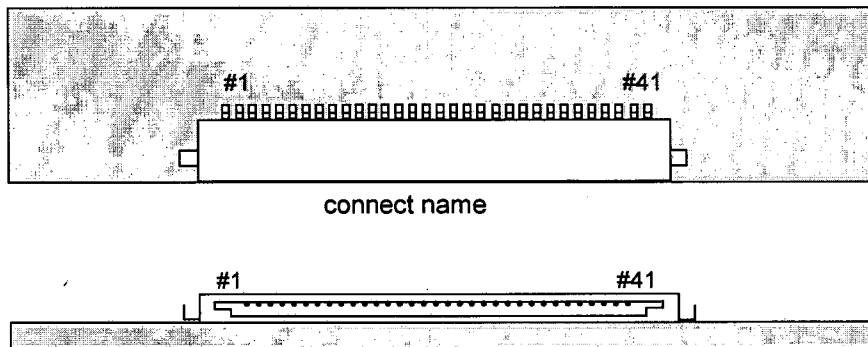
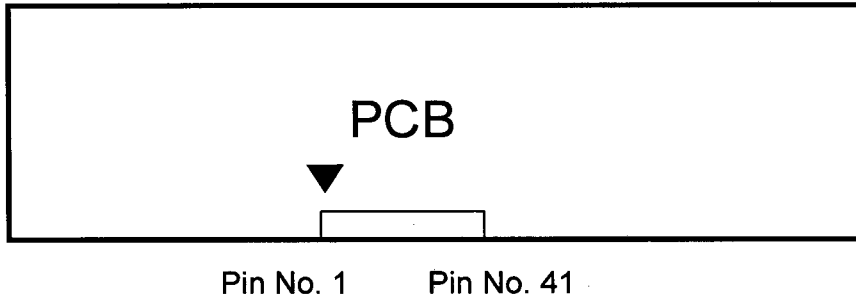

Fig. Connector diagram

- a. All GND pins should be connected together and also be connected to the LCD's metal chassis.
- b. All power input pins should be connected together.
- c. All NC pins should be separated from other signal or power.

5.2. Inverter Input Pin Configuration

Connector : S14B-PH-SM3-TB(JST)

Pin No.	Pin Configuration(FUNCTION)
1	17.5V
2	17.5 V
3	17.5 V
4	17.5 V
5	17.5 V
6	GND
7	GND
8	GND
9	GND
10	GND
11	No Connection
12	Backlight On /Off
13	Dimming Control
14	GND

5.3. Inverter Input Power Sequence & Specification

Items	Symbol	Conditions	Specifications			Unit	Note
			Min.	Typ.	Max.		
Input Voltage	V_{in}	-	16.0	17.5	19.0	V	$T_a=25\pm 2\text{ }^\circ\text{C}$
Input Current	I_{SAT}	$V_{in}=17.5\text{ V}$ $V_{dim}=2.0\text{ V}$	-	8.5	-		1 hour aging
Lamp Current	I_o	$V_{dim}=2.0\text{ V}$	6.55	7.55	8.05	mArms	Hot Side
Frequency	F_{LAMP}	$V_{in}=17.5\text{ V}$	55	60	65	kHz	-
Backlight On/Off	ON	$V_{in}=17.5\text{ V}$	2.0	-	5.25	V	-
	OFF	$V_{in}=17.5\text{ V}$	-0.3	-	1.0		
Dimming Control	V_{DIM}	Max Lum	2.8	-	-	V	-
		Min. Lum	-	-	0		

5.4 LVDS Interface
 - LVDS Receiver : Tcon (merged)

	LVDS pin	JEIDA -DATA
TxOUT/RxIN0	TxIN/RxOUT0	R2
	TxIN/RxOUT1	R3
	TxIN/RxOUT2	R4
	TxIN/RxOUT3	R5
	TxIN/RxOUT4	R6
	TxIN/RxOUT6	R7
	TxIN/RxOUT7	G2
TxOUT/RxIN1	TxIN/RxOUT8	G3
	TxIN/RxOUT9	G4
	TxIN/RxOUT12	G5
	TxIN/RxOUT13	G6
	TxIN/RxOUT14	G7
	TxIN/RxOUT15	B2
	TxIN/RxOUT18	B3
TxOUT/RxIN2	TxIN/RxOUT19	B4
	TxIN/RxOUT20	B5
	TxIN/RxOUT21	B6
	TxIN/RxOUT22	B7
	TxIN/RxOUT24	HSYNC
	TxIN/RxOUT25	VSYNC
	TxIN/RxOUT26	DEN
TxOUT/RxIN3	TxIN/RxOUT27	R0
	TxIN/RxOUT5	R1
	TxIN/RxOUT10	G0
	TxIN/RxOUT11	G1
	TxIN/RxOUT16	B0
	TxIN/RxOUT17	B1
	TxIN/RxOUT23	RESERVED

5.5 Input Signals, Basic Display Colors and Gray Scale of Each Color

COLOR	DISPLAY (8bit)	DATA SIGNAL																					GRAY SCALE LEVEL				
		RED							GREEN							BLUE											
		R0	R1	R2	R3	R4	R5	R6	R7	G0	G1	G2	G3	G4	G5	G6	G7	B0	B1	B2	B3	B4		B5	B6	B7	
BASIC COLOR	BLACK	0	0	0	0	0	0	0	0	0	0	0	0	0	0	0	0	0	0	0	0	0	0	0	0	-	
	BLUE	0	0	0	0	0	0	0	0	0	0	0	0	0	0	0	0	0	1	1	1	1	1	1	1	1	-
	GREEN	0	0	0	0	0	0	0	0	1	1	1	1	1	1	1	1	0	0	0	0	0	0	0	0	-	
	CYAN	0	0	0	0	0	0	0	0	1	1	1	1	1	1	1	1	1	1	1	1	1	1	1	1	-	
	RED	1	1	1	1	1	1	1	1	0	0	0	0	0	0	0	0	0	0	0	0	0	0	0	0	-	
	MAGENTA	1	1	1	1	1	1	1	1	0	0	0	0	0	0	0	0	1	1	1	1	1	1	1	1	-	
	YELLOW	1	1	1	1	1	1	1	1	1	1	1	1	1	1	1	1	0	0	0	0	0	0	0	0	-	
	WHITE	1	1	1	1	1	1	1	1	1	1	1	1	1	1	1	1	1	1	1	1	1	1	1	1	-	
GRAY SCALE OF RED	BLACK	0	0	0	0	0	0	0	0	0	0	0	0	0	0	0	0	0	0	0	0	0	0	0	R0		
	DARK ↑	1	0	0	0	0	0	0	0	0	0	0	0	0	0	0	0	0	0	0	0	0	0	0	R1		
		0	1	0	0	0	0	0	0	0	0	0	0	0	0	0	0	0	0	0	0	0	0	0	R2		
		: : : : : :	: : : : : :	: : : : : :	: : : : : :	: : : : : :	: : : : : :	: : : : : :	: : : : : :	: : : : : :	: : : : : :	: : : : : :	: : : : : :	: : : : : :	: : : : : :	: : : : : :	: : : : : :	: : : : : :	: : : : : :	: : : : : :	: : : : : :	: : : : : :	: : : : : :	: : : : : :	R3~R252		
	LIGHT ↓	1	0	1	1	1	1	1	1	0	0	0	0	0	0	0	0	0	0	0	0	0	0	0	R252		
		0	1	1	1	1	1	1	1	0	0	0	0	0	0	0	0	0	0	0	0	0	0	0	R252		
	RED	1	1	1	1	1	1	1	1	0	0	0	0	0	0	0	0	0	0	0	0	0	0	0	R252		
GRAY SCALE OF GREEN	BLACK	0	0	0	0	0	0	0	0	0	0	0	0	0	0	0	0	0	0	0	0	0	0	0	G0		
	DARK ↑	0	0	0	0	0	0	0	0	1	0	0	0	0	0	0	0	0	0	0	0	0	0	0	G1		
		0	0	0	0	0	0	0	0	0	1	0	0	0	0	0	0	0	0	0	0	0	0	0	G2		
		: : : : : :	: : : : : :	: : : : : :	: : : : : :	: : : : : :	: : : : : :	: : : : : :	: : : : : :	: : : : : :	: : : : : :	: : : : : :	: : : : : :	: : : : : :	: : : : : :	: : : : : :	: : : : : :	: : : : : :	: : : : : :	: : : : : :	: : : : : :	: : : : : :	: : : : : :	: : : : : :	G3~G252		
	LIGHT ↓	0	0	0	0	0	0	0	0	1	0	1	1	1	1	1	1	0	0	0	0	0	0	0	G252		
		0	0	0	0	0	0	0	0	0	1	1	1	1	1	1	1	0	0	0	0	0	0	0	G252		
	GREEN	0	0	0	0	0	0	0	0	1	1	1	1	1	1	1	1	0	0	0	0	0	0	0	G252		
GRAY SCALE OF BLUE	BLACK	0	0	0	0	0	0	0	0	0	0	0	0	0	0	0	0	0	0	0	0	0	0	0	B0		
	DARK ↑	0	0	0	0	0	0	0	0	0	0	0	0	0	0	0	0	1	0	0	0	0	0	0	B1		
		0	0	0	0	0	0	0	0	0	0	0	0	0	0	0	0	0	1	0	0	0	0	0	B2		
		: : : : : :	: : : : : :	: : : : : :	: : : : : :	: : : : : :	: : : : : :	: : : : : :	: : : : : :	: : : : : :	: : : : : :	: : : : : :	: : : : : :	: : : : : :	: : : : : :	: : : : : :	: : : : : :	: : : : : :	: : : : : :	: : : : : :	: : : : : :	: : : : : :	: : : : : :	: : : : : :	B3~B252		
	LIGHT ↓	0	0	0	0	0	0	0	0	0	0	0	0	0	0	0	0	1	0	1	1	1	1	1	B252		
		0	0	0	0	0	0	0	0	0	0	0	0	0	0	0	0	0	1	1	1	1	1	1	B252		
BLUE	0	0	0	0	0	0	0	0	0	0	0	0	0	0	0	0	1	1	1	1	1	1	1	B252			

Note) Definition of Gray :
 Rn : Red Gray, Gn : Green Gray, Bn : Blue Gray (n = Gray level)
 Input Signal : 0 = Low level voltage, 1 = High level voltage

6. Interface Timing

6.1 Timing Parameters (DE only mode)

SIGNAL	ITEM	SYMBOL	MIN.	TYP.	MAX.	Unit	NOTE
Clock	Frequency	$1/T_C$	60	80	82	MHz	-
Hsync		F_H	43	48	53	KHz	-
Vsync		F_V	47	60	66	Hz	-
Vertical Display Term	Active Display Period	T_{VD}	-	768	-	lines	-
	Vertical Total	T_{VB}	785	810	1200	Lines	-
Horizontal Display Term	Active Display Period	T_{HD}	-	1366	-	clocks	-
	Horizontal Total	T_H	1556	1648	1700	clocks	-

Note) This product is DE only mode. The input of Hsync & Vsync signal does not have an effect on normal operation.

(1) Test Point : TTL control signal and CLK at LVDS Tx input terminal in system

(2) Internal $V_{DD} = 3.3V$

6.2 Timing diagrams of interface signal (DE only mode)

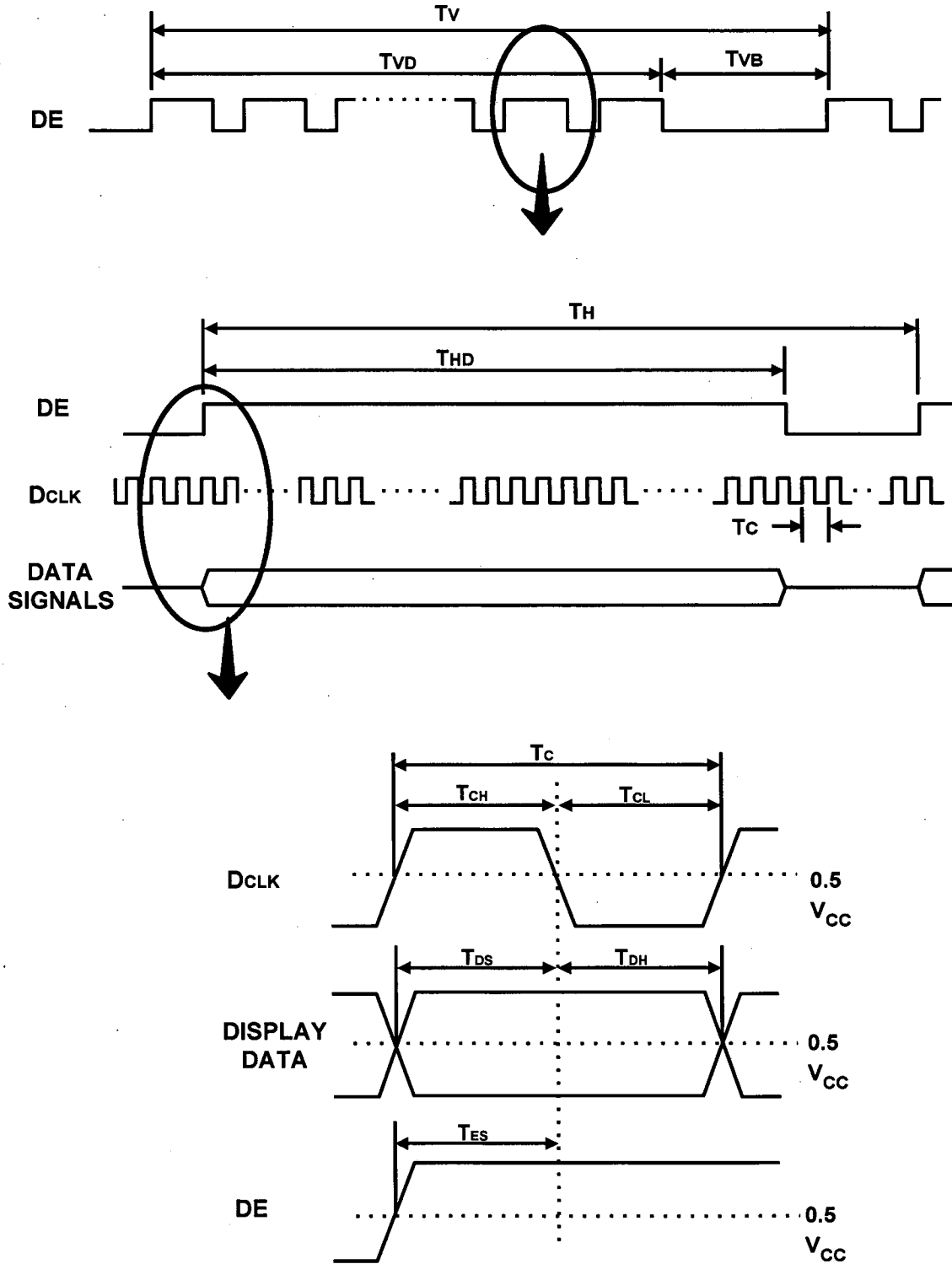

6.3 Power ON/OFF Sequence

To prevent a latch-up or DC operation of the LCD Module, the power on/off sequence should be as the diagram below.

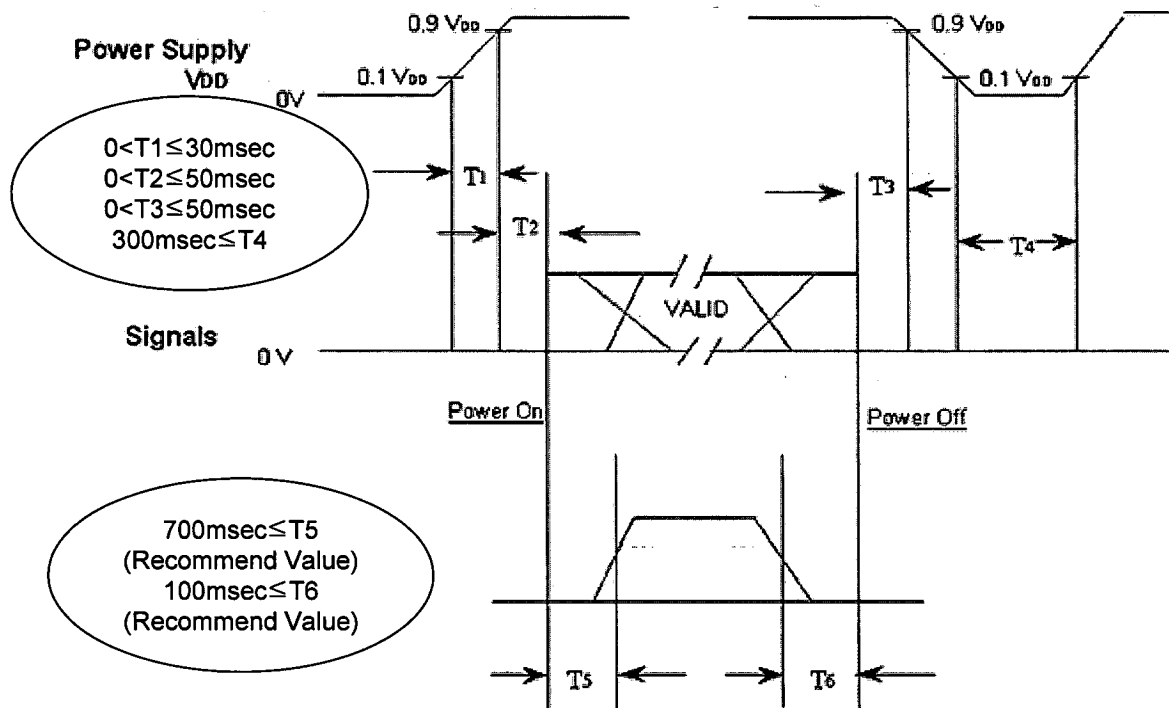

- T_1 : V_{DD} rising time from 10% to 90%
- T_2 : The time from V_{DD} to valid data at power ON.
- T_3 : The time from valid data off to V_{DD} off at power Off.
- T_4 : V_{DD} off time for Windows restart
- T_5 : The time from valid data to B/L enable at power ON.
- T_6 : The time from valid data off to B/L disable at power Off.

- The supply voltage of the external system for the Module input should be the same as the definition of V_{DD} .
- Apply the lamp voltage within the LCD operation range. When the back light turns on before the LCD operation or the LCD turns off before the back light turns off, the display may momentarily show abnormal screen.
- In case of V_{DD} = off level, please keep the level of input signals low or keep a high impedance.
- T_4 should be measured after the Module has been fully discharged between power off and on period.
- Interface signal should not be kept at high impedance when the power is on.

7. Outline dimension (Front view)

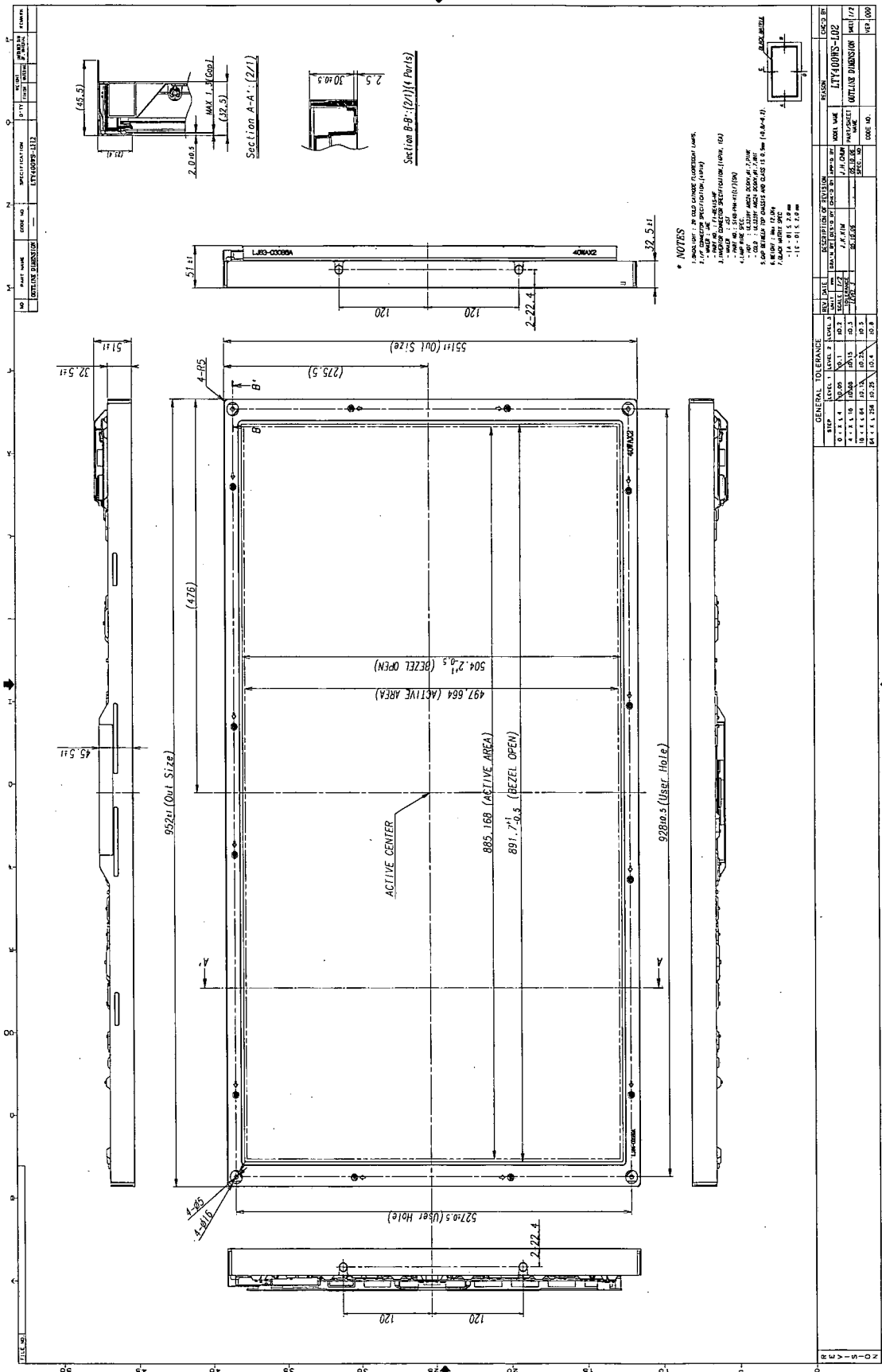

- NOTES**
1. ALL DIMENSIONS ARE IN MILLIMETERS UNLESS OTHERWISE SPECIFIED.
 2. DIMENSIONS IN PARENTHESES ARE FOR REFERENCE ONLY.
 3. DIMENSIONS IN SQUARE BRACKETS ARE FOR REFERENCE ONLY.
 4. DIMENSIONS IN BRACKETS ARE FOR REFERENCE ONLY.
 5. DIMENSIONS IN BRACKETS ARE FOR REFERENCE ONLY.
 6. DIMENSIONS IN BRACKETS ARE FOR REFERENCE ONLY.
 7. DIMENSIONS IN BRACKETS ARE FOR REFERENCE ONLY.
 8. DIMENSIONS IN BRACKETS ARE FOR REFERENCE ONLY.
 9. DIMENSIONS IN BRACKETS ARE FOR REFERENCE ONLY.
 10. DIMENSIONS IN BRACKETS ARE FOR REFERENCE ONLY.

GENERAL INFORMATION		REVISION		DESCRIPTION OF REVISION		DATE	
NO.	REV.	NO.	REV.	NO.	REV.	NO.	REV.
0	1	1	1	1	1	1	1
1	1	1	1	1	1	1	1
2	1	1	1	1	1	1	1
3	1	1	1	1	1	1	1
4	1	1	1	1	1	1	1
5	1	1	1	1	1	1	1
6	1	1	1	1	1	1	1
7	1	1	1	1	1	1	1
8	1	1	1	1	1	1	1
9	1	1	1	1	1	1	1
10	1	1	1	1	1	1	1

8. EMI Specification

: -3dB at CISPR22 Class B [Samsung Standard]

9. UL Approval

MODEL	LTY[Z]400WS-L02	Doc. No	05-006-S-070109	Page	22 / 28
-------	-----------------	---------	-----------------	------	---------

10. Reliability Test

Item	Test condition	Quantity
Temperature Step Stress	0 ~ 50℃, 10Cycle determination	4EA
HTOL	50℃, 1000hr (500hr determination)	8EA
LTOL	0℃, 1000hr (500hr determination)	4EA
RTOL	20℃, continue ~	4EA
HTS	70℃, 1000hr (500hr determination)	4EA
LTS	-30℃, 1000hr (500hr determination)	4EA
THB	40℃ / 95%RH, 1000hr (500hr determination)	4EA
WHTS	60℃ / 75%RH, 1000hr (500hr determination)	4EA
T/C	-20℃ ~ 60℃, 200cycle (100cycle determination)	4EA
ESD (non-operation)	± 10 kV, 200pF/100Ω, 9Point, 3times/Point	3EA
ESD(operation)	Samsung condition : contact : ± 8 kV, 150pF/330Ω, 100Point, 1 time/Point non-contact : ± 15 kV, 150pF/330Ω, 100Point, 1 time/Point Sony condition : contact : ± 8 kV, 200pF/100Ω, 100Point, 1 time/Point non-contact : ± 15 kV, 200pF/100Ω, 100Point, 1 time/Point	3EA
Input Con. ESD	contact : ± 2kV, 200pF/100, Input Con. Pin, 3 times/Pin	3EA
POWER ON/OFF	30sec (on) / 30sec(off) : 12,000 times	4EA
Vibration	10~300Hz/1.5G/10minSR, XYZ, 30min/axis	3EA
Shock	SEC condition : 50G, 11msec, ±XYZ 1time/axis	3EA
PALLET Vibration	1.146 Grms, 2~200Hz, Random, Z axis 1Hr	1PALLET(30EA)
PALLET Drop	20cm, Bottom, Front, Real 1times	1PALLET(30EA)

[Result Evaluation Criteria]

Under the display quality test conditions with normal operation state, these shall be no change which may affect practical display function.

HTOL/ LTOL : High/Low Temperature Operating Life,
 THB : Temperature Humidity Bias
 HTS/LTS : High/Low Temperature Storage
 WHTS : Wet High Temperature Storage

11. PACKING

11.1 CARTON (Internal Package)

(1) Packing Form

Corrugated fiberboard box and corrugated cardboard as shock absorber

(2) Packing Method

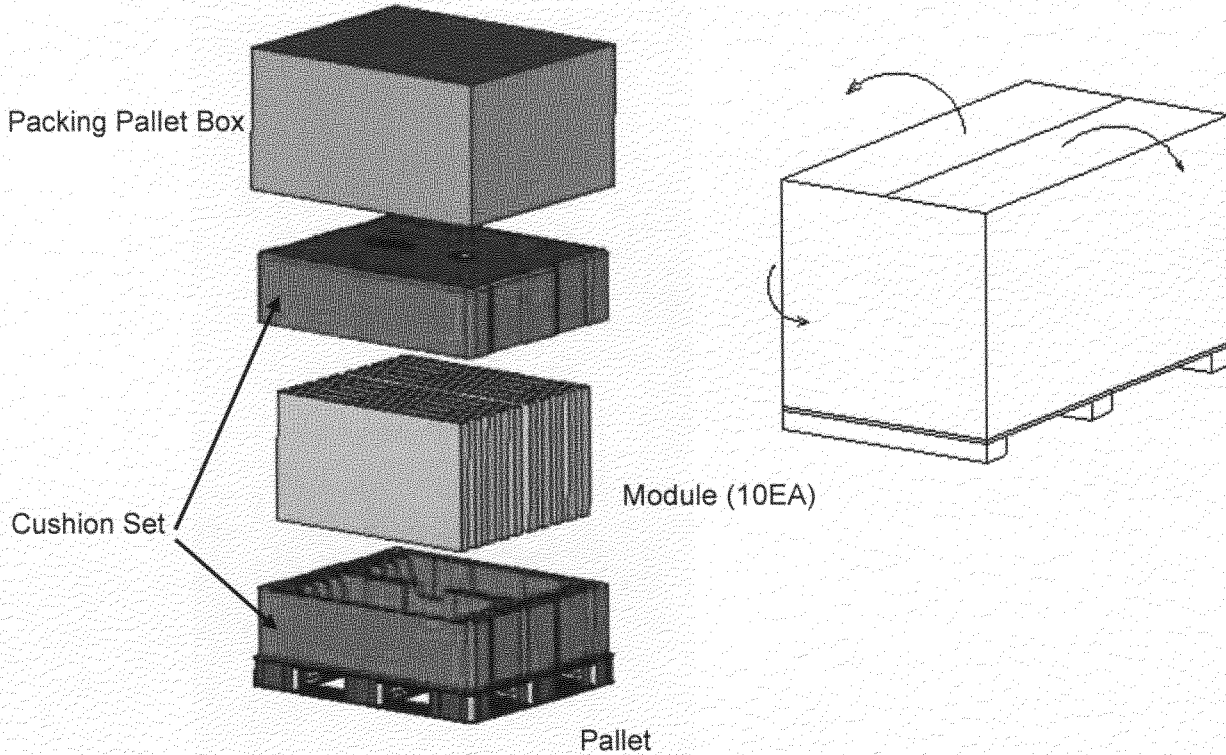

11.2 Packing Specification

Item	Specification	Remark
LCD Packing	10 ea / (Packing-Pallet Box)	1. 120Kg/LCD(10ea) 2. 7kg/Cushion Set(2ea) 3. 6.7kg/Packing-Pallet Box(1ea) 4. Cushion Material : EPS 5. Packing Pallet Box Material : DW4
Pallet	1 Box / Pallet	Pallet weight : 8.0kg
Packing Direction	Vertical	-
Total Pallet Size	H x V x height	1150mm(H) x 985mm(V) x 609mm(Height)
Total Pallet Weight	141.7 kg	Pallet(8.0kg) + Module(12 x 10 = 120kg) + Cushion(7kg) + Pallet-BOX(6.7kg)

12. MARKING & OTHERS

A nameplate bearing followed by is affixed to a shipped product at the specified location on each product.

- (1) Parts number : LTY[Z]400WS-L02-XXXX
- (2) Revision: One letters
- (3) Lot number : X X X X XXX XX X

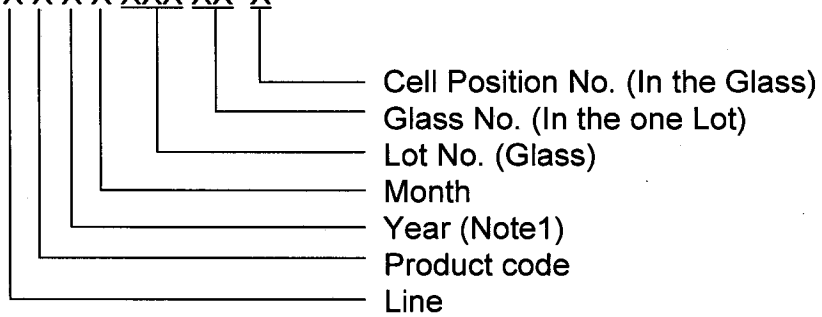

(4) Nameplate Indication

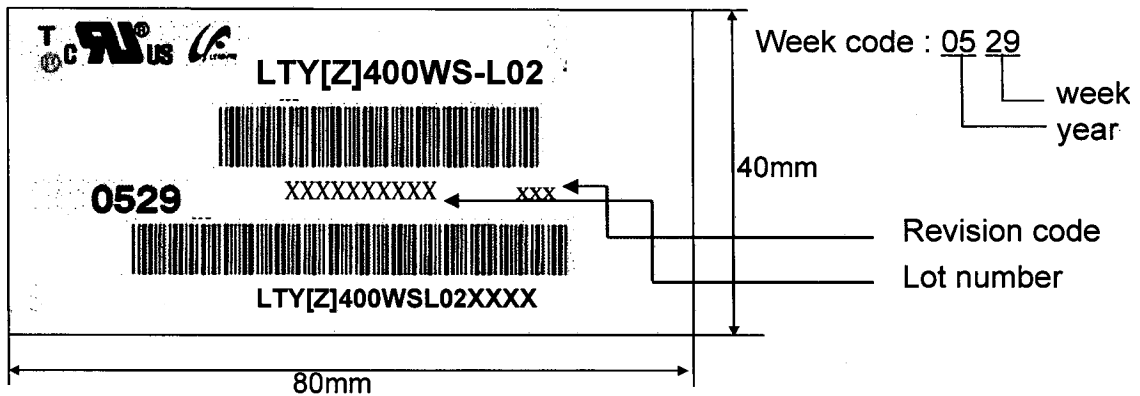

(5) Packing box attach

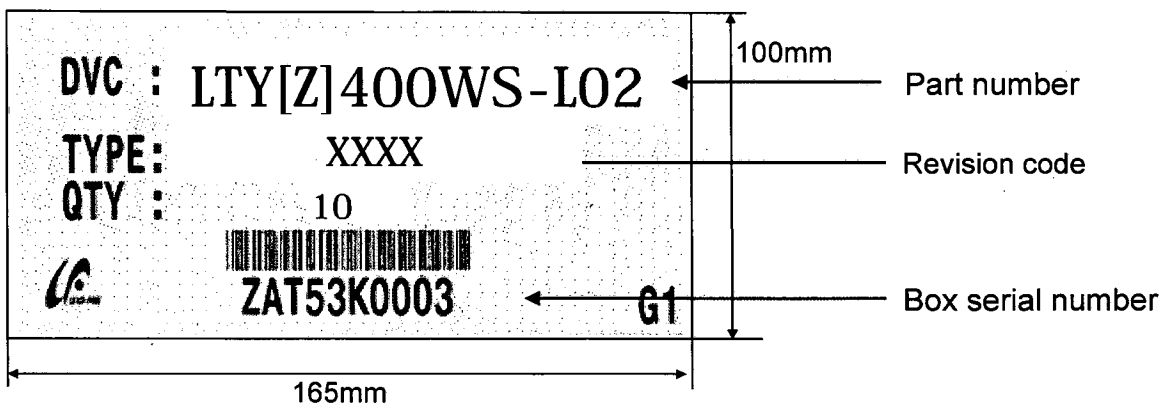

(6) Others

- 1. After service part

Lamps cannot be replaced because of the narrow bezel structure.

MODEL	LTY[Z]400WS-L02	Doc. No	05-006-S-070109	Page	25 / 28
-------	-----------------	---------	-----------------	------	---------

13. General Precautions

13.1 Handling

- (a) When the Module is assembled, it should be attached to the system firmly using all mounting holes. Be careful not to twist and bend the Module.
- (b) Because the inverter use high voltage, it should be disconnected from power before it is assembled or disassembled.
- (c) Refrain from strong mechanical shock and / or any force to the Module. In addition to damage, this may cause improper operation or damage to the Module and CCFT back light.
- (d) Note that polarizers are very fragile and could be damage easily. Do not press or scratch the surface harder than a HB pencil lead.
- (e) Wipe off water droplets or oil immediately. If you leave the droplets for a long time, staining or discoloration may occur.
- (f) If the surface of the polarizer is dirty, clean it using absorbent cotton or soft cloth.
- (g) Desirable cleaners are water, IPA(Isopropyl Alcohol) or Hexane. Do not use Ketone type materials(ex. Acetone), Ethyl alcohol, Toluene, Ethyl acid or Methyl chloride. It might permanent damage to the polarizer due to chemical reaction.
- (h) If the liquid crystal material leaks from the panel, it should be kept away from the eyes or mouth . In case of contact with hands, legs or clothes, it must be washed away with soap thoroughly.
- (i) Protect the Module from static, or the CMOS Gate Array IC would be damaged.
- (j) Use finger-stalls with soft gloves in order to keep display clean during the incoming inspection and assembly process.
- (k) Do not disassemble the Module.
- (l) Do not pull or fold the lamp wire.
- (m) Do not adjust the variable resistor located on the Module.
- (n) Protection film for polarizer on the Module should be slowly peeled off just before use so that the electrostatic charge can be minimized.
- (o) Pins of I/F connector should not be touched directly with bare hands.

13.2 Storage

- (a) Do not leave the Module in high temperature, and high humidity for a long time. It is highly recommended to store the Module with temperature from 0 to 35 °C and relative humidity of less than 70%.
- (b) Do not store the TFT-LCD Module in direct sunlight.
- (c) The Module should be stored in a dark place. It is prohibited to apply sunlight or fluorescent light in storing.

13.3 Operation

- (a) No Connection or disconnect the Module in the "Power On" condition.
- (b) Power supply should always be turned on/off by the "Power on/off sequence"
- (c) Module has high frequency circuits. Sufficient suppression to the electromagnetic interference should be done by system manufacturers. Grounding and shielding methods may be important to minimize the interference.
- (d) The cable between the back light connector and its inverter power supply should be connected directly with a minimized length. A longer cable between the back light and the inverter may cause lower luminance of lamp(CCFT) and may require higher startup voltage(Vs).

13.4 Operation Condition Guide

- (a) The LCD product should be operated under normal conditions.
Normal condition is defined as below;
 - Temperature : $20 \pm 15^{\circ}\text{C}$
 - Humidity : $55 \pm 20\%$
 - Display pattern : continually changing pattern (Not stationary)
- (b) If the product will be used in extreme conditions such as high temperature, humidity, display patterns or operation time etc., It is strongly recommended to contact SEC for Application engineering advice. Otherwise, its reliability and function may not be guaranteed. Extreme conditions are commonly found at Airports, Transit Stations, Banks, Stock market, and Controlling systems.

MODEL	LTY[Z]400WS-L02	Doc. No	05-006-S-070109	Page	27 / 28
-------	-----------------	---------	-----------------	------	---------

13.5 Others

- (a) Ultra-violet ray filter is necessary for outdoor operation.
- (b) Avoid condensation of water. It may result in improper operation or disconnection of electrode.
- (c) Do not exceed the absolute maximum rating value. (supply voltage variation, input voltage variation, variation in part contents and environmental temperature, and so on)
Otherwise the Module may be damaged.
- (d) If the Module keeps displaying the same pattern for a long period of time, the image may be "sticked" to the screen.
To avoid image sticking, it is recommended to use a screen saver.
- (e) This Module has its circuitry PCB's on the rear side and should be handled carefully in order not to be stressed.
- (f) Please contact SEC in advance when you display the same pattern for a long time.