



LIGITEK

LIGITEK ELECTRONICS CO.,LTD.  
Property of Ligitek Only

[www.DataSheet4U.com](http://www.DataSheet4U.com)

PLCC-4 TOPLED



Lead-Free Parts

**LUROS9553-4/TR1**

**DATA SHEET**

DOC. NO : QW0905-LUROS9553-4/TR1

REV : A

DATE : 10 - Sep. - 2008



### Features

- \*package : 12mm tape on 7" diameter reels.
- \*feature of the device: more light due to higher optical efficiency,higher ambient temperature at the same current possible compared to TOPLED
- \*assembly methods: suitable for all SMT assembly methods
- \*ESD-withstand voltage: up to 2kv acc. to JESD22-A114-B

### Applications

- \*traffic lights
- \*backlighting(LCD,switches,keys,displays,illuminated advertising)
- \*interior and exterior automotive lighting(e.g.dashboard backlighting,turn signal lamps,sidemarkers, brake lights)
- \*substitution of micro incandescent lamps
- \*marker lights(e.g.exit ways,etc.)
- \*signal and symbol luminaire

### Package Dimensions

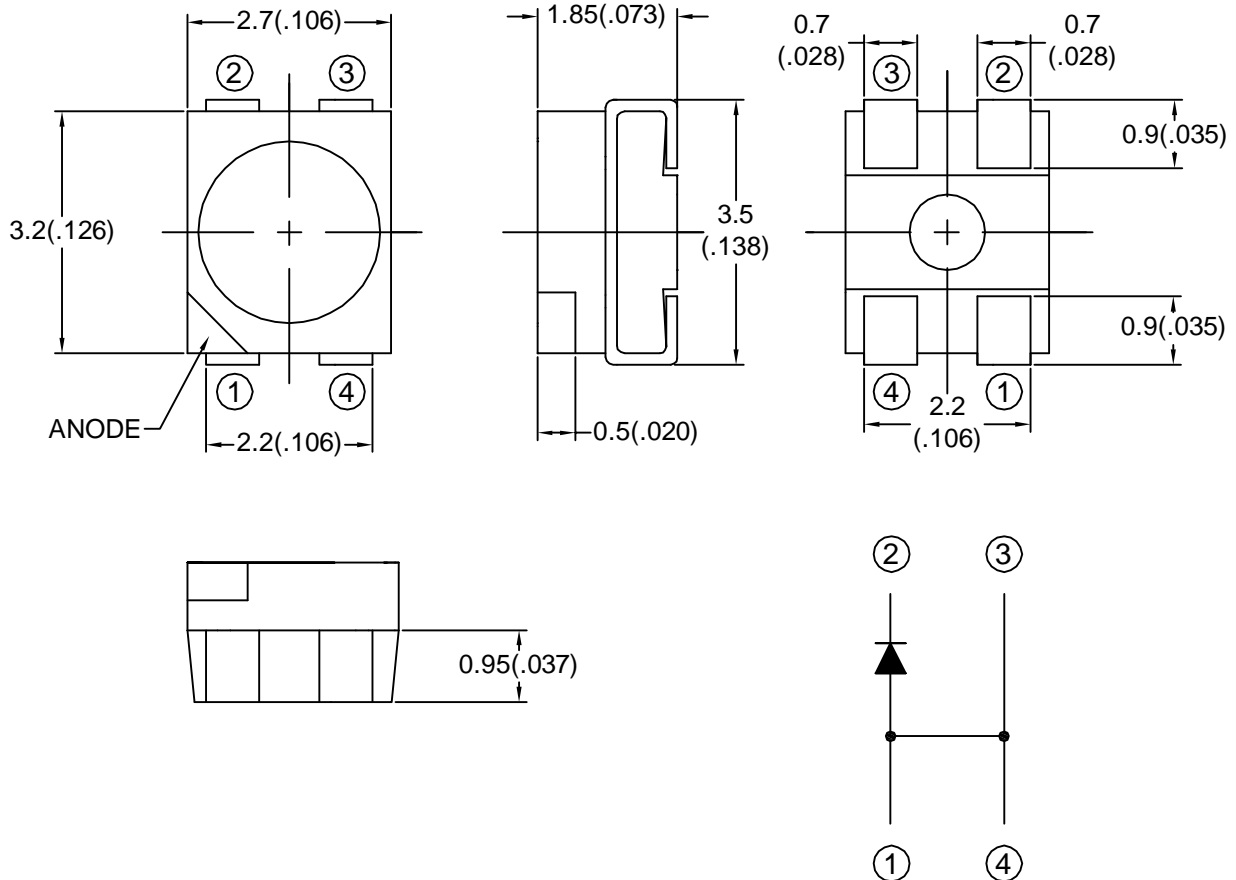

Note : 1.All dimension are in millimeter tolerance is  $\pm 0.2\text{mm}$  unless otherwise noted.  
2.Specifications are subject to change without notice.



Absolute Maximum Ratings at Ta=25 °C

Parameter	Symbol	Ratings	UNIT
		UROS	
Forward Current	IF	70	mA
Peak Forward Current Duty 1/10@10KHz	IFP	100	mA
Power Dissipation	PD	200	mW
Reverse Current @5V	Ir	10	μA
Electrostatic Discharge( * )	ESD	2000	V
Operating Temperature	Topr	-40 ~ +100	°C
Storage Temperature	Tstg	-40 ~ +100	°C

\* Static Electricity or power surge will damage the LED. Use of a conductive wrist band or anti-electrostatic glove is recommended when handling these LED. All devices, equipment and machinery must be properly grounded.

IR-Reflow Profile for lead free soldering(Acc.to J-STD-020B)

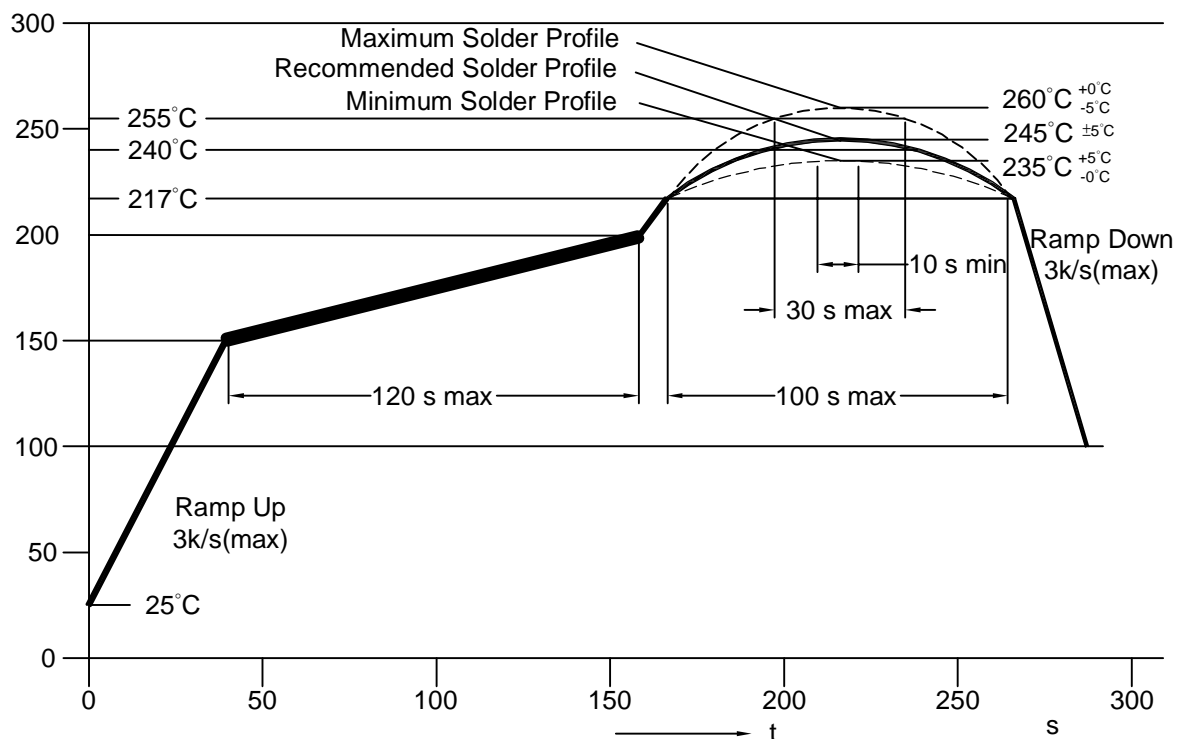



### Typical Electrical & Optical Characteristics (Ta=25 °C)

PART NO	MATERIAL	COLOR		Dominant wave length $\lambda$ Dnm	Spectral halfwidth $\Delta \lambda$ nm	Forward voltage @50mA(V)		Luminous intensity @50mA(mcd)		Viewing angle $2\theta$ 1/2 (deg)
		Emitted	Lens			Min.	Max.	Min.	Typ.	
LUROS9553-4/TR1	InGaAIP	Red	Water Clear	625	30	1.5	2.6	500	1250	120

- Note :
- 1.The forward voltage data did not including  $\pm 0.1V$  testing tolerance.
  2. The luminous intensity data did not including  $\pm 15\%$  testing tolerance.

### Recommended Solder Pad useable for PLCC-4 TOPLED

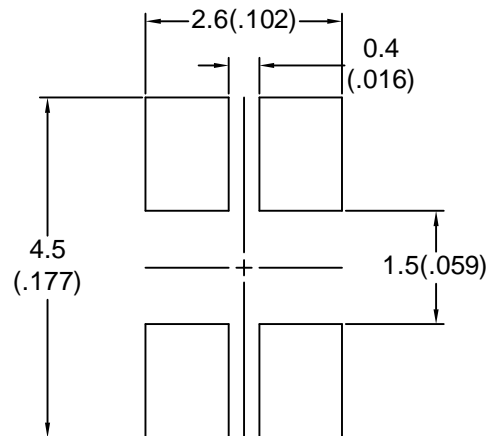



### Typical Electro-Optical Characteristics Curve

#### UROS CHIP

Fig.1 Forward current vs. Forward Voltage

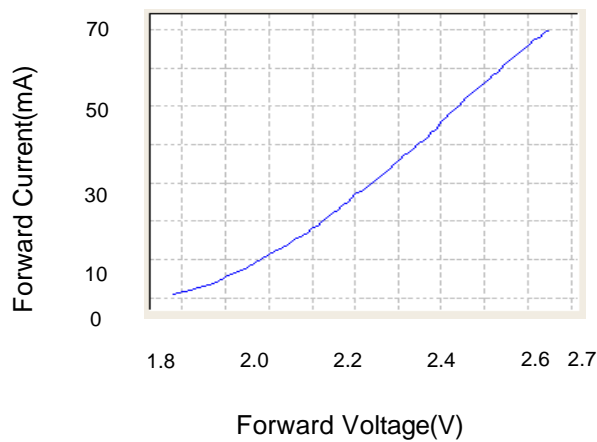

Fig.2 Relative Intensity vs. Forward Current

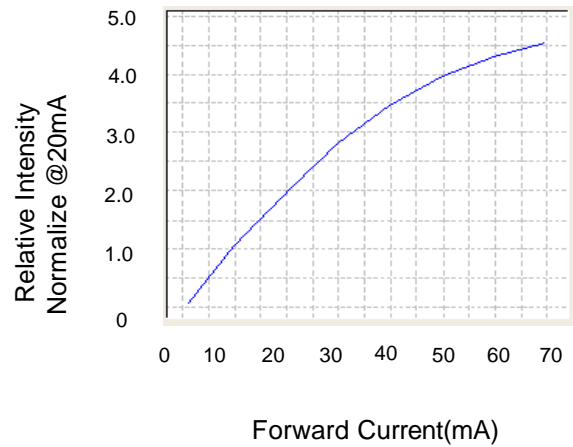

Fig.3 Forward Voltage vs. Temperature

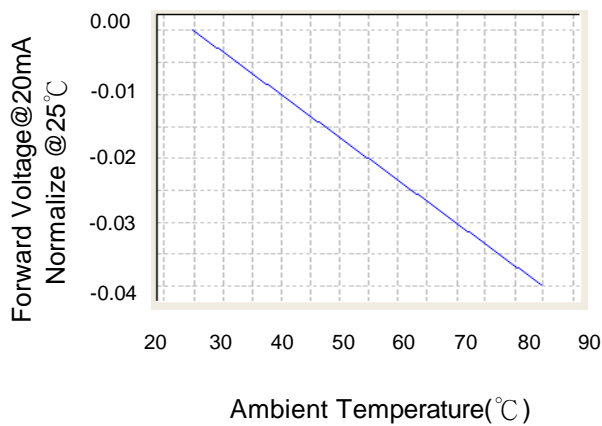

Fig.4 Relative Intensity vs. Temperature

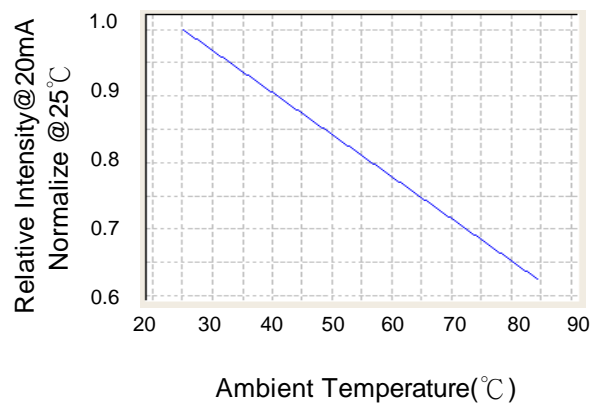

Fig.5 Relative Intensity vs. Wavelength

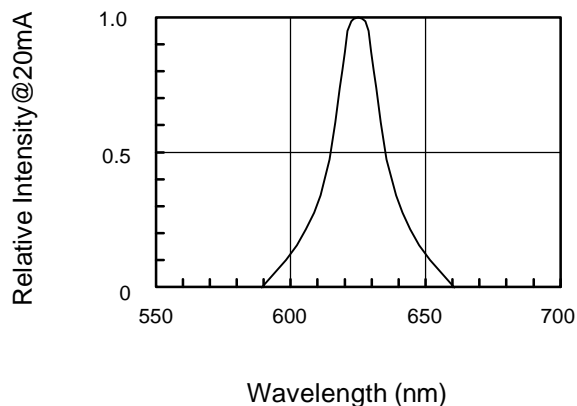
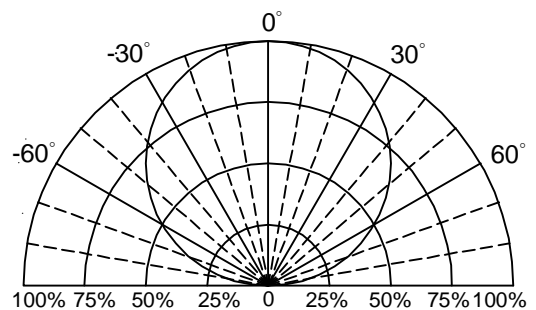

Fig.6 Directivity Radiation





LIGITEK

LIGITEK ELECTRONICS CO.,LTD.  
Property of Ligitek Only

www.DataSheet4U.com  
Page 5/7

PART NO. LUROS9553-4/TR1

### Reel Dimensions

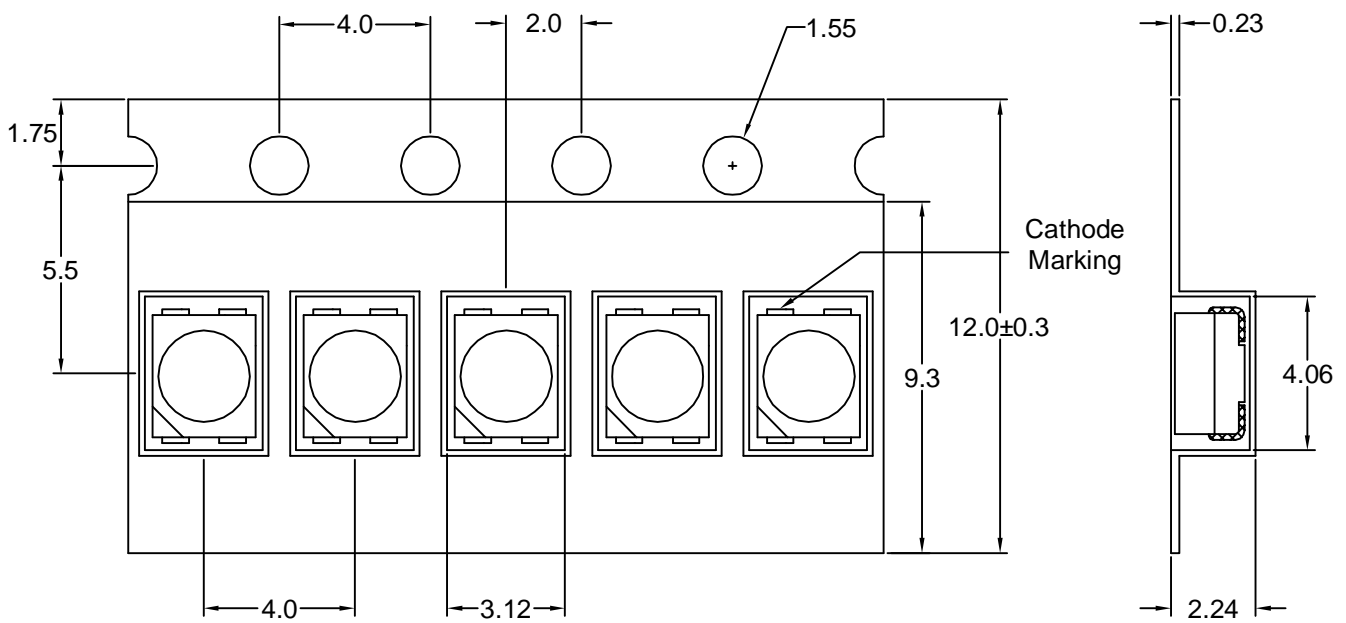
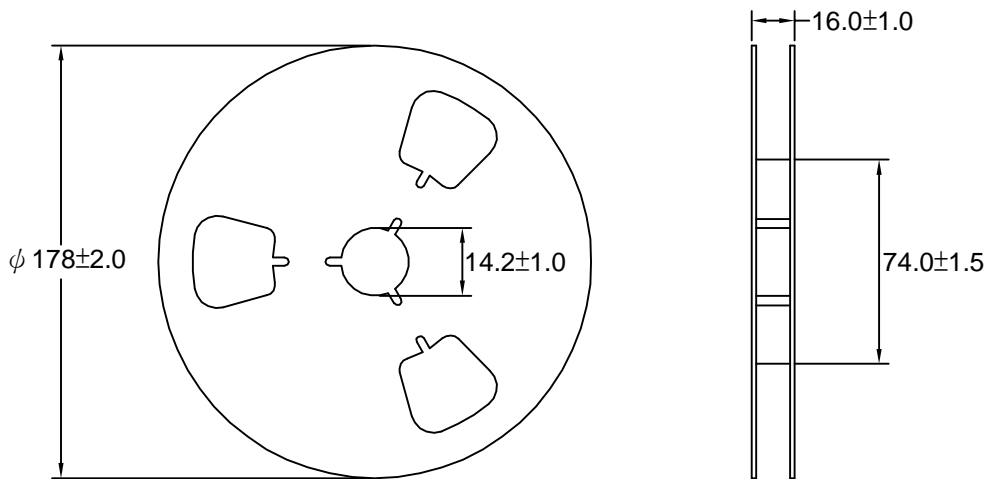

Part No.	Description	Quantity/Reel
LUROS9553-4/TR1	12.0mm tape,7"reel	1500 devices



## Drive Method

An LED is a current-operated device. In order to ensure intensity uniformity on multiple LEDs connected in parallel in an application, it is recommended that a current limiting resistor be incorporated in the drive circuit, in series with each LED as shown in Circuit A below

Circuit model A

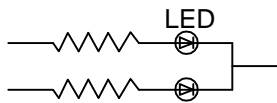

Circuit model B

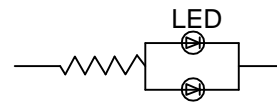

(A) Recommended circuit.

(B) The difference of brightness between LED could be found due to the VF-IF characteristics of LED.

### Cleaning:

Use alcohol-based cleaning solvents such as isopropyl alcohol to clean the LED if necessary

### ESD(Electrostatic Discharge):

Static Electricity or power surge will damage the LED. Use of a conductive wrist band or anti-electrosatic glove is recommended when handing these LED. All devices, equipment and machinery must be properly grounded.



Reliability Test:

Classification	Test Item	Test Condition	Reference Standard
Endurance Test	Operating Life Test	1.Ta=Under Room Temperature As Per Data Sheet Maximum Rating. 2.If=50mA 3.t=1000 hrs (-24hrs, +72hrs)	MIL-STD-750D: 1026 MIL-STD-883D: 1005 JIS C 7021: B-1
	High Temperature Storage Test	1.Ta=100°C±5°C 2.t=1000 hrs (-24hrs, +72hrs)	MIL-STD-883D:1008 JIS C 7021: B-10
	Low Temperature Storage Test	1.Ta=-40°C±5°C 2.t=1000 hrs (-24hrs, +72hrs)	JIS C 7021: B-12
	High Temperature High Humidity Storage Test	1.Ta=65°C±5°C 2.RH=90%~95% 3.t=240hrs±2hrs	MIL-STD-202F:103B JIS C 7021: B-11
Environmental Test	Thermal Shock Test	1.Ta=105°C±5°C & -40°C±5°C (30min) (30min) 2.total 100 cycles	MIL-STD-202F: 107D MIL-STD-750D: 1051 MIL-STD-883D: 1011
	Solderability Test	1.T.Sol=235°C±5°C 2.Immersion time 2 ±0.5sec 3.Coverage ≥95% of the dipped surface	MIL-STD-202F: 208D MIL-STD-750D: 2026 MIL-STD-883D: 2003 IEC 68 Part 2-20 JIS C 7021: A-2
	Temperature Cycling	1.105°C ~ 25°C ~ -55°C ~ 25°C 30mins 5mins 30mins 5mins 2.10 Cycles	MIL-STD-202F: 107D MIL-STD-750D: 1051 MIL-STD-883D: 1010 JIS C 7021: A-4
	IR Reflow	Ramp-up rate(217°C to Peak) +3°C second max Temp. maintain at 175(±25)°C 180 seconds max Temp. maintain above 217°C 60-150 seconds Peak temperature range 260°C +5/-0°C Time within 5°C of actual Peak Temperature(tp) 10-30 seconds Ramp-down rate +6 °C/second max	MIL-STD-750D:2031.2 J-STD-020B