



SANYO Semiconductors

DATA SHEET

LV1605M — Monolithic Linear IC Analog Signal Processor for CD Players

Overview

The LV1605M implements the analog signal processing and servo control required by compact disc players, and, when combined with a CD DSP such as the LC78604E or LC78605E, can implement a CD player with a minimal parts count. The LV1605M also provides a gain switching pin to allow it to support playback of CD-RW discs.

Functions

IV amplifier, RF amplifier (with AGC and hold function on defect detection), APC, FE (with VCA), TE (with VCA and auto-balance), focus servo amplifier (with offset canceller and hold function on defect detection), tracking servo amplifier (with offset canceller and hold function on defect detection), spindle servo amplifier (with gain switching function and hold function on defect detection), sled servo amplifier (with on/off function and hold function on defect detection), focus detection (DRF and FZD), track detection (HFL and TES), defect detection, shock detection, and disc mode gain switching function.

Features

- The LV1605M provides the following automatic adjustment functions.
 - Focus offset, auto canceller: FE (pin 21)
 - Tracking offset, auto canceller: TE (pin 7)
 - E/F balance automatic adjustment
 - RF level AGC function
 - Tracking servo gain RF level following function
 - Focus servo gain RF level following function
- Focus search smoothing setting pin: FSC (pin 58)
- Focus search mode switching pin: FSS (pin 54)
- Play disc mode (normal or CD-RW) switching pin: RW (pin 44)

■ Any and all SANYO products described or contained herein do not have specifications that can handle applications that require extremely high levels of reliability, such as life-support systems, aircraft's control systems, or other applications whose failure can be reasonably expected to result in serious physical and/or material damage. Consult with your SANYO representative nearest you before using any SANYO products described or contained herein in such applications.

■ SANYO assumes no responsibility for equipment failures that result from using products at values that exceed, even momentarily, rated values (such as maximum ratings, operating condition ranges, or other parameters) listed in products specifications of any and all SANYO products described or contained herein.

SANYO Electric Co., Ltd. Semiconductor Company

TOKYO OFFICE Tokyo Bldg., 1-10, 1 Chome, Ueno, Taito-ku, TOKYO, 110-8534 JAPAN

LV1605M

Specifications

Absolute Maximum Ratings at $T_a=25^{\circ}\text{C}$, pins 33, 57=GND

| Parameter | Symbol | Conditions | Ratings | Unit |
|-----------------------------|---------------|-------------|-------------|--------------------|
| Maximum supply voltage | $V_{CC\ max}$ | Pins 32, 51 | 5 | V |
| Allowable power dissipation | $P_d\ max$ | | 200 | mW |
| Operating temperature | T_{opr} | | -25 to +70 | $^{\circ}\text{C}$ |
| Storage temperature | T_{stg} | | -40 to +125 | $^{\circ}\text{C}$ |

Operating Condition at pins 33, 57=GND

| Parameter | Symbol | Conditions | Ratings | Unit |
|--|------------|------------|------------|------|
| Recommended supply voltage | V_{CC} | | 3.3 | V |
| Allowable operating supply voltage range | V_{CCop} | | 3.0 to 3.6 | V |

*** Operating Supply Voltage** at Limit of Operating Temperature, pins 33, 57=GND

| Parameter | Symbol | Conditions | Ratings | Unit |
|--|-------------|------------|------------|--------------------|
| Operating ambient temperature | T_{opr2} | | -10 to +75 | $^{\circ}\text{C}$ |
| Allowable operating supply voltage range | V_{CCop2} | | 3.0 to 3.6 | V |

Package Dimensions

unit : mm

3159A

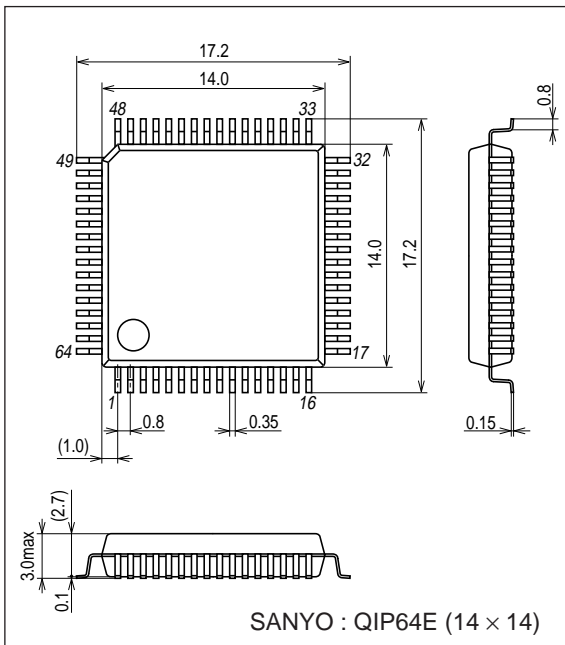

LV1605M

Electrical Characteristics/Operating Characteristics at Ta=25°C, with V_{CC} (pins 32, 51)=3.3V, GND (pins 33, 57)=0V

| Parameter | Symbol | Conditions | Ratings | | | Unit |
|--|---------------------|--|---------|--------|-------|------|
| | | | min | typ | max | |
| Current drain (active mode) | ICCO | AV _{CC} (pin32) + DV _{DD} (pin51), pin55=3.3V | 5 | 16 | 30 | mA |
| Current drain (sleep mode) | ICCs | AV _{CC} (pin32) + DV _{DD} (pin51), pin55=0V | | 7.5 | | mA |
| Reference voltage | VREF | VR | 1.50 | 1.65 | 1.80 | V |
| Interface: CE - Vtp | CEvtp | CE | | 1.9 | | V |
| Interface: CE - Vtn | CEvtn | CE | | 1.2 | | V |
| Interface: CL - Vtp | CLvtp | CL | | 1.9 | | V |
| Interface: CL - Vtn | CLvtn | CL | | 1.2 | | V |
| Interface: DAT - Vtp | DATvtp | DAT | | 1.9 | | V |
| Interface: DAT - Vtn | DATvtn | DAT | | 1.2 | | V |
| Interface: Maximum CL frequency | CLmax | | 500 | | | kHz |
| RF amplifier: RFSM no signal voltage | RFSMo | RW=H, L | 0.60 | 1.15 | 1.70 | V |
| RF amplifier: Minimum gain (normal) | RFSMgmin1 | FIN1, FIN2: 100kΩ-input, PH1=2.65V RW=H, freq-200kHz, RFSM | 0.5 | 4.5 | 8.5 | dB |
| RF amplifier: Minimum gain (CD-RW) | RFSMgmin1 | FIN1, FIN2: 100kΩ-input, PH1=2.65V RW=L, freq-200kHz, RFSM | 12.5 | 16.5 | 20.5 | dB |
| Focus amplifier: FDO gain MIN (Normal) | FDg1 | FIN1, FIN2: 100kΩ-input, FIN1=-FIN2, RW=H, FDO, SCI=VR, PH1=2.65V, freq-10kHz, FD | -3.5 | +0.5 | +4.5 | dB |
| Focus amplifier: FDO gain MIN (CD-RW) | FDg2 | FIN1, FIN2: 100kΩ-input, FIN1=-FIN2, RW=H, FDO, SCI=VR, PH1=2.65V, freq-10kHz, FD | | +12.5 | | dB |
| Focus amplifier: FDO gain MAX (Normal) | FDg1 | FIN1, FIN2: 100kΩ-input, FIN1=-FIN2, RW=H, FDO, SCI=VR, PH1=1.0V, freq-10kHz, FD | | +6.5 | | dB |
| Focus amplifier: FDO gain MAX (CD-RW) | FDg2 | FIN1, FIN2: 100kΩ-input, FIN1=-FIN2, RW=L, FDO, SCI=VR, PH1=1.0V, freq-10kHz, FD | | +18.5 | | dB |
| Focus amplifier: FDO offset (Normal) | FDost1 | The difference from the reference voltage, RW=high, servo on, FH=VR | -300 | 0 | +300 | mV |
| Focus amplifier: FDO offset (CD-RW) | FDost2 | The difference from the reference voltage, RW=low, servo on, FH=VR | -450 | 0 | +450 | mV |
| Focus amplifier: Offset when off (Normal) | FDofost1 | The difference from the reference voltage, RW=high, servo off, FH=VR | -100 | 0 | +100 | mV |
| Focus amplifier: Offset when off (CD-RW) | FDofost2 | The difference from the reference voltage, RW=low, servo off, FH=VR | -100 | 0 | +100 | mV |
| Focus amplifier: Offset adjustment step | FEstep | FE | | 18 | | mV |
| Focus amplifier: F search voltage H1 | FSmax1 | FDO, FSS=ground, the difference from VR | | 0.25 | | V |
| Focus amplifier: F search voltage L1 | FSmin1 | FDO, FSS=ground, the difference from VR | | -0.25 | | V |
| Focus amplifier: F search voltage H2 | FSmax2 | FDO, FSS=V _{CC} , the difference from VR | | 0.25 | | V |
| Focus amplifier: F search voltage L2 | FSmin2 | FDO, FSS=V _{CC} , the difference from VR | | 0 | | V |
| Tracking amplifier: TE gain MAX (CD) | TEgmax1 | freq-10kHz, E, F: 180kΩ-input, E=-F, PH1=1.0V, RW=H, TE | +17.5 | +21.75 | +26.0 | dB |
| Tracking amplifier: TE gain MAX (CD-R) | Tegmax2 | freq-10kHz, E, F: 180kΩ-input, E=-F, PH1=1.0V, RW=H, TE | | +18.75 | | dB |
| Tracking amplifier: TE gain MAX (CD-RW) | Tegmax3 | freq-10kHz, E, F: 180kΩ-input, E=-F, PH1=1.0V, RW=L, TE | | +33.75 | | dB |
| Tracking amplifier: TE gain MIN (CD) | TEgmin1 | f=10kHz, E, F: 180kΩ-input, E=-F, PH1=2.65V, RW=H, TE | +11.5 | +15.0 | +18.5 | dB |
| Tracking amplifier: TE gain MIN (CD-R) | Tegmin2 | f=10kHz, E, F: 180kΩ-input, E=-F, PH1=2.65V, RW=H, TE | | +12.0 | | dB |
| Tracking amplifier: TE gain MIN (CD-RW) | Tegmin3 | f=10kHz, E, F: 180kΩ-input, E=-F, PH1=2.65V, RW=L, TE | +23.0 | +27.25 | +31.5 | dB |
| Tracking amplifier: ΔTE (200k) | ΔTE _{200k} | E, F:180kΩ-input, RW=H, E=-F, TE, ΔTE _{200k} =TE (10kHz) - TE(200kHz) | | 12.0 | | dB |
| Tracking amplifier: TGL offset (Normal) | TGLost1 | Servo: on, TH=VR, TGL=H, RW=H, TO | -250 | 0 | +250 | mV |
| Tracking amplifier: TGL offset (CD-RW) | TGLost2 | Servo: on, TH=VR, TGL=H, RW=L, TO | -450 | 0 | +450 | mV |
| Tracking amplifier: THLD offset (Normal) | THLDost1 | THLD mode, RW=high, the difference from VR, TA | -120 | 0 | +120 | mV |
| Tracking amplifier: THLD offset (CD-RW) | THLDost2 | THLD mode, RW=low, the difference from VR, TA | -120 | 0 | +120 | mV |
| Tracking amplifier: Off 1 offset | OFF1ost | TOFF=H, TO | -120 | 0 | +120 | mV |
| Tracking amplifier: Off 2 offset | OFF2ost | TOF2 off (IF), TO | -120 | 0 | +120 | mV |
| Tracking amplifier: Offset adjustment step | TEstep | TE | | 40 | | mV |
| Tracking amplifier: Balance range - high | BAL-H | Δgain E/F input, TB=3.3V | | +3.5 | | dB |
| Tracking amplifier: Balance range - low | BAL-L | Δgain E/F input, TB=0V | | -3.5 | | dB |

Continued on next page.

LV1605M

Continued from preceding page.

| Parameter | Symbol | Conditions | Ratings | | | Unit |
|--|----------|---|---------|--------|-------|------|
| | | | min | typ | max | |
| Tracking servo switching threshold TOFF-VTH | TOFFvth | | +1.0 | | +2.05 | V |
| Tracking gain switching threshold TGL-VTH | TGLvth | | +1.0 | | +3.05 | V |
| PH No signal voltage | PHo | The difference from RFSM | -0.9 | -0.65 | -0.4 | V |
| BH No signal voltage | BHo | The difference from RFSM | +0.4 | +0.65 | +0.9 | V |
| DRF Detection voltage | DRFvth | The difference from VR at RFSM | -0.40 | -0.2 | 0 | V |
| DRF Output voltage - high | DRF-H | | +2.7 | +3.15 | | V |
| DRF Output voltage - low | DRF-L | | | 0 | +0.5 | V |
| FZD Detection voltage 1 | FZD1 | FE, the difference from VR | 0 | +0.2 | | V |
| FZD Detection voltage 2 | FZD2 | FE, the difference from VR | | 0 | | V |
| HFL Detection voltage | HFLvth | The difference from VR at RF | | -0.18 | | V |
| HFL Output voltage - high | HFL-H | | +2.4 | +3.15 | | V |
| HFL Output voltage - low | HFL-L | | | 0 | +0.5 | V |
| TES Detection voltage LH | TES-LH | TESI, the difference from VR | -0.15 | -0.085 | -0.02 | V |
| TES Detection voltage HL | TES-HL | TESI, the difference from VR | +0.02 | +0.085 | +0.15 | V |
| TES Output voltage - high | TES-H | | +2.3 | +3.15 | | V |
| TES Output voltage - low | TES-L | | | 0 | +0.5 | V |
| JP Output voltage - high | JP-H | TJP=3.3V, at SLD | | +1.0 | | V |
| JP Output voltage - low | JP-L | TJP=0V, at SLD | | -1.0 | | V |
| Spindle amplifier: Offset12 | SPD12ost | The difference from VR at SPD, 12cm mode | -100 | 0 | +100 | mV |
| Spindle amplifier: Offset8 | SPD8ost | The difference from VR at SPD, 8cm mode | -100 | 0 | +100 | mV |
| Spindle amplifier: Offset off | SPDof | The difference from VR at SPD, off mode | -120 | 0 | +120 | mV |
| Spindle amplifier: Output voltage H12 | SPD-H12 | The difference from offset 12, 12cm mode, CLV=3.3V | +0.3 | +0.5 | +0.8 | V |
| Spindle amplifier: Output voltage L12 | SPD-L12 | The difference from offset 12, 12cm mode, CLV=0V | -0.8 | -0.5 | -0.3 | V |
| Spindle amplifier: Output voltage H8 | SPD-H8 | The difference from offset 8, 8cm mode, CLV=3.3V | +0.1 | +0.23 | +0.36 | V |
| Spindle amplifier: Output voltage L8 | SPD-L8 | The difference from offset 8, 8cm mode, CLV=0V | | -0.23 | | V |
| Sled amplifier: SLEQ offset | SLDost | The difference from TO at SLEQ | -70 | 0 | +70 | mV |
| Sled amplifier: Offset SLD | SLDost | The difference from VR when SLEQ=VR | -180 | 0 | +280 | mV |
| Sled amplifier: Offset off | SLDof | Off mode | -180 | 0 | +280 | mV |
| Disc switching: RW-VTH | RWvth | RW | +1.0 | +1.65 | +2.3 | V |
| Anti-shock: No signal voltage | SCIo | SCI, the difference from VR | -70 | 0 | +70 | mV |
| Anti-shock: Detection voltage - high | SClvthH | SCI, the difference from VR | +20 | +80 | +140 | mV |
| Anti-shock: Detection voltage - low | SClvthL | SCI, the difference from VR | -140 | -80 | -20 | mV |
| Defect: Detection voltage | DEFvth | With RFSM=2.0V, the difference between the LF2 voltage on disc defect detection and the LF2 voltage when RF=2.0V. | +0.10 | +0.35 | +0.60 | V |
| Defect: Output voltage - high | DEF-H | | 2.4 | 3.0 | | V |
| Defect: Output voltage - low | DEF-L | | | 0 | +0.5 | V |
| APC: Reference voltage | LDS | The LDS voltage such that LDD=1.65V | +100 | +170 | +240 | mV |
| APC: Off voltage | LDDof | LDD | +2.85 | +3.15 | | V |

LV1605M

Pin Functions

| Pin No. | Pin name | I/O | Description |
|---------|----------|-----|--|
| 1 | FIN2 | I | Pickup photodiode connection. The RF signal is generated by adding to the FIN1 pin, and the FE signal is generated by subtracting. |
| 2 | FIN1 | I | Pickup photodiode connection |
| 3 | E | I | Pickup photodiode connection. The TE signal is generated by subtraction with the F pin. |
| 4 | F | I | Pickup photodiode connection |
| 5 | TB | I | TE signal DC component input |
| 6 | TE- | | The TE signal gain is set by connecting a resistor between this pin and the TE pin. |
| 7 | TE | O | TE signal output |
| 8 | TESI | I | TES (tracking error sense) comparator input. Apply a bandpass filter to the TE signal and input the result to this pin. |
| 9 | SCI | I | Shock detection input |
| 10 | TH | | Tracking gain time constant setting |
| 11 | TA | | TA amplifier output |
| 12 | TD- | | Used for the tracking phase compensation constant formed between the TD and VR pins. |
| 13 | TD | I | Tracking phase compensation constant connection |
| 14 | JP | | Tracking jump signal (kick pulse) amplitude setting |
| 15 | TO | O | Tracking control signal output |
| 16 | FD | O | Focusing control signal output |
| 17 | FD- | | Used for the focusing phase compensation constant formed between the FD and FA pins. |
| 18 | FA | | Used for the focusing phase compensation constant formed between the FD- and FA- pins. |
| 19 | FA- | | Used for the focusing phase compensation constant formed between the FA and FE pins. |
| 20 | FHO | | Focus gain time constant setting |
| 21 | FE | O | FE signal output |
| 22 | FE- | | The FE signal gain is set by connecting a resistor between this pin and the FE pin. |
| 23 | FH | | Focus gain time constant setting |
| 24 | SP | O | CLV input signal single-end output |
| 25 | SPG | | Spindle 12 cm mode gain setting resistor connection |
| 26 | SP- | | Used for the spindle phase compensation constant in conjunction with the SPD pin. |
| 27 | SPD | O | Spindle control signal output |
| 28 | SLEQ | | Sled phase compensation constant setting |
| 29 | SLD | O | Sled control signal output |
| 30 | SL- | I | Input for the sled advance signal from the microcontroller. |
| 31 | SL+ | I | Input for the sled advance signal from the microcontroller. |
| 32 | DVCC | | Digital system V _{CC} |
| 33 | DGND | | Digital system ground |
| 34 | TGL | I | Input for tracking gain control signal from the DSP. The gain is low when TGL is high. |
| 35 | TOFF | I | Input for tracking gain control signal from the DSP. The gain is off when TOFF is high. |
| 36 | TES | O | Outputs for the TES signal to the DSP. |
| 37 | TJP | I | Input for the tracking jump signal from the DSP |
| 38 | HFL | O | The high frequency level (HFL) signal is used to judge whether the position of the main beam is over a pit or over a mirror area. |
| 39 | CLV | I | CLV error signal from the DSP |
| 40 | INTI | I | Forced defect detected state signal input |
| 41 | CL | I | Microcontroller command clock input |
| 42 | DAT | I | Microcontroller command data input |
| 43 | CE | I | Microcontroller command chip enable input |
| 44 | RW | I | Gain switching input. RW=high: CD mode, RW=low: CD-RW mode. |
| 45 | CLK | I | Reference clock input. The DSP 130kHz clock signal is input to this pin. |
| 46 | DEF | O | Disc defect detection output |
| 47 | DRF | O | Defect RF: RF level detection output |
| 48 | RFSM | O | RF output |
| 49 | RF- | | In conjunction with the RFSM pin, sets the RF gain and is used for the EFM signal 3T compensation constant setting. |
| 50 | PH1 | | RF signal peak hold capacitor connection |
| 51 | AVCC | | Analog system V _{CC} . |
| 52 | NC | | NC (no connection) |
| 53 | FAJON | I | Focus offset adjustment mode switching. FAJON=low: normal mode, FAJON=high: constant voltage FD mode. |
| 54 | FSS | I | Focus search select (FSS): focus search mode (± or + search relative to the reference voltage) switching. |
| 55 | PON | I | Power On. PON=high: active mode, PON=low: sleep mode |
| 56 | LF2 | | Disc defect detection time constant setting |
| 57 | AGND | | Analog system ground |
| 58 | FSC | | Focus search smoothing capacitor connection |
| 59 | BH1 | | RF signal bottom hold capacitor connection |
| 60 | REFI | | Reference voltage bypass capacitor connection |
| 61 | VR | O | Reference voltage output |
| 62 | LDD | O | APC circuit output |
| 63 | LDS | I | APC circuit input |
| 64 | TC | | Tracking signal peak hold capacitor connection |

Switching Characteristics

Relationships Between Control Pin Voltages and Operating Modes
(VCC (pins 32, 51)=3.3V, GND (pins 33, 57)=0V)

TGL (pin 34) Tracking gain switching

| Mode | Min | Max |
|-----------|-------|------|
| High gain | 0V | 0.5V |
| Low gain | 3.05V | 3.3V |

TOFF (pin 35) Tracking servo on/off switching

| Mode | Min | Max |
|---------------------|-------|------|
| Tracking servo: on | 0V | 0.5V |
| Tracking servo: off | 2.05V | 3.3V |

INTI (pin 40) Forces the defect detection signal to the high level

| Mode | Min | Max |
|---|------|------|
| Defect detected signal forced to high function: on | 0V | 1.0V |
| Defect detected signal forced to high function: off | 2.0V | 3.3V |

RW (pin 44) RF and servo system high gain (+12 dB) switching

| Mode | Min | Max | Gain increase |
|------------|------|------|---------------|
| CD mode | 2.0V | 3.3V | Low |
| CD-RW mode | 0V | 1.0V | Hi |

FAJON (pin 53) Focus offset adjustment mode switching

| Mode | Min | Max |
|------------------------------|------|------|
| Sony coupler mode | 2.0V | 3.3V |
| Coupler other than Sony mode | 0V | 1.0V |

FSS (pin 54) Focus search mode switching

| Mode | Min | Max |
|--|------|------|
| Search \pm relative to the reference voltage | 3.0V | 3.3V |
| Search only in the + direction relative to the reference voltage | 0V | 0.5V |

PON (pin 55) Sleep mode switching

| Mode | Min | Max |
|-------------|------|------|
| Active mode | 3.0V | 3.3V |
| Sleep mode | 0V | 0.5V |

LV1605M

Equivalent Circuit

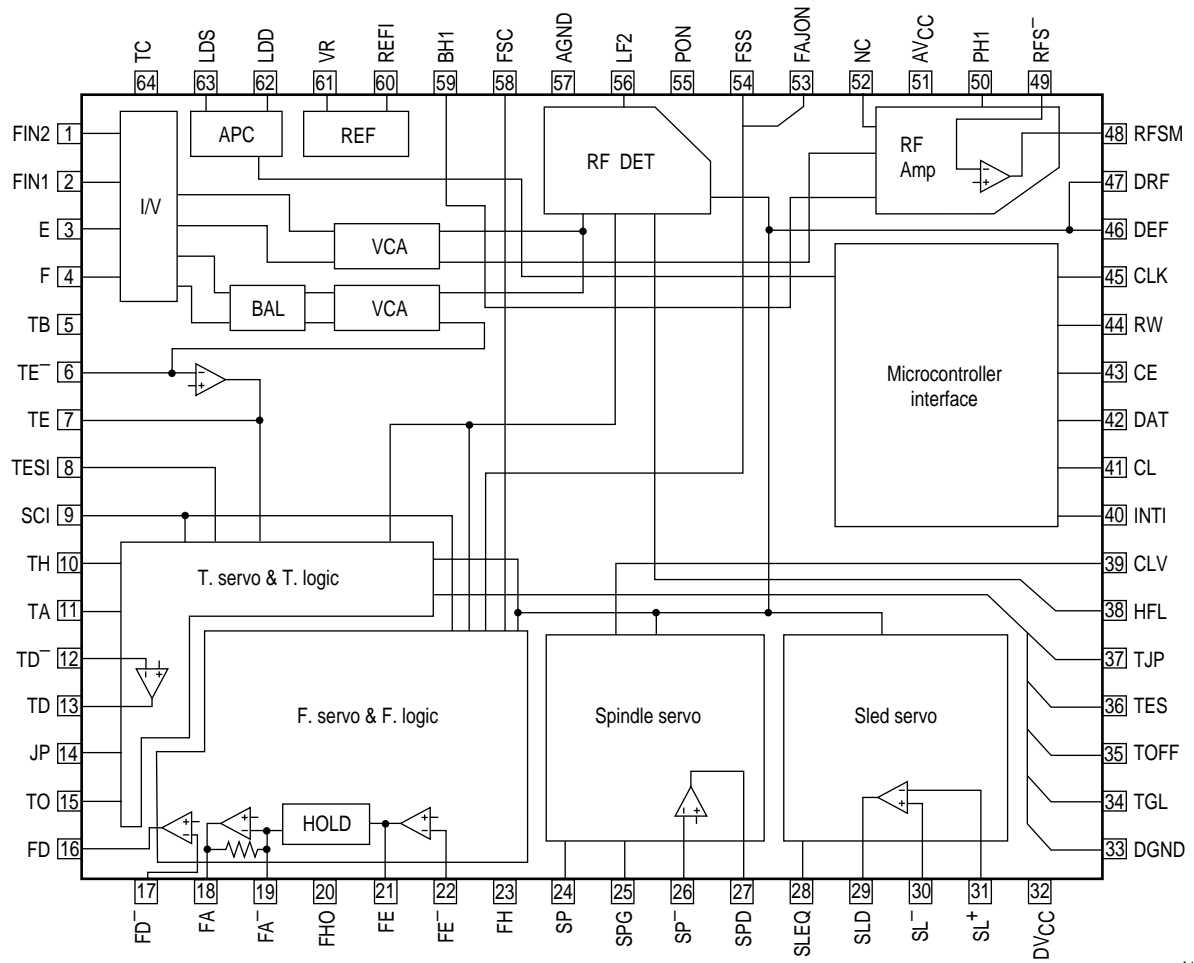

A13932

LV1605M

Test Circuit

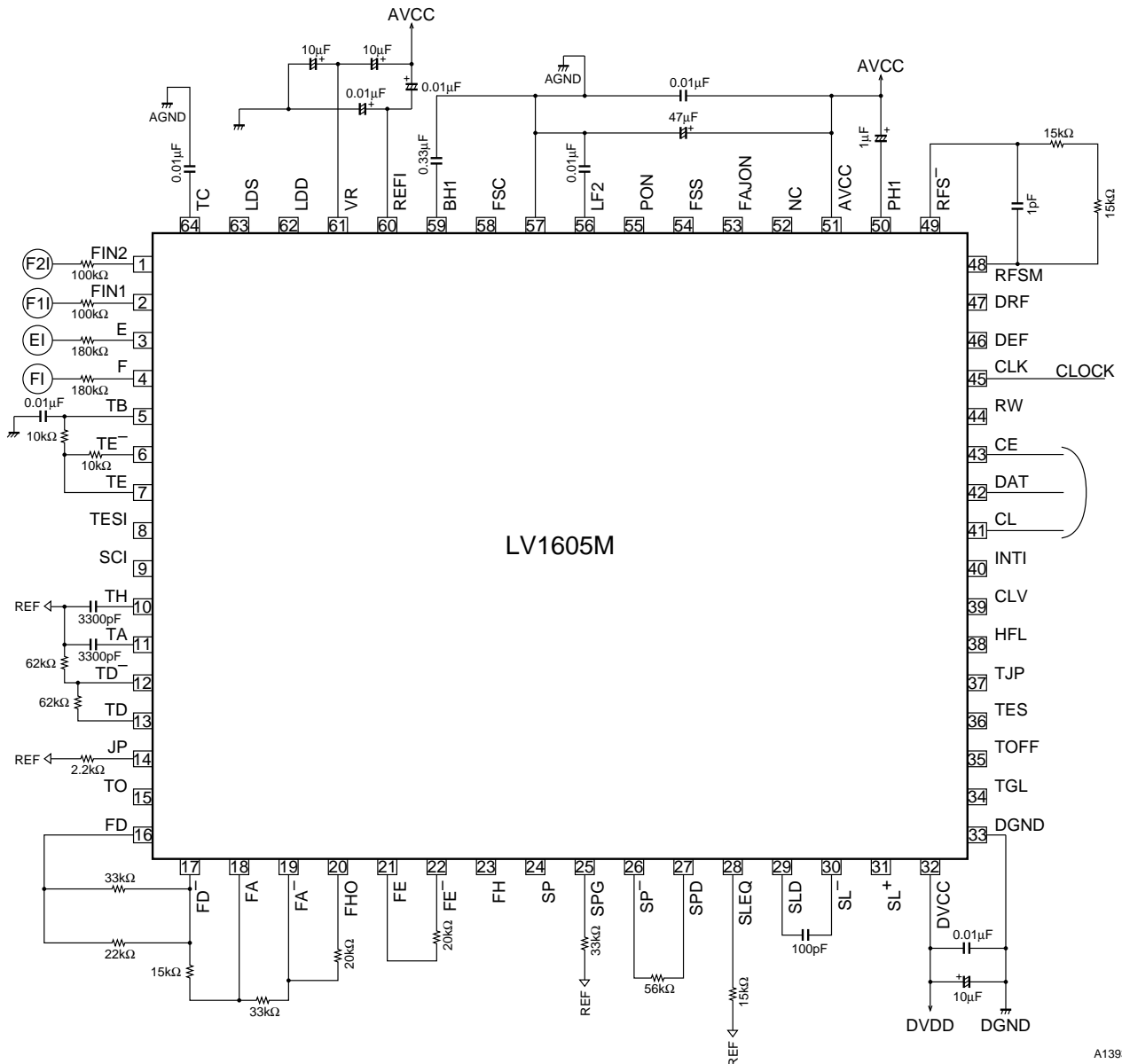

A13933

Operational Description

- **APC (Automatic laser power control)**
This circuit is provided to control the pickup laser power. The laser on/off state is set by the microcontroller.
- **RF amplifier (eye pattern output)**
The (A + C) component of the pickup photodiode output current is input to FIN2 (pin 1), and the (B + D) component is input to FIN1 (pin 2). The input current is converted to a voltage. That signal is passed through the AGC circuit and output from the RFSM amplifier output RFSM pin (pin 48). The internal AGC circuit has a variable gain range of ± 3 dB, and its time constant can be changed by adjusting the value of the external capacitor connected to PH1 (pin 50). The bottom level of the EFM signal (the RFSM output) is controlled, and the response of this function can be changed by adjusting the value of the external capacitor connected to BH1 (pin 59). The center value of the range of the AGC circuit is set by the value of the resistor inserted between RFSM (pin 48) and RFS- (pin 49). If required, these pins can also be used for EFM signal 3T compensation. When playing CD-RW discs, the input gain is increased when the IC receives a signal from the DSP that sets RW (pin 44) low.

- Focus Servo

The focus error signal is acquired by detecting the difference $(B+D) - (A+C)$ of the $(A+C)$ and $(B+D)$ signals from the pickup. This focus error signal is then passed through the VCA circuit, whose gain following is controlled by the RF AGC circuit, and is output from FE (pin 21). The gain applied to the focus error signal is set by the value of the resistor connected between FE (pin 21) and FE- (pin 22). When playing CD-RW discs, the input gain is increased when the IC receives a signal from the DSP that sets RW (pin 44) low.

Offset cancellation is applied to the FE amplifier. This offset cancellation operation is provided to cancel the offset of the IC's internal I-V amplifier and other circuits. Adjustment of this function is started by issuing a FOCUS-OFFSET ADJUST START command and completes about 130ms later. The FOCUS-OFFSET ADJUST OFF command is provided to return the IC's state to the state preceding the offset cancellation operation.

The FA amplifier is provided as a pickup phase compensation amplifier, and its equalizer curve is set with an external capacitor and resistor. This amplifier has a muting function, and mutes the output either when an F-SERVO OFF command is issued in V_{CC} ON mode or during an F-SEARCH operation. Issue either a LASER ON or an F-SERVO ON command to turn focus search on.

The FH amplifier modifies the servo response characteristics on disc defect detection with SCI (pin 9).

The FD amplifier includes both a phase compensation circuit and a focus search signal synthesis function. A focus search operation is started with the F-SEARCH command, a ramp waveform is generated using an internal clock, and the operation completes in about 560ms. Focus is detected (focus zero cross detection) using the focus error signal created from that waveform, and the focus servo is turned on. The amplitude of the ramp waveform is set by the value of the resistor connected between FD (pin 16) and FD- (pin 17).

FSC (pin 58) is used to smooth the focus search ramp waveform; a capacitor for this purpose is connected between FSC and REF.

FSS (pin 54) is the focus search mode switching pin; if FSS is shorted to V_{CC} , the IC performs a + search relative to the reference voltage, and if FSS is left open or shorted to ground, the IC performs a \pm search.

FAJON (pin 53) is the focus offset adjustment mode switching pin, and is normally shorted to ground. Short this pin to V_{CC} to set the IC to operate in Sony coupler mode.

- Tracking servo

The photodiode output current is input to E (pin 3) and F (pin 4). The input current is I-V converted, and the voltage signal passes through first the balance adjustment VCA circuit and then the VCA circuit, whose gain following is controlled by the RF AGC circuit, and is output from TE (pin 7). The value of the resistor connected between TE- (pin 6) and TE (pin 7) sets the tracking error gain. When playing CD-RW discs, the input gain is increased when the IC receives a signal from the DSP that sets RW (pin 44) low. Furthermore, in E/F balance mode, the gain is lowered by 3 dB when the tracking signal peak value is over $V_{REF} + 0.6V$.

Offset cancellation is applied to the TE amplifier. This offset cancellation operation completes in about 60ms. The TRACK-OFFSET ADJUST OFF command is provided to return the IC's state to the state preceding the offset cancellation operation.

The TH amplifier detects either the TGL signal from the DSP or the JP signal, and changes the servo response characteristics according to the internally generated THLD signal and other signals. The tracking servo switches to THLD mode internally on disc defect detection. This operation can be avoided by simply shorting DEF (pin 46) to ground (the low level). A bandpass filter that extracts just the mechanical shock (skip detection) component from the tracking error signal is formed externally at SCI (pin 9), and if injected, the gain is increased automatically when a shock (skip) is detected.

The LV1605M includes an internal resistor so that a low-pass filter can be formed at the TA output (pin 11).

The TD amplifier is a circuit provided for servo loop phase compensation. Its characteristics are set with an external RC circuit. This amplifier has a muting function, and the muting function operates either when V_{CC} is turned on and when a TRACK-SERVO OFF command has been issued. This muting function is released when a TRACK-SERVO ON command is issued.

The TOFF amplifier immediately following TD (pin 13), functions to turn off the servo according to the TOFF signal from the DSP.

The TO amplifier includes a function for synthesizing JP pulses, and the JP pulse is set with JP (pin 14). (THLD is detected internally.)

- Sled servo

The response characteristics are set with SLEQ (pin 28). The amplifier that follows SLEQ (pin 28) provides a muting function; that muting function is turned on by the SLED OFF command. The sled is advanced by applying a current input to SL- (pin 29) and SL+ (pin 30). In particular, connect the SLEQ pin to a microcontroller output port via a resistor, and set the sled advance gain by the value of that resistor. Note that an offset in the SLD output will occur if there is a discrepancy between the values of the SL- (pin 29) and SL+ (pin 30) resistors. The muting function also operates on disc defect detection.

- Spindle servo

A servo circuit to hold the disc at a constant linear speed is formed in conjunction with the DSP. The IC receives a signal from the DSP at CLV (pin 39) and outputs a signal from SPD (pin 27). The equalizer characteristics are set with SP (pin 24), SP- (pin 26), and SPD (pin 27). The 12cm mode amplifier gain is set by the resistor connected between SPG (pin 25) and the reference voltage. In 8cm mode, the amplifier is buffered internally and independent of SPG (pin 25). Note that the gain must first be set for 8cm mode and then set for 12cm mode. Note that circuit can be forcibly set to the 8cm mode gain regardless of the 8/12cm mode setting by setting SPG (pin 25) to the open state. The muting function operates on disc defect detection.

- TES and HFL (traversal signals)

When the pickup moves from the outside of the disc towards the inside, the EF output from the pickup is connected so that the HFL and TES signals have the phase relationship shown in the figure. The TES comparator is a negative polarity comparator with respect to the TESI input, and has a hysteresis of about $\pm 100\text{mV}$. A bandpass filter used to extract only the required signal components from the TE signal is formed externally.

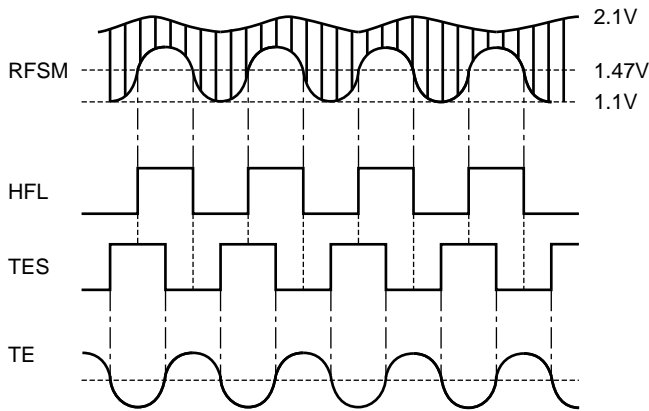

A13934

- DRF (optical amplitude judgment)

A peak hold function using the PH1 (pin 50) capacitor is applied to the EFM signal (RFSM output). This circuit outputs a high level when the RFSM peak value exceeds about 1.45V. The PH1 (pin 50) capacitor is related to the settings for both the DRF detection time constant and the RF AGC response.

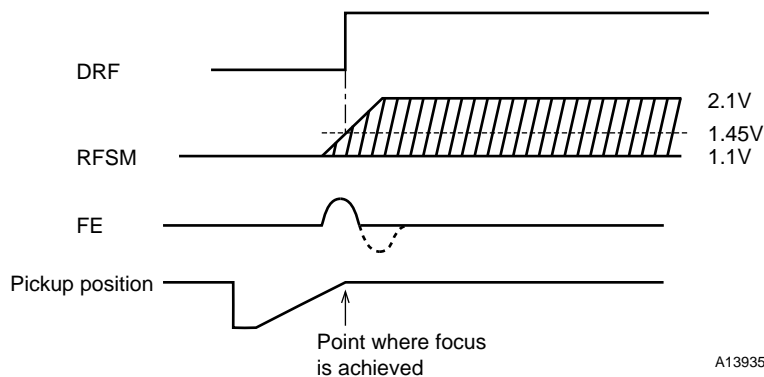

A13935

• Focus judgment

The pickup is judged to get in focus when the Scurve reaches the REF level after the level REF + 0.2 V has been detected in the focus error signal Scurve.

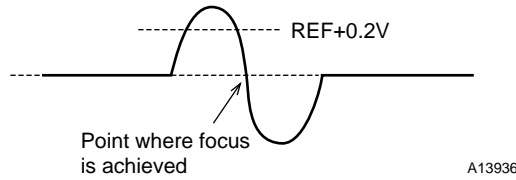

• Disc defect detection

The mirror surface detection level is held by the capacitor connected to LF2 (pin 56), and a high level is output from DEF (pin 46) if the dropout level in the EFM signal (RFSM output) rises above 0.35V. When DEF (pin 46) goes high, the tracking servo goes to THLD mode. To prevent the tracking servo from going to THLD mode when a disc defect is detected, either short DEF (pin 46) or short LF2 (pin 56) to ground. This prevents the DEFECT output from being issued.

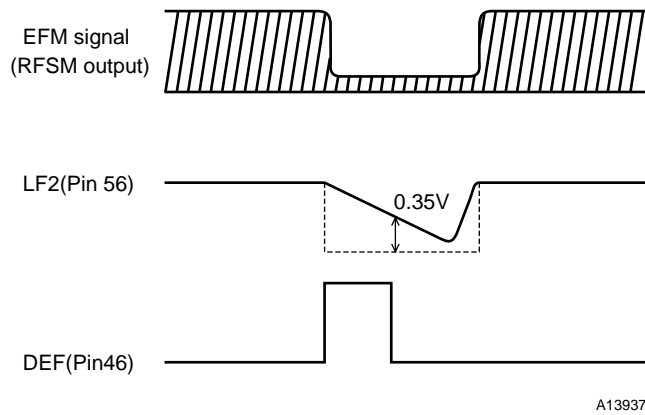

• Microcontroller interface

Since the Reset (Nothing) command initializes the LV1605M, it must be used with care. The LV1605M's command acceptance (mode switching) timing is such that the mode switches on the (130kHz) clock cycle following the CE (RWC) falling edge. Therefore, a low-level period in the CE signal of at least 10 μs is required when issuing consecutive commands. The 130kHz clock is required for this reason. The various LV1605M instructions can be issued by setting CE high and then, in synchronization with the CL clock, issuing the command from the microcontroller, LSB first, to DAT (pin 42). Note that commands are executed starting at the fall of the CE signal.

Timing Chart

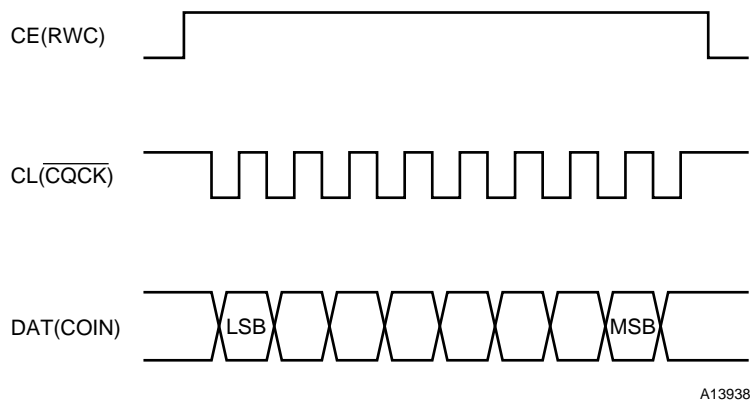

* Items in parentheses are DSP pin names.

LV1605M

- Reset circuit
The power on reset is cleared when V_{CC} rises above about 2.0V.
- Notes on PCB pattern design
Since noise may enter RFSM (pin 48) from CLV (pin 39), shielding must be run between these lines.
- VCC, REF, GND, and NC pins
AVCC (pin 51): Analog system
DVCC (pin 32) Digital system
AGND (pin 57): Analog system
DGND (pin 33): Digital system
NC (pin 52): No connect
VR (pin 61): Reference voltage

Command Table

| MSB | LSB | Command | During a reset During the power on state | DSP | | | | | | |
|-----|-----|---------|---|-----|---|---|---|-------------------------------|--------------------------|-----------------|
| 0 | 0 | 0 | 0 | 0 | 0 | 0 | 0 | RESET | | RESET (Nothing) |
| 0 | 0 | 0 | 0 | 1 | 0 | 0 | 0 | FOCUS START | | FOCUS START#1 |
| 1 | 0 | 0 | 1 | 0 | 0 | 0 | 0 | FOCUS-OFFSET ADJUSTMENT START | | |
| 1 | 0 | 0 | 1 | 0 | 0 | 0 | 1 | FOCUS-OFFSET ADJUSTMENT OFF | ○ | |
| 1 | 0 | 0 | 1 | 0 | 0 | 1 | 0 | TRACK-OFFSET ADJUSTMENT START | | |
| 1 | 0 | 0 | 1 | 0 | 0 | 1 | 1 | TRACK-OFFSET ADJUSTMENT OFF | ○ | |
| 1 | 0 | 0 | 1 | 0 | 1 | 0 | 0 | LASER ON: F-SERVO ON | | |
| 1 | 0 | 0 | 1 | 0 | 1 | 0 | 1 | LASER OFF: F-SERVO ON | | |
| 1 | 0 | 0 | 1 | 0 | 1 | 1 | 0 | LASER OFF: F-SERVO OFF | ○ | |
| 1 | 0 | 0 | 1 | 0 | 1 | 1 | 1 | SPINDLE 8CM | | |
| 1 | 0 | 0 | 1 | 1 | 0 | 0 | 0 | SPINDLE 12CM | ○ | |
| 1 | 0 | 0 | 1 | 1 | 0 | 0 | 1 | SPINDLE OFF | | |
| 1 | 0 | 0 | 1 | 1 | 0 | 1 | 0 | SLED ON | | |
| 1 | 0 | 0 | 1 | 1 | 0 | 1 | 1 | SLED OFF | | |
| 1 | 0 | 0 | 1 | 1 | 1 | 0 | 0 | E/F BALANCE START | Adjustment not performed | |
| 1 | 0 | 0 | 1 | 1 | 1 | 0 | 1 | TRACK-SERVO OFF | | |
| 1 | 0 | 0 | 1 | 1 | 1 | 1 | 0 | TRACK-SERVO ON | | |

Notes on Microcontroller Software Implementation

- Command relationships

Since the IC internal registers are cleared after either a FOCUS START or an E/F BALANCE START command is issued, applications must issue a 11111110 (= FEh (hexadecimal)) command after either of those commands.

Reason: Those two commands are executed at point (1) in the timing chart below. However, after that, if a CE signal such as that shown below is input, the data will be executed again as the same command at point (2) in the timing chart.

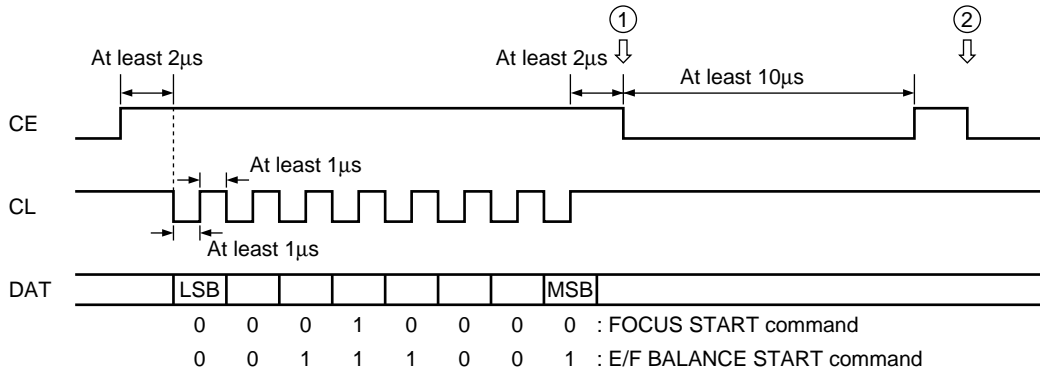

A13939

When either a TRACK-OFFSET ADJUST START or a FOCUS-OFFSET ADJUST START command is issued after either a VCC ON (POWER ON RESET), RESET, or a corresponding OFFSET ADJUST OFF command, the wait time shown below is required. (Note that this applies in the state where the 130kHz clock is input.)

- TRACK-OFFSET ADJUST START: At least 4ms
- FOCUS-OFFSET ADJUST START: At least 4ms

- Notes on E/F balance adjustment

The E/F balance adjustment must be performed not on a disc mirror area, but on a disc pit area.

Also, since track kick operations are not performed during the EF balance adjustment, care must be taken that a stable TE signal is acquired. (For example, by performing sled advance operations from the microcontroller.)

LV1605M

Pin Internal Equivalent Circuits

| Pin No. | Pin | Equivalent circuit |
|---------------------------|----------------------------------|--|
| 1 2 | FIN2 FIN1 | <p style="text-align: right;">A13940</p> |
| 3 4 | E F | <p style="text-align: right;">A13941</p> |
| 5 | TB | <p style="text-align: right;">A13942</p> |
| 6 17 22 26 28 | TE- FD- FE- SP- SLEQ | <p style="text-align: right;">A13943</p> |

Continued on next page.

LV1605M

Continued from preceding page.

| Pin No. | Pin | Equivalent circuit |
|---------------------|----------------------|--|
| 7 10 21 23 | TE TH FE FH | <p style="text-align: right;">A13944</p> |
| 8 36 | TESI TES | <p style="text-align: right;">A13945</p> |
| 9 34 | SCI TGL | <p style="text-align: right;">A13946</p> |
| 11 12 | TA TD- | <p style="text-align: right;">A13947</p> |

Continued on next page.

LV1605M

Continued from preceding page.

| Pin No. | Pin | Equivalent circuit |
|----------------|------------------|--|
| 13 | TD | <p style="text-align: right;">A13948</p> |
| 14 | JP | <p style="text-align: right;">A13949</p> |
| 15 | TO | <p style="text-align: right;">A13950</p> |
| 16 27 58 | FD SPD FSC | <p style="text-align: right;">A13951</p> |

Continued on next page.

LV1605M

Continued from preceding page.

| Pin No. | Pin | Equivalent circuit |
|----------------|-------------------|--|
| 18 19 20 | FA FA- FHO | <p style="text-align: right;">A13952</p> |
| 24 25 | SP SPG | <p style="text-align: right;">A13953</p> |
| 29 30 31 | SLD SL- SL+ | <p style="text-align: right;">A13954</p> |
| 35 | TOFF | <p style="text-align: right;">A13955</p> |

Continued from preceding page.

LV1605M

Continued from preceding page.

| Pin No. | Pin | Equivalent circuit |
|----------------|-------------------|--------------------|
| 37 | TJP | |
| 38 46 47 | HFL DEF DRF | |
| 39 | CLV | |
| 40 | INTI | |

Continued from preceding page.

LV1605M

Continued from preceding page.

| Pin No. | Pin | Equivalent circuit |
|----------------------|------------------------|--|
| 41 42 43 45 | CL DAT CE CLK | <p style="text-align: right;">A13960</p> |
| 44 | RW | <p style="text-align: right;">A13961</p> |
| 48 50 59 | RFSM PH1 BH1 | <p style="text-align: right;">A13962</p> |
| 49 | RF- | <p style="text-align: right;">A13963</p> |

Continued from preceding page.

LV1605M

Continued from preceding page.

| Pin No. | Pin | Equivalent circuit |
|---------|-------|--|
| 53 | FAJON | <p style="text-align: right; font-size: small;">A13964</p> |
| 54 | FSS | <p style="text-align: right; font-size: small;">A13965</p> |
| 55 | PON | <p style="text-align: right; font-size: small;">A13966</p> |
| 56 | LF2 | <p style="text-align: right; font-size: small;">A13967</p> |

Continued from preceding page.

LV1605M

Continued from preceding page.

| Pin No. | Pin | Equivalent circuit |
|----------|------------|--|
| 60 61 | REFI VR | <p style="text-align: right; font-size: small;">A13968</p> |
| 62 | LDD | <p style="text-align: right; font-size: small;">A13969</p> |
| 63 | LDS | <p style="text-align: right; font-size: small;">A13970</p> |
| 64 | TC | <p style="text-align: right; font-size: small;">A13971</p> |

LV1605M

| Product | LA9230M | LA9240M | LA9241M | LA9242M | LV1605M |
|--|----------------------------------|---------------------------------|---------------------------------|---------------------------------|---|
| Package | QIP-64E | QIP-64E | QIP-64E | QIP-64E | QIP-64E |
| Allowable operating supply voltage | | | | | |
| V _{CCop} max | 5.5V | 5.5V | 5.5V | 5.5V | 3.6V |
| V _{CCop} min1 | 3.6V: t=-25 to +75°C | 3.6V: t=-25 to +75°C | 3.2V: t=-25 to +75°C | 3.2V: t=-25 to +75°C | 3.0V: t=-10 to +75°C |
| V _{CCop} min2 | | 3.4V: t=-5 to +75°C | 3.0V: t=-10 to +75°C | 3.0V: t=-10 to +75°C | |
| Recommended supply voltage | 5.0V | 5.0V | 5.0V | 5.0V | 3.3V |
| Current drain | 32mA | 32mA | 32mA | 34mA | 16mA |
| Automatic adjustment function | | | | | |
| Focus offset adjustment | | | | | Adjustment position: FE |
| Maximum adjustment time | Adjustment position: FD 270ms | Adjustment position: FE 30ms | Adjustment position: FE 30ms | Adjustment position: FE 30ms | (The adjustment range is four times that of the LA9242M) 130ms |
| Tracking offset adjustment | | | | | Adjustment position: TE |
| Maximum adjustment time | Adjustment position: TO 30ms | Adjustment position: TE 30ms | Adjustment position: TE 30ms | Adjustment position: TE 30ms | (The adjustment range is four times that of the LA9242M) 60ms |
| E/F balance automatic adjustment | ○ | ○ | ○ | ○ | ○ |
| RF level AGC function | | | | | |
| RF amplitude at the recommended supply voltage | 1.8Vp-p | 1.8Vp-p | 1.5Vp-p | 1.5Vp-p | 1.4Vp-p |
| RF amplitude at V _{CC} min | 1.3Vp-p | 1.2Vp-p: V _{CC} =3.4V | 0.9Vp-p: V _{CC} =3.0V | 0.9Vp-p: V _{CC} =3.0V | 1.3Vp-p: V _{CC} =3.0V |
| RF hold on disc defect detection | × | × | × | × | ○ |
| Tracking servo gain RF level following function | ○ | ○ | ○ | ○ | ○ |
| Focus servo gain RF level following function | × | × | × | × | ○ |
| Focus search time | About 280ms | About 560ms | About 560ms | About 560ms | About 560ms |
| Playback speed | 2 × | 4 × | 4 × | 4 × (normal mode) | 4 × |
| Tracking signal output (Track kick during E/F balance adjustment) | Built in | No output provided | No output provided | No output provided | No output provided |
| Focus search smoothing capacitor pin: FSC | × | ○ | ○ | ○ | ○ |
| E/F balance setting range adjustment pin: TBC | × | ○ | ○ | ○ | × |
| Focus search mode switching pin: FSS | × | ○ | ○ | ○ | ○ |
| HFL detection V _{th} | 2.3V | 2.1V | 2.1V | 2.1V | 1.47V |
| DRF current capacity | About 100μA | About 250μA | About 250μA | About 250μA | About 100μA |
| APC reference voltage The LCD voltage such that LDD=3V | 180mV: typ | 180mV: typ | 190mV: typ | 190mV: typ | 170mV: typ (The LDS voltage such that LDD=1.65V) |
| No connect pins | Pins 46, 47, 48, and 55 | Pin 48 | Pins 23 and 48 | Pins 23 and 48 | Pin 52 |
| RW disc playback support | × | × | × | ○ | ○ |
| Hold function for focus, spindle, and sled servos during disc defect detection | × | × | × | × | ○ |
| Tracking hold function during disc defect detection | ○ | ○ | ○ | ○ | ○ |

- Specifications of any and all SANYO products described or contained herein stipulate the performance, characteristics, and functions of the described products in the independent state, and are not guarantees of the performance, characteristics, and functions of the described products as mounted in the customer's products or equipment. To verify symptoms and states that cannot be evaluated in an independent device, the customer should always evaluate and test devices mounted in the customer's products or equipment.
- SANYO Electric Co., Ltd. strives to supply high-quality high-reliability products. However, any and all semiconductor products fail with some probability. It is possible that these probabilistic failures could give rise to accidents or events that could endanger human lives, that could give rise to smoke or fire, or that could cause damage to other property. When designing equipment, adopt safety measures so that these kinds of accidents or events cannot occur. Such measures include but are not limited to protective circuits and error prevention circuits for safe design, redundant design, and structural design.
- In the event that any or all SANYO products(including technical data, services) described or contained herein are controlled under any of applicable local export control laws and regulations, such products must not be exported without obtaining the export license from the authorities concerned in accordance with the above law.
- No part of this publication may be reproduced or transmitted in any form or by any means, electronic or mechanical, including photocopying and recording, or any information storage or retrieval system, or otherwise, without the prior written permission of SANYO Electric Co., Ltd.
- Any and all information described or contained herein are subject to change without notice due to product/technology improvement, etc. When designing equipment, refer to the "Delivery Specification" for the SANYO product that you intend to use.
- Information (including circuit diagrams and circuit parameters) herein is for example only ; it is not guaranteed for volume production. SANYO believes information herein is accurate and reliable, but no guarantees are made or implied regarding its use or any infringements of intellectual property rights or other rights of third parties.

This catalog provides information as of February, 2004. Specifications and information herein are subject to change without notice.