



SANYO Semiconductors

DATA SHEET

An ON Semiconductor Company

LV5681P — Monolithic Linear IC For Car Audio Systems Multi-Power Supply System IC

Overview

The LV5681P is a multi-power supply system IC that provides four regulator outputs and two high side switches as well as a number of protection functions including overcurrent protection, overvoltage protection and overheat protection. It is an optimal power supply IC for car audio and car entertainment systems and similar products.

Features

- Four regulator output systems
 - For microcontroller: 5.7V output voltage, 200mA maximum output current
 - For CD drive: 7.0V output voltage, 1300mA maximum output current
 - For illumination: 8 to 12V output voltage (output can be set with external resistors), 300mA maximum output current
 - For audio systems: 8 to 9V output voltage (output voltage can be set with external resistors), 300mA maximum output current
- Two V_{CC} -linked high side switch systems
 - EXT: 350mA maximum output current, 0.5V voltage difference between input and output.
 - ANT: 300mA maximum output current, 0.5V voltage difference between input and output.
- Two V_{DD} 5V-linked high side switch systems
 - SW5V: 200mA maximum output current, 0.2V voltage difference between input and output.
 - ACC (accessory voltage detection output): 100mA maximum output current, 0.2V voltage difference between input and output.
- Overcurrent protection function
- Overvoltage protection function, typ 21V (excluding V_{DD} 5V output)
- Overheat protection function, typ 175°C
- On-chip accessory voltage detection circuit
- P-channel LDMOS used for power output block

CAUTION)

The protection functions are provided in order to improve the ability of the ICs to withstand breakdown, and they are not intended to guarantee safety when used under conditions outside the safe operating area or rated operating conditions.

Use of the ICs under any conditions exceeding the safe operating area or above the I_{Omax} , and especially use in overcurrent protection areas or under conditions in which they are subject to thermal protection, may reduce their reliability and result in permanent breakdown.

- Any and all SANYO Semiconductor Co.,Ltd. products described or contained herein are, with regard to "standard application", intended for the use as general electronics equipment. The products mentioned herein shall not be intended for use for any "special application" (medical equipment whose purpose is to sustain life, aerospace instrument, nuclear control device, burning appliances, transportation machine, traffic signal system, safety equipment etc.) that shall require extremely high level of reliability and can directly threaten human lives in case of failure or malfunction of the product or may cause harm to human bodies, nor shall they grant any guarantee thereof. If you should intend to use our products for new introduction or other application different from current conditions on the usage of automotive device, communication device, office equipment, industrial equipment etc. , please consult with us about usage condition (temperature, operation time etc.) prior to the intended use. If there is no consultation or inquiry before the intended use, our customer shall be solely responsible for the use.
- Specifications of any and all SANYO Semiconductor Co.,Ltd. products described or contained herein stipulate the performance, characteristics, and functions of the described products in the independent state, and are not guarantees of the performance, characteristics, and functions of the described products as mounted in the customer's products or equipment. To verify symptoms and states that cannot be evaluated in an independent device, the customer should always evaluate and test devices mounted in the customer's products or equipment.

LV5681P

Specifications

Absolute Maximum Ratings at Ta = 25°C

Parameter	Conditions	Conditions	Ratings	Unit	
Supply voltage	V _{CC} max		36	V	
Peak supply voltage	V _{CC} peak	See below for the waveform applied.	50	V	
Allowable Power dissipation	Pd max	Independent IC	Ta ≤ 25°C	1.5	W
		Al heat sink *		5.6	W
		With an infinity heat sink		32.5	W
Junction temperature	Tj max		150	°C	
Operating ambient temperature	Topr		-40 to +85	°C	
Storage temperature	Tstg		-55 to +150	°C	

* : When the Aluminum heat sink (50mm × 50mm × 1.5mm) is used

Allowable Operating range at Ta = 25°C

Parameter	Conditions	Ratings	Unit
Operating supply voltage 1	V _{DD} output, SW output, ACC output	7.5 to 16	V
Operating supply voltage 2	ILM output at 10V	12 to 16	V
	ILM output at 8V	10 to 16	V
Operating supply voltage 3	Audio output at 9V	10 to 16	V
Operating supply voltage 4	CD output (CD output current = 1.3A)	10.5 to 16	V
	CD output (CD output current ≤ 1A)	10 to 16	V

Electrical Characteristics at Ta = 25°C, V_{CC} = 14.4V

*: All the specifications are defined based on the tests that Tj is almost equal to Ta (=25°C). To suppress the rise of Tj in the junction temperature as much as possible, it tests by the pulse loading.

Parameter	Symbol	Conditions	Ratings			Unit
			min	typ	max	
Current drain	I _{CC}	V _{DD} no load, CTRL1/2 = [L/L], ACC = 0V		400	800	μA
CTRL1 Input						
Low input voltage	V _{IL1}		0		0.4	V
M1 input voltage	V _{IM1}		0.8	1.1	1.4	V
M2 input voltage	V _{IM2}		1.9	2.2	2.5	V
High input voltage	V _{IH1}		2.9	3.3	5.5	V
Input impedance	R _{IH1}		350	500	650	kΩ
CTRL2 Input						
Low input voltage	V _{IL2}		0		0.5	V
M input voltage	V _{IM2}		1.1	1.65	2.1	V
High input voltage	V _{IH2}		2.5	3.3	5.5	V
Input impedance	R _{IH2}		350	500	650	kΩ
V_{DD} 5.7V Output *1 The V_{DD} 5.7V output supplies the output currents of SW 5.7V and ACC 5.7V.						
Output voltage 1	V _{O1}	I _{O1} = 200mA, I _{O7} , I _{O8} = 0A	5.4	5.7	6.0	V
Output voltage 2	V _{O1'}	I _{O1} = 200mA, I _{O7} = 200mA, I _{O8} = 100mA	5.4	5.7	6.0	V
Output total current	I _{to1}	V _{O1} ≥ 5.4V, I _{to1} = I _{O1} + I _{O7} + I _{O8}	500			mA
Line regulation	ΔV _{OLN1}	7.5V < V _{CC} < 16V, I _{O1} = 200mA *2		30	90	mV
Load regulation	ΔV _{OLD1}	1mA < I _{O1} < 200mA *2		70	150	mV
Dropout voltage 1	V _{DROP1}	I _{O1} = 200mA *2		1.0	1.5	V
Dropout voltage 2	V _{DROP1'}	I _{O1} = 100mA *2		0.7	1.05	V
Dropout voltage 3	V _{DROP1''}	I _{O1} + I _{O7} + I _{O8} = 500mA		2.5	3.75	V
Ripple rejection	R _{REJ1}	f = 120Hz, I _{O1} = 200mA *2	40	50		dB
CD Output ; CTRL2 = [H]						
Output voltage	V _{O2}	I _{O2} = 1000mA	6.65	7.0	7.35	V

*1 : The V_{DD} 5.7V output also supplies the output currents of SW 5.7V and ACC 5.7V. Therefore, the current supply capability of the V_{DD} 5.7V output and its other electrical characteristics are affected by the output statuses of SW 5.7V and ACC 5.7V.

*2 : SW 5V and ACC 5.7V are not subject to a load.

Continued on next page.

LV5681P

Continued from preceding page.

Parameter	Symbol	Conditions	Ratings			Unit
			min	typ	max	
Output current	I_{O2}	$V_{O2} \geq 6.65V$	1300			mA
Line regulation	ΔV_{OLN2}	$10.5V < V_{CC} < 16V, I_{O2} = 1000mA$		50	100	mV
Load regulation	ΔV_{OLD2}	$10mA < I_{O2} < 1000mA$		100	200	mV
Dropout voltage 1	V_{DROP2}	$I_{O2} = 1000mA$		1.0	1.5	V
Dropout voltage 2	V_{DROP2}'	$I_{O2} = 500mA$		0.5	0.75	V
Ripple rejection	R_{REJ2}	$f = 120Hz, I_{O2} = 1000mA$	40	50		dB
AUDIO (8-9V) Output ; CTRL2 = [M]						
AUDIO_F pin voltage	V_{I3}		1.222	1.260	1.298	V
AUDIO_F pin inflow current	I_{IN3}		-1		1	μA
AUDIO output voltage 1	V_{O3}	$I_{O3} = 200mA, R2 = 30k\Omega, R3 = 5.6k\Omega *3$	7.65	8.0	8.35	V
AUDIO output voltage 2	V_{O3}'	$I_{O3}' = 200mA, R2 = 27k\Omega, R3 = 4.7k\Omega *3$	8.13	8.5	8.87	V
AUDIO output voltage 3	V_{O3}''	$I_{O3}'' = 200mA, R2 = 24k\Omega, R3 = 3.9k\Omega *3$	8.6	9.0	9.4	V
AUDIO output current	I_{O3}		300			mA
Line regulation	ΔV_{OLN3}	$10V < V_{CC} < 16V, I_{O3} = 200mA$		30	90	mV
Load regulation	ΔV_{OLD3}	$1mA < I_{O3} < 200mA$		70	150	mV
Dropout voltage 1	V_{DROP3}	$I_{O3} = 200mA$		0.3	0.45	V
Dropout voltage 2	V_{DROP3}'	$I_{O3} = 100mA$		0.15	0.23	V
Ripple rejection	R_{REJ3}	$f = 120Hz, I_{O3} = 200mA$	40	50		dB
ILM (8-12V) Output ; CTRL1 = [M1]						
ILM_F pin voltage	V_{I4}		1.222	1.260	1.298	V
ILM output voltage 1	V_{O4}	$I_{O4} = 200mA, R2 = 30k\Omega, R3 = 5.6k\Omega *3$	7.65	8.0	8.35	V
ILM output voltage 2	V_{O4}'	$I_{O4}' = 200mA, R2 = 27k\Omega, R3 = 3.9k\Omega *3$	9.55	10.0	10.45	V
ILM output voltage 3	V_{O4}''	$I_{O4}'' = 200mA, R2 = 33k\Omega, R3 = 3.9k\Omega *3$	11.36	11.9	12.44	V
ILM output current	I_{O4}		300			mA
Line regulation	ΔV_{OLN4}	$12V < V_{CC} < 16V, I_{O4} = 200mA$		30	90	mV
Load regulation	ΔV_{OLD4}	$1mA < I_{O4} < 200mA$		70	150	mV
Dropout voltage 1	V_{DROP4}	$I_{O4} = 200mA$		0.7	1.05	V
Dropout voltage 2	V_{DROP4}'	$I_{O4} = 100mA$		0.35	0.53	V
Ripple rejection	R_{REJ4}	$f = 120Hz, I_{O4} = 200mA$	40	50		dB
Remoto (EXT) ; CTRL1 = [M2]						
Output voltage	V_{O5}	$I_{O5} = 350mA$	$V_{CC}-1.0$	$V_{CC}-0.5$		V
Output current	I_{O5}	$V_{O5} \geq V_{CC}-1.0$	350			mA
ANT remoto ; CTRL1 = [H]						
Output voltage	V_{O6}	$I_{O6} = 300mA$	$V_{CC}-1.0$	$V_{CC}-0.5$		V
Output current	I_{O6}	$V_{O6} \geq V_{CC}-1.0$	300			mA
SW 5V Output ; CTRL2 = [M]						
Output voltage 1	V_{O7}	$I_{O7} = 1mA, I_{O1}, I_{O8} = 0A *4$	$V_{O1}-0.25$	V_{O1}		V
Output voltage 2	V_{O7}'	$I_{O7} = 200mA, I_{O1}, I_{O8} = 0A *4$	$V_{O1}-0.45$	$V_{O1}-0.2$		V
Output current	I_{O7}	$V_{O7} \geq 4.55$	200			mA
ACC Detection ; ACC Integration 5V output						
ACC detection voltage	V_{TH8}		2.75	3.0	3.25	V
Hysteresis width	V_{HIS8}		0.2	0.3	0.4	V
Input impedance	Z_{I8}	(Pull-down resistance internal)	42	60	78	$k\Omega$
ACC output voltage 1	V_{O8}	$I_{O8} = 0.5mA, I_{O1}, I_{O7} = 0A *4$	$V_{O1}-0.25$	V_{O1}		V
ACC output voltage 2	V_{O8}'	$I_{O8} = 100mA, I_{O1}, I_{O7} = 0A *4$	$V_{O1}-0.45$	$V_{O1}-0.2$		V
ACC output voltage	I_{O8}	$V_{O8} \geq 4.55$	100			mA

*3 : When a component with a resistance accuracy of $\pm 1\%$ is used

<Reference> When a component with a resistance accuracy of $\pm 0.5\%$ is used, V_{O3}'' is $8.67V \leq 9.0V \leq 9.33V$.

*4 : Since the SW 5.7V and ACC 5.7V are output from V_{DD} 5.7V through the SW, the voltage drops by an amount equivalent to the ON resistance of the SW.

LV5681P

Package Dimensions

unit : mm (typ)
3395

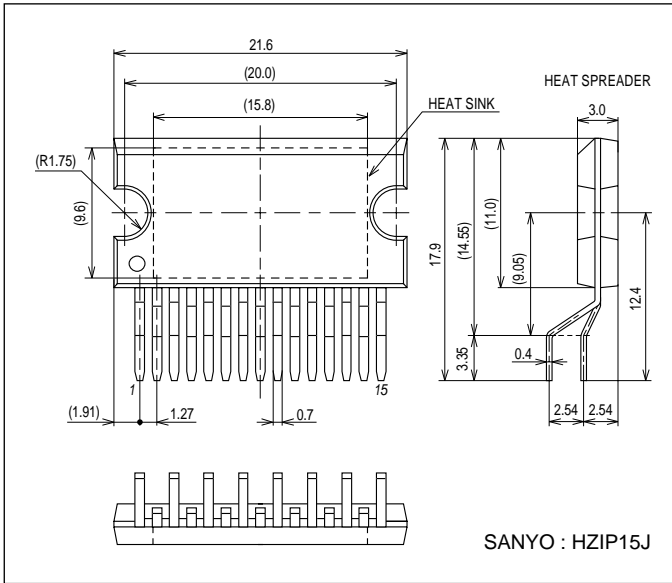

• Allowable power dissipation derating curve

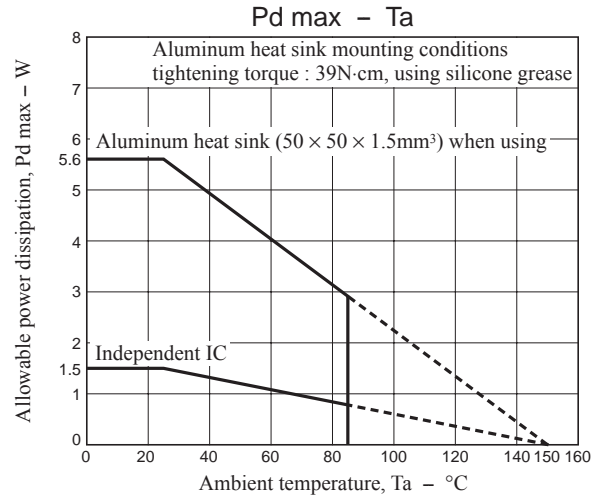

• Waveform applied during surge test

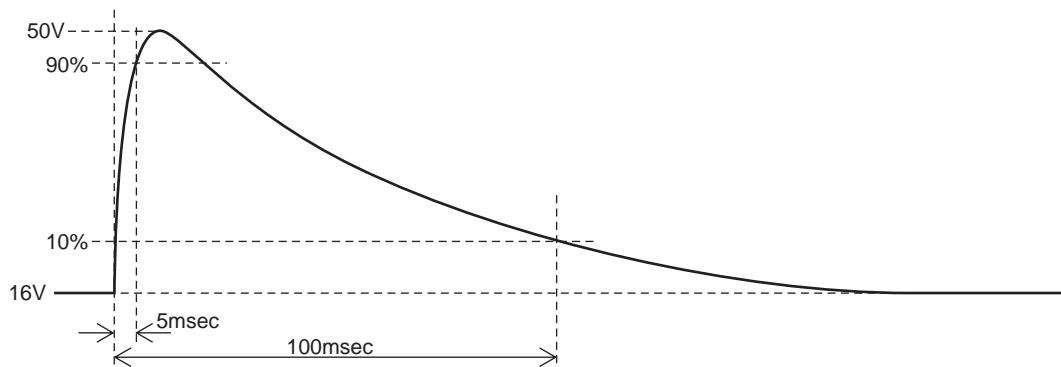

LV5681P

Block Diagram

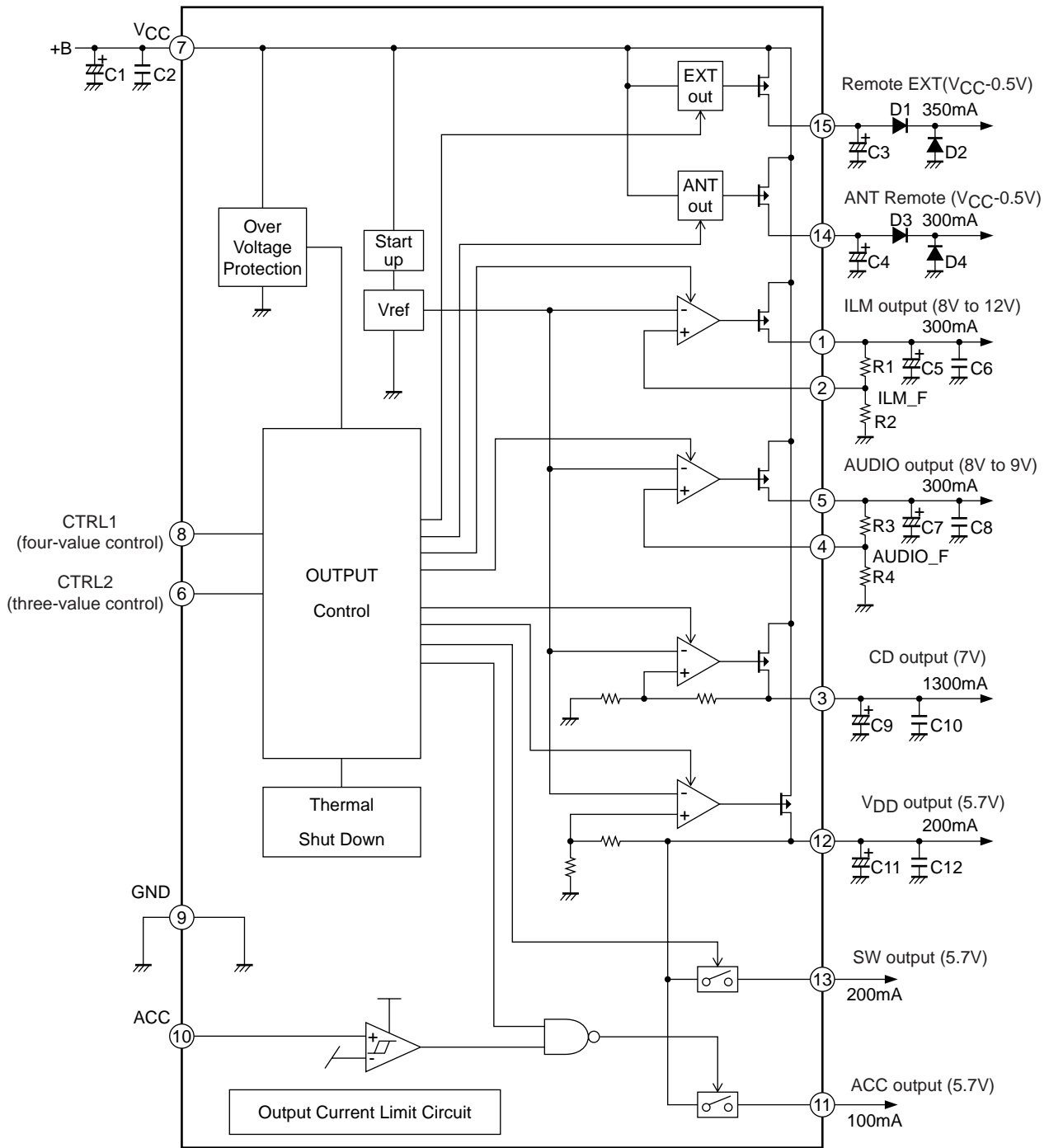

Pin Function

Pin No.	Pin name	Description	Equivalent Circuit
1	ILM	ILM output pin ON when CTRL1 = M1, M2, H 8.0 to 12.0V/300mA	
2	ILM_F	ILM output voltage adjustment pin	

Continued on next page.

LV5681P

Continued from preceding page.

Pin No.	Pin name	Description	Equivalent Circuit
3	CD	CD output pin ON when CTRL2 = M, H 7.0V/1.3A	
4	AUDIO_F	AUDIO output voltage adjustment pin	
5	AUDIO	AUDIO output pin ON when CTRL2 = M, H 8.0 to 9.0V/300mA	
6	CTRL2	CTRL2 input pin three-value input	
7	VCC	Supply terminal	
8	CTRL1	CTRL1 input pin four-value input	
9	GND	GND pin	

Continued on next page.

LV5681P

Continued from preceding page.

Pin No.	Pin name	Description	Equivalent Circuit
10	ACC	Accessory input	
11	ACC5V	Accessory detection output ON when ACC > 3V	
12	V _{DD} 5V	V _{DD} 5.7V output pin 5.7V/500mA	
13	SW5V	SW5.7V output pin ON when CTRL2 = M, H	
14	ANT	ANT output pin ON when CTRL1 = H V _{CC} -0.5V/300mA	
15	EXT	EXT output pin ON when CTRL1 = M2, H V _{CC} -0.5V/350mA	

LV5681P

CTRL Pin Output Truth Table

CTRL1	ANT	EXT	ILM
L	OFF	OFF	OFF
M1	OFF	OFF	ON
M2	OFF	ON	ON
H	ON	ON	ON

CTRL2	CD	AUDIO	SW5
L	OFF	OFF	OFF
M	OFF	ON	ON
H	ON	ON	ON

Timing Chart

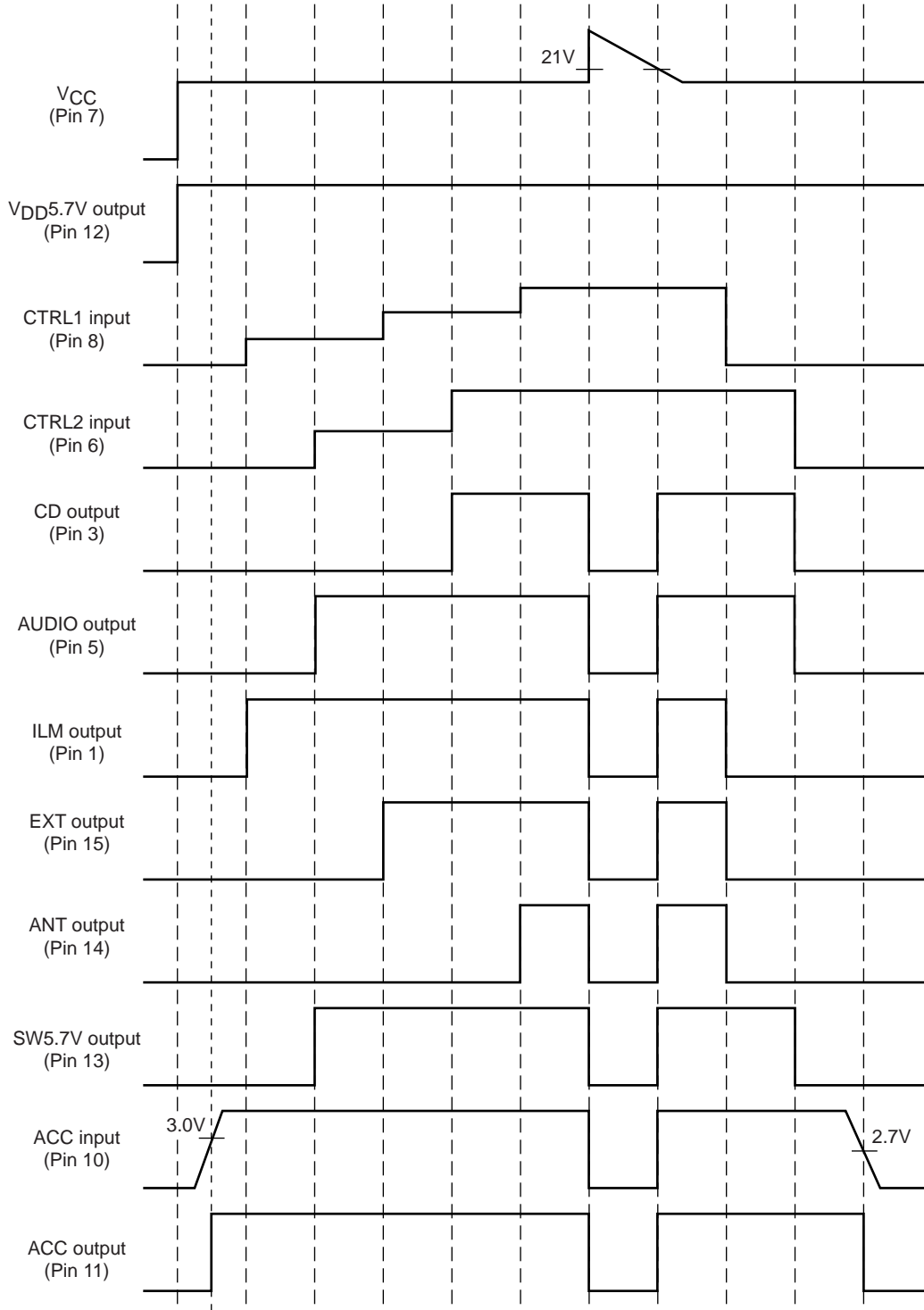

LV5681P

Recommended Operation Circuit

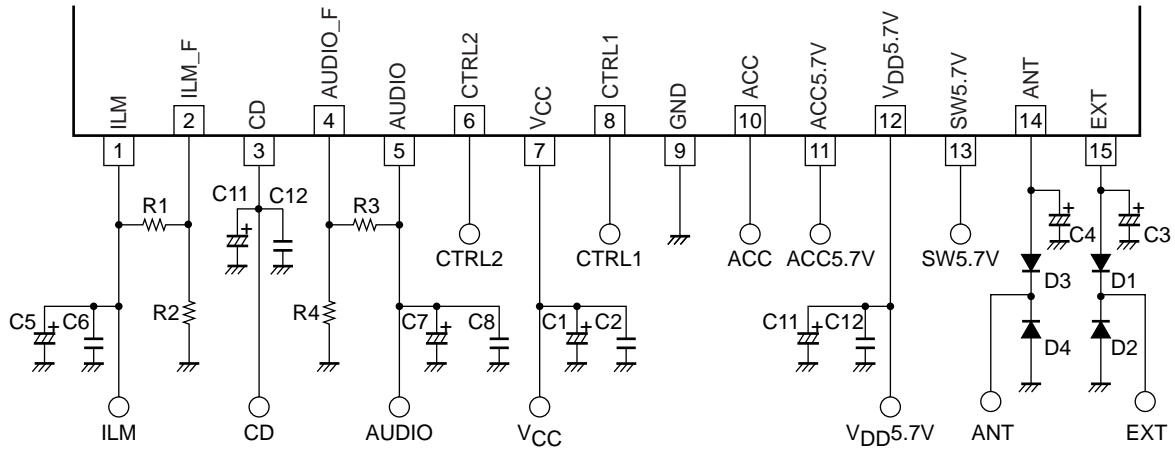

Peripheral parts list

Name of part	Description	Recommended value	Remarks
C1	Power supply bypass capacitor	100 μ F or more	These capacitors must be placed near the V _{CC} and GND pins.
C2	Oscillation prevention capacitor	0.22 μ F or more	
C3	EXT output stabilization capacitor	2.2 μ F or more	
C4	ANT output stabilization capacitor	2.2 μ F or more	
C5, C57 C9, C11	Output stabilization capacitor	4.7 μ F or more	Electrolytic capacitor *
C6, C8, C10, C12	Output stabilization capacitor	0.22 μ F or more	Ceramic capacitor *
R1,R2	Resistor for ILM voltage adjustment	R1/R2 :30k Ω /5.6k Ω = 8.0V :27k Ω /3.9k Ω = 10.0V :33k Ω /3.9k Ω = 11.9V	A resistor with resistance accuracy as low as less than $\pm 1\%$ must be used.
R3, R4	Resistor for AUDIO voltage setting	R3/R4 :30k Ω /5.6k Ω = 8.0V :27k Ω /4.7k Ω = 8.5V :24k Ω /3.9k Ω = 9.0V	A resistor with resistance accuracy as low as less than $\pm 1\%$ must be used.
D1, D2, D3, D4	Diode for internal device breakdown protection		

* : In order to stabilize the regulator outputs, it is recommended that the electrolytic capacitor and ceramic capacitor be connected in parallel.

Furthermore, the values listed above do not guarantee stabilization during the overcurrent protection operations of the regulator, so oscillation may occur during an overcurrent protection operation.

• AUDIO/ILM output voltage setting method

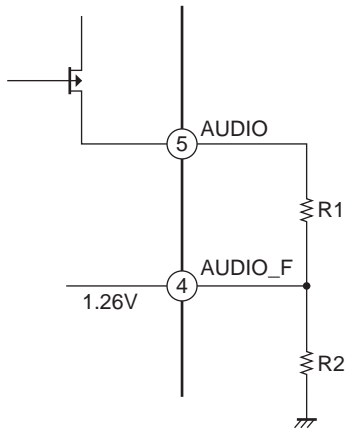

The AUDIO_F voltage is determined by the internal band gap voltage of the IC (typ = 1.26V).

Formula for AUDIO voltage calculation

$$AUDIO = \frac{1.26[V]}{R_2} \times R_1 + 1.26[V]$$

$$\frac{R_1}{R_2} = \frac{(AUDIO - 1.26)}{1.26}$$

The circuit must be designed in such a way that the R1:R2 ratio satisfies the formula given above for the AUDIO voltage that has been set.

Example : AUDIO = 8.5V setting method

$$\frac{R_1}{R_2} = \frac{(8.5 - 1.26)}{1.26} \cong 5.75$$

$$\frac{R_1}{R_2} = \frac{27k\Omega}{4.7k\Omega} \cong 5.74$$

$$AUDIO = 1.26V \times 5.74 + 1.26V \cong \boxed{8.49V}$$

The ILM output voltage can be set by the above-mentioned method.

Note : In the above, the typical values are given in all instances for the values used and, as such, they will vary due to the effects of production-related variations of the IC and external resistors.

LV5681P

• CTRL1 Application Circuit Example

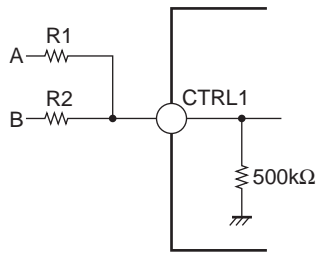

(1) 3.3V input: $R1 = 4.7k\Omega$, $R2 = 10k\Omega$

A	B	CTRL1
0V	0V	0V
0V	3.3V	1.05V
3.3V	0V	2.23V
3.3V	3.3V	3.20V

• CTRL2 Application Circuit Example

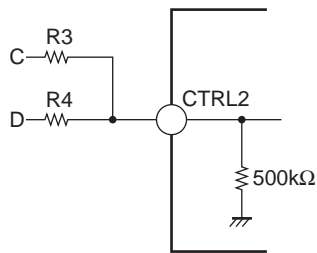

(1) 3.3V input: $R3 = R4 = 4.7k\Omega$

A	B	CTRL2
0V	0V	0V
0V	3.3V	1.61V
3.3V	0V	1.61V
3.3V	3.3V	3.29V

Caution for implementing LV5681P to a system board

In HZIP15J, the package used in this IC, there are several metal exposure other than the connection pins and heat-sinks as shown in the following diagrams. In the diagrams, the electric potential of 2 and 3 are the same as Pin15 and Pin1, respectively. 2 (=Pin15) is EXT pin and 3 (=Pin1) is ILM output (regulator). When the IC is implemented to the system, make sure that no attachment clamp touches the exposed Pin1/ Pin15. When the exposed Pin1/ Pin15 touch the attachment clamp (same electrical potential as GND), ILM output or VCC enter the same state as time when GND was shorted. The electric potential of the exposed metal connected to heat-sinks 1 is the same as that of sub board of the IC (GND). Therefore, even if the exposed metal and GND of the system board are adjacent to each other, there should be no problem.

• HZIP15J external view

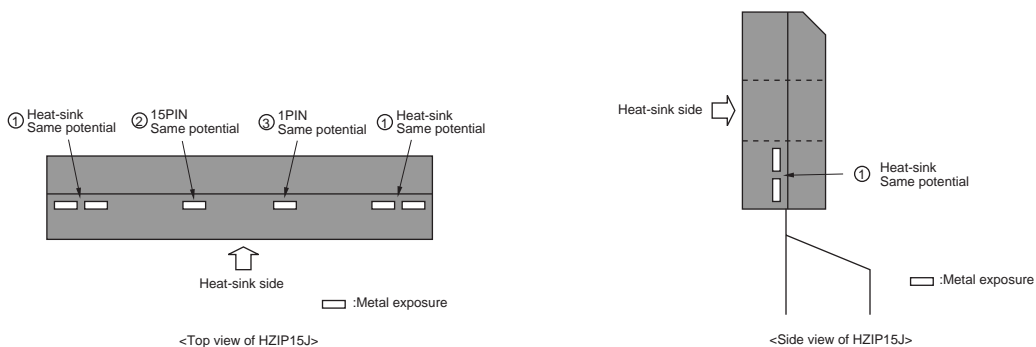

LV5681P

- Frame diagram (LV5681P) *In the system power supply other than LV5681P, pin assignment may differ.

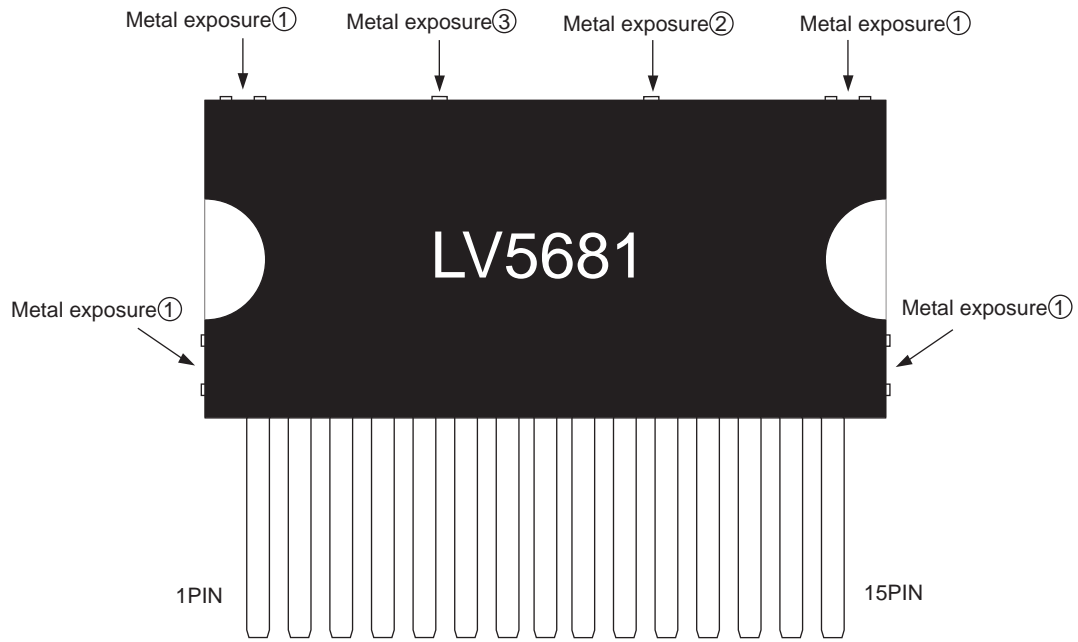

HZIP15J Heat sink attachment

Heat sinks are used to lower the semiconductor device junction temperature by leading the heat generated by the device to the outer environment and dissipating that heat.

- a. Unless otherwise specified, for power ICs with tabs and power ICs with attached heat sinks, solder must not be applied to the heat sink or tabs.

b. Heat sink attachment

- Use flat-head screws to attach heat sinks.
- Use also washer to protect the package.
- Use tightening torques in the ranges 39-59Ncm(4-6kgcm) .
- If tapping screws are used, do not use screws with a diameter larger than the holes in the semiconductor device itself.
- Do not make gap, dust, or other contaminants to get between the semiconductor device and the tab or heat sink.
- Take care a position of via hole .
- Do not allow dirt, dust, or other contaminants to get between the semiconductor device and the tab or heat sink.
- Verify that there are no press burrs or screw-hole burrs on the heat sink.
- Warping in heat sinks and printed circuit boards must be no more than 0.05 mm between screw holes, for either concave or convex warping.
- Twisting must be limited to under 0.05 mm.
- Heat sink and semiconductor device are mounted in parallel.
Take care of electric or compressed air drivers
- The speed of these torque wrenches should never exceed 700 rpm, and should typically be about 400 rpm.

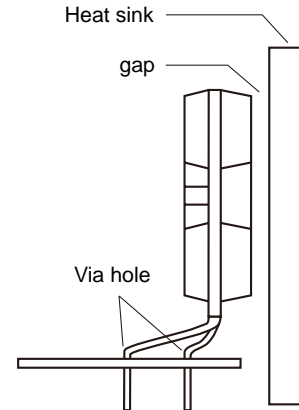
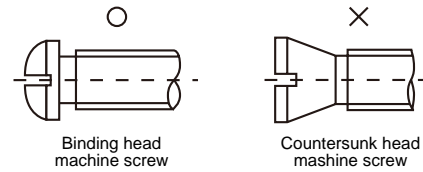

c. Silicone grease

- Spread the silicone grease evenly when mounting heat sinks.
- Sanyo recommends YG-6260 (Momentive Performance Materials Japan LLC)

d. Mount

- First mount the heat sink on the semiconductor device, and then mount that assembly on the printed circuit board.
- When attaching a heat sink after mounting a semiconductor device into the printed circuit board, when tightening up a heat sink with the screw, the mechanical stress which is impossible to the semiconductor device and the pin doesn't hang.

e. When mounting the semiconductor device to the heat sink using jigs, etc.,

- Take care not to allow the device to ride onto the jig or positioning dowel.
- Design the jig so that no unreasonable mechanical stress is not applied to the semiconductor device.

f. Heat sink screw holes

- Be sure that chamfering and shear drop of heat sinks must not be larger than the diameter of screw head used.
- When using nuts, do not make the heat sink hole diameters larger than the diameter of the head of the screws used. A hole diameter about 15% larger than the diameter of the screw is desirable.
- When tap screws are used, be sure that the diameter of the holes in the heat sink are not too small. A diameter about 15% smaller than the diameter of the screw is desirable.

- g. There is a method to mount the semiconductor device to the heat sink by using a spring band. But this method is not recommended because of possible displacement due to fluctuation of the spring force with time or vibration.

- SANYO Semiconductor Co.,Ltd. assumes no responsibility for equipment failures that result from using products at values that exceed, even momentarily, rated values (such as maximum ratings, operating condition ranges, or other parameters) listed in products specifications of any and all SANYO Semiconductor Co.,Ltd. products described or contained herein.
- SANYO Semiconductor Co.,Ltd. strives to supply high-quality high-reliability products, however, any and all semiconductor products fail or malfunction with some probability. It is possible that these probabilistic failures or malfunction could give rise to accidents or events that could endanger human lives, trouble that could give rise to smoke or fire, or accidents that could cause damage to other property. When designing equipment, adopt safety measures so that these kinds of accidents or events cannot occur. Such measures include but are not limited to protective circuits and error prevention circuits for safe design, redundant design, and structural design.
- In the event that any or all SANYO Semiconductor Co.,Ltd. products described or contained herein are controlled under any of applicable local export control laws and regulations, such products may require the export license from the authorities concerned in accordance with the above law.
- No part of this publication may be reproduced or transmitted in any form or by any means, electronic or mechanical, including photocopying and recording, or any information storage or retrieval system, or otherwise, without the prior written consent of SANYO Semiconductor Co.,Ltd.
- Any and all information described or contained herein are subject to change without notice due to product/technology improvement, etc. When designing equipment, refer to the "Delivery Specification" for the SANYO Semiconductor Co.,Ltd. product that you intend to use.
- Upon using the technical information or products described herein, neither warranty nor license shall be granted with regard to intellectual property rights or any other rights of SANYO Semiconductor Co.,Ltd. or any third party. SANYO Semiconductor Co.,Ltd. shall not be liable for any claim or suits with regard to a third party's intellectual property rights which has resulted from the use of the technical information and products mentioned above.

This catalog provides information as of October, 2011. Specifications and information herein are subject to change without notice.