



SANYO Semiconductors

# DATA SHEET

An ON Semiconductor Company

## LV8401V — Bi-CMOS IC Forward/Reverse Motor Driver

### Overview

The LV8401V is a 1-channel motor driver IC using D-MOS FET for output stage and operates in one of the four modes under program control: forward, reverse, brake, and standby.

As the P/N-channel structure is used in the H-bridge output stage, the LV8401V features minimal number of external component and low on-resistance ( $0.33\Omega$  typical). This IC is optimal for driving motors that need large-current.

### Functions

- 1-channel forward/reverse motor driver
- Low power consumption
- Low output ON resistance  $0.33\Omega$
- Built-in constant current output circuit
- Built-in low voltage reset and thermal shutdown circuit
- Four mode function forward/reverse, brake, standby.

### Specifications

**Maximum Ratings** at  $T_a = 25^\circ\text{C}$ ,  $\text{SGND} = \text{PGND} = 0\text{V}$

Parameter	Symbol	Conditions	Ratings	Unit
Power supply voltage (for load)	$V_M$ max		-0.5 to 16.0	V
Power supply voltage (for control)	$V_{CC}$ max		-0.5 to 6.0	V
Output current	$I_O$ max	DC	1.2	A
	$I_O$ peak1	$t \leq 100\text{ms}$ , $f = 5\text{Hz}$	2.0	A
	$I_O$ peak2	$t \leq 10\text{ms}$ , $f = 5\text{Hz}$	3.8	A
	$I_{OUT}$ max	DC	30	mA
Input voltage	$V_{IN}$ max		-0.5 to $V_{CC}+0.5$	V
Allowable power dissipation	$P_d$ max	Mounted on a specified board *	800	mW
Operating temperature	$T_{opr}$		-20 to +75	$^\circ\text{C}$
Storage temperature	$T_{stg}$		-55 to +150	$^\circ\text{C}$

\* Specified board : 30mm × 50mm × 1.6mm, glass epoxy board.

■ Any and all SANYO Semiconductor Co.,Ltd. products described or contained herein are, with regard to "standard application", intended for the use as general electronics equipment (home appliances, AV equipment, communication device, office equipment, industrial equipment etc.). The products mentioned herein shall not be intended for use for any "special application" (medical equipment whose purpose is to sustain life, aerospace instrument, nuclear control device, burning appliances, transportation machine, traffic signal system, safety equipment etc.) that shall require extremely high level of reliability and can directly threaten human lives in case of failure or malfunction of the product or may cause harm to human bodies, nor shall they grant any guarantee thereof. If you should intend to use our products for applications outside the standard applications of our customer who is considering such use and/or outside the scope of our intended standard applications, please consult with us prior to the intended use. If there is no consultation or inquiry before the intended use, our customer shall be solely responsible for the use.

■ Specifications of any and all SANYO Semiconductor Co.,Ltd. products described or contained herein stipulate the performance, characteristics, and functions of the described products in the independent state, and are not guarantees of the performance, characteristics, and functions of the described products as mounted in the customer's products or equipment. To verify symptoms and states that cannot be evaluated in an independent device, the customer should always evaluate and test devices mounted in the customer's products or equipment.

**SANYO Semiconductor Co., Ltd.**

[www.semiconductor-sanyo.com/network](http://www.semiconductor-sanyo.com/network)

# LV8401V

## Allowable Operating Conditions at $T_a = 25^\circ\text{C}$ , $\text{SGND} = \text{PGND} = 0\text{V}$

Parameter	Symbol	Conditions	Ratings	Unit
Power supply voltage (for load)	VM		4.0 to 15.0	V
Power supply voltage (for control)	V <sub>CC</sub>		2.7 to 5.5	V
Input signal voltage	V <sub>IN</sub>		0 to V <sub>CC</sub>	V
Input signal frequency	f max	Duty = 50%	200	kHz

## Electrical Characteristics $T_a = 25^\circ\text{C}$ , $V_{CC} = 5.0\text{V}$ , $V_M = 12.0\text{V}$ , $\text{SGND} = \text{PGND} = 0\text{V}$ , unless otherwise specified.

Parameter	Symbol	Conditions	Remarks	Ratings			Unit
				min	typ	max	
Standby load current drain 1	IMO1	EN = 0V	1			1.0	μA
Standby load current drain 2	IMO2	EN = 0V, V <sub>CC</sub> = 0V, Each input pin = 0V	1			1.0	μA
Standby control current drain	ICO	EN = 0V, IN1 = IN2 = 0V	2	12.5	25	50	μA
Operating load current drain 1	IM1	V <sub>CC</sub> = 3.3V, EN = 3.3V	3		0.35	0.70	mA
Operating load current drain 2	IM2	V <sub>CC</sub> = 5.0V, EN = 5.0V	3		0.35	0.70	mA
Operating current consumption 1	IC1	V <sub>CC</sub> = 3.3V, EN = 3.3V	4		0.6	1.2	mA
Operating current consumption 2	IC2	V <sub>CC</sub> = 5.0V, EN = 5.0V	4		0.8	1.6	mA
High-level input voltage	V <sub>IH</sub>	$2.7 \leq V_{CC} \leq 5.5\text{V}$		$0.6 \times V_{CC}$		V <sub>CC</sub>	V
Low-level input voltage	V <sub>IL</sub>	$2.7 \leq V_{CC} \leq 5.5\text{V}$		0		$0.2 \times V_{CC}$	V
High-level input current (IN1, IN2, ICTRL)	I <sub>IH</sub>	V <sub>IN</sub> = 5.0V	5	12.5	25	50	μA
Low-level input current (IN1, IN2, ICTRL)	I <sub>IL</sub>	V <sub>IN</sub> = 0V	5	-1.0			μA
Pull-up resistance value (EN)	R <sub>UP</sub>			100	200	400	kΩ
Pull-down resistance value (IN1, IN2, ICTRL)	R <sub>DN</sub>			100	200	400	kΩ
Output ON resistance	R <sub>ON</sub>	Sum of top and bottom sides ON resistance. $2.7\text{V} \leq V_{CC} \leq 5.5\text{V}$	6		0.33	0.5	Ω
Constant current output leakage current	I <sub>O</sub> LEAK	EN = 0V	7			1.0	μA
Output constant current	I <sub>OUT</sub>	RSET = 40Ω, Internal reference = 0.2V	8	4.65	5.00	5.35	mA
ISET pin voltage	V <sub>ISET</sub>	RSET = 40Ω	9	0.186	0.20	0.214	V
Constant current output ON resistance	R <sub>ON</sub> I <sub>O</sub>	RSET = 0Ω, I <sub>O</sub> = 5mA	10		20	30	Ω
Low-voltage detection voltage	VCS	V <sub>CC</sub> voltage	11	2.10	2.25	2.40	V
Thermal shutdown temperature	T <sub>th</sub>	Design guarantee *	12	150	180	210	°C
Output block	Turn-on time	TPLH	13		0.5	1.0	μs
	Turn-off time	TPHL	13		0.5	1.0	μs

\* Design guarantee value and no measurement is performed.

### Remarks

1. Current consumption when output at the VM pin is off.
2. Current consumption at the V<sub>CC</sub> pin when in all function stop mode.
3. Current consumption at the VM pin when EN is high.
4. Current consumption at the V<sub>CC</sub> pin when EN is high.
5. These input pins (IN1, IN2, and ICTRL) have an internal pull-down resistor and the EN pin an internal pull-up resistor.
6. Sum of the top and bottom side output on resistance.
7. Leakage current when the constant current output is off.
8. Current value that is determined by dividing the internal reference voltage (0.2V) by RSET.
9. ISET pin voltage when the constant current output block is active.
10. ON resistance value of the constant current output block.
11. All output transistors are turned off if a low-voltage is detected.
12. All output transistors are turned off if the thermal protection circuit is activated. They are turned on again as the temperature goes down.
13. Rising time from 10 to 90% and falling time from 90 to 10% are specified.

# LV8401V

## Package Dimensions

unit : mm (typ)

3178B

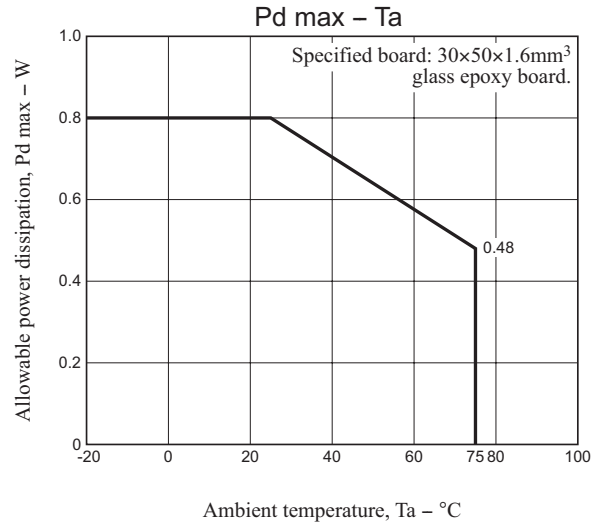
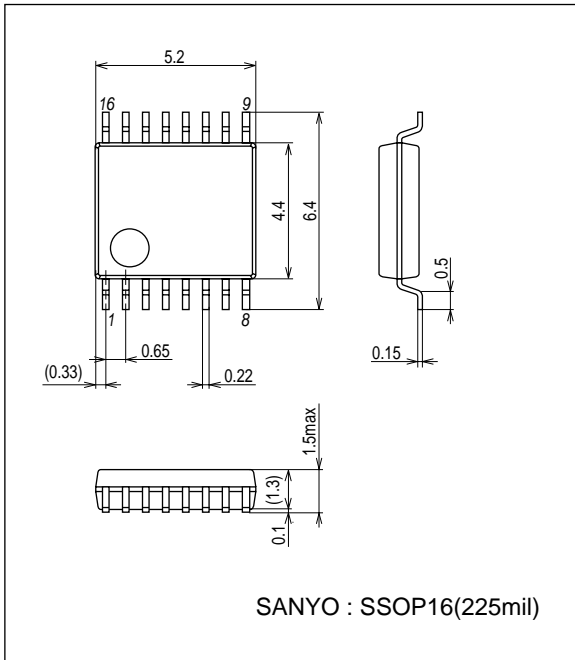

## Pin Assignment

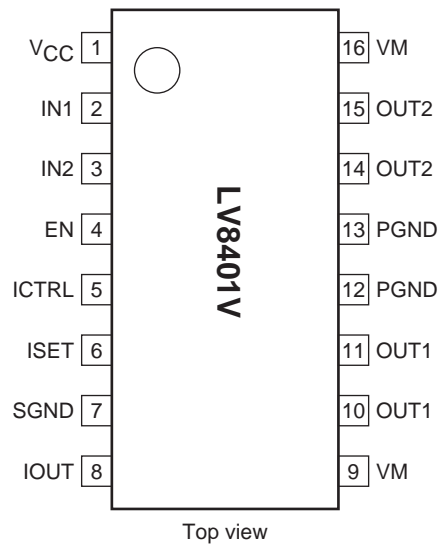

# LV8401V

## Block Diagram

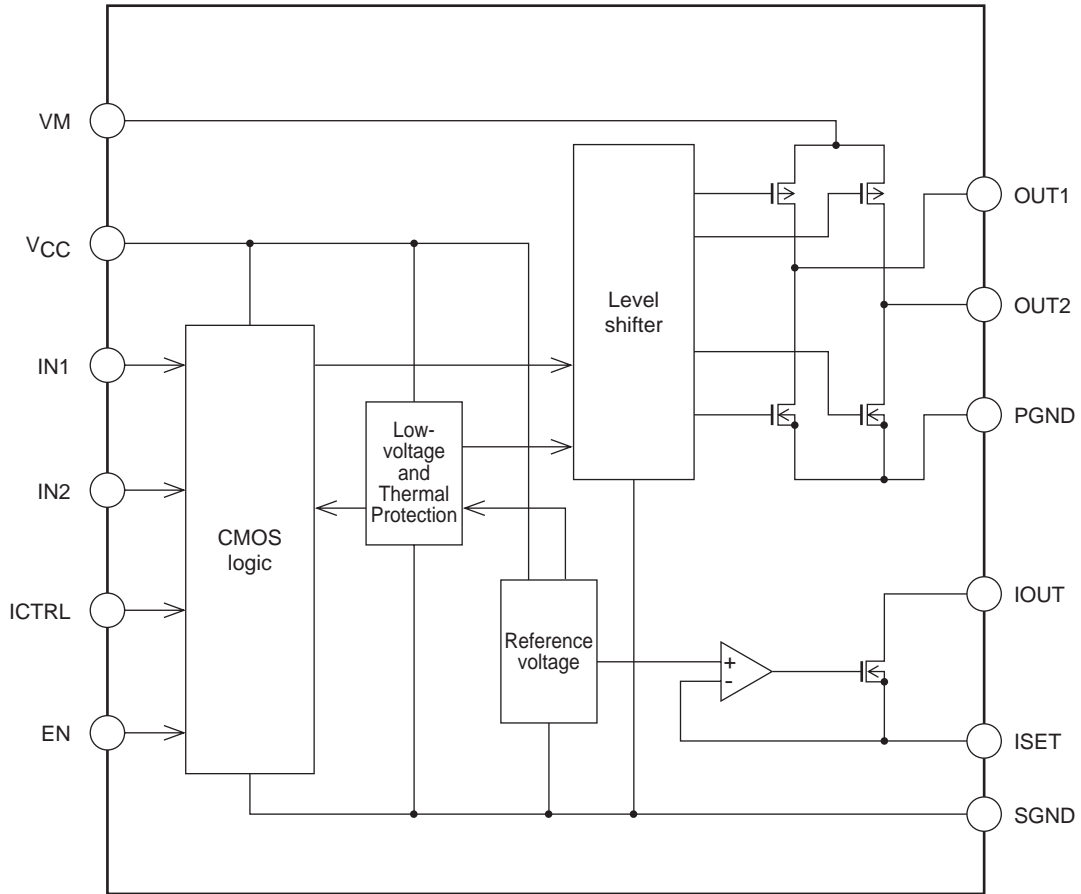

## Truth Table

EN	IN1	IN2	OUT1	OUT2	Mode
H	H	H	L	L	Brake
	H	L	H	L	Forward
	L	H	L	H	Reverse
	L	L	Z	Z	Standby
L	-	-	Z	Z	All function stop

EN	ICTRL	IOUT	Mode
H	H	ON	Constant current ON
	L	Z	Constant current OFF
L	-	Z	All function stop

- : denotes a don't care value. Z : High-impedance

- Current drain is zero in all function stop mode. (excluding the current that flows out of the EN pin)
- \* All power transistors turn off and the motor stops driving when the IC is detected in low voltage or thermal protection mode.

# LV8401V

## Pin Functions

Pin No.	Pin name	Description	Equivalent circuit
9 16	VM	Motor block power supply. (Both pins must be connected)	
1	VCC	Logic block power supply.	
4	EN	Logic enable pin. (Pull-up resistor incorporated)	
2 3 5	IN1 IN2 ICTRL	Driver output switching. (Pull-down resistor incorporated)	
10 11 14 15	OUT1 OUT2	Driver output.	
6 8	ISET IOUT	Constant current output.	
7	SGND	Logic block ground.	
12 13	PGND	Driver block ground. (Both pins must be connected)	

## Sample Application Circuit

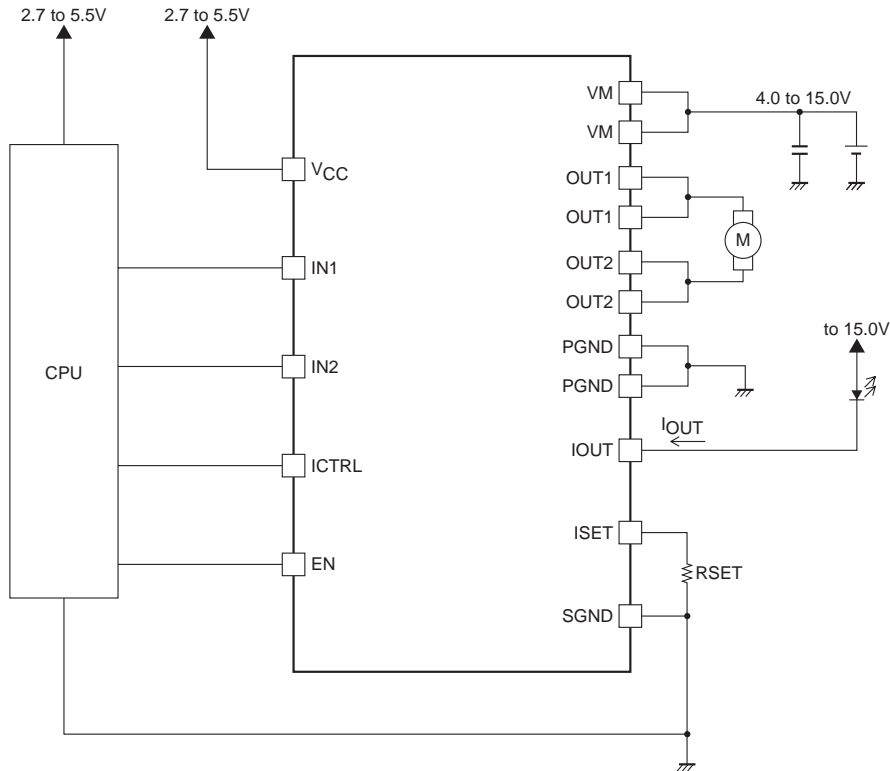

- \*1 : Connect a kickback absorbing capacitor as close as possible to the IC. Characteristics deterioration of the IC or damage may result if an instantaneous voltage surge exceeding the maximum rated value is applied to the VM line due to coil kickback or other causes.
- \*2 : The output constant current ( $I_{OUT}$ ) is determined by the internal reference voltage and the sense resistor between the ISET and SGND pins.
- $$I_{OUT} = \text{Internal reference voltage (0.2V)} \div \text{Sense resistor (RSET)}$$

From the formula above,  $I_{OUT} = 5\text{mA}$  when a sense resistor of  $40\Omega$  is connected between the ISET and SGND.

- SANYO Semiconductor Co.,Ltd. assumes no responsibility for equipment failures that result from using products at values that exceed, even momentarily, rated values (such as maximum ratings, operating condition ranges, or other parameters) listed in products specifications of any and all SANYO Semiconductor Co.,Ltd. products described or contained herein.
- SANYO Semiconductor Co.,Ltd. strives to supply high-quality high-reliability products, however, any and all semiconductor products fail or malfunction with some probability. It is possible that these probabilistic failures or malfunction could give rise to accidents or events that could endanger human lives, trouble that could give rise to smoke or fire, or accidents that could cause damage to other property. When designing equipment, adopt safety measures so that these kinds of accidents or events cannot occur. Such measures include but are not limited to protective circuits and error prevention circuits for safe design, redundant design, and structural design.
- In the event that any or all SANYO Semiconductor Co.,Ltd. products described or contained herein are controlled under any of applicable local export control laws and regulations, such products may require the export license from the authorities concerned in accordance with the above law.
- No part of this publication may be reproduced or transmitted in any form or by any means, electronic or mechanical, including photocopying and recording, or any information storage or retrieval system, or otherwise, without the prior written consent of SANYO Semiconductor Co.,Ltd.
- Any and all information described or contained herein are subject to change without notice due to product/technology improvement, etc. When designing equipment, refer to the "Delivery Specification" for the SANYO Semiconductor Co.,Ltd. product that you intend to use.
- Information (including circuit diagrams and circuit parameters) herein is for example only; it is not guaranteed for volume production.
- Upon using the technical information or products described herein, neither warranty nor license shall be granted with regard to intellectual property rights or any other rights of SANYO Semiconductor Co.,Ltd. or any third party. SANYO Semiconductor Co.,Ltd. shall not be liable for any claim or suits with regard to a third party's intellectual property rights which has resulted from the use of the technical information and products mentioned above.

This catalog provides information as of December, 2008. Specifications and information herein are subject to change without notice.