

Product Specifications

Customer	
Description	7" TFT LCD Module
Model Name	LW700AT9603
Date	2008/09/17
Doc. No.	
Revision	02

Customer Approval	
Date	
The above signature represents that the product specifications, testing regulation, and warranty in the specifications are accepted	

Engineering			
Check	Date	Prepared	Date
		<i>Simon Yang</i>	2008.09.09

Brief Spec

CONTENTS

No.	ITEM	PAGE
0	RECORD OF REVISION	3
1	SUMMARY	4
2	FEATURES	4
3	GENERAL SPECIFICATIONS	4
4	ABSOLUTE MAXIMUM RATINGS	4
5	ELECTRICAL CHARACTERISTICS	5
6	AC CHARACTERISTICS	6~7
7	OPTICAL CHARATERISTIC	8~10
8	TOUCH PANEL	11
9	INTERFACE	12
10	BLOCK DIAGRAM	13
11	QUALITY ASSURANCE	13
12	OUTLINE DRAWING	15
13	PACKAGE INFORMATION	16
14	PRECAUTIONS	16~17

Brief Spec

CONFIDENTIAL-FOR REVIEW ONLY

1. SUMMARY

This technical specification applies to 7" TFT-LCD module with a touch panel and a 40-pin TTL interface. This module supports 800*R.G.B x 480 WVGA mode and can display 262,144 colors.

2. FEATURES

- Thin and Light Weight.
- WVGA(800x480 pixels) resolution.
- 3.3 V TTL interface

3. GENERAL SPECIFICATIONS

Parameter	Specifications	Unit
Screen size	7"(Diagonal)	inch
Display Format	800 RGB x 480	Dot
Active area	152.4x91.44	mm
Pixel size	190.5 x 190.5	um
Surface treatment	Anti-glare	
Pixel Configuration	RGB Vertical Stripe	
Outline dimension	165(W) x 104.44(H) x 6.59 (D)	mm
Weight	123	g
View Angle direction	6 o'clock	
Temperature Range	Storage	-30~80
		°C

Brief Spec

4. ABSOLUTE MAXIMUM RATINGS (GND=0V)

Item	Symbol	Condition	Min.	Max.	Unit	Remark
Power Voltage	Vcc	GND=0	-0.3	6	V	-
Input logic voltage	Vi	GND=0	-0.3	Vcc+0.3	V	Note 1

Note 1: DCLK, DE, R0~ R5, G0~ G5, B0~ B5.

5. ELECTRICAL CHARACTERISTICS

5.1 Recommended Operation condition (GND=0V , Ta=25°C)

Parameter	Symbol	Rating			Unit	Condition	
		Min.	Typ.	Max.			
Power Supply Voltage	V _{CC}	3.0	3.3	3.6	V		
Input logic voltage	High Level	V _{IH}	0.7V _{CC}	-	V _{CC}	V	Note 1
	Low Level	V _{IL}	0	-	0.3V _{CC}	V	Note 1

Note 1: DCLK, DE, R0~ R5, G0~ G5, B0~ B5.

5.2 LED Driving Conditions

Parameter	Symbol	Min.	Typ.	Max.	Unit	Remark
LED current	I _{LED}	-	160	-	mA	Note 1
LED voltage	V _{LED}	-	9.9	-	V	
LED Life Time	-	10,000	20,000	-	Hr	Note 2

Note 1 : There are 8 Groups LED shown as below , V_{LED}=9.9V , I_{LED}=160mA.

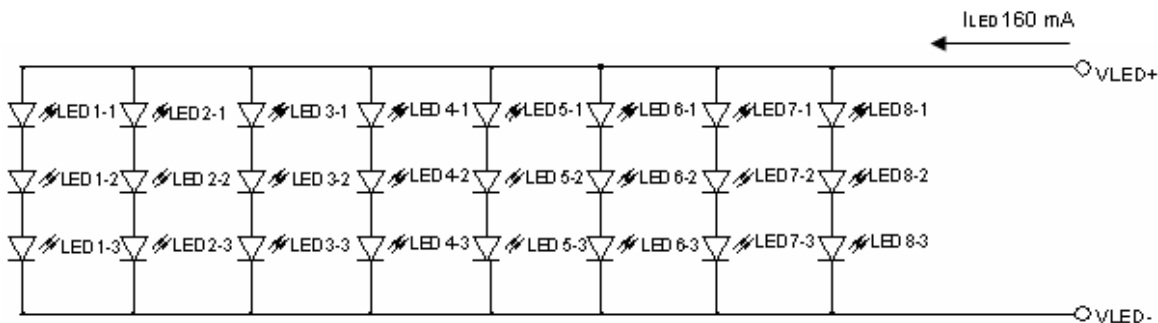

Note 2 : Brightness to be decreased to 50% of the initial value.

5.3 TFT-LCD current consumption

Parameter	Symbol	Rating			Unit	Condition
		Min.	Typ.	Max.		
LCD power current	I _{CC}	--	150	200	mA	black pattern
LED power current	I _{LED}	--	160	200	mA	

Brief Summary

6. AC CHARACTERISTICS

6.1 AC Electrical CHARACTERISTICS

Parameter	Symbol	Rating			Unit
		Min.	Typ.	Max.	
Data setup time	Tdsu	6	-	-	ns
Data hold time	Tdhd	6	-	-	Tcph
DE setup time	Tesu	6	-	-	Tcph
CLK frequency	F _{CPH}		33.26		MHz
CLK period	T _{CPH}	20	30.06	50	ns
CLK pulse duty	T _{CWH}	40	50	60	%
DE period	T _{DEH} +T _{DEL}	1000	1056	1200	T _{CPH}
DE pulse width	T _{DEH}	-	800	-	T _{CPH}
DE frame blanking	T _{DEB}	10	45	110	T _{DEH} +T _{DEL}
DE frame width	T _{DE}	-	480	-	T _{DEH} +T _{DEL}

Brief Spec

6.2 Timing Controller Timing Chart

Clock and Data input waveforms

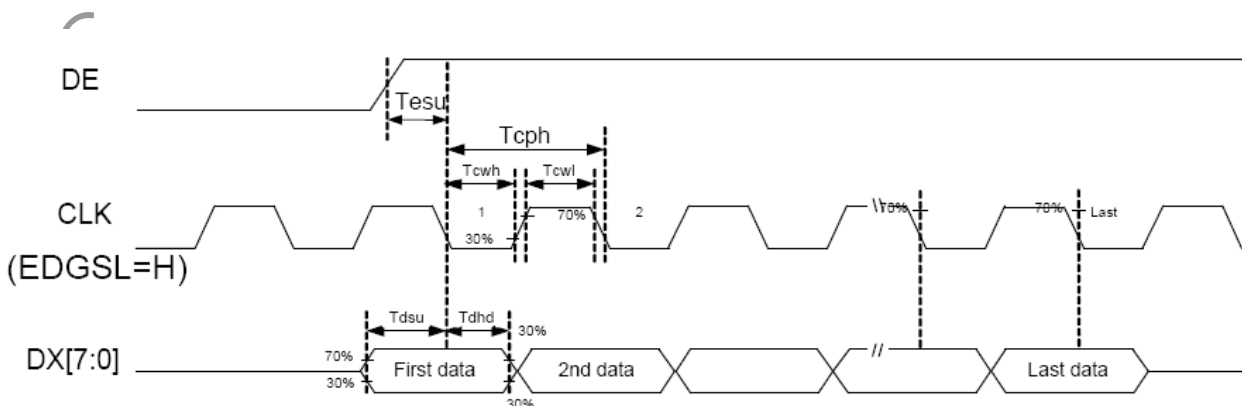
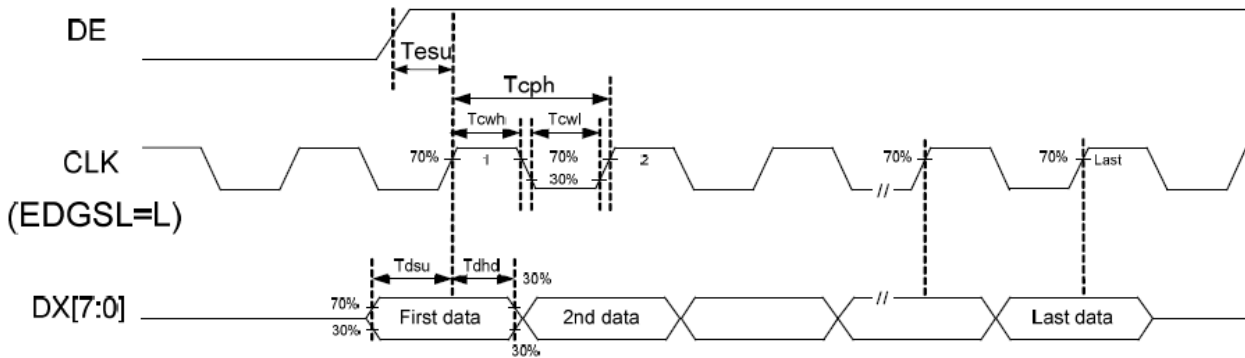

6.3 Data input format

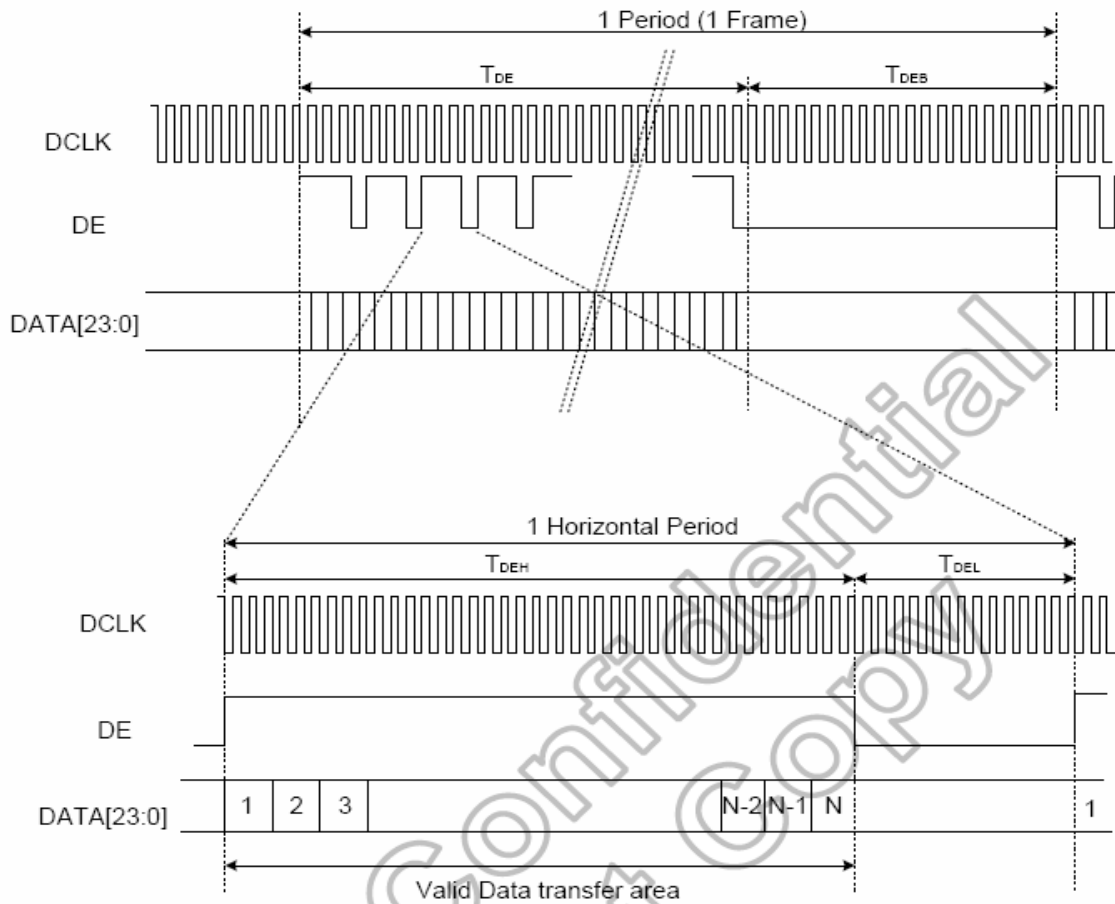

Brief Spec

6.4 Power ON/OFF sequence

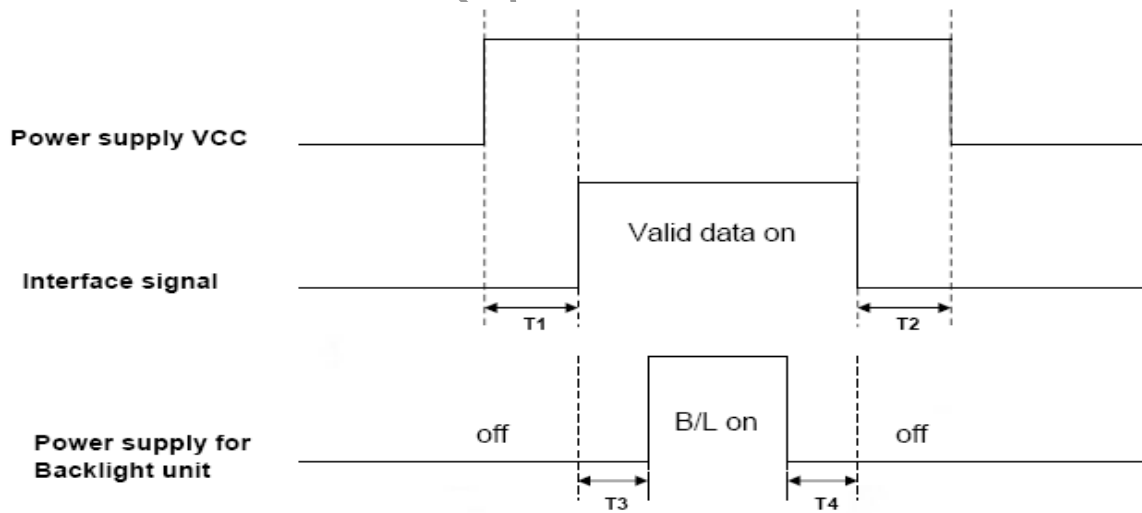

Parameter	SPEC			Unit
	Min.	Typ.	Max.	
T1	0	-	60	ms
T2	0	-	60	ms
T3	200	-	-	ms
T4	200	-	-	ms

7. OPTICAL CHARACTERISTIC

Item	Symbol	Condition	Min.	Typ.	Max.	Unit	Remark	
Response time	Tr	$\theta = 0^\circ$ 、 $\Phi = 0^\circ$	-	5	10	.ms	Note 3,5	
	Tf		-	11	16	.ms		
Contrast ratio	CR	At optimized viewing angle	250	400	-	-	Note 4,5	
Color Chromaticity	White	Wx Wy	$\theta = 0^\circ$ 、 $\Phi = 0$	Typ-0.03	0.299	Typ+0.03	-	Note 2,6,7
					0.328			
Color Saturation (NTSC)	-	-	-	45%	-	-	Center of display	
Viewing angle	$\psi = 180^\circ$	θl	$CR \geq 10$	65	70	-	Deg.	Note 1
	$\psi = 0^\circ$	θr		65	70	-		
	$\psi = 90^\circ$	θu		55	60	-		
	$\psi = 270^\circ$	θd		55	60	-		
Brightness	-	-	240	280	-	cd/m ²	Center of display	

Note 1: Definition of viewing angle range

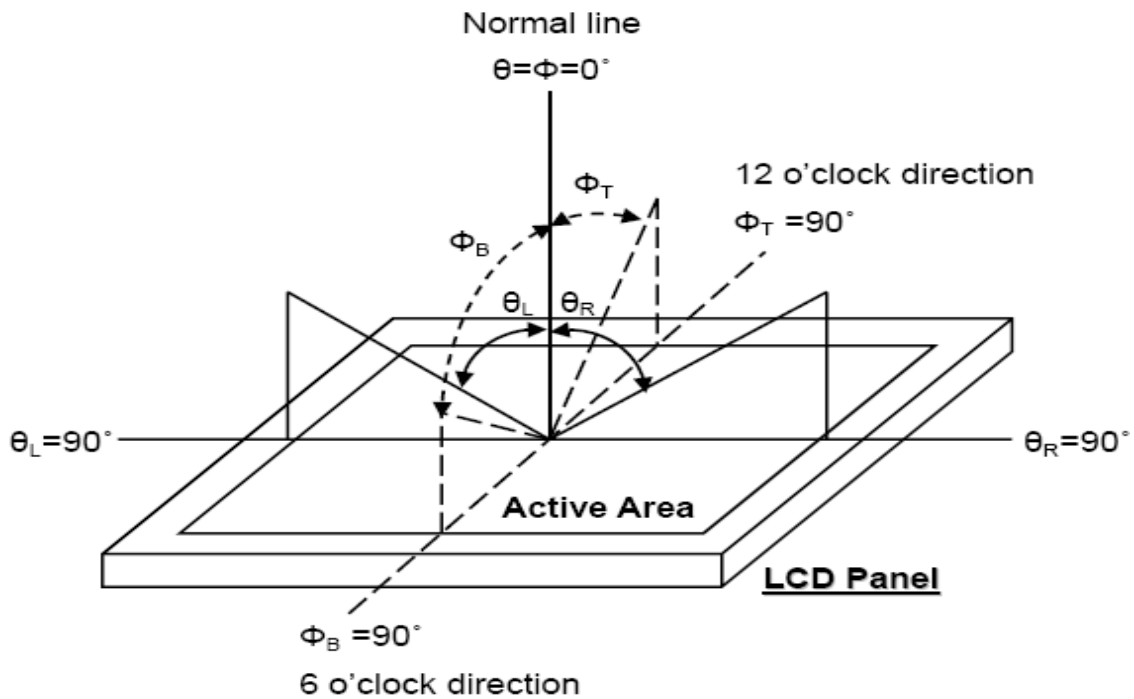

Fig. 7-1 Definition of viewing angle

Brief Spec

Note 2: Test equipment setup:

After stabilizing and leaving the panel alone at a driven temperature for 10 minutes, the measurement should be executed. Measurement should be executed in a stable, windless, and dark room. Optical specifications are measured by Topcon BM-7 luminance meter 1.0° field of view at a distance of 50cm and normal direction.

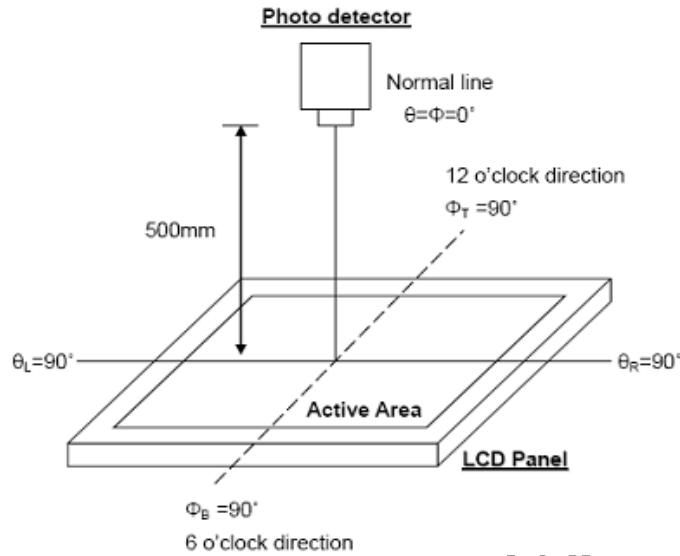

Fig.7-2 Optical measurement system setup

Note 3: Definition of Response time:

The response time is defined as the LCD optical switching time interval between “White state and “Black” state. Rise time, T_r , is the time between photo detector output intensity changed from 90% to 10% . And fall time, T_f , is the time between photo detector output Intensity changed from 10% to 90% .

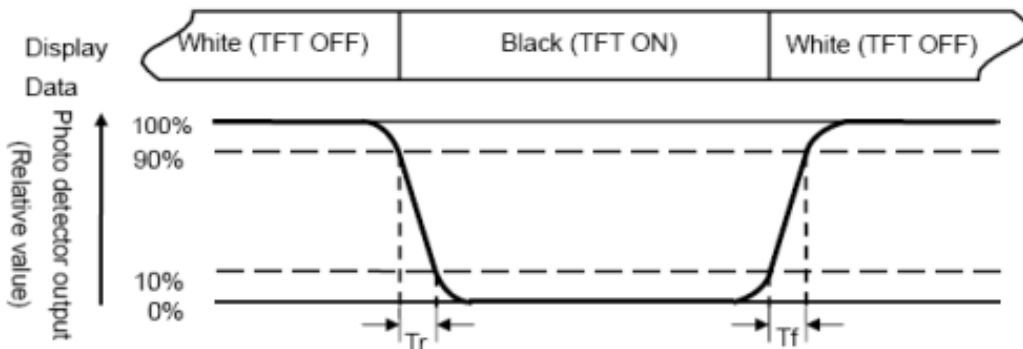

Fig. 3-3 Definition of response time

Note 4: Definition of contrast ratio:

The contrast ratio is defined as the following expression.

$$\text{Contrast ratio (CR)} = \frac{\text{Luminance measured when LCD on the "White" state}}{\text{Luminance measured when LCD on the "Black" state}}$$

ONLY

IDENTIAL-FORK

Note 5: White $V_i = V_{i50} \pm 1.5V$

Black $V_i = V_{i50} \pm 2.0V$

“±” means that the analog input signal swings in phase with VCOM signal.

“±” means that the analog input signal swings out of phase with VCOM signal.

The 100% transmission is defined as the transmission of LCD panel when all the input terminals of module are electrically opened.

Note 6: Definition of color chromaticity (CIE 1931)

Color coordinates measured at the center point of LCD

Note 7: Measured at the center area of the panel when all the input terminals of LCD panel are electrically opened.

Note 8 : Uniformity (U) = $\frac{\text{Brightness (min)}}{\text{Brightness (max)}} \times 100\%$

CONFIDENTIAL-FOR REVIEW ONLY

Brief Spec

8. TOUCH PANEL

8.1 Block diagram

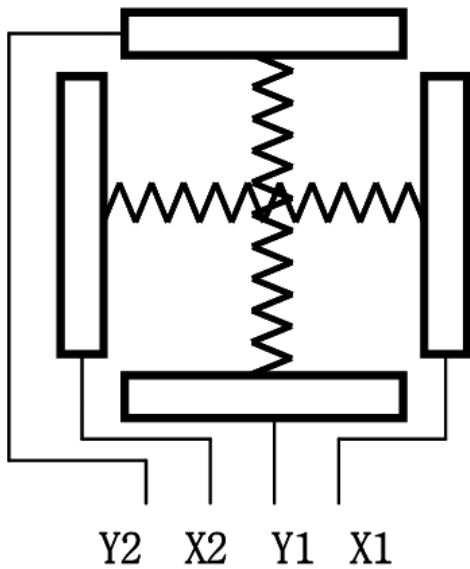

Top View

X : Upper electrode
Y : Lower electrode

Brief Spec

8.2 Touch Panel PIN Definition

Pin	Symbol	I/O	Function
1	X1	Right	Right electrode - differential analog
2	Y1	Bottom	Bottom electrode - differential analog
3	X2	Left	Left electrode - differential analog
4	Y2	Top	Top electrode - differential analog

9. INTERFACE

9.1 LCM PIN Definition

Pin No.	Symbol	Description	Remark
1	GND	Power Ground	
2	GND	Power Ground	
3	Reserve	For internal Testing	
4	Reserve	For internal Testing	
5	Reserve	For internal Testing	
6	Reserve	For internal Testing	
7	Vcc	Power Supply for Digital Circuit	
8	Vcc	Power Supply for Digital Circuit	
9	DE	Data Enable	
10	GND	Power Ground	
11	GND	Power Ground	
12	GND	Power Ground	
13	B5	Blue Data 5 (MSB)	
14	B4	Blue Data 4	
15	B3	Blue Data 3	
16	GND	Power Ground	
17	B2	Blue Data 2	
18	B1	Blue Data 1	
19	B0	Blue Data 0 (LSB)	
20	GND	Power Ground	
21	G5	Green Data 5 (MSB)	
22	G4	Green Data 4	

23	G3	Green Data 3	
24	GND	Power Ground	
25	G2	Green Data 2	
26	G1	Green Data 1	
27	G0	Green Data 0 (LSB)	
28	GND	Power Ground	
29	R5	Red Data 5 (MSB)	
30	R4	Red Data 4	
31	R3	Red Data 3	
32	GND	Power Ground	
33	R2	Red Data 2	
34	R1	Red Data 1	
35	R0	Red Data 0 (LSB)	
36	GND	Power Ground	
37	GND	Power Ground	
38	DCLK	Clock Signals ; Latch Data at the Falling Edge	
39	GND	Power Ground	
40	GND	Power Ground	

Brief Spec

9.2 Backlight Driving Part

Pin No.	Symbol	Description
1	VLED+	Red, LED_ Anode
2	VLED-	White, LED_ Cathode

Note: The backlight interface connector is a model **SM02B-BHSS-1-TB** manufactured by JST or equivalent. The matching connector part number is **BHSR-20VS-1** manufactured by JST or equivalent.

10. BLOCK DIAGRAM

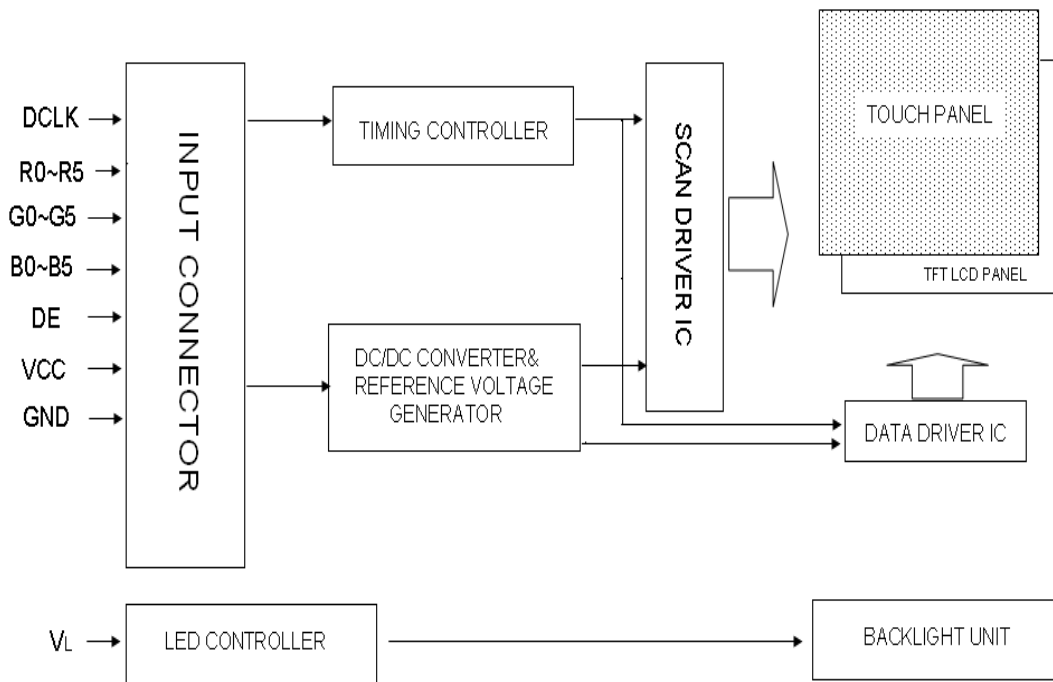

11. QUALITY ASSURANCE

No.	Test Items	Test Condition	REMARK
1	High Temperature Storage Test	Ta=80°C Dry 240h	
2	Low Temperature Storage Test	Ta=-30°C Dry 240h	
3	High Temperature Operation Test	Ta=70°C Dry 240h	
4	Low Temperature Operation Test	Ta=-20°C Dry 240h	
5	High Temperature and High Humidity Operation Test	Ta=60°C 90%RH 240h	
6	Electro Static Discharge Test	150pF, 330Ω, ±8KV(Contact)/±15KV(Air), 5 points/panel, 5 times/point	
7	Shock Test (non-operating)	Half sine wave, 180G, 2ms one shock of each six faces (I.e. run 180G 2ms for all six faces)	
8	Vibration Test (non-operating)	Sine wave, 10 ~ 500 ~ 10Hz, 1.5G, 0.37oct/min 3 axis, 1hour/axis	
9	Thermal Shock Test	-20°C (0.5h) ~ 70°C (0.5h) / 100 cycles(Dry)	

***** Ta= Ambient Temperature

Brief Spec

CONFIDENTIAL-FOR REVIEW ONLY

13. PACKAGE INFORMATION

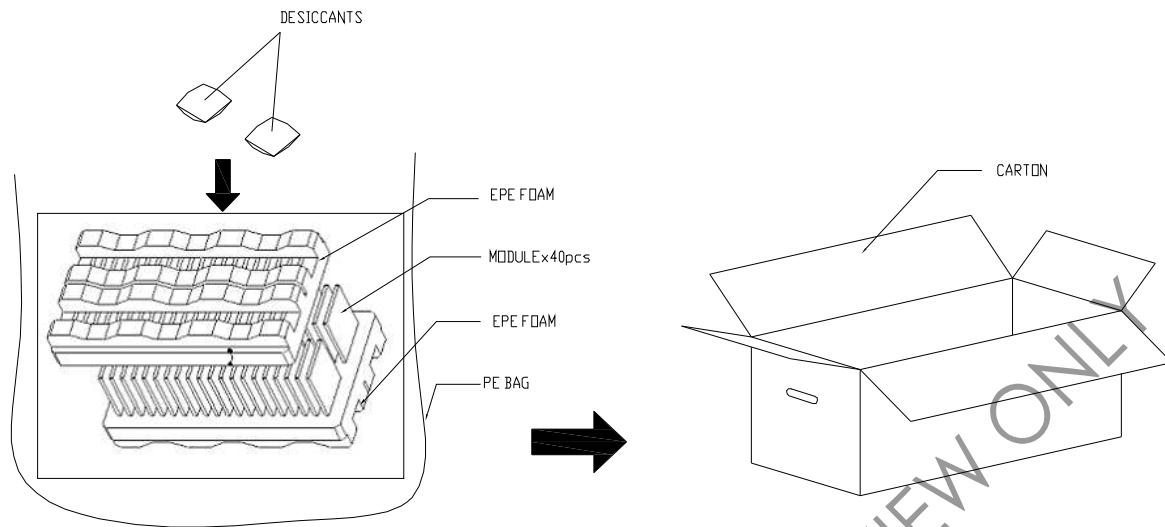

Brief Spec

14. PRECAUTIONS

Please pay attention to the following when you use this TFT LCD module.

14.1 MOUNTING PRECAUTIONS

- (1) You must mount a module using arranged in four corners or four sides.
- (2) You should consider the mounting structure so that uneven force (ex. Twisted stress) is not applied to the module.
And the case on which a module is mounted should have sufficient strength so that external force is not transmitted directly to the module.
- (3) Please attach a transparent protective plate to the surface in order to protect the polarizer.
Transparent protective plate should have sufficient strength in order to the resist external force.
- (4) You should adopt radiation structure to satisfy the temperature specification.
- (5) Acetic acid type and chlorine type materials for the cover case are not describe because the former generates corrosive gas of attacking the polarizer at high temperature and the latter causes circuit break by electro-chemical reaction.
- (6) Do not touch, push or rub the exposed polarizers with glass, tweezers or anything harder than HB pencil lead. And please do not rub with dust clothes with chemical treatment.
Do not touch the surface of polarizer for bare hand or greasy cloth. (Some cosmetics are determined to the polarizer)
- (7) When the surface becomes dusty, please wipe gently with adsorbent cotton or other soft materials like chamois soaks with petroleum benzene. Normal-hexane is recommended for cleaning the adhesives used to attach front / rear polarizers. Do not use acetone, toluene and alcohol because they cause chemical damage to the polarizer.
- (8) Wipe off saliva or water drops as soon as possible. Their long time contact with polarizer causes deformations and color fading.
- (9) Do not open the case because inside circuits do not have sufficient strength.

14.2 OPERATING PRECAUTIONS

- (1) The spike noise causes the mis-operation of circuits. It should be lower than following voltage : $V = \pm 200\text{mV}$ (Over and under shoot voltage)
- (2) Response time depends on the temperature. (In lower temperature, it becomes longer.)

- (3) Brightness depends on the temperature. (In lower temperature, it becomes lower)
And in lower temperature, response time (required time that brightness is stable after turned on) becomes longer.
- (4) Be careful for condensation at sudden temperature change. Condensation makes damage to polarizer or electrical contacted parts. And after fading condensation, smear or spot will occur.
- (5) When fixed patterns are displayed for a long time, remnant image is likely to occur.
- (6) Module has high frequency circuits. Sufficient suppression to the electromagnetic interference shall be done by system manufacturers. Grounding and shielding methods may be important to minimize the interference.

14.3 ELECTROSTATIC DISCHARGE CONTROL

Since a module is composed of electronic circuits, it is not strong to electrostatic discharge. Make certain that treatment persons are connected to ground through wristband etc. And don't touch interface pin directly.

14.4 PRECAUTIONS FOR STRONG LIGHT EXPOSURE

Strong light exposure causes degradation of polarizer and color filter.

14.5 STORAGE

When storing modules as spares for a long time, the following precautions are necessary.

- (1) Store them in a dark place. Do not expose the module to sunlight or fluorescent light. Keep the temperature between 5°C and 35°C at normal humidity.
- (2) The polarizer surface should not come in contact with any other object. It is recommended that they be stored in the container in which they were shipped.

14.6 HANDLING PRECAUTIONS FOR PROTECTION FILM

- (1) When the protection film is peeled off, static electricity is generated between the film and polarizer. This should be peeled off slowly and carefully by people who are electrically grounded and with well ion-blown equipment or in such a condition, etc.
- (2) The protection film is attached to the polarizer with a small amount of glue. Is apt to remain on the polarizer. Please carefully peel off the protection film without rubbing it against the polarizer.
- (3) When the module with protection film attached is stored for a long time, sometimes there remains a very small amount of glue still on the polarizer after the protection film is peeled off.
- (4) You can remove the glue easily. When the glue remains on the polarizer surface or its vestige is recognized, please wipe them off with absorbent cotton waste or other soft material like chamois soaked with normal-hexane.