

- CONTENTS -

1. Features
2. Outline dimensions
3. Package material
4. Absolute Maximum Ratings
5. Electrical Optical Characteristics
6. Ranks
7. Taping
8. Packing Structure
9. Characteristic Diagrams
10. Precautions to taken
11. Reliability
12. Precautions in use
13. Revision history sheet

1. Features

- Package : SMD package1000
- 1.6×0.8×0.4 mm(L×W×H) small size surface mount type
- Color Coordinates : X = 0.30, Y = 0.30 acc. to CIE 1931, at If=3mA
- Viewing angle : extremely wide(160°)
- Technology : InGaN
- Soldering methods : IR reflow soldering
- Taping : 8 mm conductive black carrier tape & antistatic clear cover tape.
5000pcs/reel, Φ180 mm wheel

2. Outline dimensions

(unit : mm)

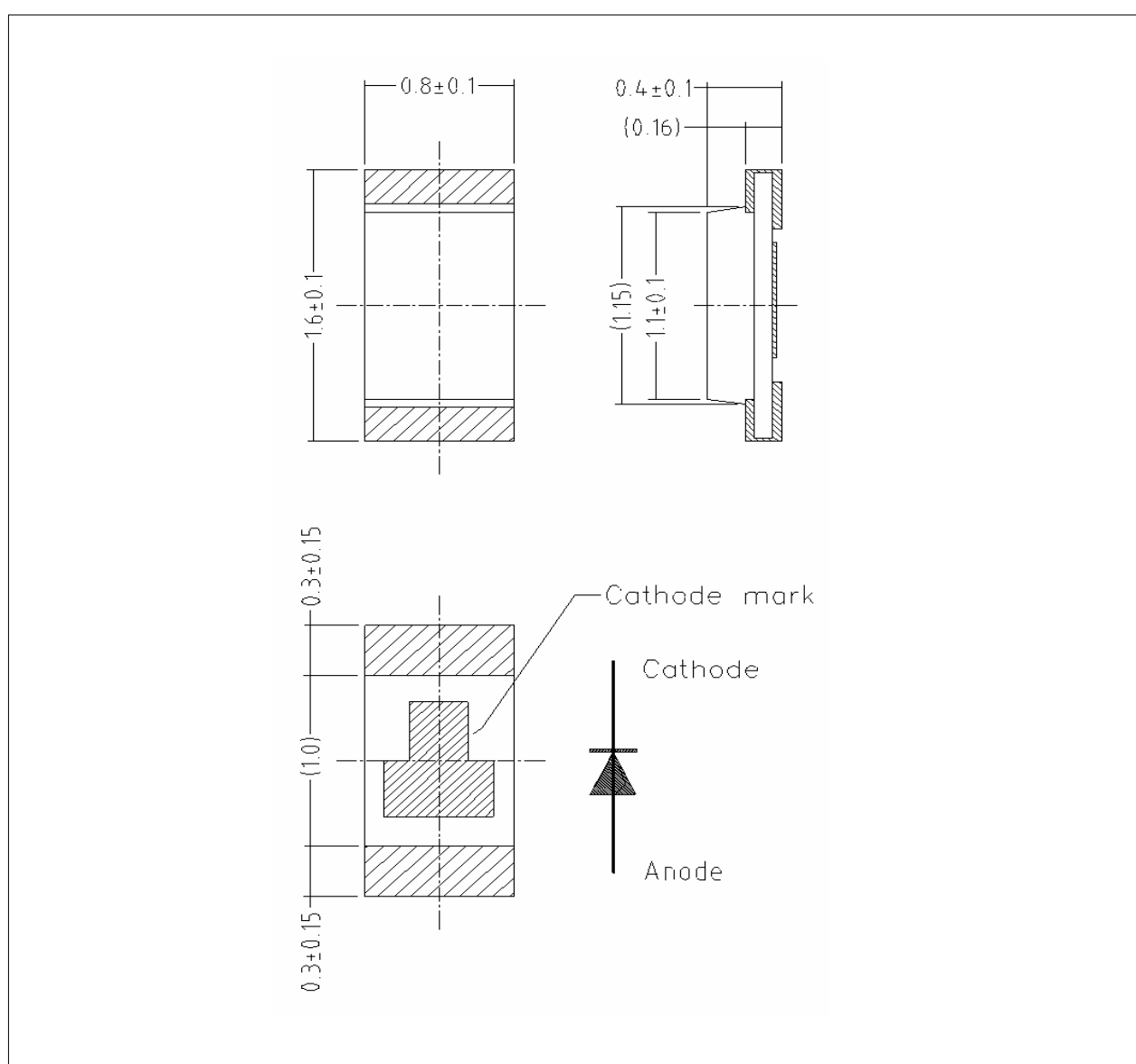

3. Package material

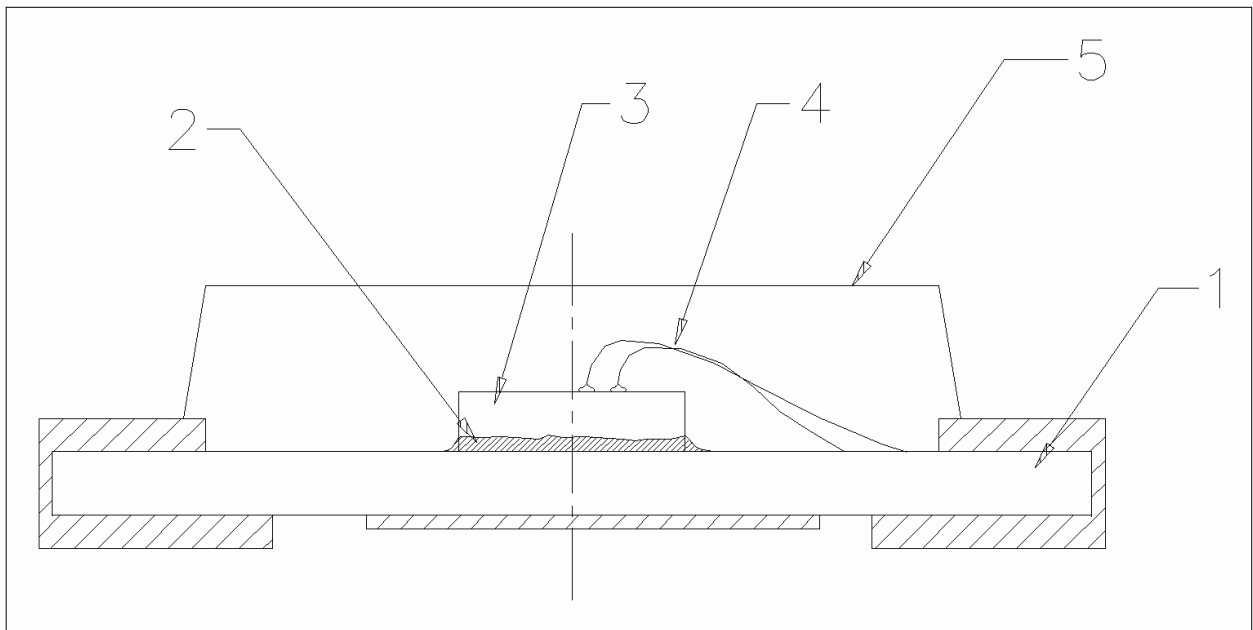

(1) Material construction

Number	Item	Material
1	PCB	C3965
2	Die adhesive	Epoxy
3	LED chip	GaN/Sapphire
4	Au wire	1.0mil
5	Mold epoxy	Clear Epoxy + Phosphor

4. Absolute Maximum Ratings

Parameter	Symbol	Value	Unit
Power dissipation	P_D	70	mW
Forward Current	I_F	20	mA
* ¹ Peak Forward Current	I_{FP}	100	mA
Reverse Voltage	V_R	5	V
Operating Temperature	T_{opr}	-30~+85	°C
Storage Temperature	T_{stg}	-40~+100	°C
* ² Soldering Temperature	T_{sol}	240°C for 5 seconds	

*1. Duty ratio 1/10, Pulse Width 10msec.

*2. Mounted on PC board FR4(pad size $\geq 16 \text{ mm}^2$)

5. Electrical Optical Characteristics

($T_a = 25^\circ\text{C}$)

Characteristic	Symbol	Test Condition	Min.	Typ.	Max.	Unit
ESD Check Forward Voltage	V_{F2}	$I_F = 10\mu\text{A}$	2.0	-	3.0	V
Reverse Current	I_R	$V_R = 5\text{V}$	-	-	10	μA
* ⁶ Half Angle	$\theta_{1/2}$	$I_F = 20\text{mA}$	-	± 80	-	deg

*6. $\theta_{1/2}$ is the off-axis angle where the luminous intensity is 1/2 the peak intensity

6. Ranks

(1) Chromaticity Coordinates ranks

($T_a=25^\circ\text{C}$)

	Rank A				Rank B				Rank C			
x	0.28	0.28	0.30	0.30	0.30	0.30	0.32	0.32	0.32	0.32	0.34	0.34
y	0.26	0.30	0.29	0.33	0.29	0.33	0.32	0.36	0.32	0.36	0.35	0.39

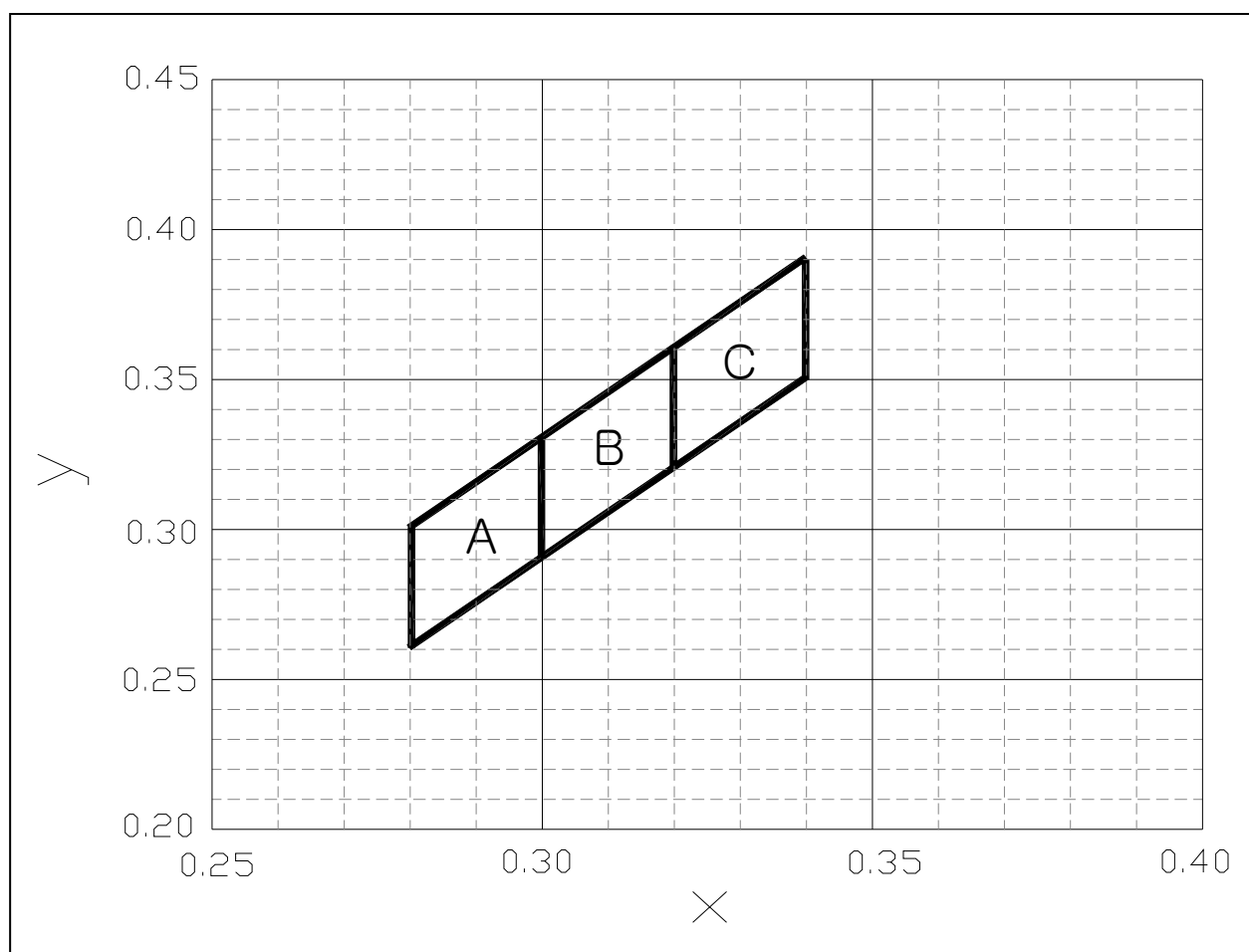

(2) Luminous intensity ranks

(Ta=25°C)

Iv RANK	Test Condition	Min.	Typ.	Max.	Unit
C	I _F = 3mA	18	-	28	mcd
D		28	-	40	
E		40	-	56	

* Luminous intensity is tested at a current pulse duration of 25 ms and an accuracy of ±11%.

* Intensity Measured : 0.01sr(CIE. LED_B)

(3) Forward Voltage

(Ta=25°C)

V _F RANK	Test Condition	Min.	Typ.	Max.	Unit
0	I _F = 3mA	2.60	-	2.70	V
1		2.70	-	2.80	
2		2.80	-	2.90	
3		2.90	-	3.00	
4		3.00	-	3.10	

* Voltages are tested at a current pulse duration of 1 ms and an accuracy of ±0.1V.

(4) Precautions On LED using

* To avoid optical difference, Please do not mix differently-ranked product.

7. Taping

(1) Dimension of wheel((Material : PS Conductive, 10E9~12Ω)

(Unit : mm)

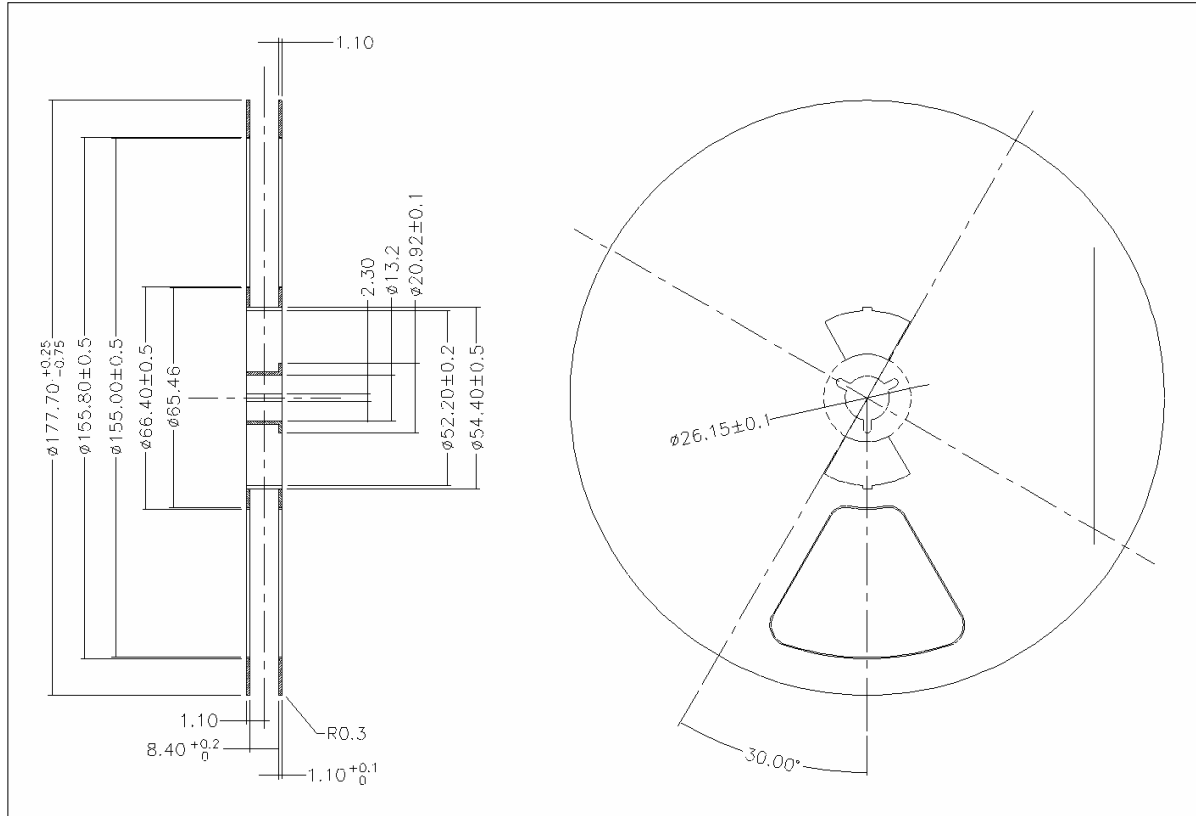

(2) Dimension of tape(Material : PS Conductive, 10E4~5Ω)

(Unit : mm)

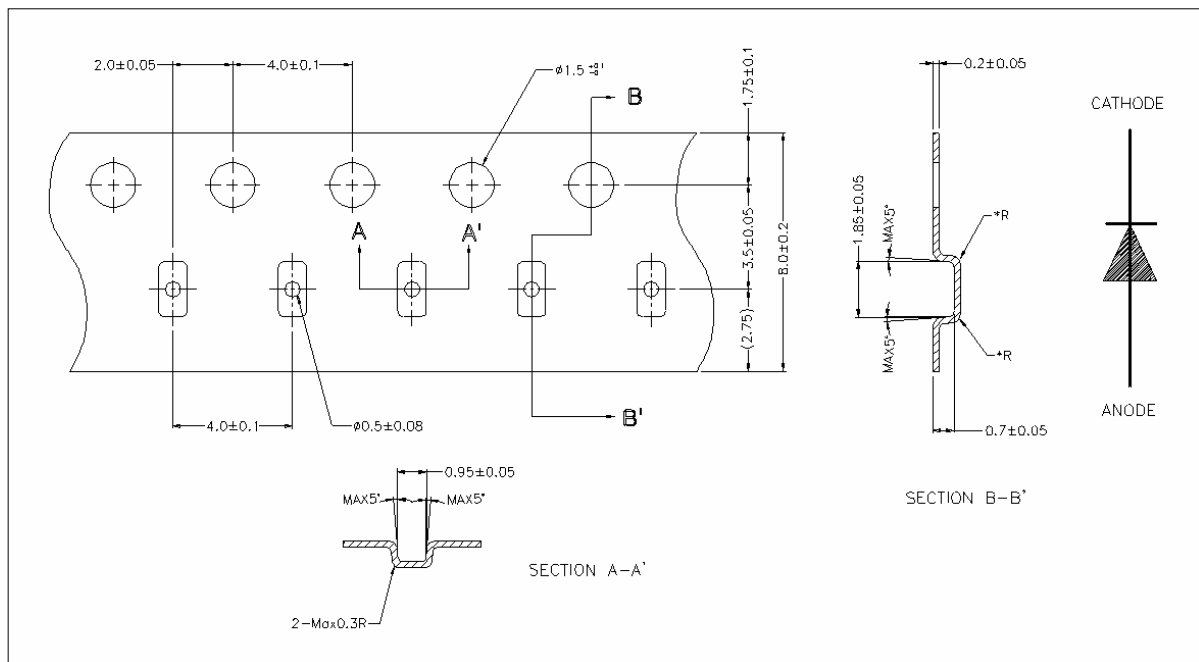

(3) Details of CHIP LEDs loading on tape

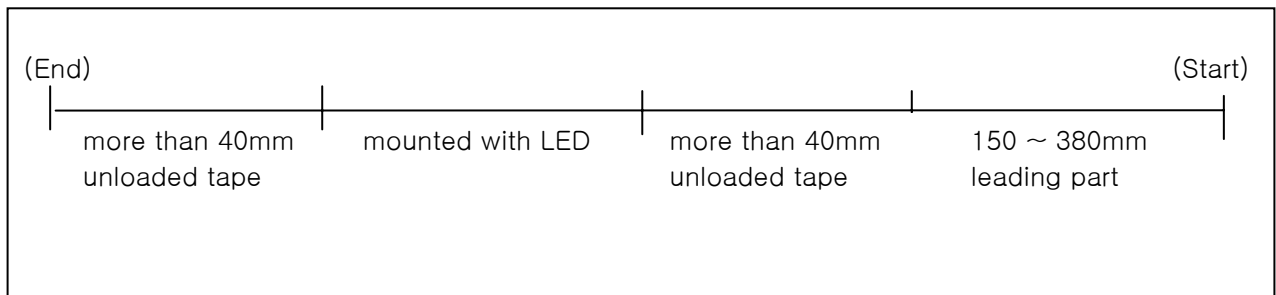

(4) Loading quantity per reel : 5,000pcs

8. Packing Structure

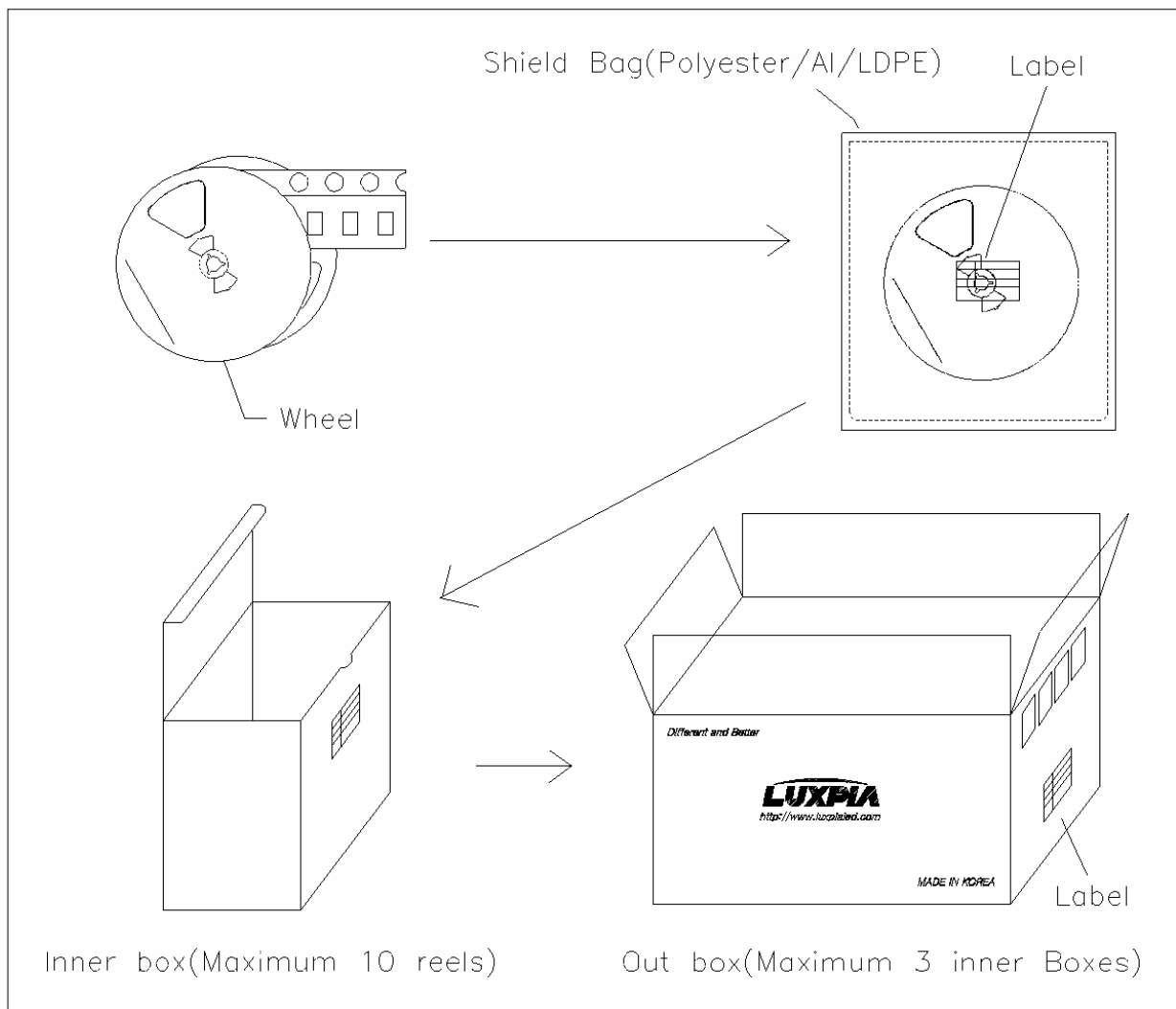

9. Characteristic Diagrams

(1) I_F - V_F Relative Luminous Intensity
vs Forward Current

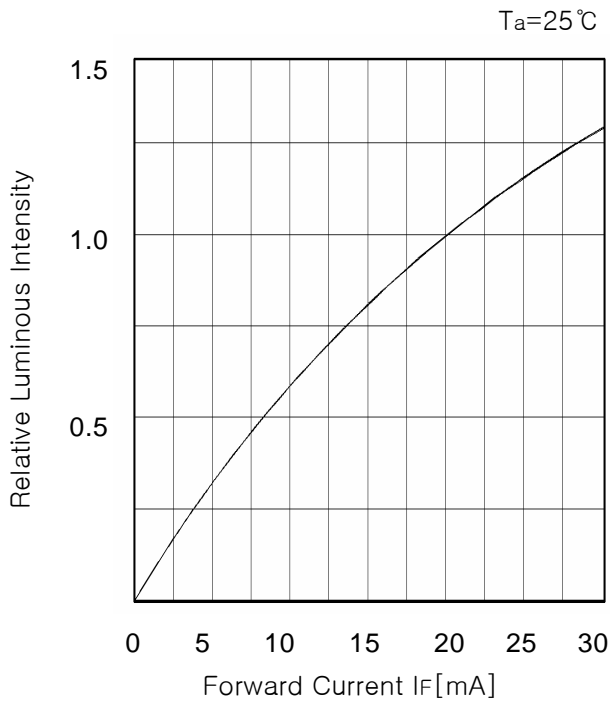

(2) I_V - I_F

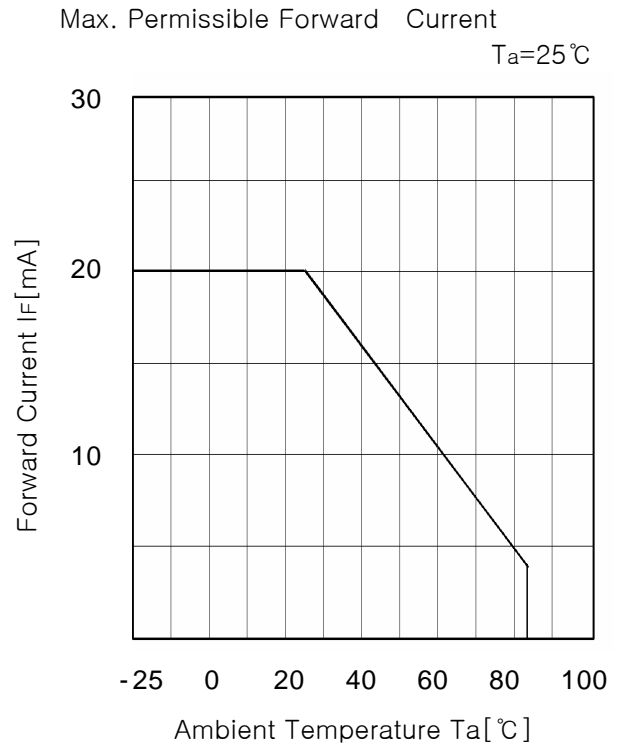

(3) Forward Current vs Forward Voltage

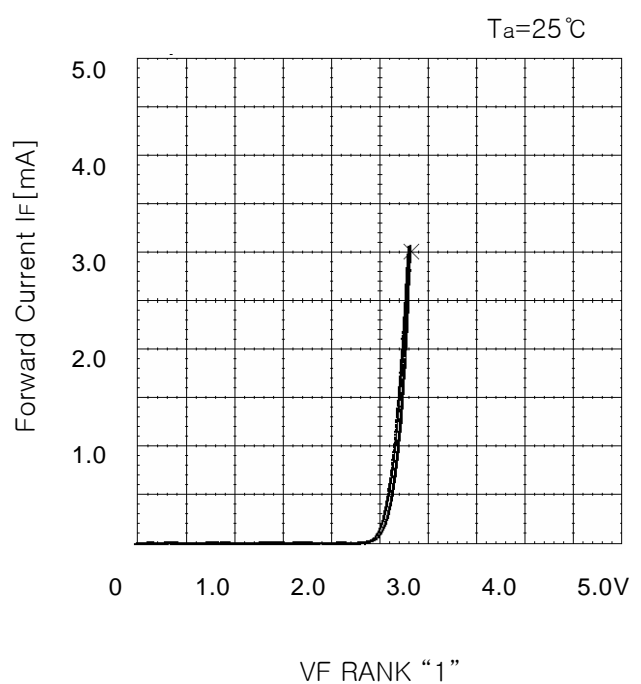
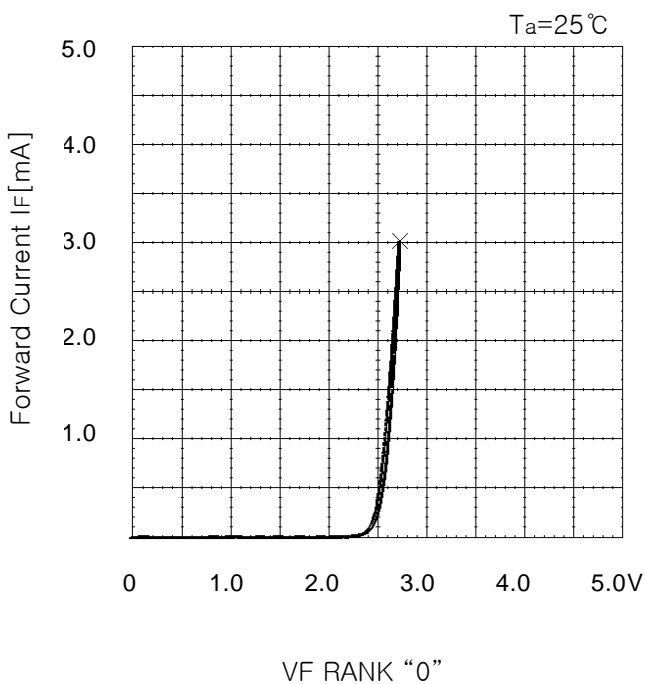

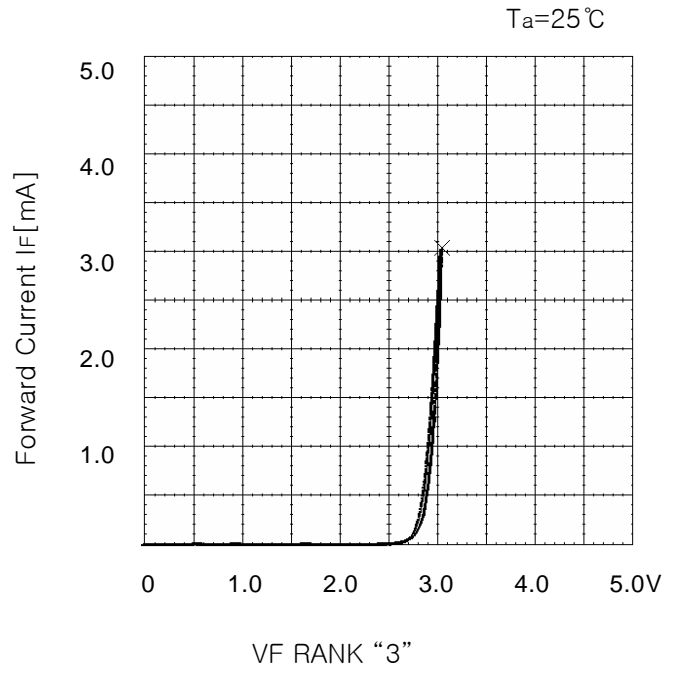
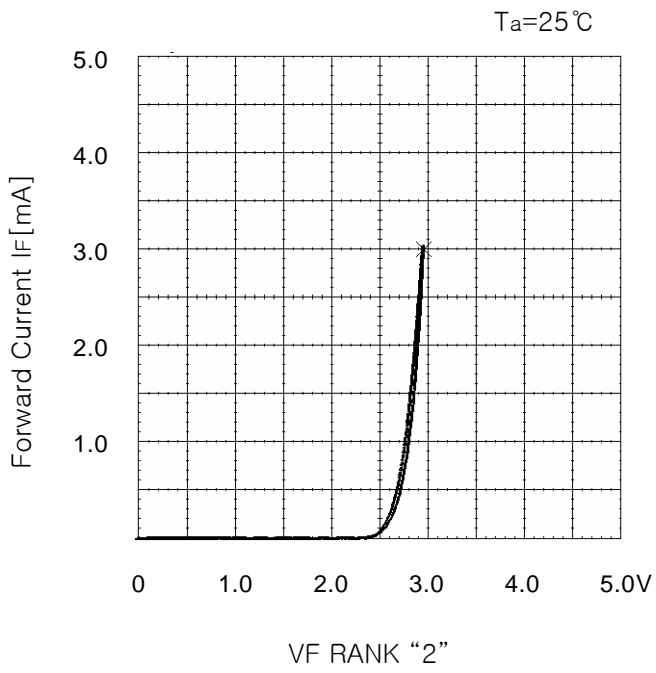

(4) Relative Spectral Emission

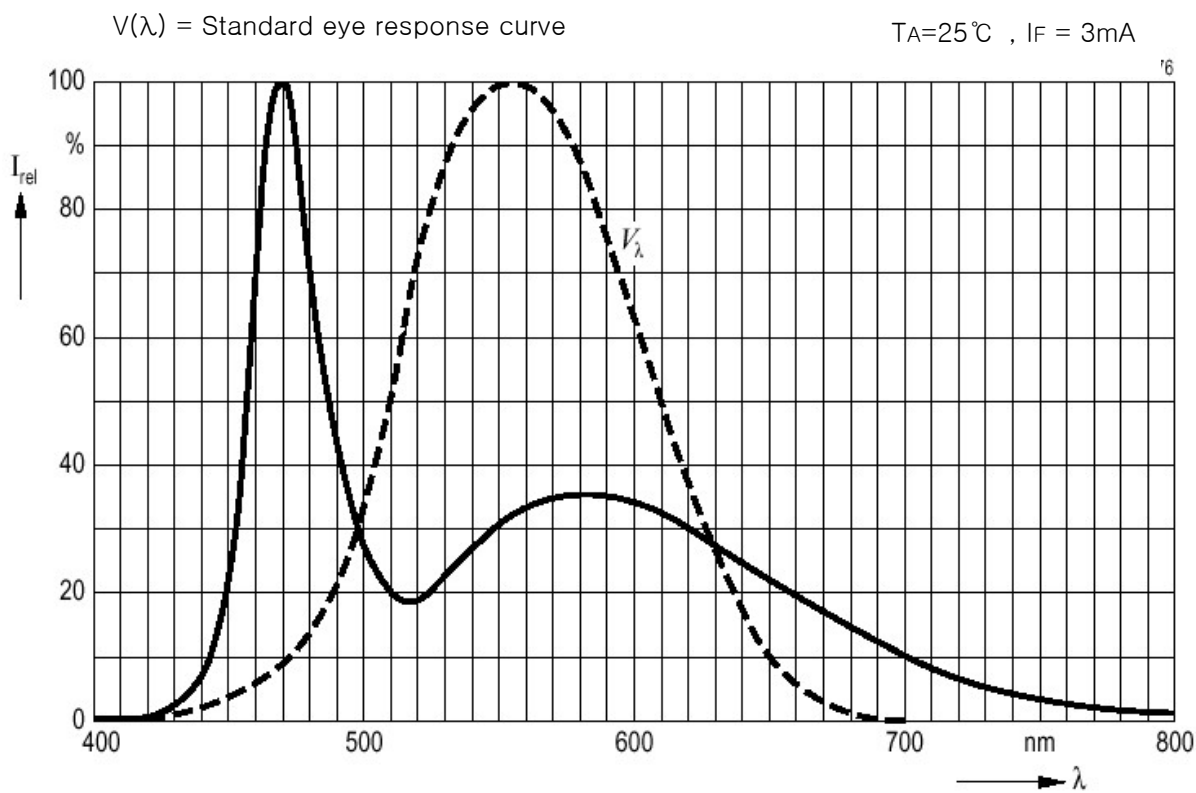

(5) Radiation Characteristic

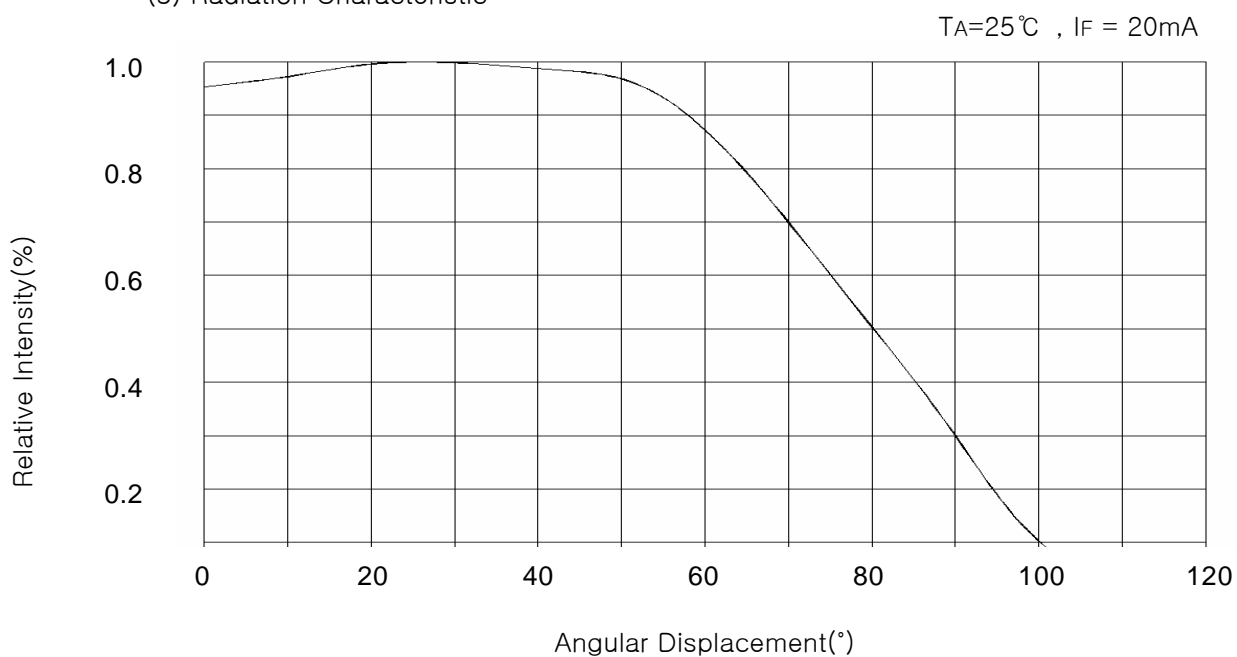

10. Precautions to taken

(1) Reflow soldering

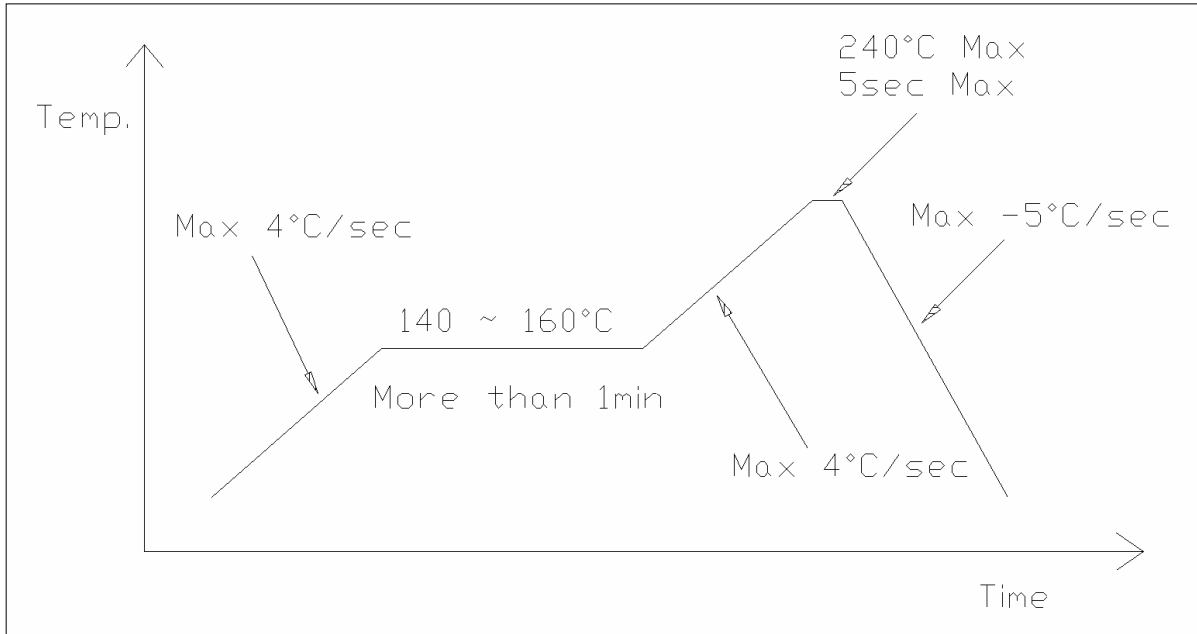

(2) For manual solder

Not more than 5sec @max 300°C , under soldering iron

(3) Recommendable soldering pattern(For reflow soldering)

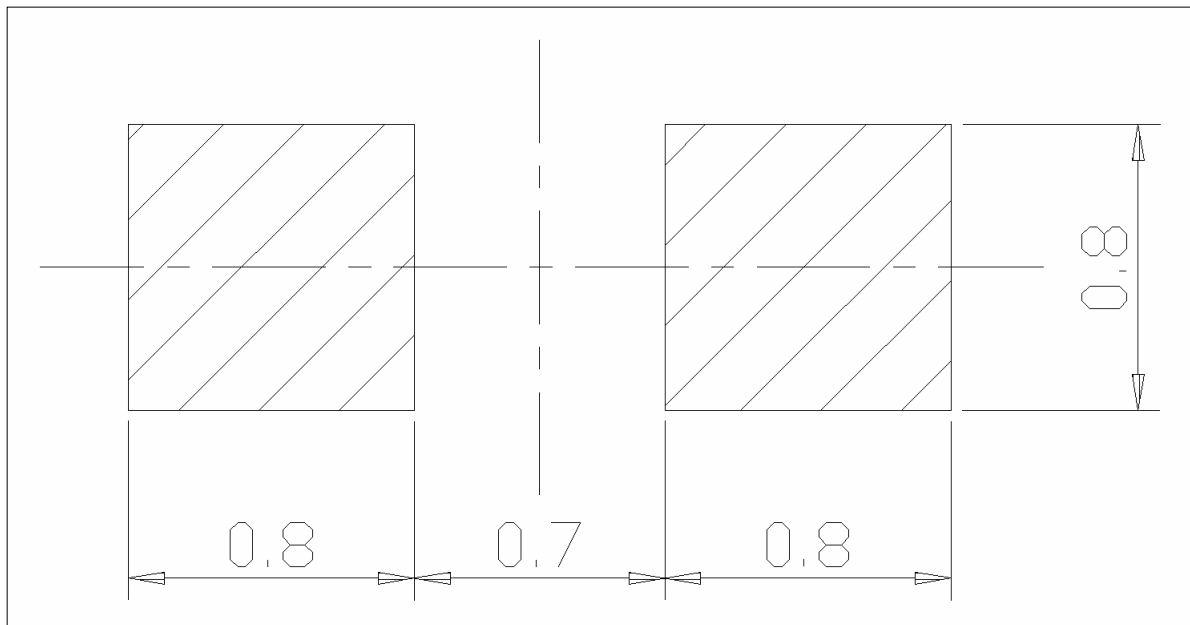

11. Reliability

(1) The Reliability criteria of SMD LED

ITEM	Symbol	Test Condition	Limit	
			Min.	Max.
Forward Voltage	V _F	I _F = 20mA	I.V × 0.8	I.V × 1.2
Reverse Current	I _R	V _R = 5V	-	50μA
Luminous intensity	I _v	I _F = 20mA	I.V × 0.5	I.V × 1.5

* I : Initial Value U : Upper Spec Limit L : Lower Spec Limit

(2) Results of reliability Test

NO	Item	Test Conditions	Test Hours /Cycle	Sample Size	Ac/Re
1	Steady state Operating Life Test(OLT)	T _A = 25℃ I _F =20mA	1000HR's	45 pcs	0/1
2	Steady state Operating Life of Low Temperature (LTOL)	T _A = -30℃ I _F =20mA	1000HR's	45 pcs	0/1
3	Steady state Operating Life of High Temperature (HTOL)	T _A = 85℃ I _F =5mA	1000HR's	45 pcs	0/1
4	Steady state Operating Life of High Humidity Heat (H3TOL)	T _A = 60℃, RH=90% I _F =10mA	1000HR's	45 pcs	0/1
5	Temperature Cycle (T/C)	T _A =-40℃/room/100℃ (30min/5min/30min)	100 cycle	45 pcs	0/1

12. Precautions in use

(1) Soldering Conditions

- 1) When soldering, leave minimum clearance between the resin and the soldering point.
- 2) Maximum allowable soldering conditions
Soldering dipping : 260 degrees C max., 5 seconds max., 1 time.
Soldering iron : 350 degrees C max., 5 seconds max., 1 time, power 40w max.
- 3) Contact between molten solder and the resin must be avoided.
- 4) Correction the soldered position after soldering must be avoided.
- 5) In soldering, do not apply any stress to the lead frame, particularly when heated.
- 6) When other SMD parts on the same circuit board and adhesive is to be cured, maximum allowable conditions are : 120 degrees C max., 60 seconds max.

(2) Lead forming and cut

- 1) Lead forming must be done below the tie bar cutting portion.
- 2) When forming a lead, do not stress the resin case.
- 3) Lead forming must be done before soldering.
- 4) Cutting the lead frame at high temperature may result in personal injury.
Cut the lead frame at room temperature.

(3) Assembly

- 1) Do not apply any stress to the lead frame while assembling.
- 2) When mounting products onto PCBs, the pitch between the mounting holes must match the pitch of the LEDs.

(4) Static Electricity

- 1) These products are sensitive, a high standard of care must be used. Particularly if an over-current and over-voltage which exceeds the Absolute Maximum Rating of Products is applied, the overflow in energy may cause damage to, or possibly result in destruction of, the Products. Customer shall take absolutely secure countermeasures against static electricity and surge when handling Products.
- 2) A protection device should be installed in the LED driving circuit, which dose not exceed the max. rating for surge current during on/off switching.
- 3) Proper grounding of Products, use of conductive mat, semiconductive working uniform and shoes, and semiconductive containers are considered to be effective as countermeasures against static electricity and surge.
- 4) A soldering iron with a grounded tip is recommended. An ionizer should also be installed where risk of static generation is high.

(5) Safety Precautions

- 1) Users must comply with the laws and public regulations concerning safety.
The light output of the products may cause injuries to human eyes in circumstances where the products are viewed directly with unshielded eyes for more than a few seconds.

13. Revision history sheet

Spec NO.			
Title	Specification for Approval		
Times	Date	Summary of revision	Remarks
1	2002. 02. 08	신규 제정	
2	2003. 02. 26	자재 변경	
3	2003. 11. 17	특성 변경	
4	2004. 04. 22	VF, Iv 변경	