

DATE : FEB.20.2016

MODEL NO .: LX121XS-LE01

**NOTE : Extension code [-0]
→ LX121XS-LE01 V.0
Surface type [**ARC150T**]
Green Product (Complied with RoHS requirement)**

APPROVED BY : _____

PREPARED BY : _____

CONTENTS

Revision History	----- (3)
General Description	----- (4)
1. Absolute Maximum Ratings	----- (5)
1.1 Absolute Ratings Of Environment	
1.2 Electrical Absolute Ratings	
2. Optical Characteristics	----- (7)
3. Electrical Characteristics	----- (10)
3.1 TFT LCD Module	
4. Block Diagram	----- (13)
4.1 TFT LCD Module	
5. Input Terminal Pin Assignment	----- (14)
5.1 Input Signal & Power	
5.2 LVDS Interface	
5.3 LED Back-light Unit	
5.4 Timing Diagrams of LVDS For Transmitting	
5.5 Input Signals, Basic Display Colors and Gray Scale of Each Color.	
5.6 Pixel format	
6. Interface Timing	----- (19)
6.1 Timing Parameters	
6.2 Timing Diagrams of interface Signal	
6.3 Power ON/OFF Sequence	
7. Outline Dimension	----- (21)
8. PACKING	----- (22)
9. Marking & Others	----- (23)
10. General Precautions	----- (25)
11. MECHANICAL CHARACTERISTICS	----- (26)

GENERAL DESCRIPTION

DESCRIPTION

LX121XS-LE01 is a color active matrix TFT (Thin Film Transistor) liquid crystal display (LCD) that uses amorphous silicon TFT as a switching devices. This model is composed of a TFTLCD panel, a driver circuit and a back-light system. The resolution of a 12.1" contains 1024 x 768 pixels and can display up to 262,144 colors. 6 o'clock direction is the optimum viewing angle.

FEATURES

- Ultra Thin and light weight
- High contrast ratio
- XGA (1024x768 pixels) resolution
- Low power consumption
- DE (Data enable) only mode.
- 3.3V LVDS Interface
- On board EDID chip
- Auto Recovery Function
- RoHS Compliance
- LED Backlight Unit

APPLICATIONS

- Notebook PC and desktop monitors
- If the usage of this product is not for PC application, but for others, please contact WEI.

GENERAL INFORMATION

ITEM	SPECIFICATION	UNIT	NOTE
Display area	245.76(H) x 184.32(V) (12.1" diagonal)	mm	
Driver element	a-Si TFT active matrix		
Display colors	262,144	Color	
Number of pixel	1024 x 768 (XGA)	pixel	
Pixel arrangement	RGB vertical stripe		
Pixel pitch	0.240(H) x 0.240(V) (TYP.)	mm	
Display Mode	Normally white		
Surface treatment Of Polarizer	HAZE Typ 40, HARDNESS 2H, (ARC150T)		

MECHANICAL INFORMATION

Item		Min.	Typ.	Max.	Unit	Note
Module size	Horizontal (H)	260.5	261.0	261.5	mm	
	Vertical (V)	204.3	204.6	204.8	mm	
	Depth (D)	8.2	-	12.1	mm	
Weight		-	510	-	g	

Note (1) Measurement condition of outline dimension
 . Equipment : Vernier Calipers
 . Push Force : 500g · f (minimum)

1. ABSOLUTE MAXIMUM RATINGS

1.1 ABSOLUTE RATINGS OF ENVIRONMENT

Item	Symbol	Min.	Max.	Unit	Note
Storage temperate	T_{STG}	-20	60	°C	(1)
Operating temperate (Temperature of glass surface)	T_{OPR}	0	50	°C	(1)
Shock (non-operating)	Snop	-	210	G	(2),(5)
			50		(3),(5)
Vibration (non-operating)	Vnop	-	2.41	G	(4),(5)

Note (1) Temperature and relative humidity range are shown in the figure below.
 95 % RH Max. ($40\text{ }^{\circ}\text{C} \geq T_a$)
 Maximum wet - bulb temperature at $39\text{ }^{\circ}\text{C}$ or less. ($T_a > 40\text{ }^{\circ}\text{C}$) No condensation.
 (2) 3ms, half sine wave, one time for $\pm X, \pm Y, \pm Z$.
 (3) 18ms, Trapezoidal wave, one time for $\pm X, \pm Y, \pm Z$.
 (4) 5~500 Hz, Random vibration, 30 min for X,Y,Z.
 (5) At testing Vibration and Shock, the fixture in holding the Module to be tested have to be hard and rigid enough so that the Module would not be twisted or bent by the fixture.

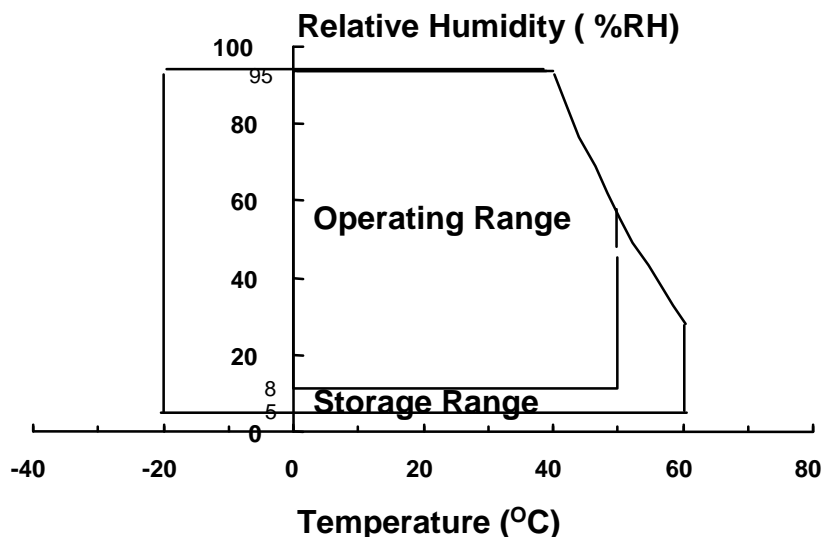

1.2 ELECTRICAL ABSOLUTE RATINGS

(1) TFT LCD MODULE

(Vss = GND = 0 V)

ITEM	Symbol	Min	Max	Unit	Note
Power Supply Voltage	Vdd	Vss-0.3	Vdd+0.3	V	(1)
Logic Input Voltage	Vin	Vss-0.3	Vdd+0.3	V	(1)

NOTE (1) Within Ta = 25 ± 2 °C

2. OPTICAL CHARACTERISTICS

The following items are measured under stable conditions. The optical characteristics should be measured in a dark room or equivalent state with the methods shown in Note (5).

Measuring equipment : TOPCON SR-3 , PR650

* Ta = 25 ± 2°C , VDD=3.3V

Item	Symbol	Condition	Min.	Typ.	Max	Unit	Note	
Contrast Ratio (5 Points)	CR	Normal Viewing Angle $\phi = 0$ $\theta = 0$		300	-	-	(1), (2), (5)	
Response Time at 25°C	Rising		T _R +T _f	-	40	70	msec	(1), (3)
	Falling							
Average Luminance of White (5point)	Y _{L,AVE}			400	450	cd/m ²	LED	
Color Chromaticity (CIE)	Red		R _X	0.539	0.569	0.599	-	(1), (5) SR-3
			R _Y	0.302	0.332	0.362		
	Green		G _X	0.282	0.312	0.342		
			G _Y	0.514	0.544	0.574		
	Blue		B _X	0.119	0.149	0.179		
			B _Y	0.102	0.132	0.162		
	White	W _X	0.285	0.313	0.341			
		W _Y	0.309	0.329	0.349			
Viewing Angle	Hor.	θ_L	-	45	-	Degree s	(1), (5) SR-3	
		θ_H	-	45	-			
	Ver.	ϕ_H	-	20	-			
		ϕ_L	-	40	-			
13 Points White Variation	δ_L		65%	-	-	-	(6)	
5 Points White Variation	δ_L		80%	-	-	-	(6)	

Note 1) Definition of Viewing Angle : Viewing angle range($10 \leq C/R$)

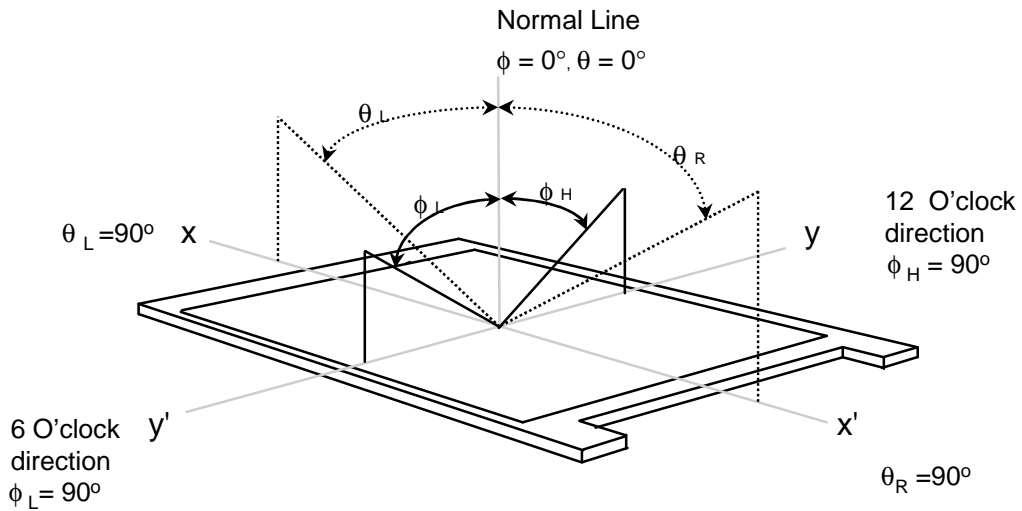

Note 2) Definition of Contrast Ratio (CR) : Ratio of gray max (Gmax) ,gray min (Gmin) at 5 points(4, 5, 7, 9, 10)

$$CR = \frac{CR(4) + CR(5) + CR(7) + CR(9) + CR(10)}{5}$$

POINTS : (4) , (5) , (7) , (9) , (10) at FIGURE OF NOTE 6)

Note 3) Definition of Response time :

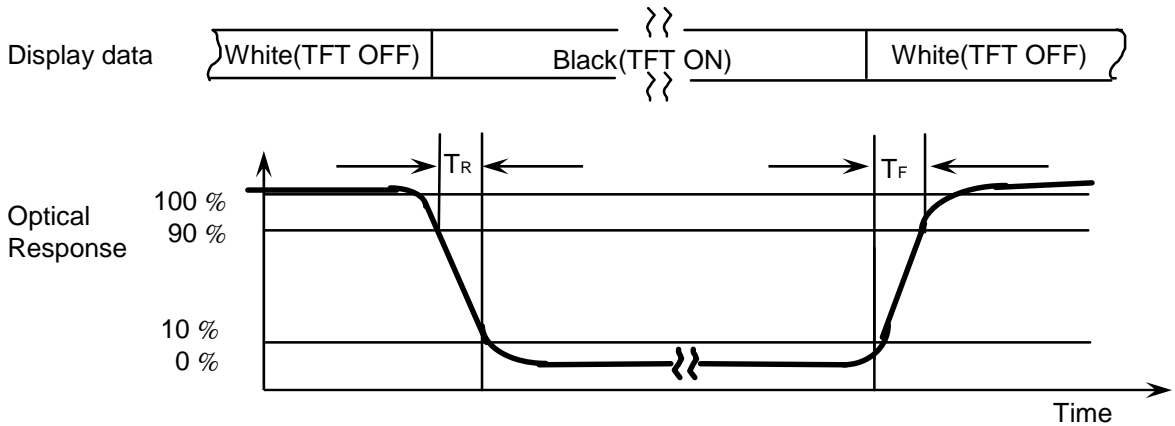

Note 4) Definition of Average Luminance of White : measure the luminance of white at 5 points.

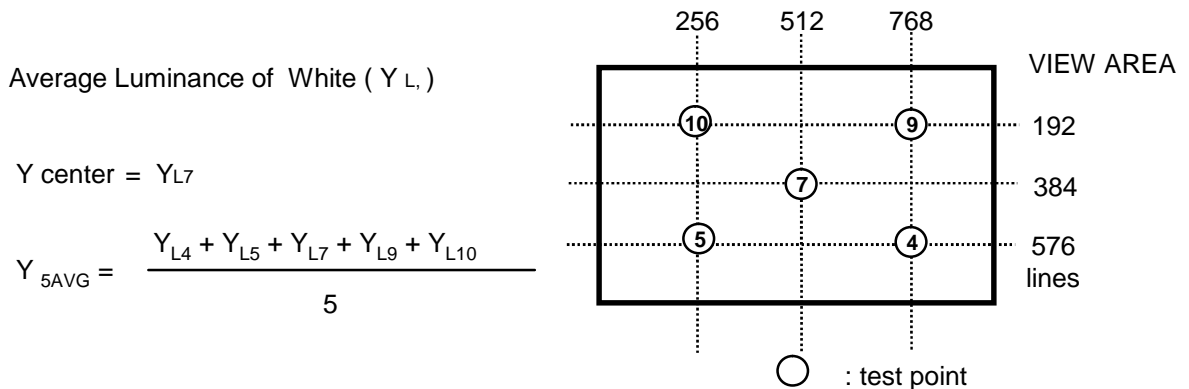

Note 5) After stabilizing and leaving the panel alone at a given temperature for 30 minutes, the measurement should be executed. Measurement should be executed in a stable, windless, and dark room. 30 minutes after lighting the back-light. This should be measured in the center of screen.

Environment condition : $T_a = 25 \pm 2 \text{ }^\circ\text{C}$

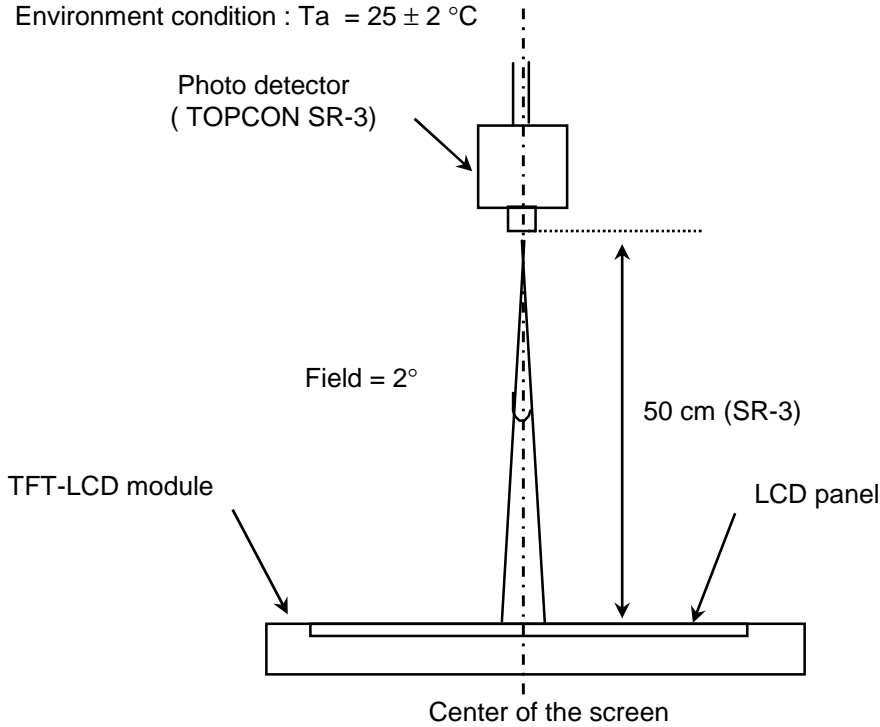

Optical characteristics measurement setup

Note 6) Definition of 13 points white variation (δ_w) [① ~ ⑬]

$$\delta_{13L} = \frac{\text{Minimum luminance of 13 points}}{\text{Maximum luminance of 13 points}}$$

Note 7) Definition of 5 points white variation (δ_w) [④ ⑤ ⑦ ⑨ ⑩]

$$\delta_{5L} = \frac{\text{Minimum luminance of 5 points}}{\text{Maximum luminance of 5 points}}$$

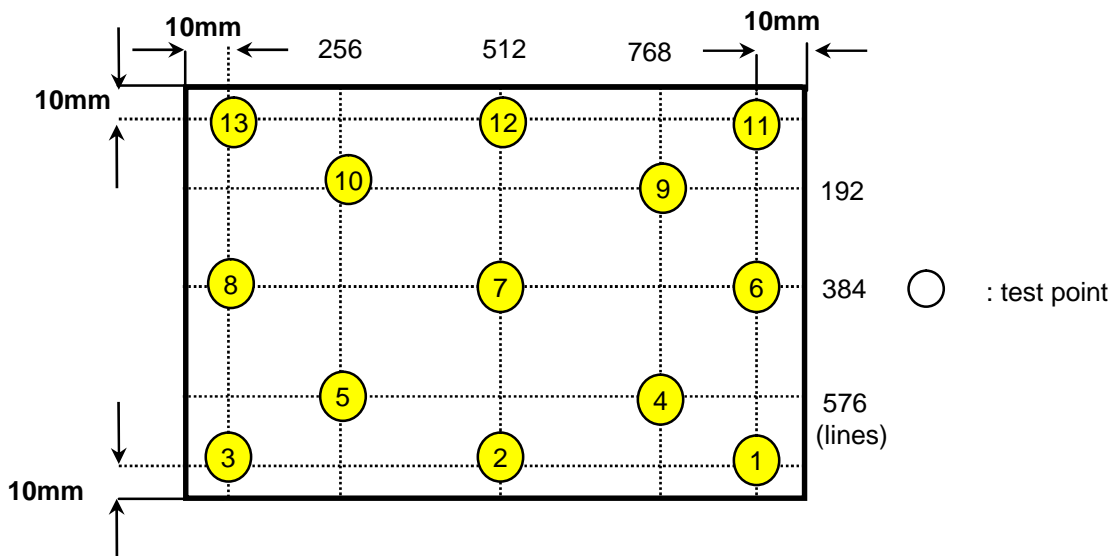

3. ELECTRICAL CHARACTERISTICS

3.1 TFT LCD MODULE

Ta=25 ± 2 °C

ITEM		Symbol	Min	Typ	Max	Unit	Note
Voltage of Power Supply		Vdd	3.0	3.3	3.6	V	
Differential Input voltage for LVDS Receiver Threshold	High	V _{IH}			+100	mV	V _{CM} =+1.2V
	Low	V _{IL}	-100			mV	
Vsync Frequency	50Hz	Hsync	F _H	-	40.3	-	KHz
		Main Freq.	F _{DCLK}	-	54.13	-	MHz
Rush Current		I _{RUSH}			1.5	A	(4)
Current of Power Supply	White	I _{DD}	-	270	-	mA	(2),(3) *a
	Mosaic		-	300	-	mA	(2),(3) *b
	WinXP Pattern		-	275	-	mA	(2),(3) *c
	Max Patter		-	-	360	mA	(2),(3) *d

Note (1) Display data pins and timing signal pins should be connected.(GND=0V)

(2) f_V=50Hz, f_{DCLK} =54.13MHZ, Vdd = 3.3V , DC Current.

(3) Power dissipation pattern

*a) White Pattern

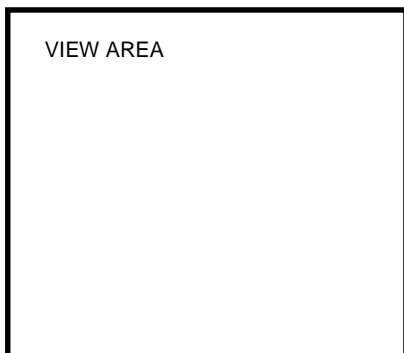

*b) Mosaic Pattern

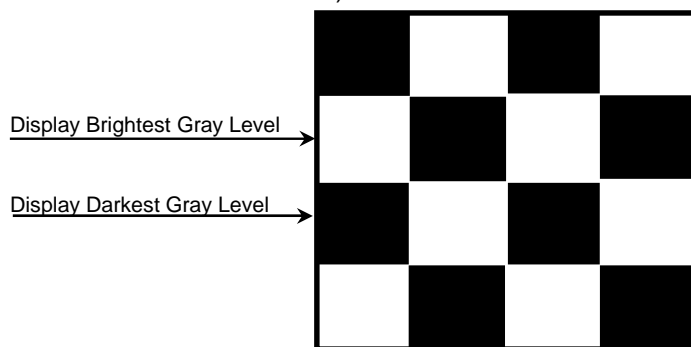

*c) WinXP Pattern (Hill pattern)



*d) 1dot Inversion Pattern

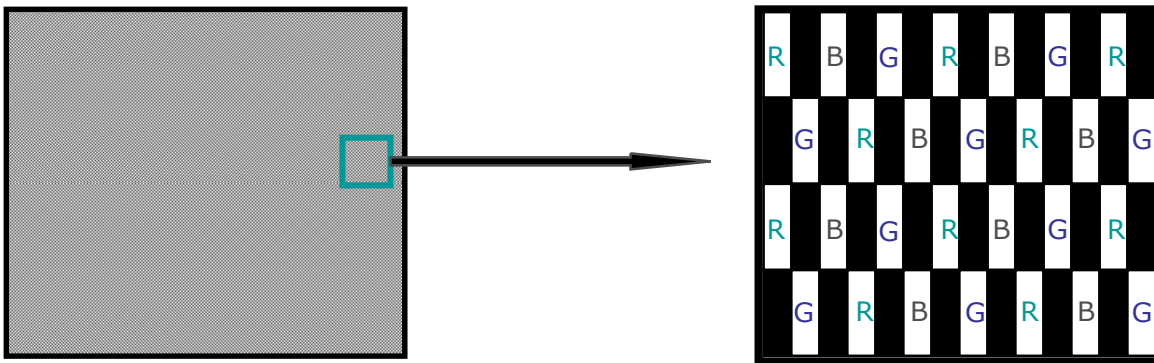

4) Rush current measurement condition

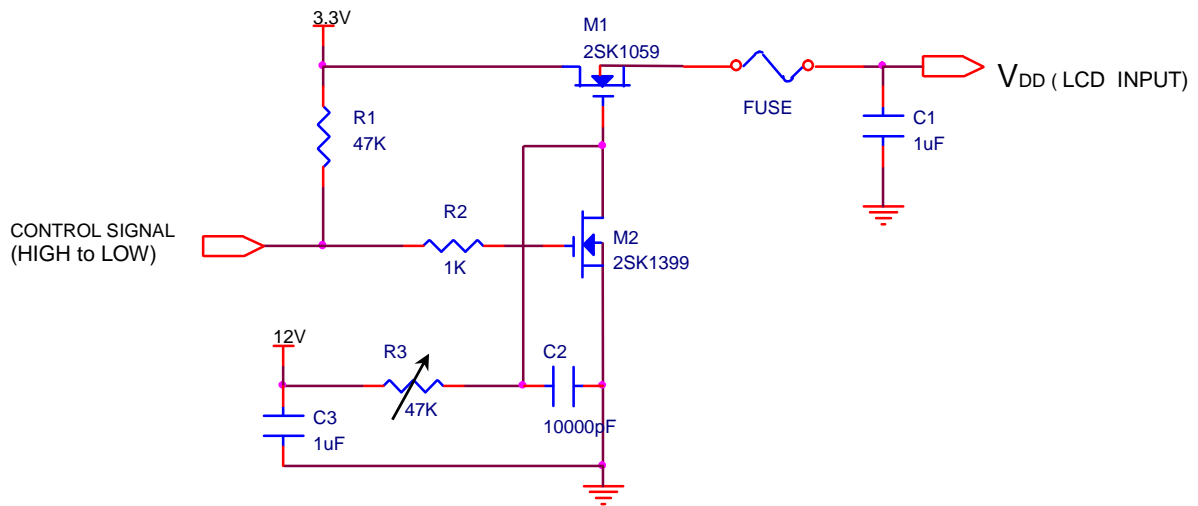

V_{DD} rising time is 470us

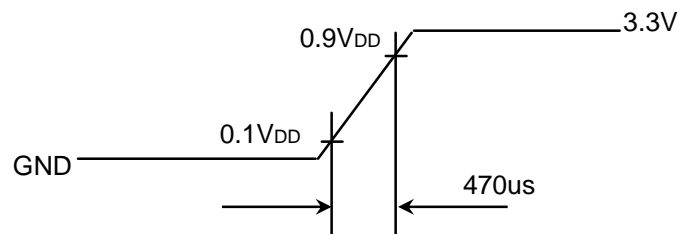

3.2 LED BACKLIGHT UNIT

(2) Backlight

ITEM	SYMBOL	MIN.	TYP.	MAX.	UNIT	Remarks
LED Voltage	VF	--	(24)	9.0	V	IF = 150 mA, Ta = 25°C, *2)
		--	--	10.0	V	IF = 150 mA, Ta = 0°C
		--	--	10.2	V	IF = 150 mA, Ta = -30°C
LED Current	IF	--	150	--	mA	Ta = 25°C, *1), *3)
LED Life Time	LT	30,000	--	--	h	IF = 150 mA, Ta = 25°C *4), *5), Continuous operation

[Note]

*1) Constant Current Drive

*2) The Voltage deviation between strings: $|V_{f1} - V_{f2}| \leq 2V$

*3) LED Current measurement method

*4) LED life time is defined as the time when the brightness becomes 50% of the initial value.

*5) The life time of the backlight depends on the ambient temperature. The life time will decrease under high temperature.

4. BLOCK DIAGRAM

4.1 TFT LCD MODULE

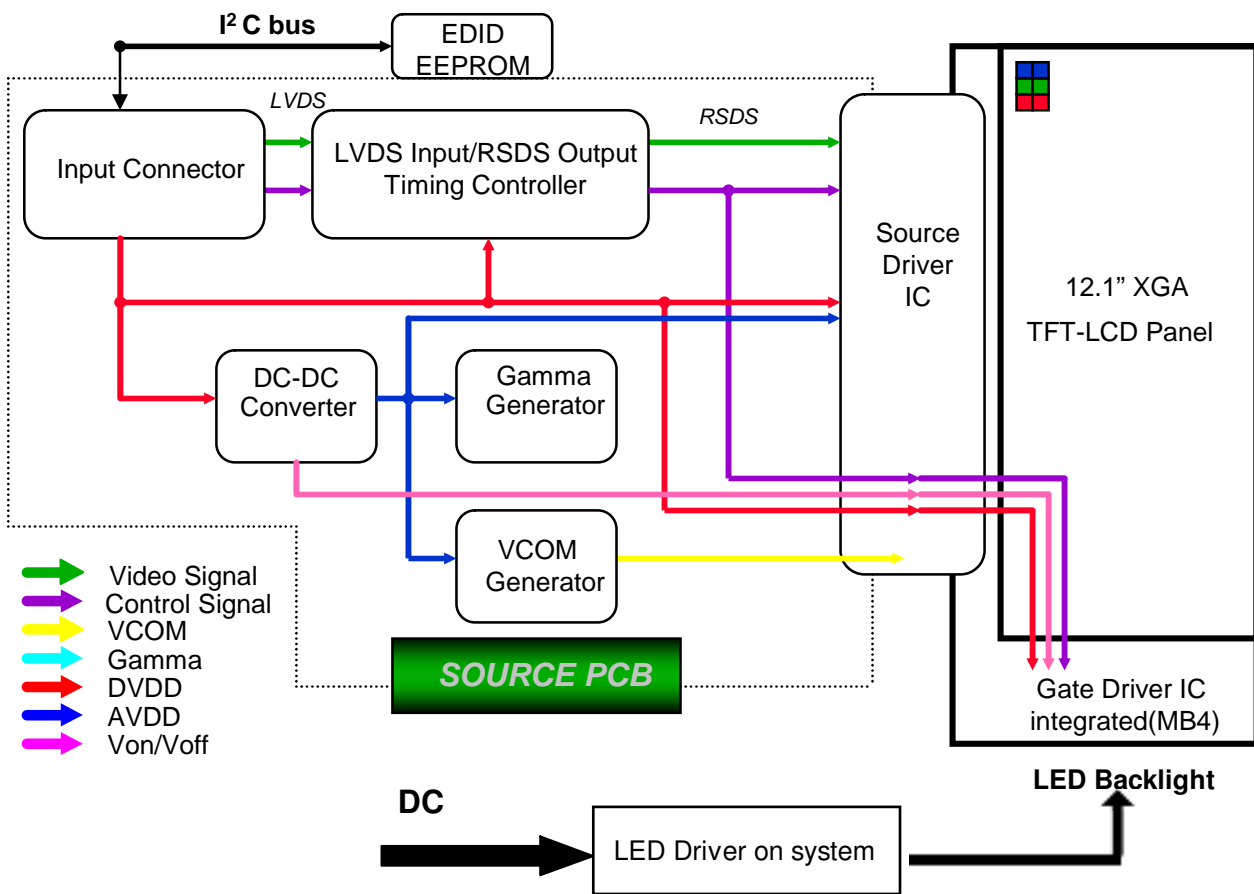

4.2 LED BACKLIGHT UNIT (Connector : H112K-P06N-00B)

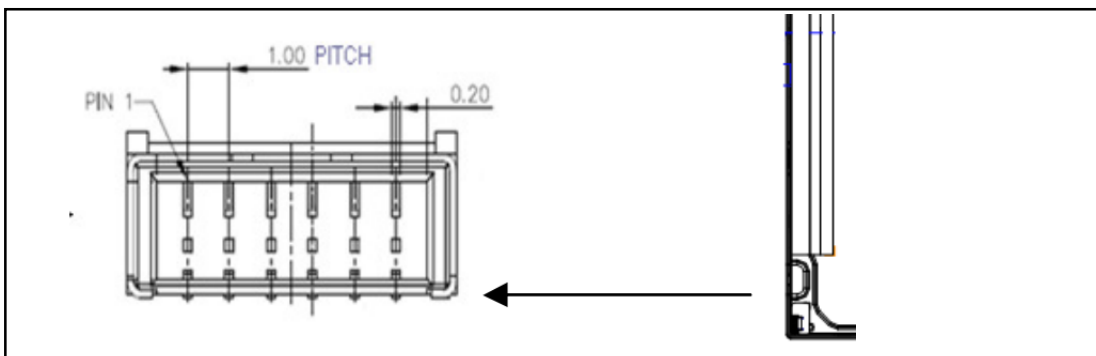

5. INPUT TERMINAL PIN ASSIGNMENT

5.1. Input Signal & Power (Connector : HIROSE, DF-19L-20P-1H
Mating Connector : HIROSE, DF19G-20S-1F)

Pin No.	Symbol	Function	Polarity	Remark
1	GND1	Ground	-	-
2	VDD1	Power Supply +3.3V	-	-
3	VDD2	Power Supply +3.3V	-	-
4	V EEDID	DDC 3.3V power	DDC 3.3V Power	-
5	N.C.	<i>Reserved for supplier test point</i>	-	-
6	Clk EEDID	DDC Clock	DDC clock	-
7	Data EEDID	DDC Data	DDC data	-
8	RxIN0-	Data LVDS Signal	Negative	-
9	RxIN0+	Data LVDS Signal	Positive	-
10	GND2	Power Ground	-	-
11	RxIN1-	Data LVDS Signal	Negative	-
12	RxIN1+	Data LVDS Signal	Positive	-
13	GND3	Power Ground	-	-
14	RxIN2-	Data LVDS Signal	Negative	-
15	RxIN2+	Data LVDS Signal	Positive	-
16	GND4	Power Ground	-	-
17	RxCLKIN-	Clock LVDS Signal	Negative	-
18	RxCLKIN+	Clock LVDS Signal	Positive	-
19	GND5	Power Ground	-	-
20	GND6	Power Ground	-	-

5.2 LVDS Interface : Transmitter DS90CF383 or Compatible

Pin No.	Name	RGB Signal	Pin No.	Name	RGB Signal
51	TxIN0	R0	14	TxIN14	G5
52	TxIN1	R1	15	TxIN15	B0
54	TxIN2	R2	19	TxIN18	B1
55	TxIN3	R3	20	TxIN19	B2
56	TxIN4	R4	22	TxIN20	B3
3	TxIN6	R5	23	TxIN21	B4
4	TxIN7	G0	24	TxIN22	B5
6	TxIN8	G1	27	TxIN24	Hsync
7	TxIN9	G2	28	TxIN25	Vsync
11	TxIN12	G3	30	TxIN26	DE
12	TxIN13	G4	31	TxCLKIN	Clock

FLAT LINK INTERFACE

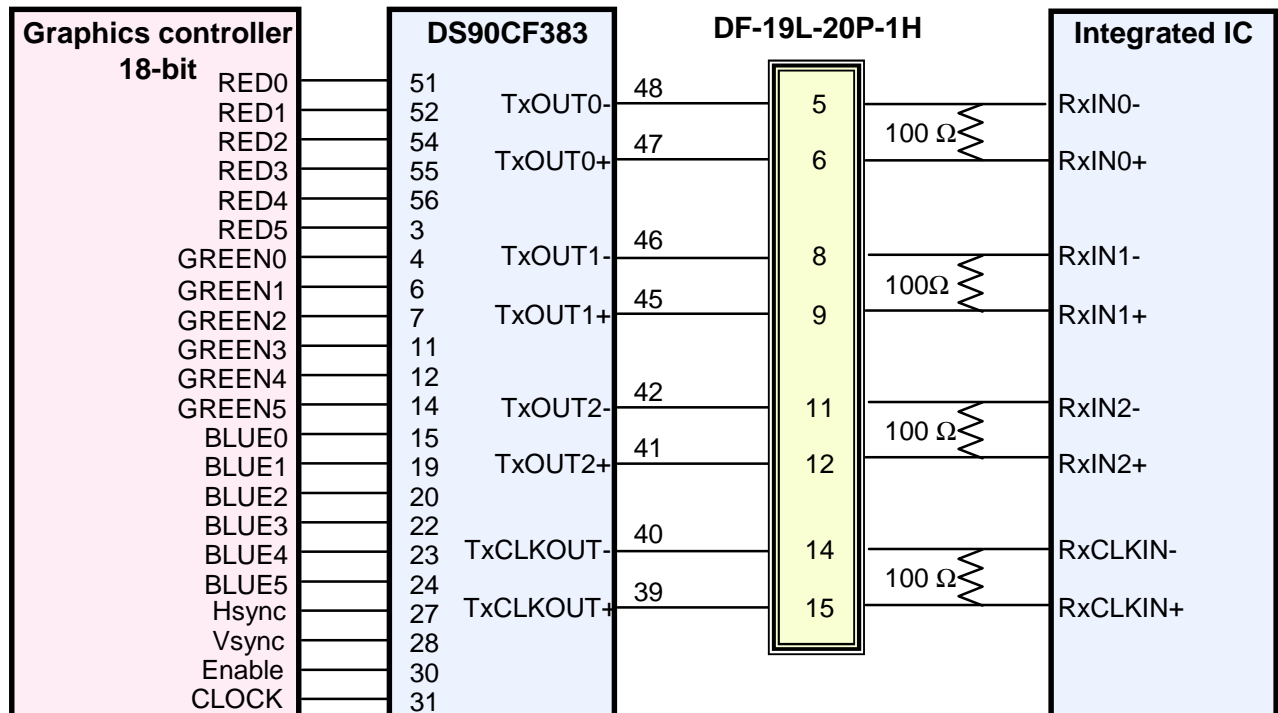

5.3 LED Pin assignment

Pin#	Signal Name
1	IRLED1 (current out)
2	IRLED2 (current out)
3	VLED (voltage in)
4	VLED (voltage in)
5	IRLED3 (current out)
6	IRLED4 (current out)

ENTERY Non-Locking type: H112K-P06N-00B

Locking type: H112K-P06N-03B

5.4 Timing Diagrams of LVDS For Transmission

LVDS Receiver : Integrated T-CON

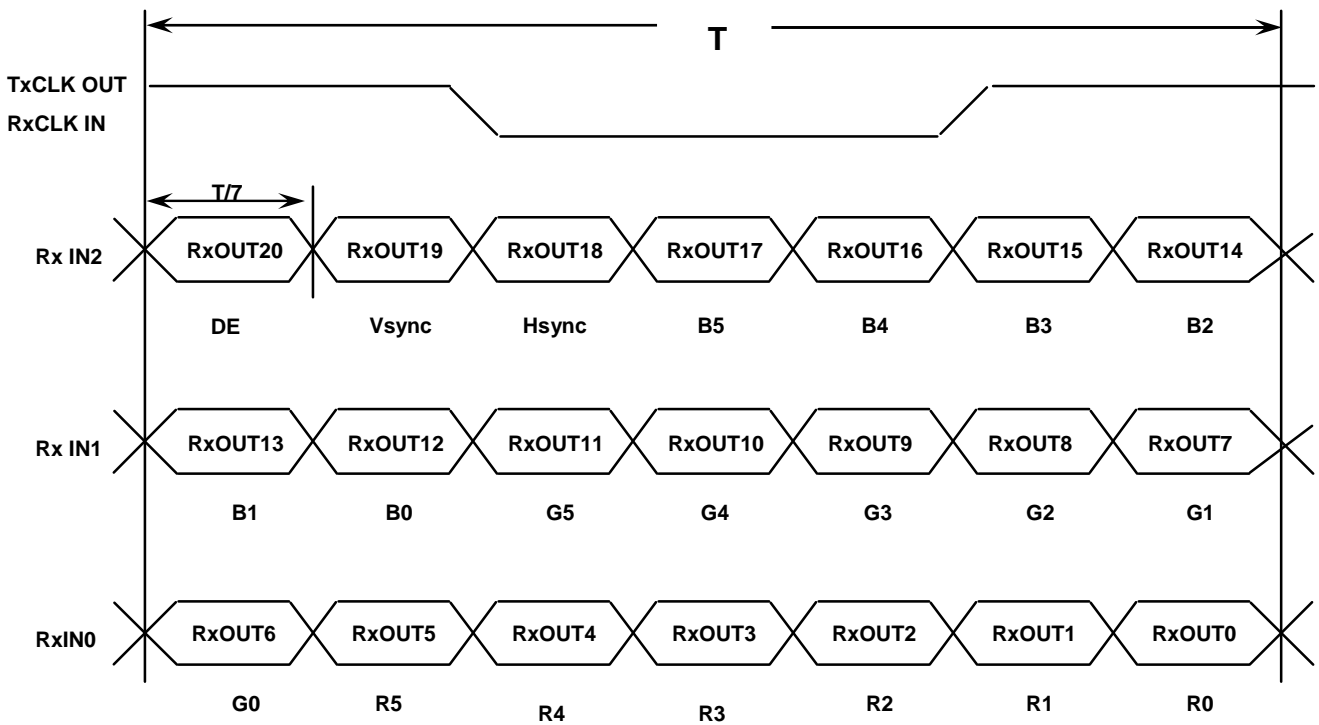

5.5 Input Signal, Basic Display Colors and Gray Scale of Each Colors

Color	Display	Data Signal																	Gray Scale Level	
		Red					Green					Blue								
		R0	R1	R2	R3	R4	R5	G0	G1	G2	G3	G4	G5	B0	B1	B2	B3	45		B5
Basic Colors	Black	0	0	0	0	0	0	0	0	0	0	0	0	0	0	0	0	0	0	-
	Blue	0	0	0	0	0	0	0	0	0	0	0	0	1	1	1	1	1	1	-
	Green	0	0	0	0	0	0	1	1	1	1	1	1	0	0	0	0	0	0	-
	Cyan	0	0	0	0	0	0	1	1	1	1	1	1	1	1	1	1	1	1	-
	Red	1	1	1	1	1	1	0	0	0	0	0	0	0	0	0	0	0	0	-
	Magenta	1	1	1	1	1	1	0	0	0	0	0	0	1	1	1	1	1	1	-
	Yellow	1	1	1	1	1	1	1	1	1	1	1	1	0	0	0	0	0	0	-
	White	1	1	1	1	1	1	1	1	1	1	1	1	1	1	1	1	1	1	-
Gray Scale Of Red	Black	0	0	0	0	0	0	0	0	0	0	0	0	0	0	0	0	0	R0	
	Dark	1	0	0	0	0	0	0	0	0	0	0	0	0	0	0	0	0	R1	
	↑	0	1	0	0	0	0	0	0	0	0	0	0	0	0	0	0	0	R2	
	:	:	:	:	:	:	:	:	:	:	:	:	:	:	:	:	:	:	R3-R60	
	:	:	:	:	:	:	:	:	:	:	:	:	:	:	:	:	:	:		
	↓	1	0	1	1	1	1	0	0	0	0	0	0	0	0	0	0	0	R61	
	Light	0	1	1	1	1	1	0	0	0	0	0	0	0	0	0	0	0	R62	
	Red	1	1	1	1	1	1	0	0	0	0	0	0	0	0	0	0	0	R63	
Gray Scale Of Green	Black	0	0	0	0	0	0	0	0	0	0	0	0	0	0	0	0	0	G0	
	Dark	0	0	0	0	0	0	1	0	0	0	0	0	0	0	0	0	0	G1	
	↑	0	0	0	0	0	0	0	1	0	0	0	0	0	0	0	0	0	G2	
	:	:	:	:	:	:	:	:	:	:	:	:	:	:	:	:	:	:	G3-G60	
	:	:	:	:	:	:	:	:	:	:	:	:	:	:	:	:	:	:		
	↓	0	0	0	0	0	0	1	0	1	1	1	1	0	0	0	0	0	G61	
	Light	0	0	0	0	0	0	0	1	1	1	1	1	0	0	0	0	0	G62	
	Green	0	0	0	0	0	0	1	1	1	1	1	1	0	0	0	0	0	G63	
Gray Scale Of Blue	Black	0	0	0	0	0	0	0	0	0	0	0	0	0	0	0	0	0	B0	
	Dark	0	0	0	0	0	0	0	0	0	0	0	1	0	0	0	0	0	B1	
	↑	0	0	0	0	0	0	0	0	0	0	0	0	1	0	0	0	0	B2	
	:	:	:	:	:	:	:	:	:	:	:	:	:	:	:	:	:	:	B3-B60	
	:	:	:	:	:	:	:	:	:	:	:	:	:	:	:	:	:	:		
	↓	0	0	0	0	0	0	0	0	0	0	0	0	1	0	1	1	1	B61	
	Light	0	0	0	0	0	0	0	0	0	0	0	0	0	1	1	1	1	B62	
	Blue	0	0	0	0	0	0	0	0	0	0	0	0	1	1	1	1	1	B63	

Note

(1) Definition of Gray : Rn : Red Gray, Gn : Green Gray, Bn : Blue Gray (n = Gray level)

(2) Input Signal : 0 = Low level voltage, 1 = High level voltage

5.6 PIXEL FORMAT

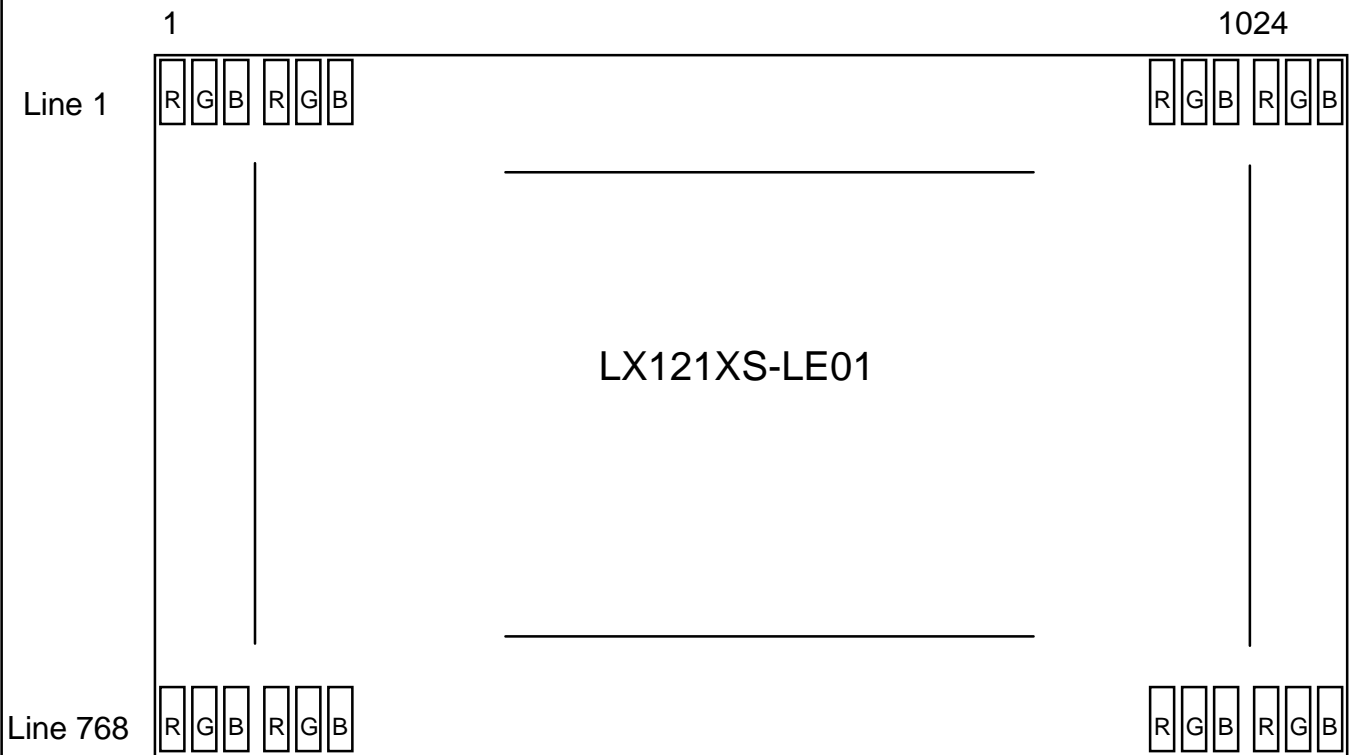

6. INTERFACE TIMING

6.1 Timing Parameters

Signal	Item	Symbol	Min.	Typ.	Max.	Unit	Note
Frame Frequency	Cycle	T_V	-	806	-	Lines	-
Vertical Active Display Term	Display Period	T_{VD}	-	768	-	Lines	-
One Line Scanning Time	Cycle	T_H	-	1344	-	Clocks	-
Horizontal Active Display Term	Display Period	T_{HD}	-	1024	-	Clocks	-
Vertical Blank Term	Cycle	V_{blank}		6		lines	
Horizontal Blank Term	Cycle	H_{blank}		32		clocks	

6.2 Timing diagrams of interface signal

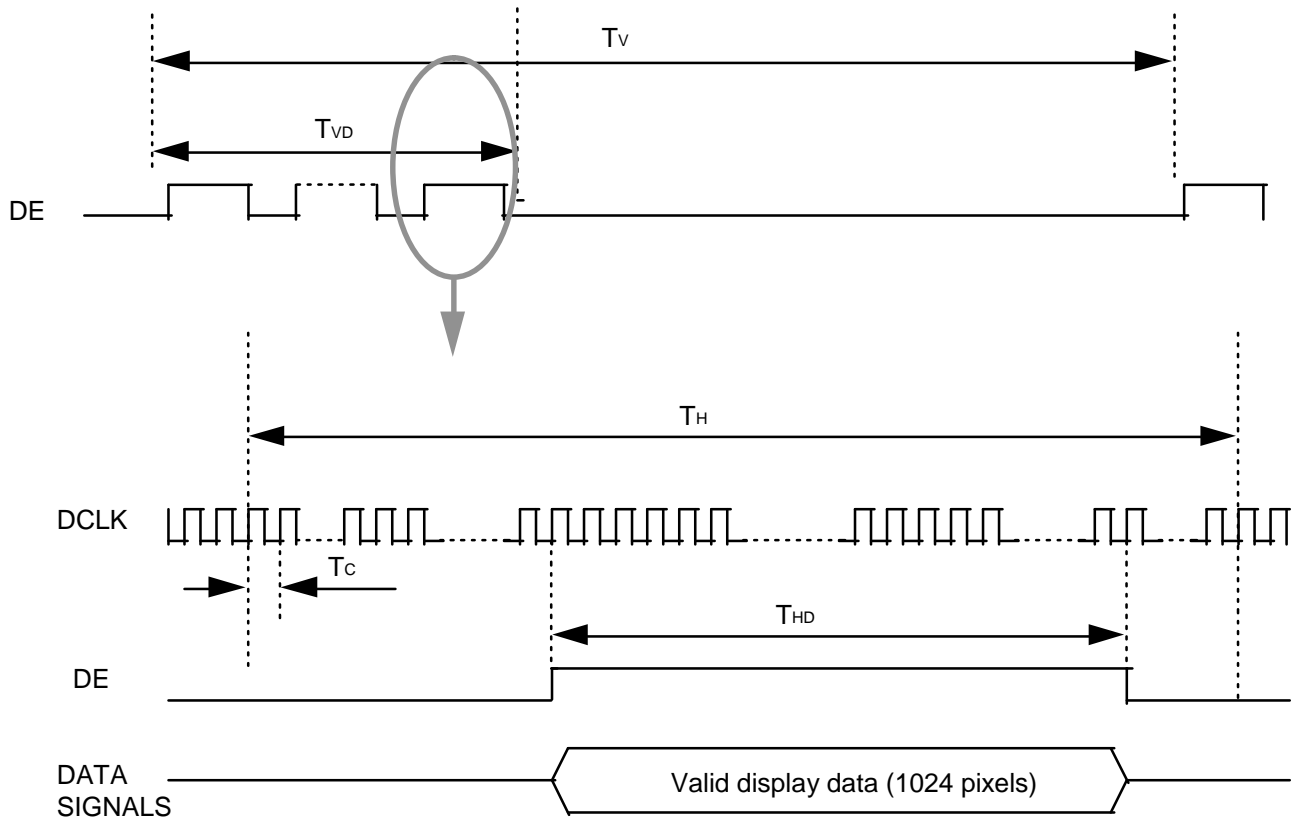

Note

(1) All input condition(level&timing) for LX01812 are the same with those of NS DS90CF384 or compatible.

6.3 Power ON/OFF Sequence

: To prevent a latch-up or DC operation of the LCD module, the power on/off sequence shall be as shown below.

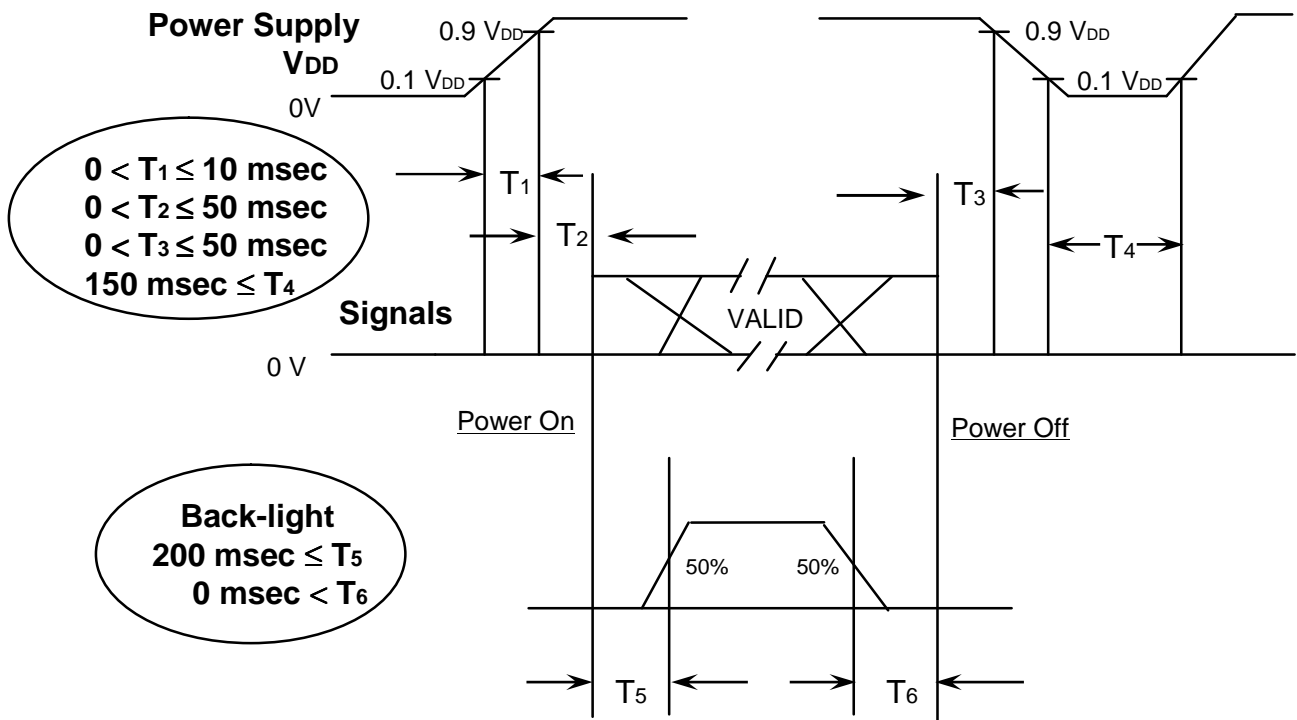

Power ON/OFF Sequence

- T1 : Vdd rising time from 10% to 90%
- T2 : The time from Vdd to valid data at power ON.
- T3 : The time from valid data off to Vdd off at power Off.
- T4 : Vdd off time for Windows restart
- T5 : The time from valid data to B/L enable at power ON.
- T6 : The time from valid data off to B/L disable at power Off.

NOTE.

- (1) The supply voltage of the external system for the module input should be the same as the definition of VDD.
- (2) Apply the backlight within the LCD operation range. When the backlight turns on before the LCD operation or the LCD turns off before the backlight turns off, the display may momentarily become white.
- (3) In case of VDD = off level, please keep the level of input signals on the low or keep a high impedance.
- (4) T4 should be measured after the module has been fully discharged between power off and on period.
- (5) Interface signal shall not be kept at high impedance when the power is on.

7. Mechanical Outline Dimension

[Refer to the next page]

8. PACKING

1. CARTON(Internal Package)

(1) Packing Form

Corrugated Cardboard box and Corrupad form as shock absorber

(2) Packing Method



- Note 1) Total Weight : Approximately 13.6 kg
2) Acceptance number of piling : 20 sets
3) Carton size : 520mm × 270mm × 325mm
4) MAX accumulation quantity : 4 cartons

No	Part name	Quantity
1	Static electric protective sack	10
2	Packing case(Inner box) included shock absorber	1 set
3	Pictorial marking	2 pics
4	Carton	1 set

9. MARKINGS & OTHERS

A nameplate bearing followed by is affixed to a shipped product at the specified location on each product.

(1)Parts number : LX121XS-LE01

(2)Revision : One letter

(3)Control code : One letter

(4)Lot number : 3 S 16 F 053 11 F

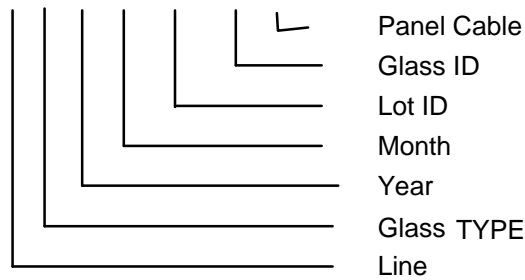

NOTE 1). This code indicating year is omitted in the products of Chun-an site.

(5) Product Label Definition

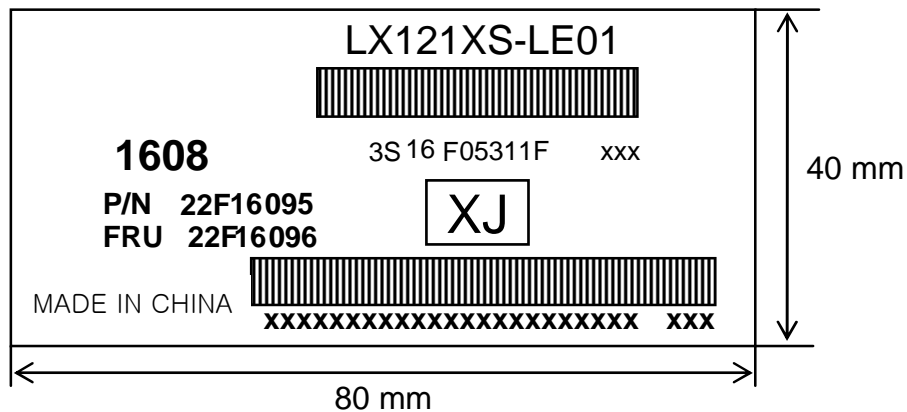

TFT-LCD Product name : LX121XS-LE01
Lot number :
Revision Code : xxx
Inspected work week : 1608(2016 Year, 8nd week)

(6) Packing box attach

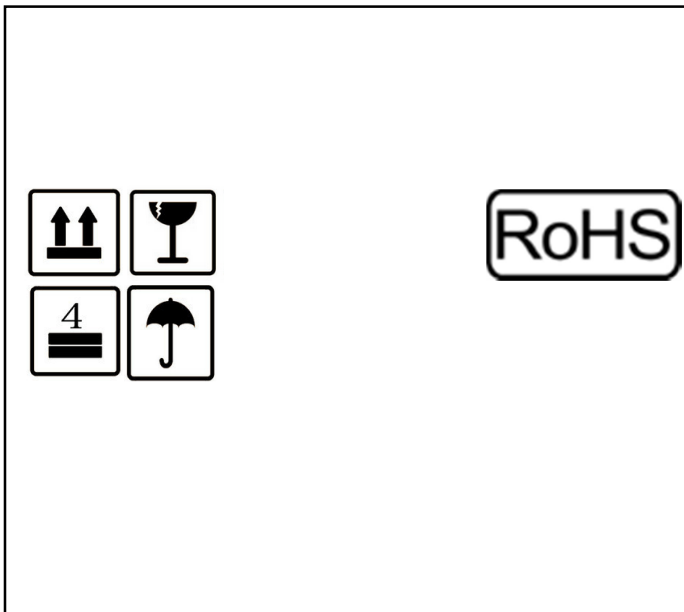

10. GENERAL PRECAUTIONS

1. Handling

- (a) When the module is assembled, It should be attached to the system firmly using selected mounting holes. Be careful not to twist and bend the modules.
- (b) Refrain from strong mechanical shock and / or any force to the module. In addition to damage, this may cause improper operation or damage to the module and **LED** backlight.
- (c) Note that polarizers are very fragile and could be easily damaged. Do not press or scratch the surface harder than a HB pencil lead.
- (d) Wipe off water droplets or oil immediately. If you leave the droplets for a long time, Staining and discoloration may occur.
- (e) If the surface of the polarizer is dirty, clean it using some absorbent cotton or soft cloth.
- (f) The desirable cleaners are water, IPA(Isopropyl Alcohol) or Hexane. Do not use Ketone type materials(ex. Acetone), Ethyl alcohol, Toluene, Ethyl acid or Methyl chloride. It might permanent damage to the polarizer due to chemical reaction.
- (g) If the liquid crystal material leaks from the panel, it should be kept away from the eyes or mouth. In case of contact with hands, legs or clothes, it must be washed away thoroughly with soap.
- (h) Protect the module from static, it may cause damage to the C-MOS Gate Array IC.
- (i) Use fingerstalls with soft gloves in order to keep display clean during the incoming inspection and assembly process.
- (j) Do not disassemble the module.
- (k) Do not pull or fold the **LED** wire.
- (l) Do not adjust the variable resistor which is located on the back side.
- (m) Protection film for polarizer on the module shall be slowly peeled off just before use so that the electrostatic charge can be minimized.
- (n) Pins of I/F connector shall not be touched directly with bare hands.

2. STORAGE

- (a) Do not leave the module in high temperature, and high humidity for a long time. It is highly recommended to store the module with temperature from 0 to 35°C and relative humidity of less than 70%.
- (b) Do not store the TFT-LCD module in direct sunlight.
- (c) The module shall be stored in a dark place. It is prohibited to apply sunlight or fluorescent light during the store.

3. OPERATION

- (a) Do not connect, disconnect the module in the “ Power On” condition.
- (b) Power supply should always be turned on/off by following item 6.3 “ Power on/off sequence “.
- (c) Module has high frequency circuits. Sufficient suppression to the electromagnetic interference shall be done by system manufacturers. Grounding and shielding methods may be important to minimize the interference.
- (d) The cable between the backlight connector and its inverter power supply shall be a minimized length and be connected directly . The longer cable between the backlight and the inverter may cause lower luminance of backlight(LED) and may require higher startup voltage(Vs).

4. OTHERS

- (a) Ultra-violet ray filter is necessary for outdoor operation.
- (b) Avoid condensation of water. It may result in improper operation or disconnection of electrode.
- (c) Do not exceed the absolute maximum rating value. (the supply voltage variation, input voltage variation, variation in part contents and environmental temperature, so on) Otherwise the module may be damaged.
- (d) If the module displays the same pattern continuously for a long period of time, it can be the situation when the image “sticks” to the screen.
- (e) This module has its circuitry PCB's on the rear side and should be handled carefully in order not to be stressed.

