

**DESCRIPTION**

The LX1736 operates as a Current Mode PWM Buck regulator that switches to PFM mode under light loads. The entire regulator function is implemented with only a few, low-cost external components.

The LX1736 responds quickly to dynamic load changes using a high bandwidth error amplifier and internal compensation. Tight output voltage regulation is maintained with the temperature compensated 800mV, bandgap reference achieving +/-3.5% regulation tolerance for all line, load and thermal conditions. The output voltage is easily programmed, from 800mV to 90% of  $V_{IN}$  with two external resistors

The regulator is capable of providing an output load current up to 1.25A and has no minimum load current requirement for stable operation. Current limit senses on a cycle-by cycle basis to protect the switch. Power conversion efficiency is maximized with PFM mode of operation and low regulator quiescent current.

The LX1736 operational supply voltage range covers 4.0V to 6.0V, features include: power on delay; soft start to limit inrush currents and thermal shutdown during fault conditions.

The 6-pin JEDEC MO-229 package provides a small form factor and low profile at 3x3x1mm with excellent power dissipation capability on surface mount PCB's.

**IMPORTANT:** For the most current data, consult MICROSEMI's website: <http://www.microsemi.com>

**KEY FEATURES**

- Few External Components
- 800mV Internal Reference
- Tight Regulation over Line, Load and Temperature
- 4.5V to 5.5V Input Range
- Internal Soft Start Controls Inrush Current
- High Efficiency
- Low Quiescent Current, 600µA
- Fully Fault Protected
- Thin MO-229, 6-Pin Package

**APPLICATIONS**

- Point of Load Regulation
- DSP, ASIC and Core Voltage Supplies
- Hard Disk Drives
- Set Top Boxes
- RoHS compliant product

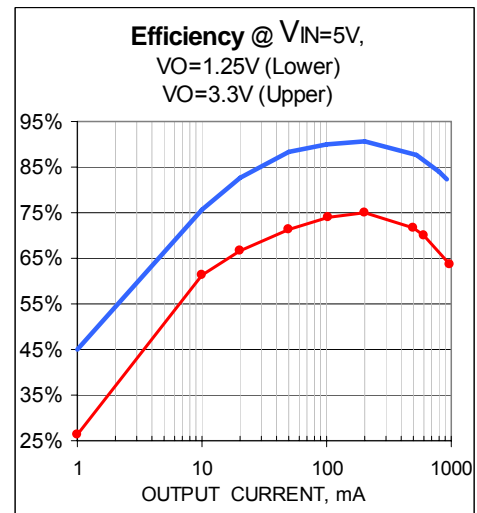
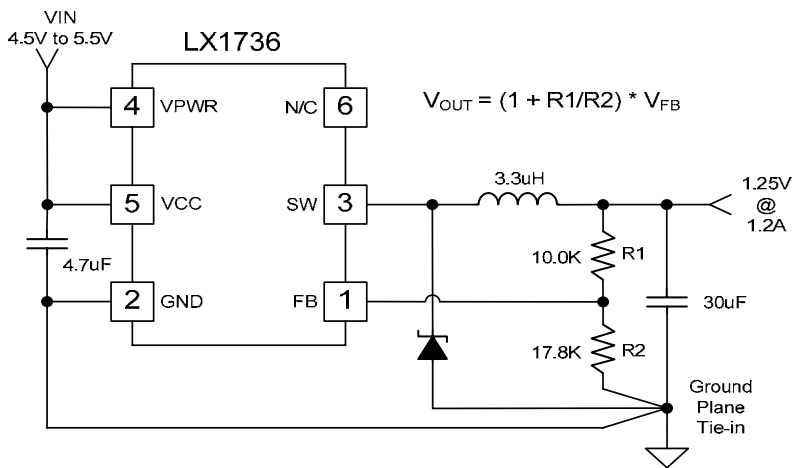
**PRODUCT HIGHLIGHT**

**Figure 1 – LX1736 Application Circuit and Typical Efficiency Performance**

**PACKAGE ORDER INFO**

$T_A$ (°C)	<b>LD</b> Plastic MLPD 6 pin 3mm x 3mm RoHS Compliant / Pb-free
	0 to 125 <b>LX1736CLD</b>
Note: Available in Tape & Reel. Append the letters "TR" to the part number. (i.e. LX1736CLD-TR)	

**Package Marking**

**ABSOLUTE MAXIMUM RATINGS**

Input Voltage (VCC or VPWR).....	-0.3V to 7.0V
SW to GND.....	-0.3V to (V <sub>IN</sub> + 0.3V)
VFB to GND.....	-0.3V to +2V
SW Peak Current .....	Internally Limited
Junction Operating Temperature Range.....	0°C to +125°C
Storage Temperature Range, T <sub>A</sub> .....	-65°C to 150°C
Maximum Junction Temperature .....	150°C
Package Peak Temp. for Solder Reflow (40 seconds max. exposure).....	260°C (+0, -5)

Note: Exceeding these ratings could cause damage to the device. All voltages are with respect to Ground. Currents are positive into, negative out of specified terminal.

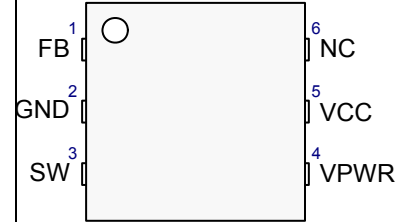
**PACKAGE PIN OUT**

**LD PACKAGE**  
(Top View)

RoHS / Pb-free 100% matte Tin Pin Finish

**THERMAL DATA**
**LD Plastic MLP 3x3mm MO-229, 6-Pin**

<b>THERMAL RESISTANCE-JUNCTION TO CASE, <math>\theta_{JC}</math></b>	<b>4°C/W</b>
<b>THERMAL RESISTANCE-JUNCTION TO AMBIENT, <math>\theta_{JA}</math></b>	<b>25 to 50°C/W</b>

Junction Temperature Calculation:  $T_J = T_A + (P_D \times \theta_{JA})$ .

The  $\theta_{JA}$  numbers are guidelines for the thermal performance of the device/pc-board system. All of the above assume no ambient airflow.

**FUNCTIONAL PIN DESCRIPTION**

Name	Pin #	Description
VCC	5	Unregulated supply voltage input, ranging from +4V to 6.0V for internal analog control circuitry.
VPWR	4	Unregulated supply voltage input (+4V to 6.0V), high current path, supplies PMOSFET Drain of PWM switch.
FB	1	Feedback input for setting programming output voltage.
GND	2	Circuit ground for IC analog circuitry and high frequency gate drive bias, exposed pad area on bottom of package may be connected to ground or left floating.
SW	3	Inductor and commutation diode connection point. Connects to internal PMOSFET Source of PWM Switch output.

**RECOMMENDED OPERATING CONDITIONS**

Parameter	Symbol	LX1736			Unit
		Min	Typ	Max	
Input Operating Voltage Range	V <sub>IN</sub>	4.5		5.5	V
Continuous Output Current Range	I <sub>OUT</sub>	0		0.9	A
Output Voltage Range	V <sub>OUT</sub>	0.8		80% of V <sub>IN</sub>	V
Operating Junction Temperature	T <sub>J</sub>	0		125	°C

**ELECTRICAL CHARACTERISTICS**

Specifications are guaranteed over the junction temperature range of:  $0^{\circ}\text{C} < T < 125^{\circ}\text{C}$  for  $V_{\text{IN}} = 4.5\text{V}$  to  $5.5\text{V}$  (unless noted otherwise), not all of these parameters are production tested but are assured by design, characterization and correlation with statistical process controls.. Typical values are at  $T_{\text{A}}=23^{\circ}\text{C}$ .

Parameter	Symbol	Test Conditions	LX1736			Units
			Min	Typ	Max	
Feedback Threshold	$V_{\text{FBT}}$	$4.0\text{V} < V_{\text{IN}} < 6.0\text{V}$	772	800	828	mV
Feedback Input Current	$I_{\text{FB-IN}}$	$V_{\text{FB}} = V_{\text{FBT}} + 10\text{mV}$			75	nA
PWM Frequency	$F_{\text{OP-PWM}}$	PWM Mode	800		1450	Khz
PFM Mode Transition	IO-PFM	PFM mode		80		mA
Minimum DC Output Current	$I_{\text{OUT}}$		0			mA
Maximum DC Output Current	$I_{\text{OUTMAX}}$	$T_{\text{J}} \leq 70^{\circ}\text{C}$			1.25 or 0.7/duty cycle whichever is less	A
Maximum Duty Cycle	$D_{\text{MAX}}$	$I_{\text{SW}} = I_{\text{OUT max}}$	80			%
Closed Loop Load Regulation	$V_{\text{OUT Load REG}}$	$10\text{mA} < I_{\text{OUT}} < I_{\text{OUT MAX}}$	-0.5		0.5	% $V_{\text{OUT}}$
Efficiency	$\eta$	$V_{\text{IN}}=5\text{V}, V_{\text{OUT}} \geq 1.1\text{V}, I_{\text{OUT}}=10\text{mA}$	55			%
		$V_{\text{IN}}=5\text{V}, V_{\text{OUT}} > 1.1\text{V}, I_{\text{OUT}} \geq 150\text{mA}$	70			%
Quiescent Current	$I_{\text{Q}}$	$V_{\text{FB}} = V_{\text{FBT}} + 10\text{mV}$		600	900	$\mu\text{A}$
P-Channel Switch ON Resistance	$R_{\text{DS(ON)}}$	$I_{\text{SW}} = 0.9\text{A}$		0.375		$\Omega$
P-Channel Switch Current Limit	$I_{\text{SW CL}}$	Peak Current at Switch Pin (Not DC Current)	1.1			A
		$T_{\text{J}} \leq 70^{\circ}\text{C}$	1.4			
P-Channel Switch Leakage	$I_{\text{SW LKG}}$	$V_{\text{FB}} = V_{\text{FBT}} + 10\text{mV}$			5	$\mu\text{A}$
Soft Start, $V_{\text{OUT}}$ Slew Rate	$V_{\text{O-SR}}$	Initial Power On or After a Short Circuit, $C_{\text{OUT}} = 20\mu\text{F}$		21	50	V/ms
Thermal Shutdown	$T_{\text{SD}}$	(Silicon Temperature)	135	150		$^{\circ}\text{C}$
DC Average In-Rush Current at VCC and VPWR (summed)	$I_{\text{INRUSH}}$	$V_{\text{IN}}$ ramping from 0V to 5V having a slew rate of 0.1V/S min to 0.5V/uS max and $C_{\text{OUT}} = 20\mu\text{F}$			550	mA
Output Voltage Overshoot (From either removal of a short circuit condition from $V_{\text{OUT}}$ or applied power during start up)	$V_{\text{O OS}}$	Applied power $V_{\text{IN}}$ ramp rate of 0.1V/S min to 0.5V/uS max			5	%
Output Voltage Response to Dynamic Load Change	$V_{\text{O OS}}$	Output load current change from 100ma to 700ma or 700ma to 100ma, transition time <100ns	-5		5	%
Circuit Output Capacitance	$C_{\text{OUT}}$	Closed Loop stability	20			$\mu\text{F}$

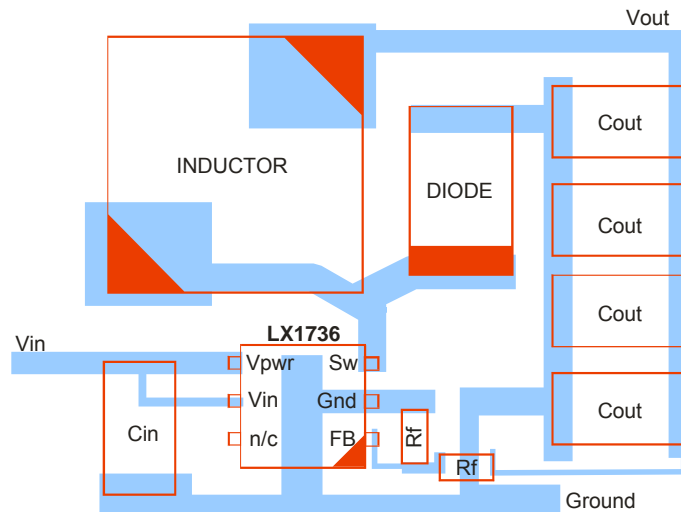
**APPLICATION SUPPORT**

**PCB Layout Considerations**

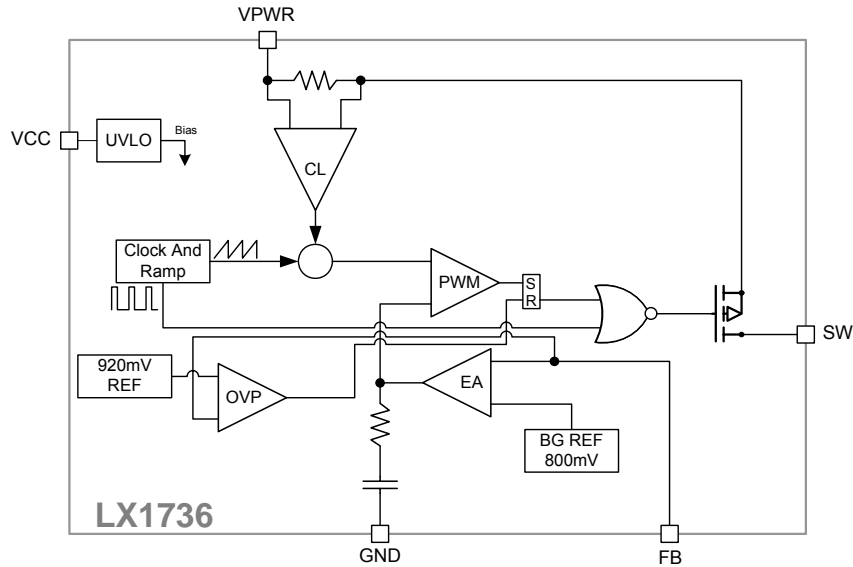
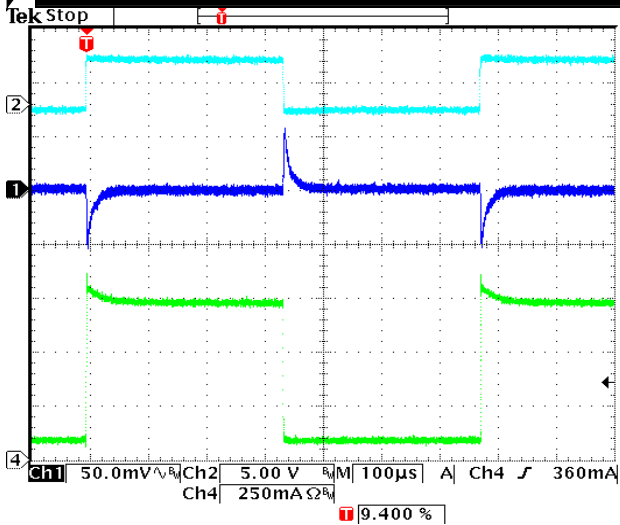
- 1- Maintain separate traces leading from the decoupling capacitor,  $C_{IN}$ , to the supply input pins of the IC for VCC and VPWR. This ensures that the noise and voltage drops associated with the high  $dI/dt$  pulses from the PWM switching are minimized for the internal control circuitry of the IC.
- 2- Diode ground should return to  $C_{OUT}$  ground with minimum physical distance before joining the IC Ground connection.
- 3- Feed back resistor return path to ground should be located closely to the IC Pin 2 to avoid  $V_{OUT}$  offsets induced by ground drops and noise.

**SIMPLIFIED BLOCK DIAGRAM**

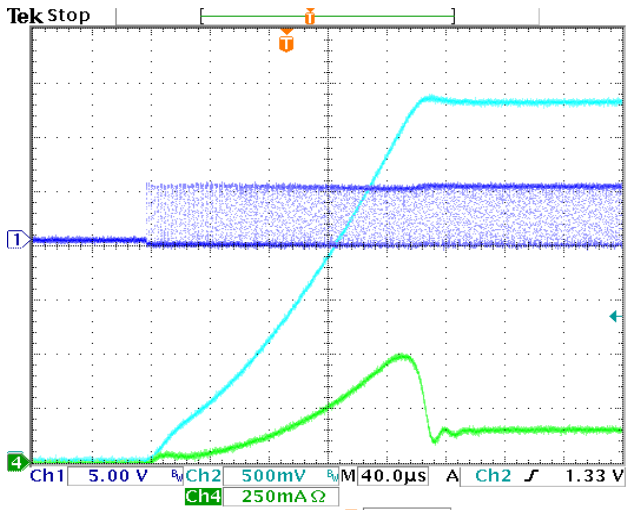
**APPLICATION PERFORMANCE**

Dynamic Load Change Response

CH1 = Vout AC Coupled  
 CH2 = Load Switch  
 CH4 = Output Current, 100mA to 750mA  
 $V_{IN}=5V, L=3.3\mu H, C_{OUT} = 20\mu F$

Start-up Inrush Current Control

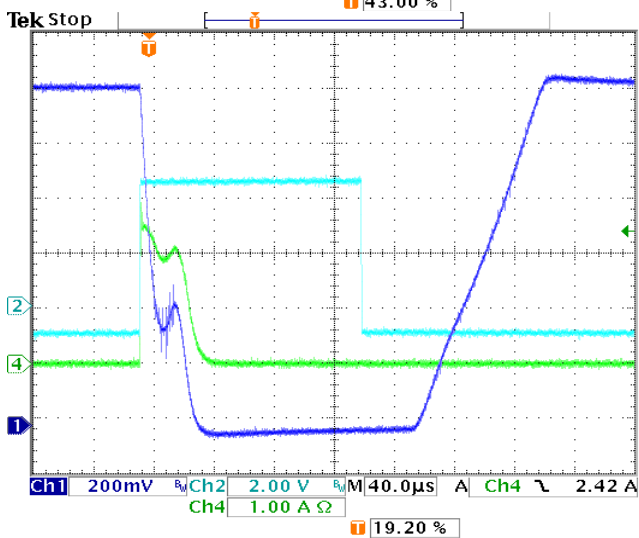
CH1 = SW Pin  
 CH2 = Vout @ 3.32V  
 CH4 = Input Current

$V_{IN}$ =5V, No Output load,  $C_{OUT}$  = 20 $\mu$ F

VOUT Response to Short Circuit Removal

CH1 = Vout programmed at 1.2V  
 CH2 = Short CKT Duration  
 CH4 = Output Current

$C_{OUT}$  = 20 $\mu$ F

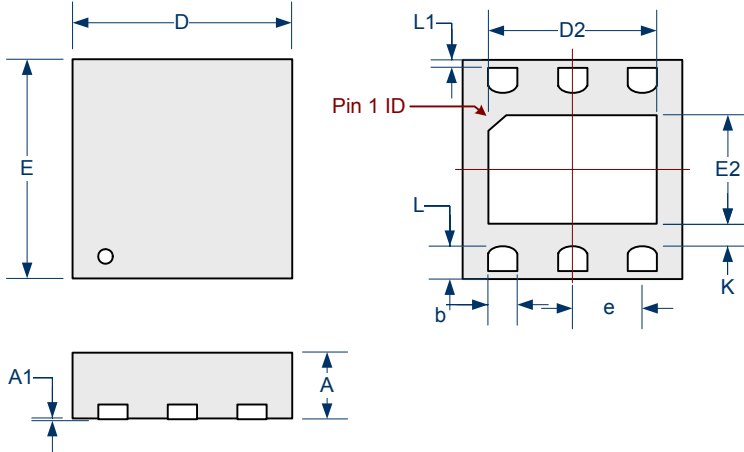
**PACKAGE DIMENSIONS**
**LD MO-229 6-Pin Plastic 3 x 3 x .9 mm**

Dim	MILLIMETERS		INCHES	
	MIN	MAX	MIN	MAX
A	0.80	1.00	0.031	0.039
A1	0.00	0.05	0.000	0.002
K	0.20 MIN		0.008 MIN	
e	0.95 BSC		0.037 BSC	
L	0.30	0.50	0.012	0.020
b	0.30	0.45	0.012	0.018
D2	1.90	2.40	0.075	0.094
E2	1.15	1.65	0.045	0.065
D	3.00 BSC		0.118 BSC	
E	3.00 BSC		0.118 BSC	
L1	0.00	0.15	0.000	0.006

**Note:**

1. Dimensions do not include mold flash or protrusions; these shall not exceed 0.155mm(.006") on any side. Lead dimension shall not include solder coverage.
2. Exposed heatsink pad on bottom may be left floating or connected to ground.

**NOTES**

PRODUCTION DATA – Information contained in this document is proprietary to Microsemi and is current as of publication date. This document may not be modified in any way without the express written consent of Microsemi. Product processing does not necessarily include testing of all parameters. Microsemi reserves the right to change the configuration and performance of the product and to discontinue product at any time.