

DESCRIPTION

The LX2205 is a complete single cell Lithium Ion or Lithium Polymer battery charger and power source manager. In addition to battery charging, power flow control is provided from up to three sources: a wall adapter, a standard USB power plug or the battery.

The battery charge current and termination current are independently adjustable. The controller also includes status indicators which show when the controller is powered by an external adapter in addition to charge in progress, and charge completed.

The USB input is current limited at

two logically selectable levels (100mA and 500mA). When powered by a USB input, the battery is charged with the excess USB current that is not consumed by the system load. If the load exceeds the USB current limit, the battery will discharge to assist the USB power source to power the load. The controller can logically suspend the USB power to allow the system to operate from the battery without loading the USB.

When a wall adapter is applied, it takes precedent over the USB power input and disables the USB input to prevent current flow from the adapter to the USB port.

IMPORTANT: For the most current data, consult *MICROSEMI's* website: <http://www.microsemi.com>
Patents Pending.

KEY FEATURES

- Single Cell Li-Ion Battery Charger
- Power Source Management
- Up to 1A Charging Current
- Integrated Power MOSFET
- USB Current Compliance
- 25 μ A Quiescent Current in Discharge Mode
- Taper Current Termination

- **Protection features:**
 - USB Reverse Current Blocking
 - Unsafe Battery Temp Lockout
 - Internal IC Temperature Limiter
 - USB Current Limiter

APPLICATIONS

- Navigation Devices
- Portable USB Devices
- Multi-Media Player
- PDA Phones
- Digital Cameras

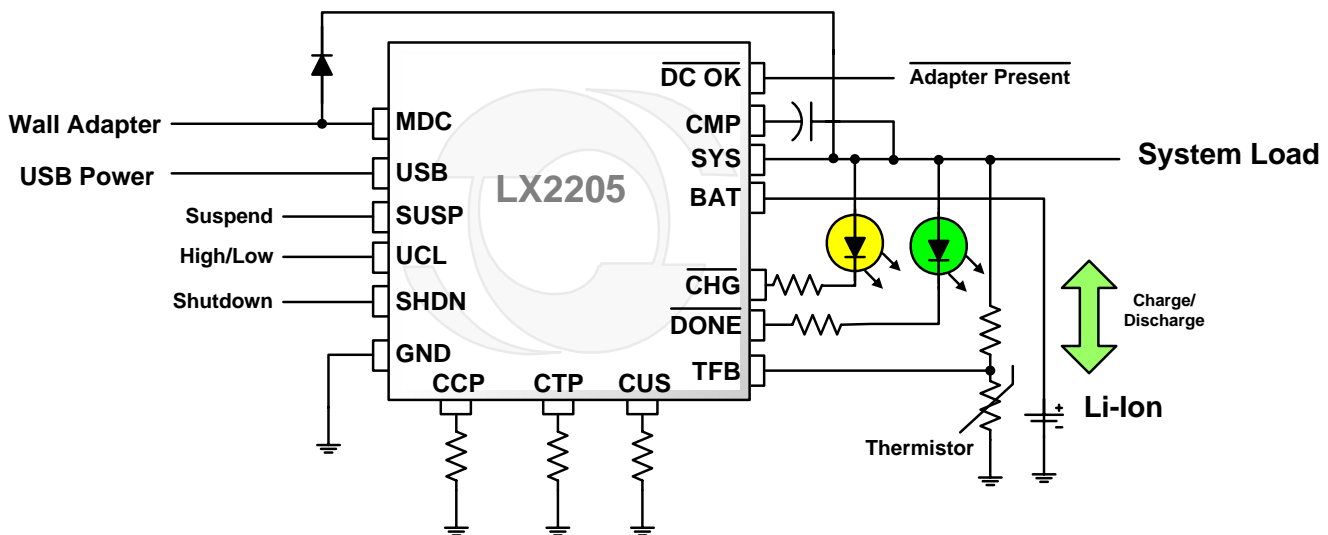
PRODUCT HIGHLIGHT

PACKAGE ORDER INFO

T_A (°C)	LQ Plastic MLP 4 x 4mm 16 pin
	RoHS Compliant / Pb-free
-40 to 85	LX2205ILQ

Note: Available in Tape & Reel. Append the letters "TR" to the part number. (i.e. LX2205ILQ-TR)

ABSOLUTE MAXIMUM RATINGS

Supply Voltages (MDC, SYS, USB)	-0.3V to 7V
Battery Voltage (BAT)	-0.3V to 6V
All Other Pins	-0.3V to V _{SUPPLY}
USB Current	600mA
BAT Discharge Current	1.6A
Operating Ambient Temperature Range (T _A)	-45°C to 125°C
Maximum Operating Junction Temperature (T _J)	150°C
Storage Temperature Range	-65°C to 150°C
Lead Temperature (Soldering 10 seconds).....	300°C
Package Peak Temp. for Solder Reflow (40 seconds maximum exposure) ...	260°C (+0 -5)

Note: Exceeding these ratings could cause damage to the device. All voltages are with respect to ground. Currents are positive into, negative out of specified terminal.

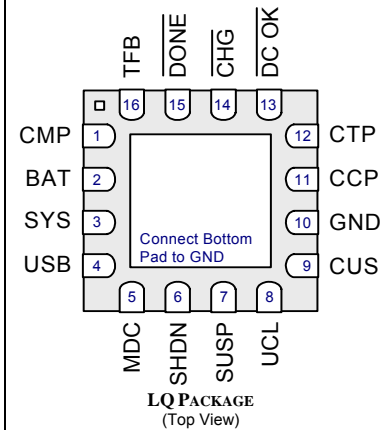
PACKAGE PIN OUT

RoHS / Pb-free 100% Matte Tin Pin Finish

THERMAL DATA
LQ Plastic 4 x 4mm 16-Pin
THERMAL RESISTANCE-JUNCTION TO AMBIENT, θ_{JA}
28°C/W*

Junction Temperature Calculation: $T_J = T_A + (P_D \times \theta_{JA})$.

*The θ_{JA} numbers are guidelines for the thermal performance of the device/pc-board system. All of the above assume no ambient airflow. See layout guidelines section for important details.

FUNCTIONAL PIN DESCRIPTION

Name	Pin	Description
BAT	2	Battery Connection - This pin is wired to the positive terminal of a single cell lithium ion/polymer battery.
CCP	11	Charge Current Programming Pin - A resistor (R _{CCP}) is connected between this pin and GND. The constant charging current is determined by the following relationship: $R_{CCP} = 50.648 \times I_{CCL}^{-1.0855}$ with R _{CCP} in kΩ and I _{CCP} in amps.
CHG	14	Charge Indicator - This pin is a logic low level when the battery is being charged, provided V _{SYS} is ≥ 4.4V. It is capable of driving the series combination of an LED and resistor that is powered from the SYS pin.
CMP	1	Compensation – Connect a 0.1μF capacitor from CMP to SYS.
CTP	12	Charge Termination Programming Pin – A resistor (R _{CTP}) is connected between this pin and GND. The charge termination taper current is determined by the following relationship: $R_{CTP} = 0.7354 \times I_{TERM}^{-1.0876}$ with R _{CTP} in kΩ and I _{TERM} in amps.
CUS	9	USB Current Limit Programming Pin – A resistor (R _{CUS}) is connected between this pin and GND. The high level USB charge current is determined by the following relationship: $I_{USB} = 1050 / R_{CUS}$.
DC OK	13	Main DC Present – A low level on this logic output indicates that the Main DC power source (typically the wall adapter) is applied.
DONE	15	Done Indicator - This pin is a logic low level when the battery charge cycle is complete. It is capable of driving the series combination of an LED and resistor that is powered from the SYS pin.
GND	10	Common Ground – Used as chip ground and as a reference for the battery return.

FUNCTIONAL PIN DESCRIPTION (CONTINUED)

Name	Pin	Description
MDC	5	Main DC Input – This input is a voltage monitoring input (and not a high current input). Its purpose is to determine the presence of the main DC input to provide lockout for the USB power input.
SHDN	6	Shutdown – Pulling this pin high will disable the entire device including the battery discharge path and place the device in a low power sleep mode. This pin has an internal pull-down.
SUSP	7	Suspend (USB) – Pulling this pin high will prevent current from being drawn from the USB input pin. The rest of the chip functions are unaffected. This pin has an internal pull-down.
SYS	3	System Power Node – This pin provides power to user system. SYS voltage provided will range from the battery voltage to the wall adapter and/or USB voltage.
TFB	16	Temperature Feedback – Charging is suspended when the TFB pin falls below 29% (typ) of V_{SYS} or rises above 74% (typ) of V_{SYS} . \overline{CHG} and \overline{DONE} pins remain in their prior state during a TFB event. Connecting the TFB pin to GND disables the TFB function.
USB	4	USB Power Input – USB compliant input.
UCL	8	USB Current Limit – A high logic level will select the high USB current level determined by the programming of the CUS pin. A low logic level will select a level that is 20% of the high USB current level. This pin has an internal pull-down.

ELECTRICAL CHARACTERISTICS

Unless otherwise specified, the following specifications apply over the operating temperature $-40^{\circ}\text{C} \leq T_A \leq 85^{\circ}\text{C}$ and the following test conditions: $V_{\text{MDC}} = V_{\text{USB}} = 5\text{V}$, $V_{\text{SYS}} = \text{Open}$, $V_{\text{SUSP}} = V_{\text{SHDN}} = \text{Low}$, $V_{\text{UCL}} = \text{High}$, $V_{\text{BAT}} = 3.9\text{V}$, $R_{\text{CCP}} = 49.9\text{k}$, $R_{\text{CUS}} = 2.26\text{k}$, $R_{\text{CTP}} = 20\text{k}$

Parameter	Symbol	Test Conditions	LX2205			Units
			Min	Typ	Max	
MAIN CIRCUITRY						
Input Voltage	V_{SUPPLY}	USB or SYS	4.35		6	V
Under Voltage Charging Lockout	$V_{\text{SYS(UVLO)}}$	Rising input; $V_{\text{BAT}} = 3.2\text{V}$	3.55	3.7	3.95	V
SYS UVLO Hysteresis		Guaranteed by design		140		mV
USB UVLO	$V_{\text{USB(UVLO)}}$	Rising input; $V_{\text{BAT}} = 3.2\text{V}$	4.25	4.30	4.34	V
SYS Input Supply Current	I_{SYS}	$V_{\text{BAT}} = V_{\text{CVL}}$; (battery charged), $V_{\text{SYS}} = 5.0\text{V}$		1.5	2.5	mA
		SHDN = High (Shutdown Mode), $V_{\text{SYS}} = 5.0\text{V}$		25		μA
USB Input Supply Current	I_{USB}	$V_{\text{BAT}} = V_{\text{CVL}}$; (battery charged), , $V_{\text{MDC}} = 0\text{V}$		2		mA
		SUSP = High (Suspend Mode), , $V_{\text{MDC}} = 0\text{V}$			25	μA
		SHDN = High (Shutdown Mode), , $V_{\text{MDC}} = 0\text{V}$			25	μA
		$V_{\text{MDC}} = 0\text{V}$, $V_{\text{USB}} = 0\text{V}$		-1.5	-6	μA
Battery Drain Current	I_{BAT}	$V_{\text{BAT}} = V_{\text{CVL}}$; (battery charged)		0.5	10	μA
		$V_{\text{MDC}}=0\text{V}$; SUSP = High (Suspend Mode)		25	50	μA
		SHDN = High (Shutdown Mode)		0.5	10	μA
		$V_{\text{USB}} = 0\text{V}$; $V_{\text{MDC}} = 0\text{V}$; Discharge with no load		25	50	μA
BATTERY CHARGER						
Constant Voltage Charge Voltage	V_{CVL}		4.16	4.2	4.24	V
CTP Bias Voltage	V_{CTP}	$I_{\text{BAT}} > 100\text{mA}$		1.30		V
CCP Bias Voltage	V_{CCP}			1.25		V
Max Battery Charge Current	I_{CCL}	$V_{\text{SYS}} = 5.0\text{V}$	0.85	0.98	1.10	A
		$V_{\text{MDC}}=0\text{V}$		465		mA
		$V_{\text{MDC}}=0\text{V}$; $I_{\text{SYS}} = 200\text{mA}$ (out of pin)		261		mA
		$V_{\text{MDC}}=0\text{V}$; UCL = Low		92		mA
Conditioning Current	I_{COND}	$V_{\text{BAT}} = 2.5\text{V}$, as a % of I_{CCL}	2.5	5	7.5	%
Conditioning Current Threshold Voltage	V_{CCT}		2.55	2.7	2.9	V
Charge Termination Current	I_{BAT}		40	50	60	mA
Top Off Charge Droop Threshold	V_{DRP}	Expressed as a % of V_{CVL}	96	97	98	%

ELECTRICAL CHARACTERISTICS (CONTINUED)

Unless otherwise specified, the following specifications apply over the operating temperature $-40^{\circ}\text{C} \leq T_A \leq 85^{\circ}\text{C}$ and the following test conditions: $V_{\text{MDC}} = V_{\text{USB}} = 5\text{V}$, $V_{\text{SYS}} = \text{Open}$, $V_{\text{SUSP}} = V_{\text{SHDN}} = \text{Low}$, $V_{\text{UCL}} = \text{High}$, $V_{\text{BAT}} = 3.9\text{V}$, $R_{\text{CCP}} = 49.9\text{k}$, $R_{\text{CUS}} = 2.26\text{k}$, $R_{\text{CTP}} = 20\text{k}$

Parameter	Symbol	Test Conditions	LX2205			Units
			Min	Typ	Max	
USB CURRENT LIMIT						
USB Low Current Limit	I_{USB}	$V_{\text{MDC}} = 0\text{V}$, $\text{UCL} = \text{Low}$	85	93	100	mA
USB High Current Limit	I_{USB}	$V_{\text{MDC}} = 0\text{V}$	425	463	500	mA
Reverse Leakage Current	I_{LEAK}	$V_{\text{USB}} = 0\text{V}$		2	10	μA
CUS Bias Voltage	V_{CUS}			2.5		V
LOGIC						
$\overline{\text{CHG}}$, $\overline{\text{DONE}}$ Logic High Output	V_{OH}	$V_{\text{SYS}} = 5.0\text{V}$, $I_{\text{OH}} = -25\mu\text{A}$	4.0	4.5		V
$\overline{\text{CHG}}$, $\overline{\text{DONE}}$ Logic Low Output	V_{OL}	$V_{\text{SYS}} = 5.0\text{V}$, $I_{\text{OL}} = 5\text{mA}$			0.4	V
Input Logic : UCL, SUSP, SHDN	$V_{\text{LOG(IN)}}$	Logic Hi,	1.2			V
		Logic Lo			0.4	
Input Logic Current : UCL, SUSP, SHDN	$I_{\text{LOG(IN)}}$	Logic Hi, $V_{\text{LOG}} = 2\text{V}$	0	2	4	μA
		Logic Lo, $V_{\text{LOG}} = 0\text{V}$	-2	0	2	
Output Logic : $\overline{\text{DC OK}}$	$V_{\text{LOG(OUT)}}$	Logic Hi, 10K to 3.3V	3.2			V
		Logic Lo, $I_{\text{LOG}} = 100\mu\text{A}$			0.4	
THERMAL DIE PROTECTION						
Battery Charger Thermal Limiter	T_{CTL}			140		$^{\circ}\text{C}$
BI-DIRECTIONAL PASS ELEMENT CONTROL						
Discharge Switch On Resistance	$R_{\text{DS(ON)}}$	$I_{\text{BAT}} = -1\text{A}$		275		m Ω
Charging Threshold	V_{CHG}	$V_{\text{SYS}} - V_{\text{BAT}}$		40		mV
Discharging Threshold	V_{DCH}	$V_{\text{BAT}} - V_{\text{SYS}}$		40		mV
Pass Element Switch Mode Delay	t_{sw}	Charge-To-Discharge or Discharge-To-Charge		2.5		μs
Charging headroom		$V_{\text{SYS}} - V_{\text{BAT}}$, $I_{\text{BAT}} = 5\text{mA}$		80		mV
Discharging headroom		$V_{\text{BAT}} - V_{\text{SYS}}$, $I_{\text{BAT}} = -20\text{mA}$		80		mV
MDC INPUT						
$\overline{\text{DC OK}}$ Voltage Threshold	V_{MDC}	Rising	4.0	4.15	4.3	V
Hysteresis	$V_{\text{MDC(HYS)}}$			35		mV
MDC Input current	I_{MDC}			15	35	μA
BATTERY TEMPERATURE MONITOR						
Cold Temp Fault Threshold	$V_{\text{TFB(COLD)}}$	Rising Threshold ; as % of V_{SYS}	73	75	77	%
		Falling Threshold; as % of V_{SYS}	71	73	75	%
Hot Temp Fault Threshold	$V_{\text{TFB(HOT)}}$	Falling Threshold; as % of V_{SYS}	27	28.5	30	%
		Rising Threshold; as % of V_{SYS}	28	29.5	31	%
TFB Disable Voltage Threshold	$V_{\text{TFB(DIS)}}$		70	100	150	mV



CHARGER CONTROL FLOW DIAGRAM

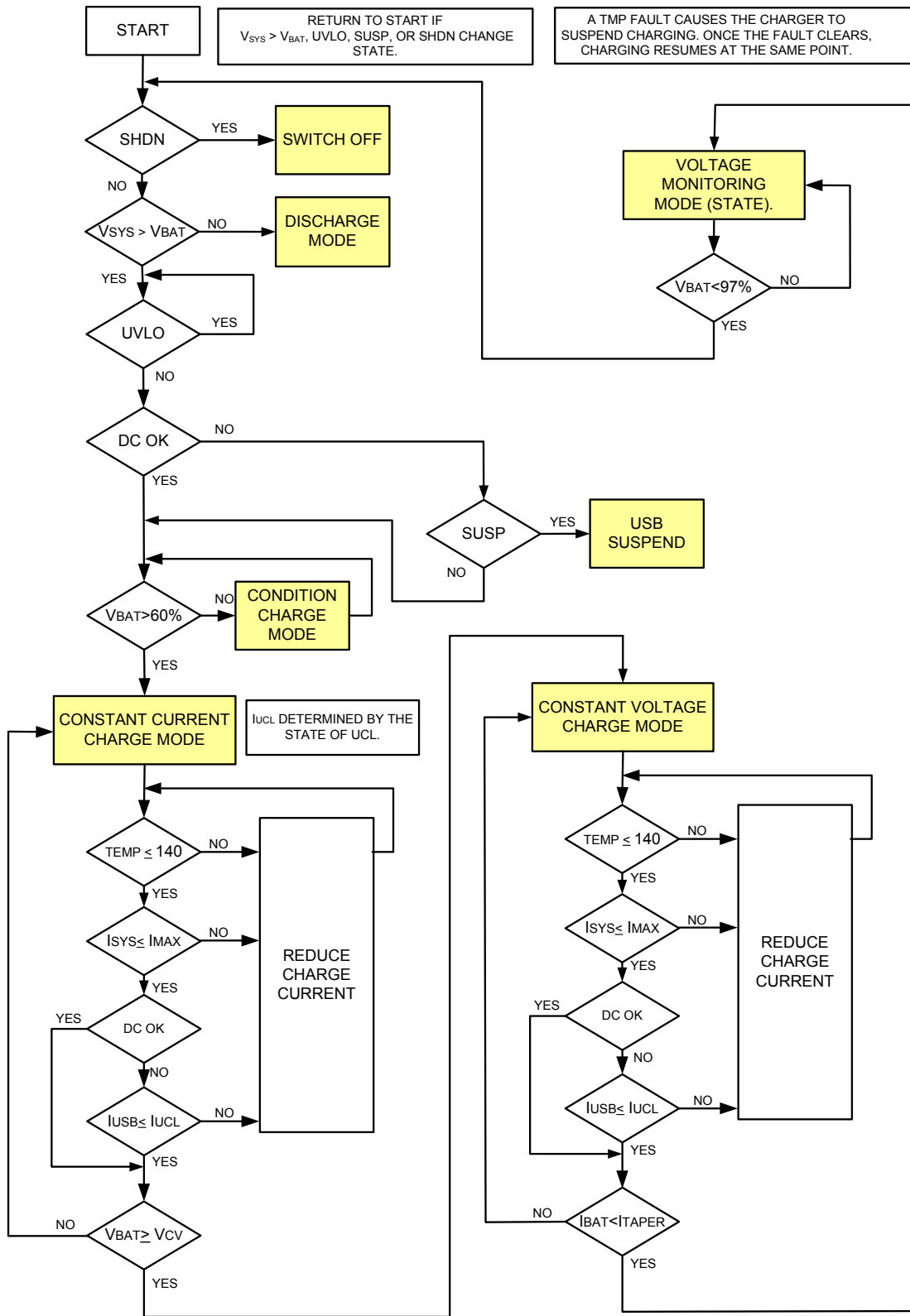



SIMPLIFIED BLOCK DIAGRAM

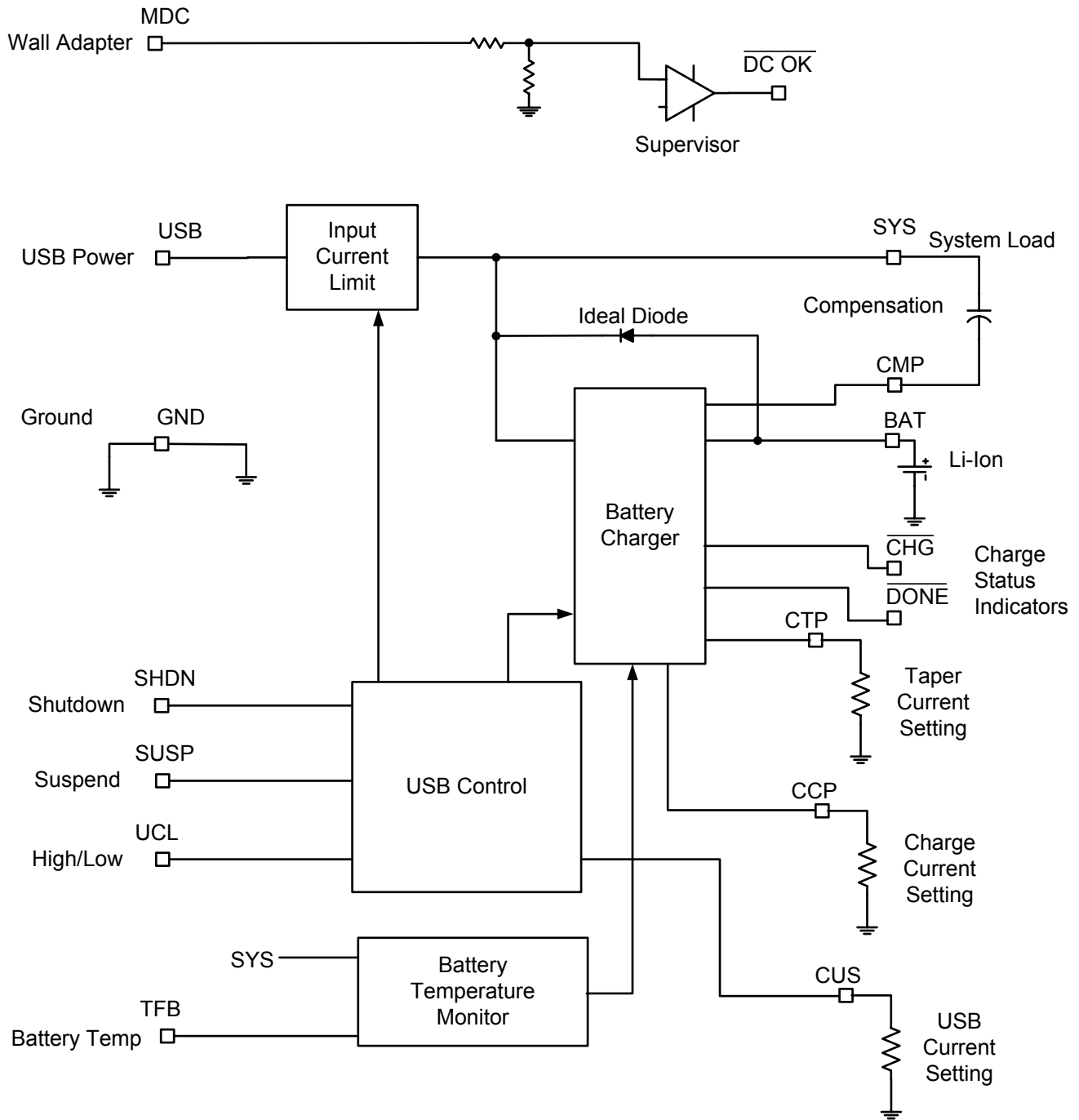



APPLICATION CIRCUITS

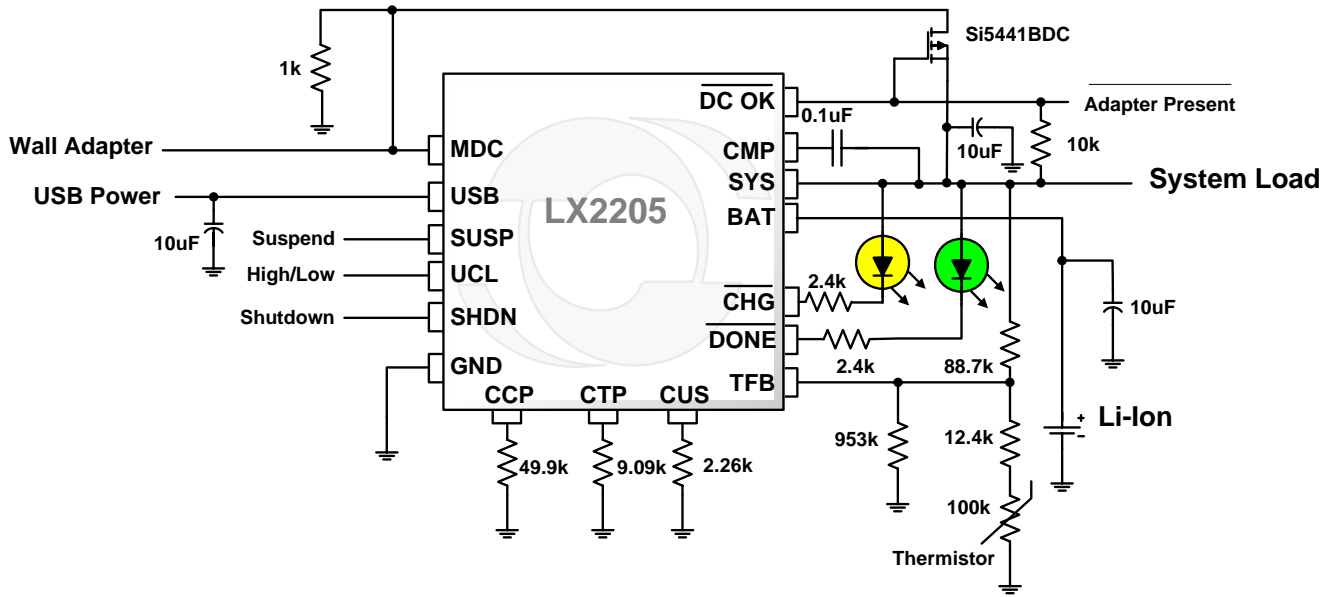

Figure 3 – AC Adapter and USB Supply (Charge and Discharge Modes) with 1A charging and 100mA termination current. In this application, the wall adapter voltage is not well regulated and can dip to less than 4.7V. For this case, a reverse blocking MOSFET is used instead of the reverse blocking diode, shown in the Product Highlight. This extends the operating range of the LX2205 because the drop across the MOSFET is minimal. It also increases efficiency by eliminating the power loss of the schottky diode.

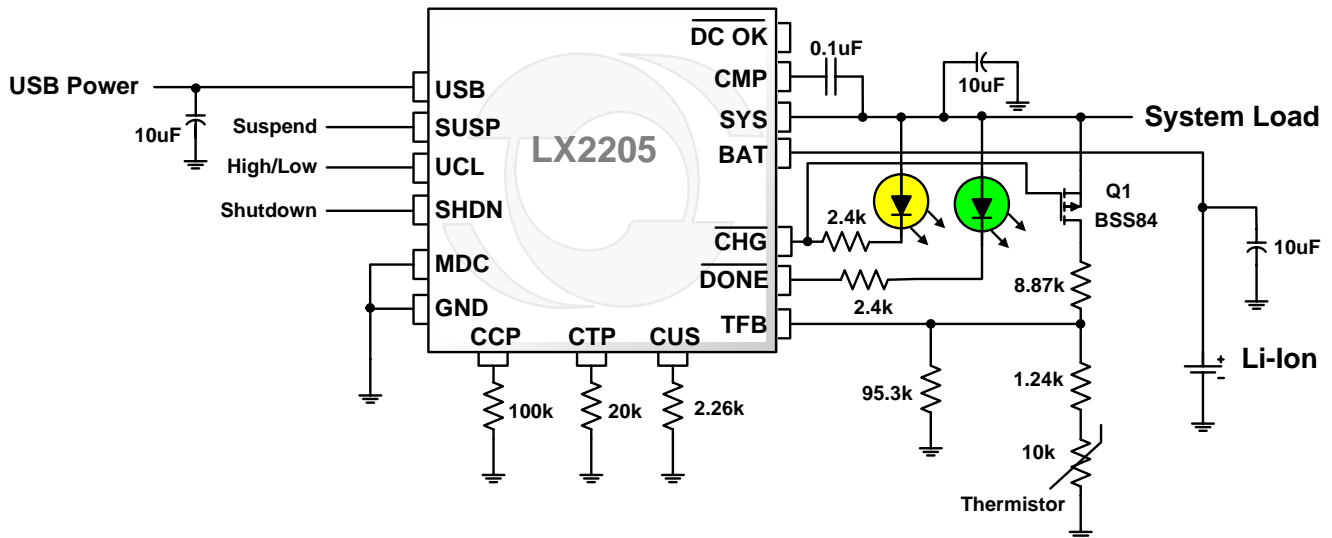
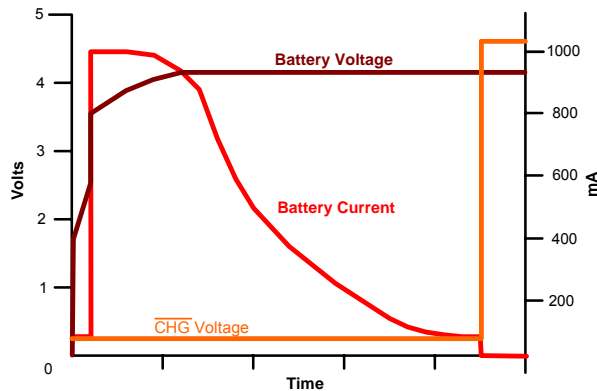

Figure 4 – This application uses only a USB input with 500mA and 100mA maximum current limit levels and a 50mA termination current level. MOSFET Q1 turns off the TFB resistor string when not in charge mode to prevent battery drain; this is particularly helpful when using a small thermistor resistance value in the battery pack.

THEORY OF OPERATION
BATTERY CHARGER GENERAL DESCRIPTION

The LX2205 is designed to charge a single cell Lithium Ion or Lithium Polymer battery using two steps: a constant current step followed by a constant voltage step. The basic charger function uses the SYS pin as an input and BAT pin as the output. The LX2205 charger has a programmable maximum current (programmable by the resistor value between the CCP pin and GND) which is the maximum charging current during the Constant Current Mode of the charging profile. The charger will terminate constant voltage charging once the current drops below the taper current setting (programmable by the resistor value between CTP pin and GND).

Two step charger profile:

CONDITIONING CURRENT CHARGE MODE

A conditioning current is applied to a battery that is deeply discharged and has a terminal voltage less than 60% of the constant voltage level. The conditioning current is 5% of the CCP programmable constant current level. Once the battery terminal voltage exceeds the 60% level, the full constant current level is applied (unless charging current is limited by one of the other charger control loops).

CHARGE TERMINATION MODE

To increase system battery life and avoid float charging, the LX2205 disconnects the charger once the battery has been fully charged. The charge termination state occurs at the end of constant voltage mode. The charge status indicators change state when charging is completed.

STATES	CHG	DONE
Charge in process	ON	OFF
Charge completed	OFF	ON
Input power removed	OFF	OFF

Using the taper current to terminate the charge cycle is particularly advantageous in an isolated battery topology such as the LX2205, because when an external power source is applied to the appliance with the appliance turned on, the power to the appliance and the power to the battery take separate paths. This separate path allows the battery charge current to be monitored accurately. Compared with charger controllers that rely on a fixed timeout period terminating by taper current allow for the shortest possible battery charge time.

TOP OFF CHARGE MODE

Once the charger has completed a charge cycle, if power remains applied, the LX2205 enters a voltage monitoring mode. In this mode the LX2205 monitors the battery terminal voltage and applies a top off charge if the battery voltage drops by more than 3% of V_{CVL} . This feature is especially important for charging systems in equipment where usage is infrequent.

USB CHARGE MODE AND CURRENT LIMIT

The LX2205 is fully compliant with, and supports, the USB specifications – the Low Power Peripheral (100mA) and High Power Peripheral (500mA). The UCL logic input selects the USB charge current level. The LX2205 senses the current flowing from the USB terminal to the SYS terminal. The LX2205 will first try to reduce the combined USB load by scaling back the battery charging current. Once the charger has scaled back the charge current to zero, if the load demands more current than the USB bus can supply the V_{SYS} voltage will drop down to the battery voltage level and the battery will supply the additional current demand. This is illustrated in the following two charts.

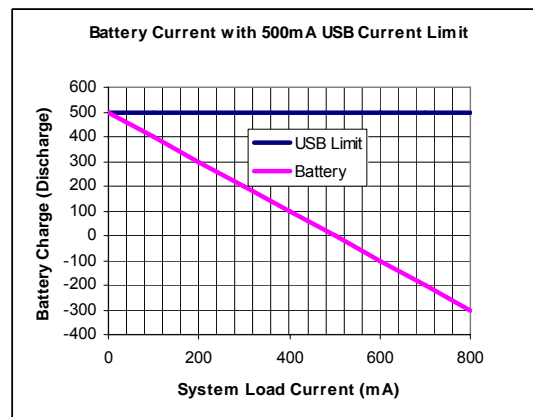

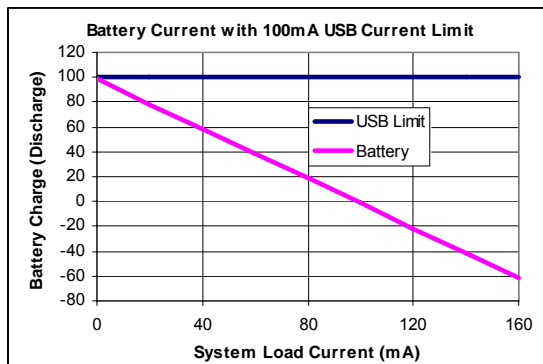
THEORY OF OPERATION

REDUCED USB CHARGE TIME

The isolated battery topology reduces charge time from the USB port when the appliance is turned on while also charging. Because the system power rail can be a higher voltage than the battery voltage, the system will require less power from the USB source which leaves more power available to charge the battery quickly. For example, if the system draws 1W, and the USB input is 5V, the system draws $1W/5V = 200mA$ from the USB source; this leaves 300mA to charge the battery. In a topology where the load connects directly to the battery (as is done with conventional non-isolated linear chargers), if the average battery voltage is 3.7V, the system will draw $1W/3.7V = 270mA$ from the USB source, this leaves only 230mA to charge the battery. In this case the LX2205 will charge the battery 30% faster.

USB SUSPEND

When the SUSP pin is pulled high, less than $25\mu A$ is pulled from the USB port. The rest of the LX2205, however, continues to function normally. If an adapter is applied, the effect of SUSP is negligible. If the system is running off both USB and the battery and SUSP is logic high, the system load will be transferred 100% to the battery.

SHDN

When SHDN is logic high, the LX2205 is placed in a total shutdown mode; no current will flow between SYS, USB and BAT. Quiescent current is $25\mu A$ during shutdown. \overline{CHG} and \overline{DONE} are high impedance (off) in SHDN mode.

UCL

The UCL pin is used to select the current limit level for the USB input. When the UCL pin is a logic high the maximum current level as determined by the CUS resistor is selected; when the UCL pin is a logic low, the current limit is set to 20% of the maximum level.

POWER OR-ING (SYS TO BAT AND BAT TO SYS)

When the power is removed from both MDC and USB, the battery current flows from BAT to SYS and thus provides power to the load without the need for any external switches or monitoring circuits. There is a circuit equivalent of an ideal diode (patent-pending bi-directional MOSFET) in the LX2205 between the BAT pin and SYS pin. This ideal diode appears as a low impedance to high forward current and presents a high impedance to low discharge currents or potentially reverse charge currents. For small forward currents, the ideal diode regulates a small forward voltage. This small voltage allows the power sense circuitry to determine whether an input power source is present even if the current through the ideal diode is less than 1mA. This feature makes it virtually impossible to charge the battery (unregulated) in reverse through the ideal diode and also enables the battery to assist a current limited input power source without chattering even if only a few mA of battery current are required.

THEORY OF OPERATION / APPLICATION NOTE
MDC, USB OR-ING, UVLO AND DC OK

The power path from the USB input to the SYS pin consists of a current limiter and a bidirectional switch (capable of blocking current in either direction). The USB input is switched off when at least one of the following conditions exists:

1. $V_{USB} < V_{USB_{UVLO}}$
2. USB Suspend pin is asserted.
3. $V_{MDC} > V_{USB}$
4. $V_{MDC} > \overline{V_{DCOK_THRESHOLD}}$

The MDC input is a monitoring input only, it is not a high current input. When the voltage at SYS exceeds the UVLO level, (typically 3.7V), the charger portion of the circuit is activated. The \overline{DCOK} output is pulled low when both of the following conditions are true:

1. $V_{MDC} > \overline{V_{DCOK_THRESHOLD}}$
2. $V_{SYS} > V_{BAT}$

Therefore when using a current limited wall adapter it is possible to charge the battery and not assert the \overline{DCOK} output.

PROTECTION FEATURES

Conditioning Current Mode – If the battery terminal voltage is less than 2.7V, the battery charger will reduce the charge current to 5% of full scale. This also protects the appliance from overheating by trying to drive the full charging current into a short circuited battery.

Under Voltage Lockout – The charger remains inactive until the under voltage lockout threshold is exceeded at the SYS pin.

Thermal Control Loop – The power dissipation of the charger is limited by reducing the charge current with a control loop to prevent the die temperature from exceeded approximately 140°C.

Reverse Current Blocking – Current will not flow out of the USB pin.

Shutdown Mode – If the SHDN pin is logic high, the charger enters a shutdown mode to prevent draining the battery.

Battery Temperature Lockout – If an unsafe temperature is sensed by the TFB input window comparator, battery charging is suspended.

LAYOUT GUIDELINES

- It is important when laying out the LX2205 to place 10µF ceramic capacitors as close to the SYS, USB and VBAT IC terminals as possible to filter switching transients.
- It is important to provide a low thermal impedance path from the thermal pad on the bottom of the LX2205 package to the ground plane of the circuit board to maximize heat dissipation. Generally this is accomplished by the use of multiple thermal vias.
- The compensation capacitor should be placed close to the CMP pin and connected with a short trace.

CHARGE CURRENT PROGRAMMING

The CCP, CTP, and CUS programming pins are used to program the constant charge current, termination current, and USB current, respectively. These pins utilize regulated output voltages that produce a program current across an external resistor to GND.

The following tables are guidelines for selecting the proper resistor values:

Constant Charge Current (in mA)	R _{CCP}
50	1270k
100	604k
200	294k
300	187k
400	137k
500	107k
600	88.7k
700	75.0k
800	63.4k
900	56.2k
1000	49.9k*

* R_{CCP} minimum value

Termination Current (in mA)	R _{CTP}
5	237k
10	105k
20	51.1k
40	24.9k
60	15.8k
80	11.8k
100	9.09k
120	7.50k
140	6.34k
160	5.49k
180	4.75k
200	4.22k

APPLICATION NOTE
BATTERY TEMPERATURE MONITOR

The LX2205 has an input to monitor the battery temperature during battery charging. The SYS voltage must be used to bias this circuitry. During the occurrence of a TMP fault, the charge cycle is suspended; however the status indicators state remains unchanged.

A typical Lithium Ion battery should only be charged within a temperature range of 0°C to 60°C. For this calculation example, a Vishay NTHS0402N01N1003J thermistor was used. This thermistor has the value of 327kΩ at 0°C, 100kΩ at 25°C and 24.9kΩ at 60°C. The thermistor must be biased with a Thevenin voltage source and series resistance to achieve the proper TMP thresholds. A fixed value resistor is added in series with the thermistor to prevent it from becoming too low impedance at high temperatures and causing the TMP input to default to off.

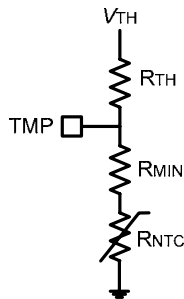

Using a value of R_{MIN} that is $\frac{1}{2}$ the thermistor high temperature trip resistance value works well; therefore, for this example, set the value of R_{MIN} to:

$$12.4k = R_{MIN} = \frac{R_{T=60^{\circ}C}}{2}$$

This has the effect of adding a fixed 12.4k to the thermistor resistance values so it becomes 339kΩ at 0°C, 112kΩ at 25°C and 37.3kΩ at 60°C.

The equations for R_{TH} and V_{TH} are, using Cold Temperature Fault Threshold average of 74% and the Hot Temperature Fault Threshold average of 29% of V_{SYS} :

$$\frac{V_{TH}}{V_{SYS}} = \frac{0.29 \times 0.74 \times (R_{T=0^{\circ}C} - R_{T=60^{\circ}C})}{(0.29 \times R_{T=0^{\circ}C}) - (0.74 \times R_{T=60^{\circ}C})}$$

$$= K = 0.916$$

$$R_{TH} = \left(\frac{K}{0.74} - 1 \right) \times R_{T=0^{\circ}C} = 80.6k$$

To finish the design it is necessary to create the Thevenin Voltage and resistance using a voltage divider from the SYS pin.

The values of R_1 and R_2 can be calculated as:

$$R_1 = \frac{R_{TH}}{K} = 88k$$

$$R_2 = \frac{R_1 \times R_{TH}}{R_1 - R_{TH}} = 958k$$

Actual standard 1% resistor values are: 953k and 88.7k. The final circuit for this example is:

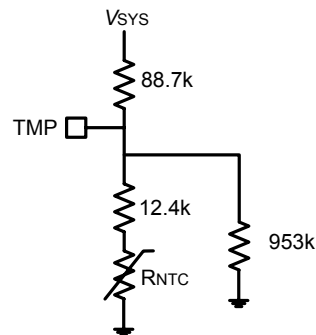

The TMP voltages with this circuit are:

TEMP (°C)	RNTC	VTMP (% VSYS)
-20	971k	85%
0	327k	74%
25	100k	53%
60	24.9k	29%
80	12.6k	22%



TYPICAL CHARGING CURRENT VS BATTERY VOLTAGE

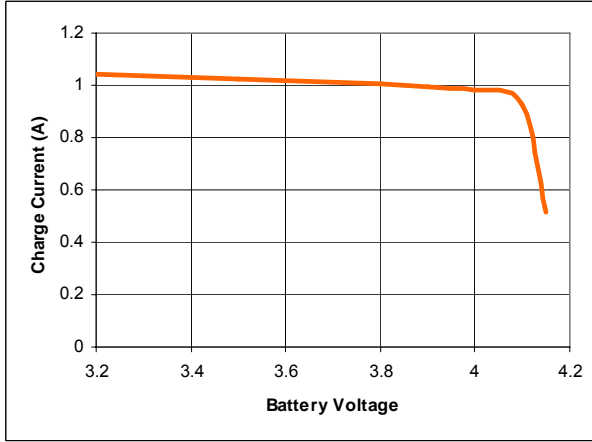

TYPICAL CHARGING CURRENT VS V_{sys}

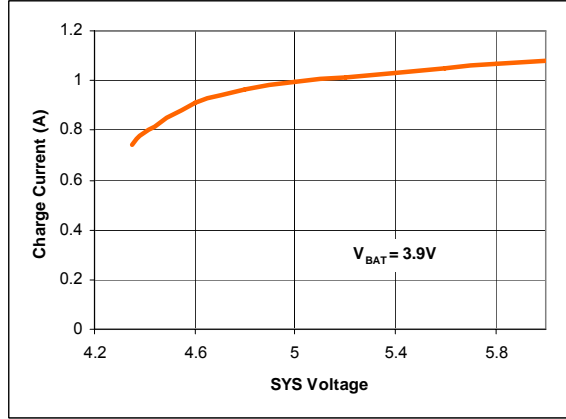

TYPICAL USB CURRENT LIMIT VS USB VOLTAGE

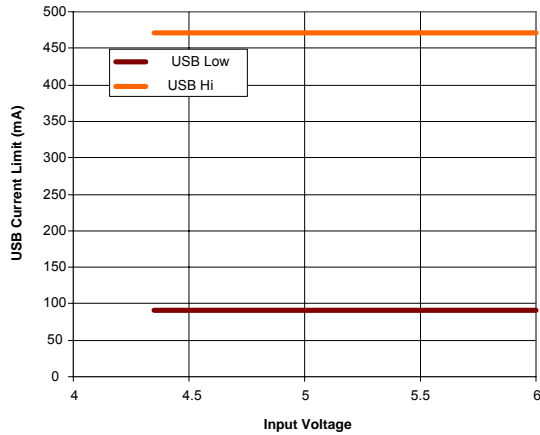

TYPICAL V_{CVL} DISTRIBUTION

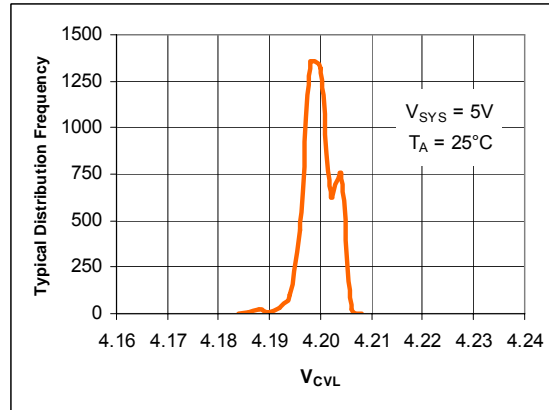

CHARGE TO DISCHARGE SWITCHOVER

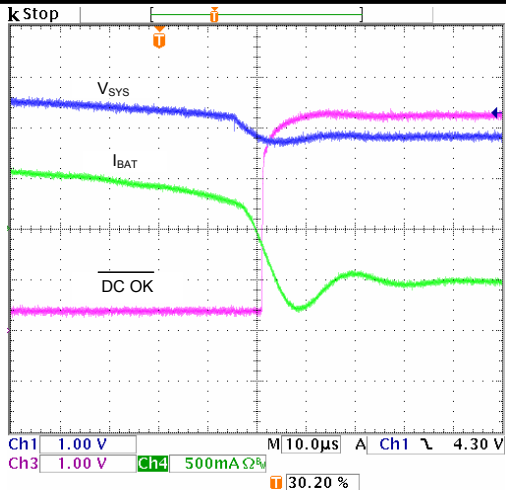

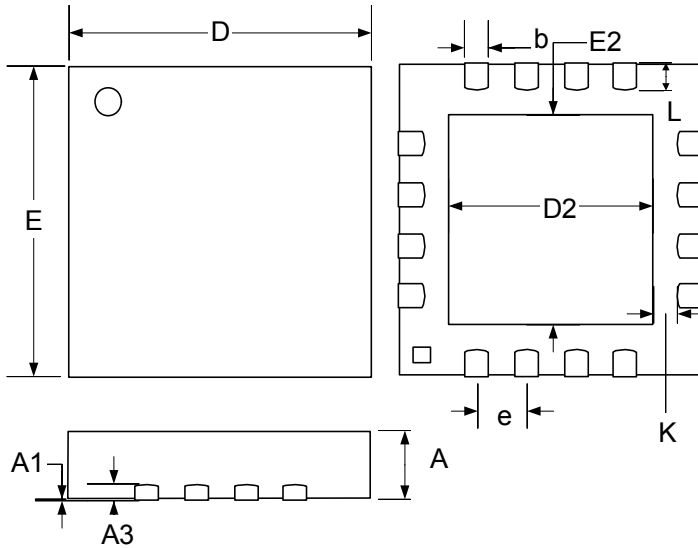

PACKAGE DIMENSIONS

LQ**16-Pin MLPQ Plastic (4x4mm EP / 114x114Cu Exposed Pad)**

Dim	MILLIMETERS		INCHES	
	MIN	MAX	MIN	MAX
A	0.80	1.00	0.031	0.039
A1	0	0.05	0	0.002
A3	0.18	0.30	0.007	0.012
b	0.23	0.38	0.009	0.015
D	4.00 BSC		0.157 BSC	
E	4.00 BSC		0.157 BSC	
e	0.65 BSC		0.026 BSC	
D2	2.55	2.80	0.100	0.110
E2	2.55	2.80	0.100	0.110
K	0.20	-	0.008	-
L	0.30	0.50	0.012	0.020

Note:

- Dimensions do not include mold flash or protrusions; these shall not exceed 0.155mm(.006") on any side. Lead dimension shall not include solder coverage.

PRODUCTION DATA – Information contained in this document is proprietary to Microsemi and is current as of publication date. This document may not be modified in any way without the express written consent of Microsemi. Product processing does not necessarily include testing of all parameters. Microsemi reserves the right to change the configuration and performance of the product and to discontinue product at any time.