



# LXOM OSCILLATOR

10 kHz to 2.1 MHz\*

Low Power Crystal Oscillator

## DESCRIPTION

Statek's LXOM oscillator consists of a CMOS-compatible hybrid circuit, packaged in a hermetically-sealed, half-size metal DIP. Permanent, precision tuning of the oscillator is accomplished by laser trimming the crystal after it has been hermetically sealed in a ceramic package and connected to the oscillator circuit. This method of fine tuning allows for very tight calibration tolerance and eliminates the need for a trimming capacitor, a major source of long-term frequency drift. The specifications and characteristics of the LXOM vary with frequency. The characteristics of the 32.768 kHz model are presented in this data sheet.

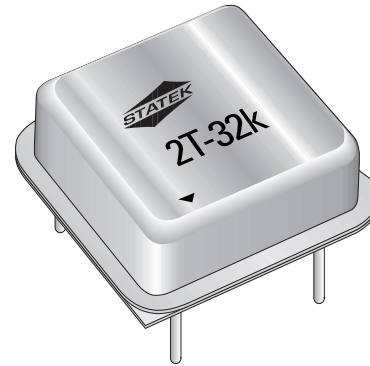

\*Consult factory for other frequencies.

## FEATURES

- Low power consumption
- Low aging
- CMOS compatible
- Double hermetically sealed package
- Full military testing available
- 3 Volt operation available

## APPLICATIONS

Industrial, Computer & Communications

- General purpose clock oscillator
- Data Logger
- Remote sensor
- Liquid level sensing
- Medical test and diagnostics

Military

- Portable field communication
- Military high speed modem
- Flight recorder

## PACKAGE DIMENSIONS

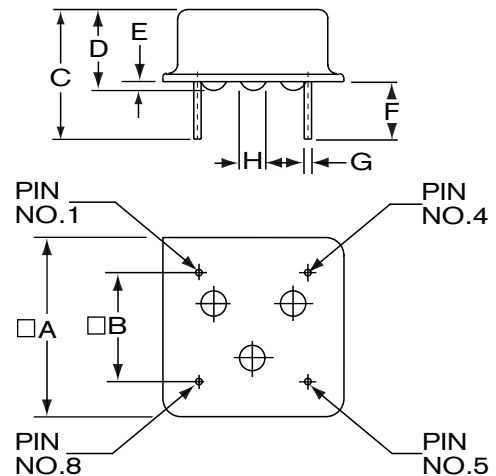

DIM	inches	mm
A	0.505 MAX.	12.83 MAX.
B	0.300 ±0.005	7.62 ±0.13
C	0.430 TYP.	10.92 TYP.
D	0.225 MAX.	5.72 MAX.
E	0.025 TYP.	0.64 TYP.
F	0.150 MIN.	3.81 MIN.
G	0.018 ±0.002	0.46 ±0.05
H	0.063 TYP.	1.60 TYP.

\* Position of bumps for reference only



## SPECIFICATIONS: LXOM 32.768 kHz

Specifications are typical at 25°C unless otherwise noted.  
Specifications are subject to change without notice.

Supply Voltage ( $V_{DD}$ )	5V $\pm$ 10% (3.3V available)
Calibration Tolerance <sup>1</sup>	$\pm$ 10 ppm (0.001%) $\pm$ 25 ppm (0.0025%) $\pm$ 100 ppm (0.01%)
Frequency Stability <sup>2</sup>	
0°C to +50°C	$\pm$ 25 ppm Typ. (0.0025%) $\pm$ 40 ppm MAX. (0.004%)
-10°C to +70°C	$\pm$ 70 ppm Typ. (0.007%) $\pm$ 100 ppm MAX. (0.01%)
Voltage Coefficient	$\pm$ 1 ppm/V Typ. $\pm$ 3 ppm/V MAX.
Aging	$\pm$ 1 ppm/year Typ. $\pm$ 3 ppm/year MAX.
Shock	1000 g, 1 ms, 1/2 sine $\pm$ 3 ppm MAX.
Vibration	10 g RMS, 10-2000 Hz $\pm$ 3 ppm MAX.
Frequency Change vs 10% Output Load Change	$\pm$ 1 ppm MAX.
Operating Temp. Range	-10°C to +70°C (Commercial) -40°C to +85°C (Industrial) -55°C to +125°C (Military)

1. Tighter tolerances available
2. Does not include calibration tolerance. Positive variations small compared to negative variations.

## TYPICAL CURRENT CONSUMPTION, LXOM-32.768 kHz

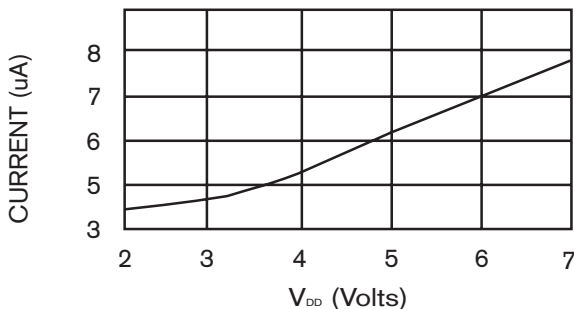

## ABSOLUTE MAXIMUM RATINGS

Supply Voltage $V_{DD}$	-0.3V to 7V
Storage Temperature	-55°C to +125°C

## ELECTRICAL CHARACTERISTICS

### LXOM-32.768 kHz

All parameters are measured at ambient temperature with a 10M $\Omega$  and 10pF load at 5V.

SYMBOL	PARAMETER	MIN.	TYP.	MAX.	UNIT
$V_{OH}$	Output Voltage Hi	4.8	4.95		V
$V_{OL}$	Output Voltage Lo		0.05	0.2	V
$t_r$	Rise Time (10%-90%)		27	50	ns
$t_f$	Fall Time (10%-90%)		29	50	ns
SYM	Duty Cycle	40	50	60	%
	Supply Current				
$I_{DD}$	$V_{DD}=5V$		6.5	12	$\mu A$
	$V_{DD}=3V$		5	10	$\mu A$

## PIN CONNECTIONS

Pin	Connection
1	INH (Tri-State) or NC
4	Ground
5	Output
8	$V_{DD}$

## PACKAGING

LXOM -Tube Pack

## OUTPUT WAVE FORM

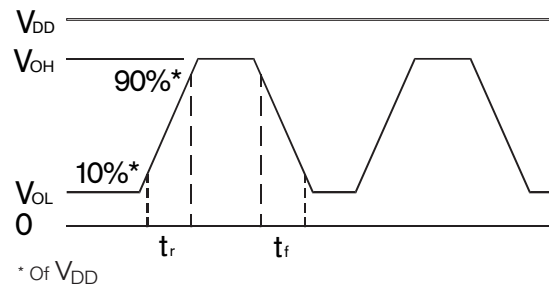

## HOW TO ORDER LXOM CRYSTAL OSCILLATORS

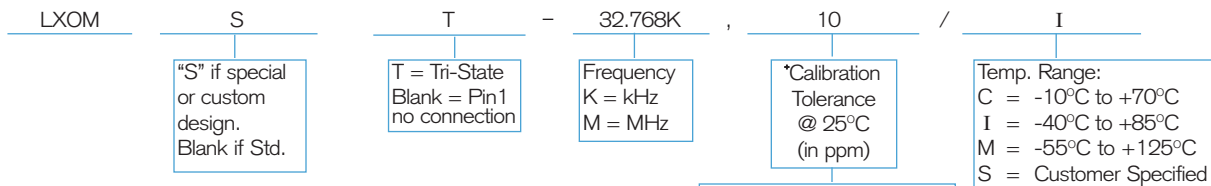

\*Other calibration fill in ppm.  
Standard Calibration Tolerances for frequencies other than 32.768 kHz:  
1) 100 ppm (0.01%)  
2) 300 ppm (0.03%)  
3) 1000 ppm (0.1%)