

#### FEATURES

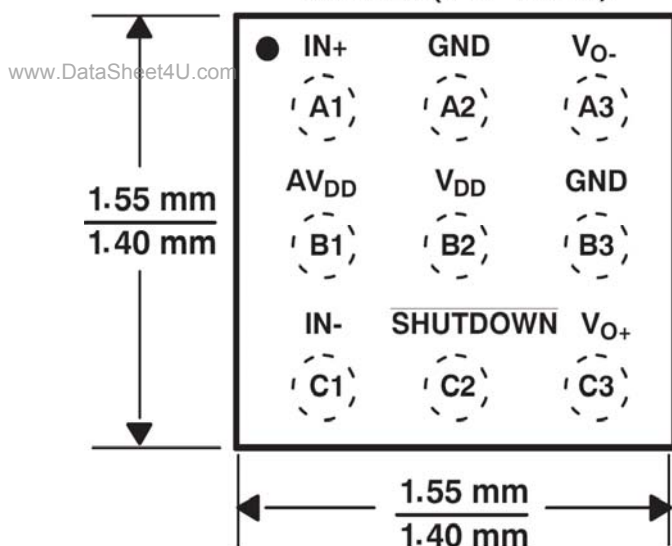
- 2.5 W Into 4Ω from 5V power supply at THD = 10% (Typ).
- 2.5V~5.5V Power supply.
- Low shutdown Current.
- Low Quiescent Current.
- Minimum external components.
- No output filter required for inductive loads.
- Output Pin Short-Circuit Protection (Short to Output Pin, Short to GND, Short to VDD)
- Low noise during turn-on and turn-off transitions.
- Lead free and green package available. (RoHS Compliant)
- Space Saving Package
  - Wafer Chip Scale Packaging (WCSP).
  - DFN Package

#### APPLICATION

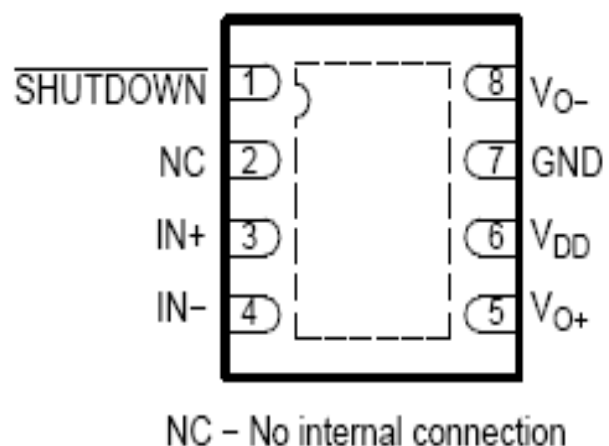
- Portable electronic devices
- Mobile Phones
- PDAs

#### PIN CONFIGURATION

##### WAFER CHIP SCALE PACKAGES LY8010 DIMENSIONS 9-BALL (TOP VIEW)



##### 8-PIN DFN PACKAGE (TOP VIEW)



#### GENERAL DESCRIPTION

The LY8010 is a high efficiency, 2.5 W mono class D audio power amplifier. It is a low noise, filterless PWM architecture eliminates the output filter, reducing external component count, system cost, and simplify design.

The LY8010 is designed to meet of mobile phones and other portable electronic devices. The LY8010 is a single 5V supply, it is capable of driving 4Ω speaker load at a continuous average output of 2.5 W with 10% THD+N. Not external heat-sink is required.

In cellular handsets, the earpiece, speaker phone, and melody ringer can each be driven by the LY8010.

Output pin short circuit ( short to output pin, short to ground and short to VDD ) protection prevent the device from damage during fault conditions.



#### PIN DESCRIPTION

SYMBOL	Pin No.		DESCRIPTION
	DFN	WCSP	
SHUTDOWN	1	C2	Shutdown the device.(when low level is active the pin)
+IN	3	A1	Positive input
-IN	4	C1	Negative input
Vo+	5	C3	Positive BTL output
AVDD	--	B1	Analog Power supply
VDD	6	B2	Power supply
GND	7	A2/B3	Ground
Vo-	8	A3	Negative BTL output

#### ORDERING INFORMATION

**LY 8 010 VV**

V : Package Type  
 CL : 9-Ball WCSP  
 BL : 8-Pin DFN

Product Name

A : Product Line

LY : Lyontek Product Number Prefix

www.DataSheet4U.com

#### PACKAGE MARKING FORMAT (For WCSP Package only)

**AA B C**

C : Lot Number

B : Date Code

Product Name

#### APPLICATION CIRCUIT

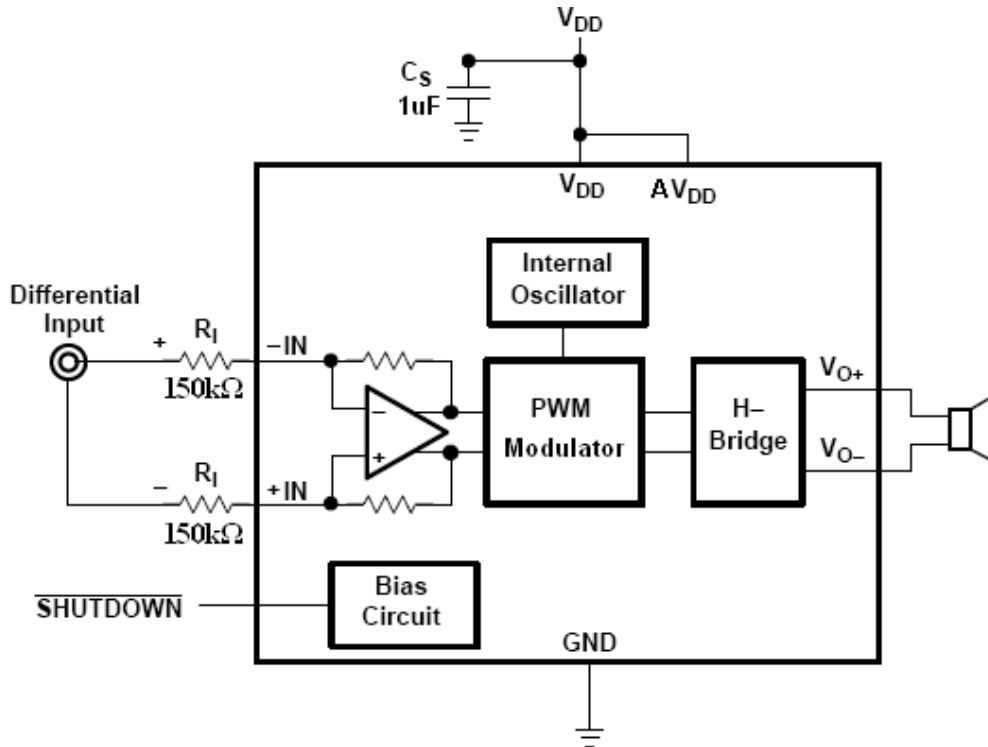


Figure 1. Application Schematic With Differential Input Configuration

www.DataSheet4U.com

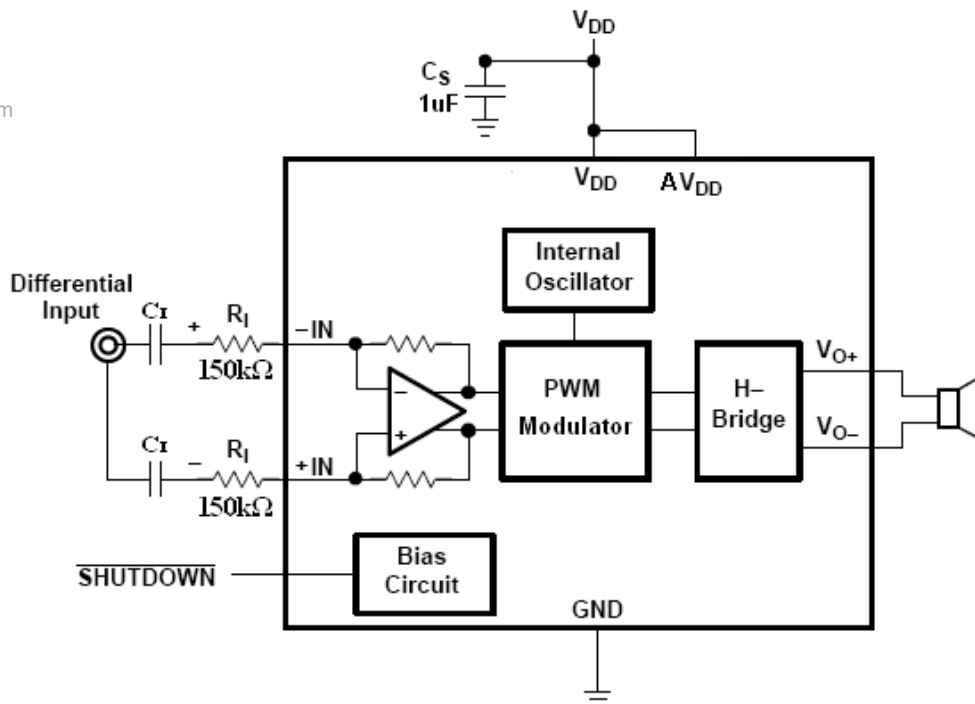


Figure 2. Application Schematic With Differential and Capacitors Input Configuration

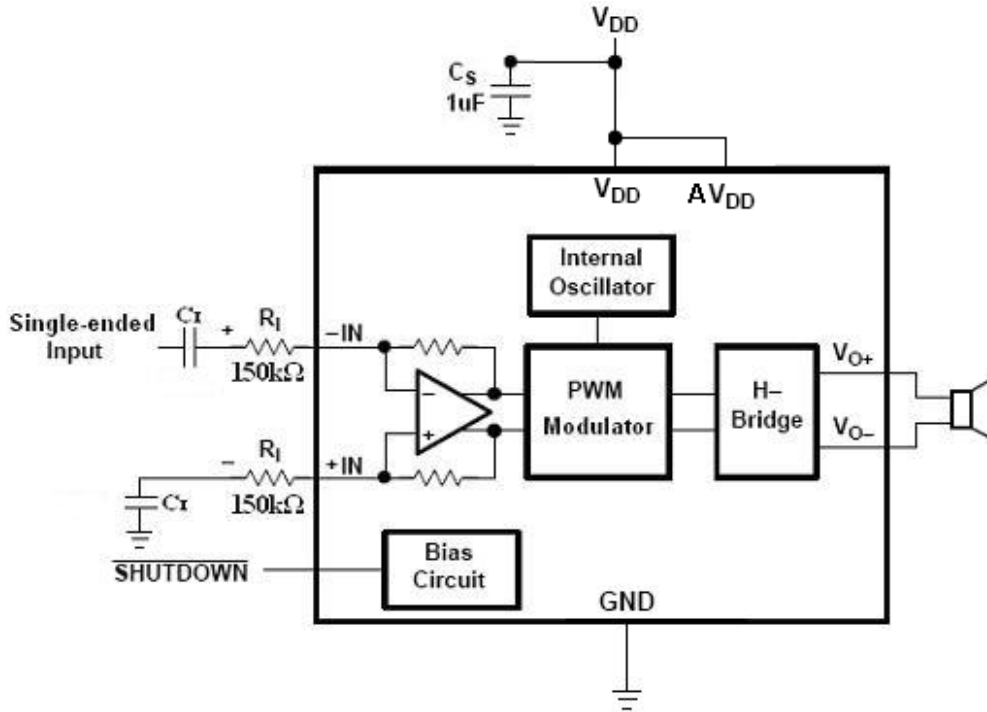


Figure 3. Application Schematic With Single-Ended Input

www.DataSheet4U.com **ABSOLUTE MAXIMUM RATINGS**

PARAMETER	SYMBOL	RATING	UNIT
Supply Voltage	$V_{DD}$	6.0	V
Operating Temperature	$T_A$	-40 to 85 (I grade)	$^{\circ}$ C
Input Voltage	$V_I$	-0.3V to $V_{DD}$ +0.3V	V
Storage Temperature	$T_{STG}$	-65 to 150	$^{\circ}$ C
Power Dissipation	$P_D$	Internally Limited	W
ESD Susceptibility	$V_{ESD}$	2000	V
Junction Temperature	$T_{JMAX}$	150	$^{\circ}$ C
Soldering Temperature (under 10 sec)	$T_{SOLDER}$	260	$^{\circ}$ C



**ELECTRICAL CHARACTERISTICS** ( $T_A = 25^\circ\text{C}$ , Unless otherwise noted)

PARAMETER	SYMBOL	TEST CONDITION	MIN.	TYP.	MAX.	UNIT
Output offset voltage (measured differentially)	$ V_{OS} $	$V_I = 0\text{ V}$ , $A_v = 2\text{ V/V}$ , $V_{DD} = 2.5\text{ V to }5.5\text{ V}$	-	-	25	mV
High-level input current	$ I_{IH} $	$V_{DD} = 5.5\text{ V}$ , $V_I = 5.8\text{ V}$	-	-	100	$\mu\text{A}$
Low-level input current	$ I_{IL} $	$V_{DD} = 5.5\text{ V}$ , $V_I = 0.3\text{ V}$	-	-	5	$\mu\text{A}$
Power supply rejection ratio	PSRR	$V_{DD} = 2.5\text{ V to }5.5\text{ V}$	-	-75	-55	dB
Common mode rejection ratio	CMRR	$V_{DD}=2.5\text{V to }5.5\text{V}$ , $V_{IC}= V_{DD}/2\text{ to }0.5\text{ V}$ , $V_{IC}= V_{DD}/2\text{ to }V_{DD}-0.8\text{ V}$ ,	-	-60	-48	dB
Quiescent Current	$I_Q$	$V_{DD} = 5.5\text{V}$ , No Load	-	3.4	4.5	mA
		$V_{DD} = 3.6\text{V}$ , No Load	-	2.8	-	
		$V_{DD} = 2.5\text{V}$ , No Load	-	2.2	3.2	
Shutdown Current	$I_{SD}$	$V_{SHUTDOWN} = 0.8\text{V}$ , $V_{DD} = 2.5\text{V to }5.5\text{V}$	-	0.3	2	$\mu\text{A}$

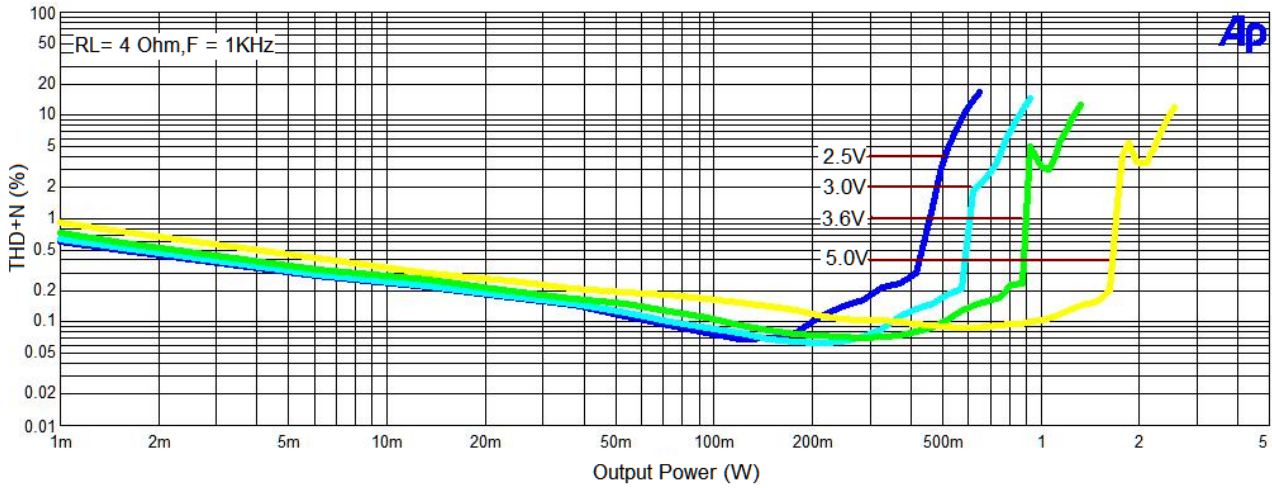
**OPERATING CHARACTERISTICS** ( $T_A = 25^\circ\text{C}$ , Gain = 2V/V,  $R_L = 8\Omega$ , Unless otherwise noted)

PARAMETER	SYMBOL	TEST CONDITION	MIN.	TYP.	MAX.	UNIT	
Out Power	$P_O$	THD+N= 10%, $f = 1\text{ kHz}$ , $R_L = 4\Omega$	$V_{DD}=5\text{V}$	-	2.5	-	W
			$V_{DD}=3.6\text{V}$	-	1.3	-	
			$V_{DD}=2.5\text{V}$	-	0.5	-	
		THD+N= 1%, $f = 1\text{ kHz}$ , $R_L = 4\Omega$	$V_{DD}=5\text{V}$	-	1.7	-	
			$V_{DD}=3.6\text{V}$	-	0.9	-	
			$V_{DD}=2.5\text{V}$	-	0.45	-	
		THD+N= 10%, $f = 1\text{ kHz}$ , $R_L = 8\Omega$	$V_{DD}=5\text{V}$	-	1.5	-	
			$V_{DD}=3.6\text{V}$	-	0.75	-	
			$V_{DD}=2.5\text{V}$	-	0.35	-	
		THD+N= 1%, $f = 1\text{ kHz}$ , $R_L = 8\Omega$	$V_{DD}=5\text{V}$	-	1.2	-	
			$V_{DD}=3.6\text{V}$	-	0.65	-	
			$V_{DD}=2.5\text{V}$	-	0.3	-	
Total harmonic distortion + noise	THD+N	$P_O = 1\text{ W}$ , $f = 1\text{ kHz}$ , $R_L = 8\Omega$	$V_{DD}=5\text{V}$	-	0.12	-	%
		$P_O = 0.5\text{ W}$ , $f = 1\text{ kHz}$ , $R_L = 8\Omega$	$V_{DD}=3.6\text{V}$	-	0.1	-	
		$P_O = 0.2\text{ W}$ , $f = 1\text{ kHz}$ , $R_L = 8\Omega$	$V_{DD}=2.5\text{V}$	-	0.08	-	
Supply ripple rejection ratio	$K_{SVR}$	$f = 217\text{ Hz}$ , $V_{(RIPPLE)} = 200\text{mVpp}$ , inputs ac-grounded with $C_i = 2\mu\text{F}$	$V_{DD}=3.6\text{V}$	-	-71	-	dB
Signal-to-noise ratio	SNR	$P_O = 1\text{ W}$ , $R_L = 8\Omega$	$V_{DD}=5\text{V}$	-	97	-	dB
Output voltage noise	$V_n$	$V_{DD} = 3.6\text{ V}$ , $f = 20\text{ Hz to }20\text{ kHz}$ , Inputs ac-grounded with $C_i = 2\mu\text{F}$	No weighting	-	48	-	$\mu\text{VRMS}$
			A weighting	-	36	-	
Common mode rejection ratio	CMRR	$V_{IC} = 1\text{ Vpp}$ , $f = 217\text{ Hz}$	$V_{DD}=3.6\text{V}$	-	-63	-	dB
Start-up time from shutdown	$Z_I$	$V_{DD} = 3.6\text{ V}$	-	1	-	ms	

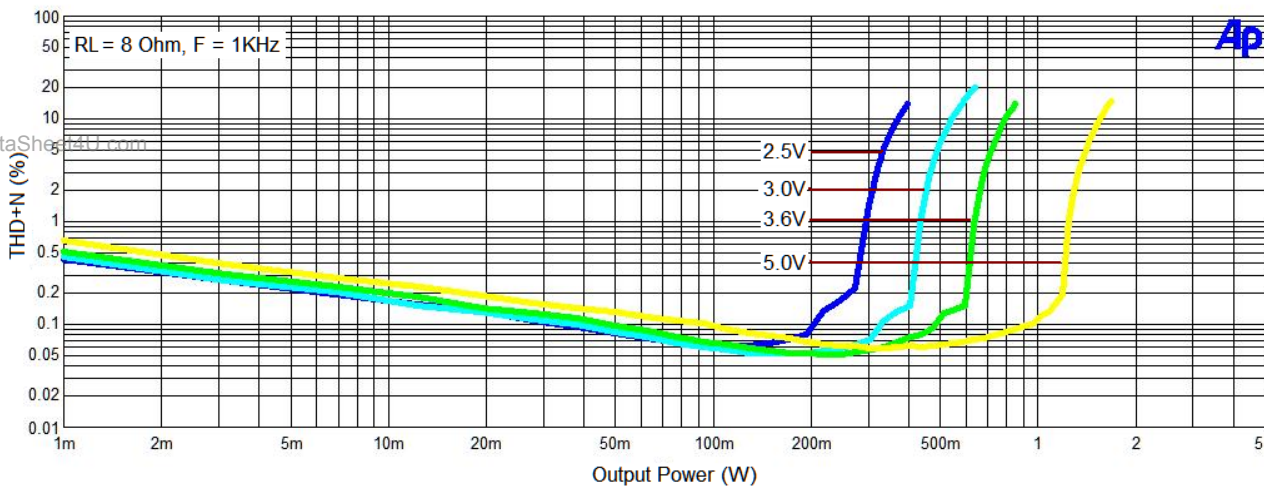


#### TYPICAL PERFORMANCE CHARACTERISTICS

**Figure 4**  
Total Harmonic Distortion + Noise vs Output Power

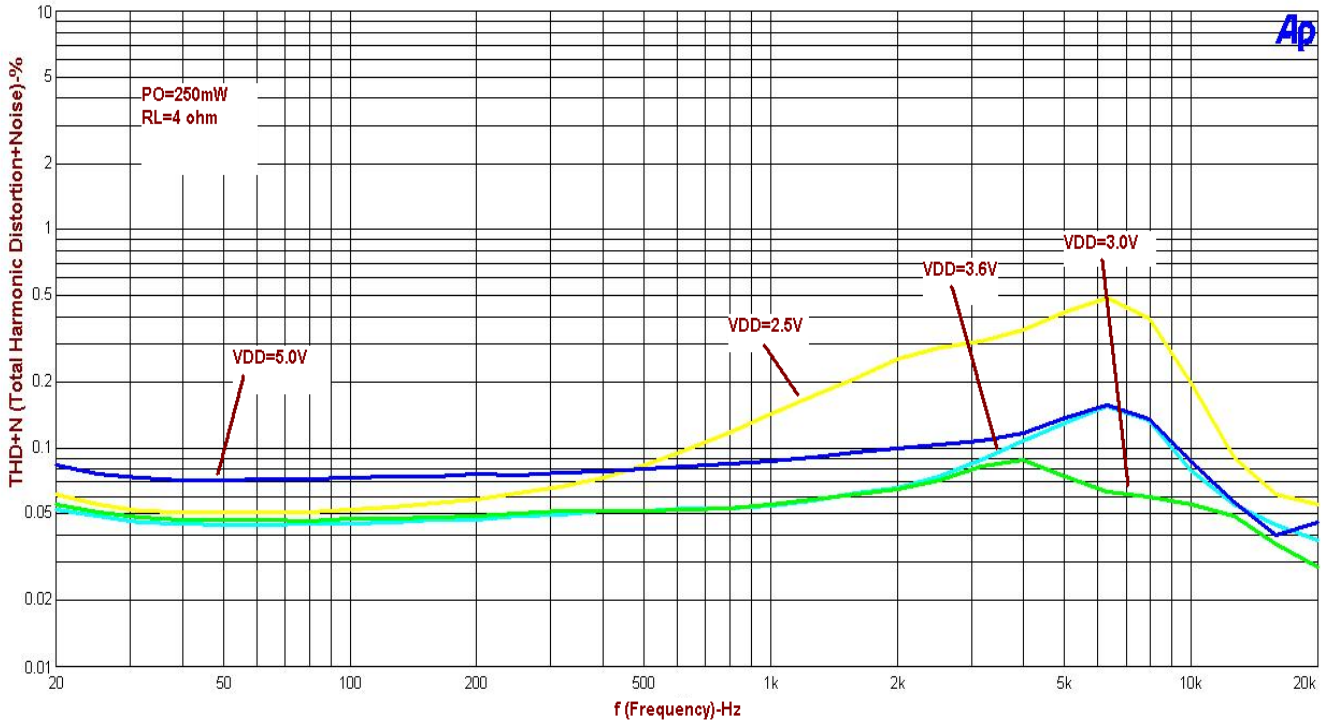


**Figure 5**  
Total Harmonic Distortion + Noise vs Output Power

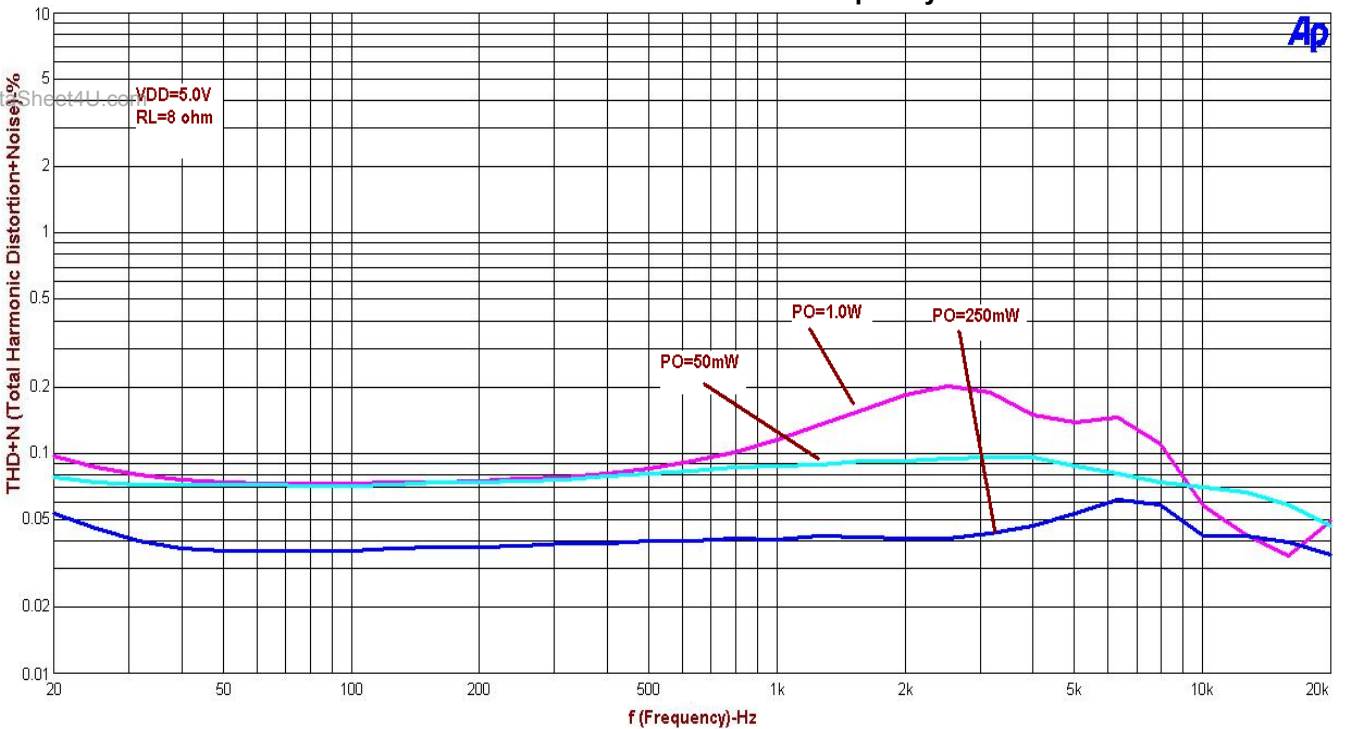




**Figure 6**  
Total Harmonic Distortion + Noise vs Frequency

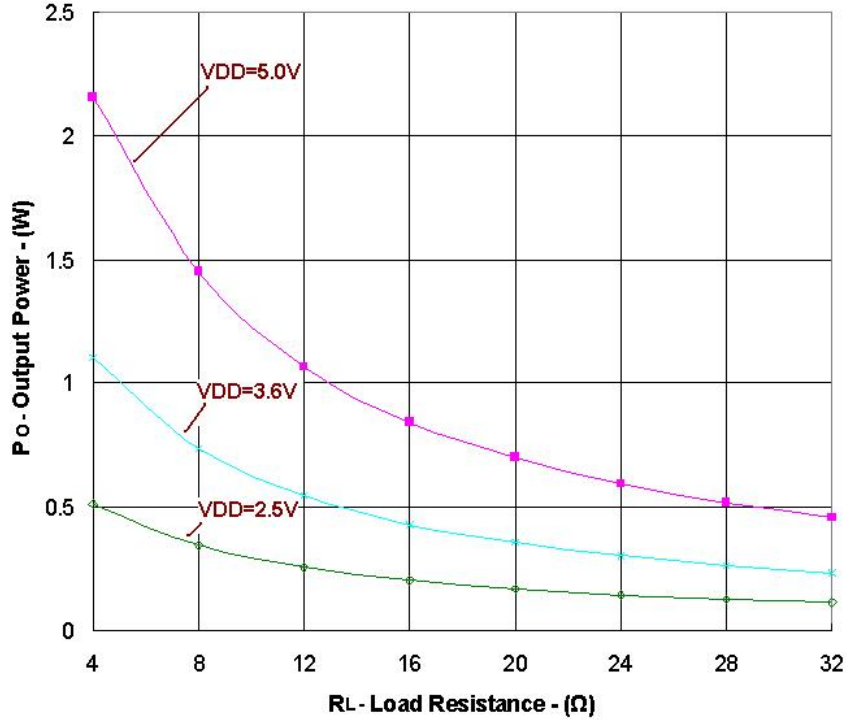


**Figure 7**  
Total Harmonic Distortion + Noise vs Frequency

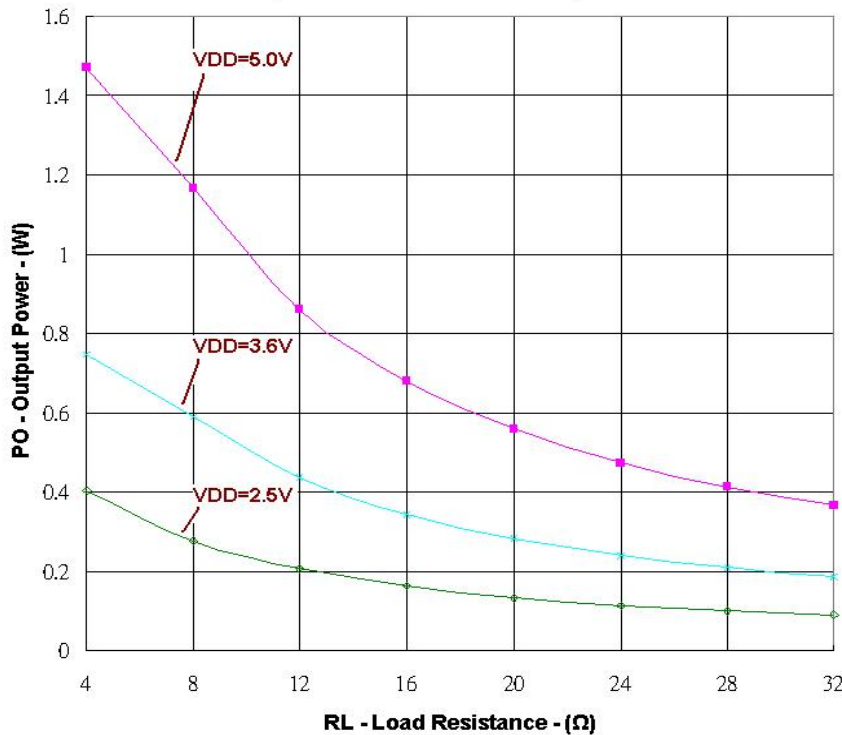




**Figure 8**  
Output Power vs Load Resistance ( $P_o$  at 10 % THD with  $f = 1$  kHz)



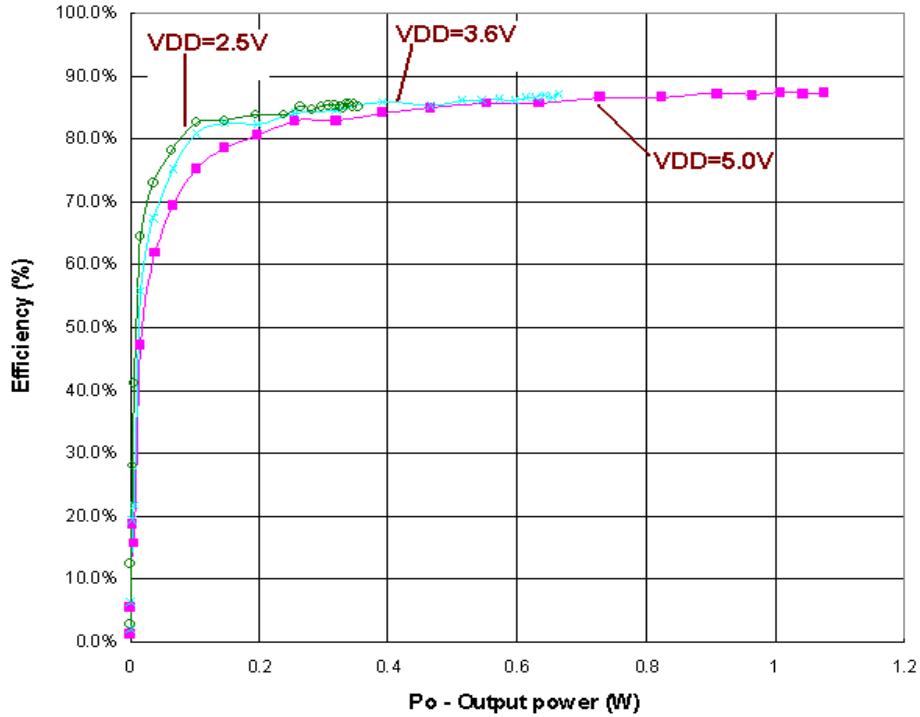
**Figure 9**  
Output Power vs Load Resistance ( $P_o$  at 1 % THD with  $f = 1$  kHz)



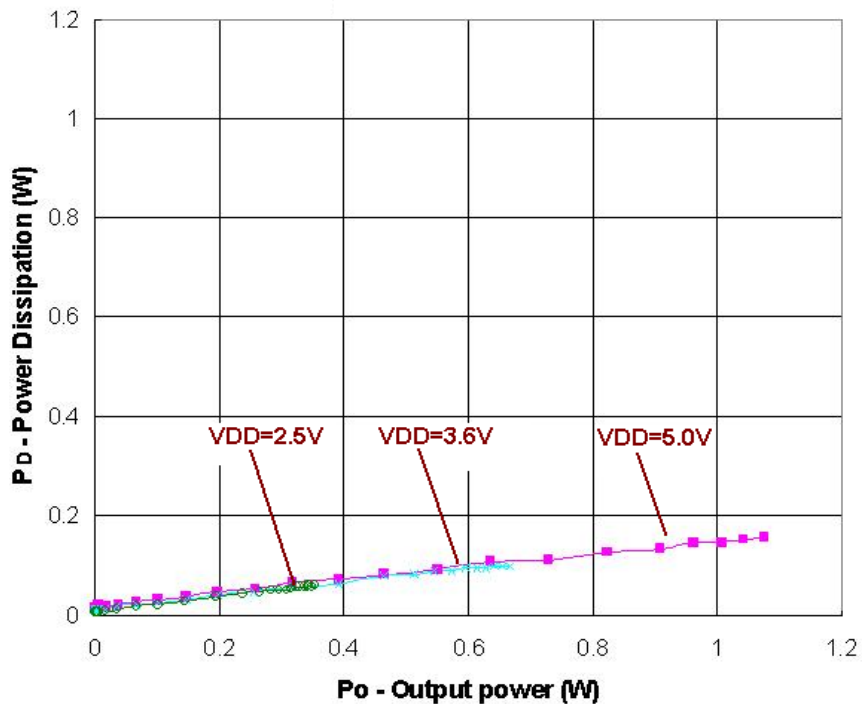
www.DataSheet4U.com



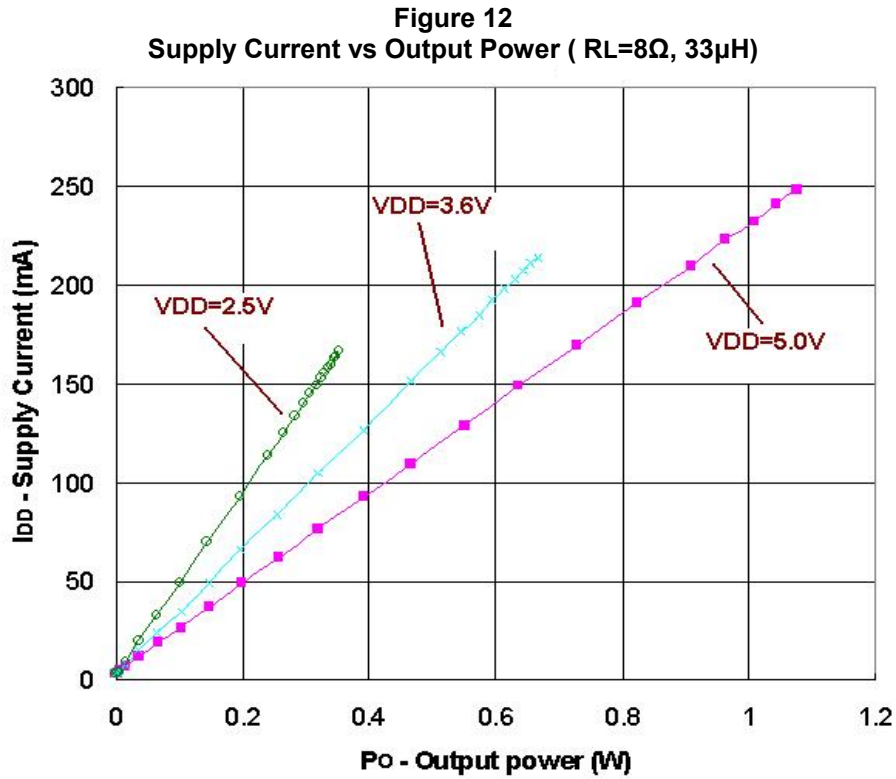
**Figure 10**  
Efficiency vs Output power (  $R_L=8\Omega, 33\mu H$  )



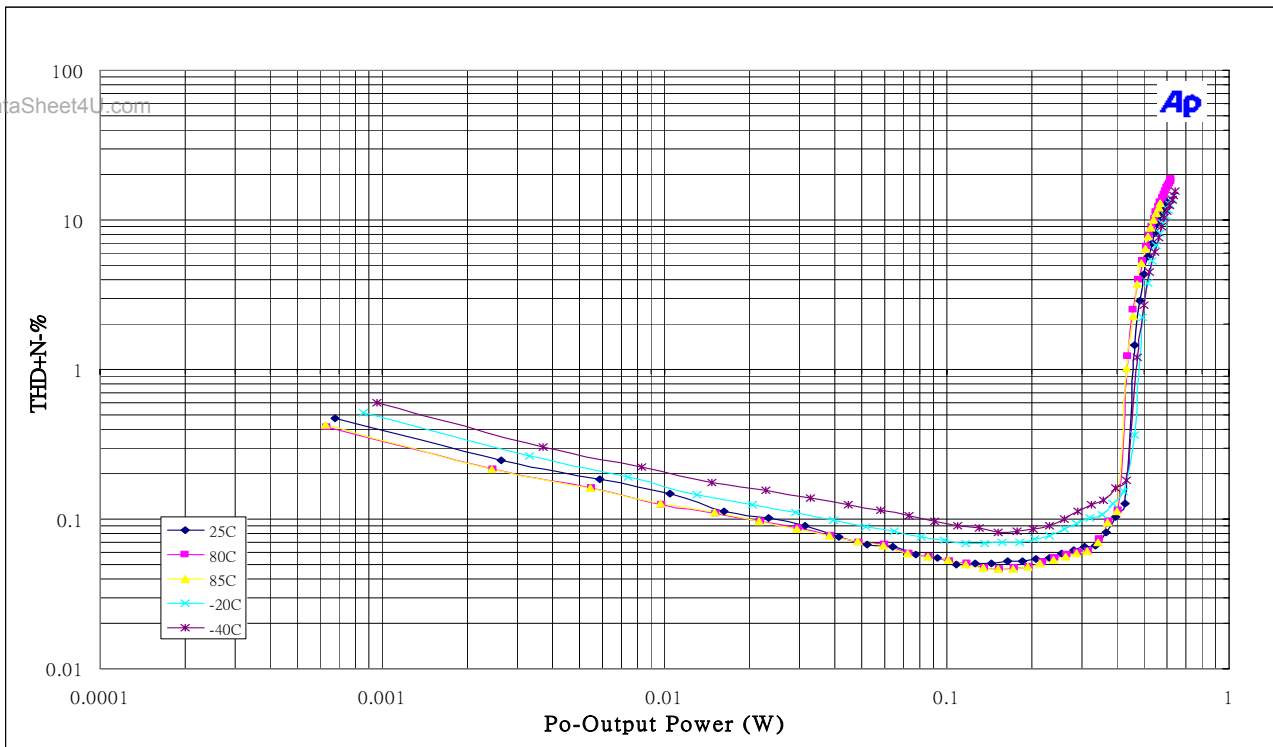
**Figure 11**  
Power dissipation vs Output power (  $R_L=8\Omega, 33\mu H$  )



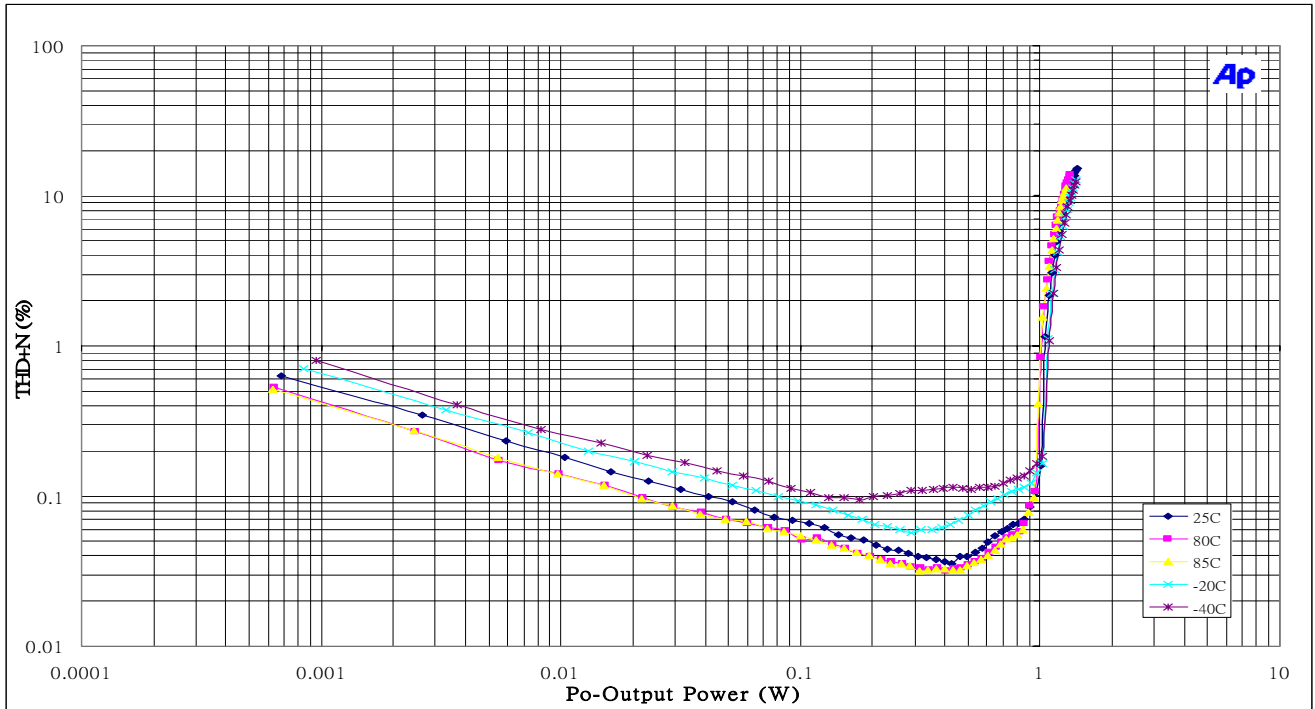
www.DataSheet4U.com



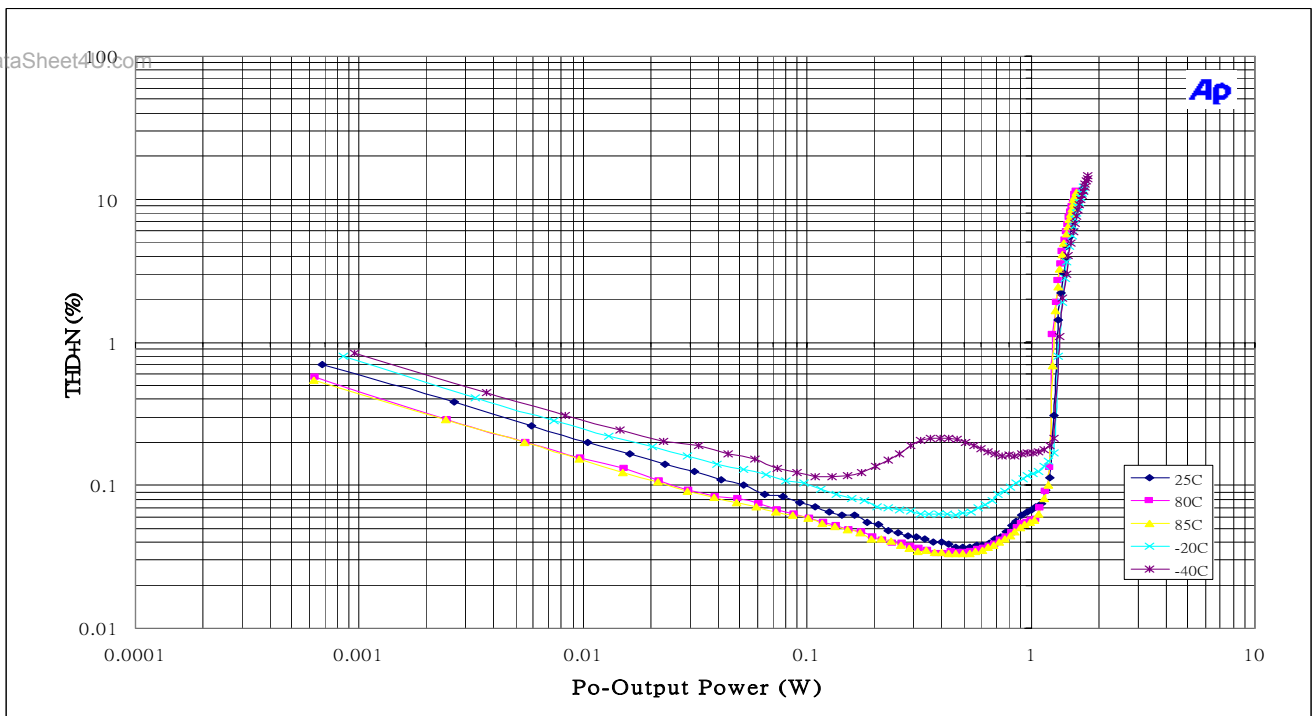
**Figure 13**  
THD+N & Output Power vs Temperature (V<sub>DD</sub>=3V, R<sub>L</sub>=8Ω)



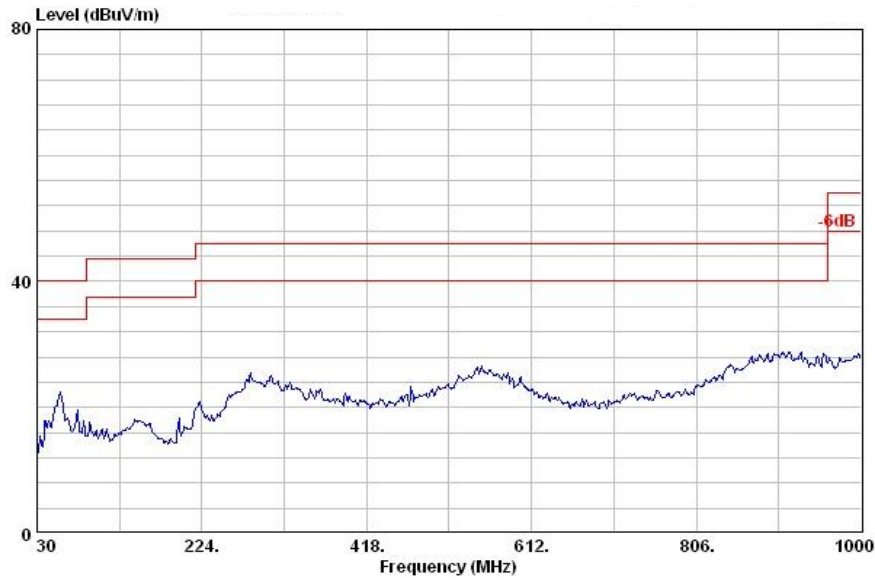
**Figure 14**  
THD+N & Output Power vs Temperature (V<sub>DD</sub>=4.5V, R<sub>L</sub>=8Ω)



**Figure 15**  
THD+N & Output Power vs Temperature (V<sub>DD</sub>=5.0V, R<sub>L</sub>=8Ω)



**Figure 16**  
FCC Class-B (Vertical)



Trace: (Discrete)

Site : site

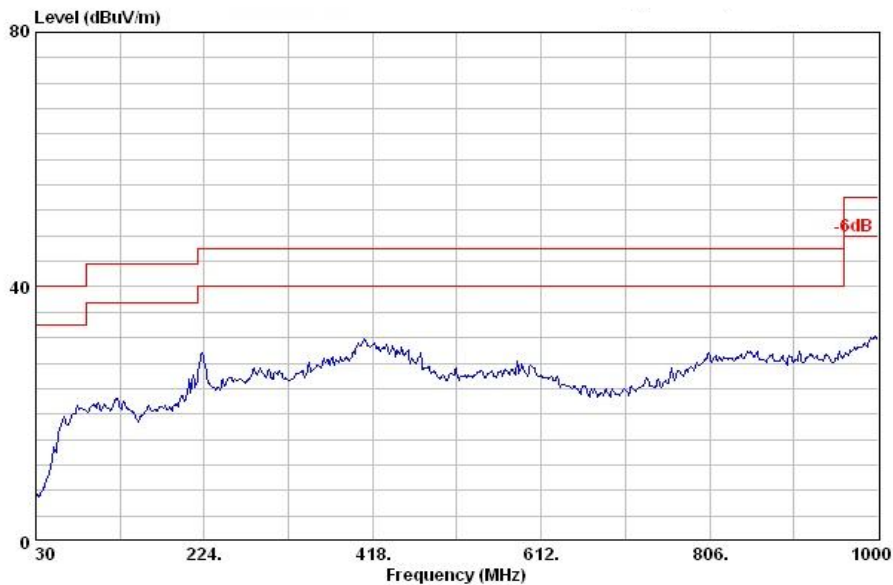
Condition : FCC CLASS-B 3m VERTICAL

EUT : LY8010

Voltage/Freq : DC/4.5V

Memo : GND+COPPER

**Figure 17**  
FCC Class-B (Horizontal)



Trace: (Discrete)

Site : site

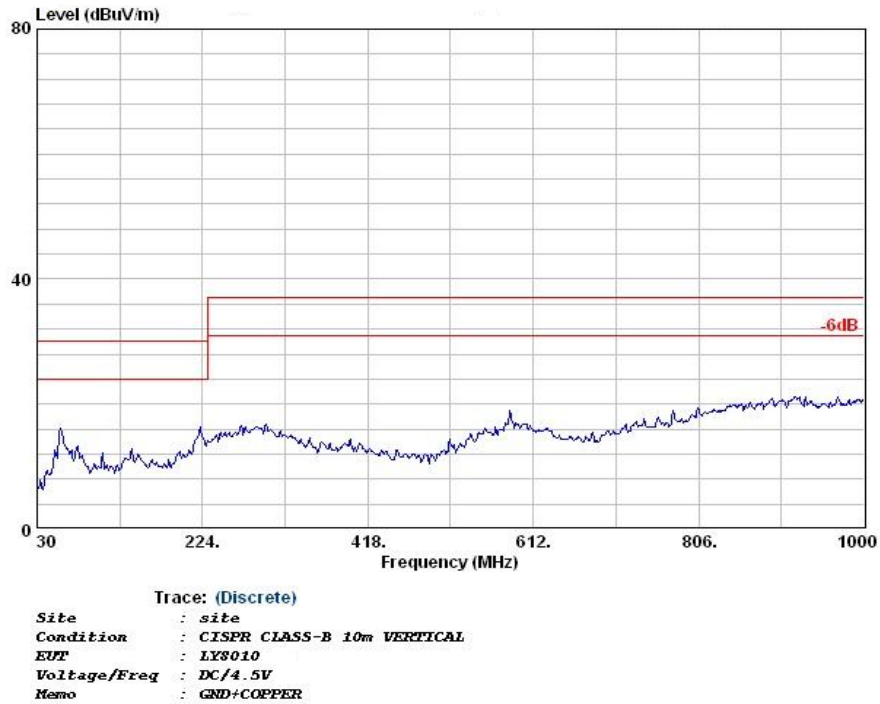
Condition : FCC CLASS-B 3m HORIZONTAL

EUT : LY8010

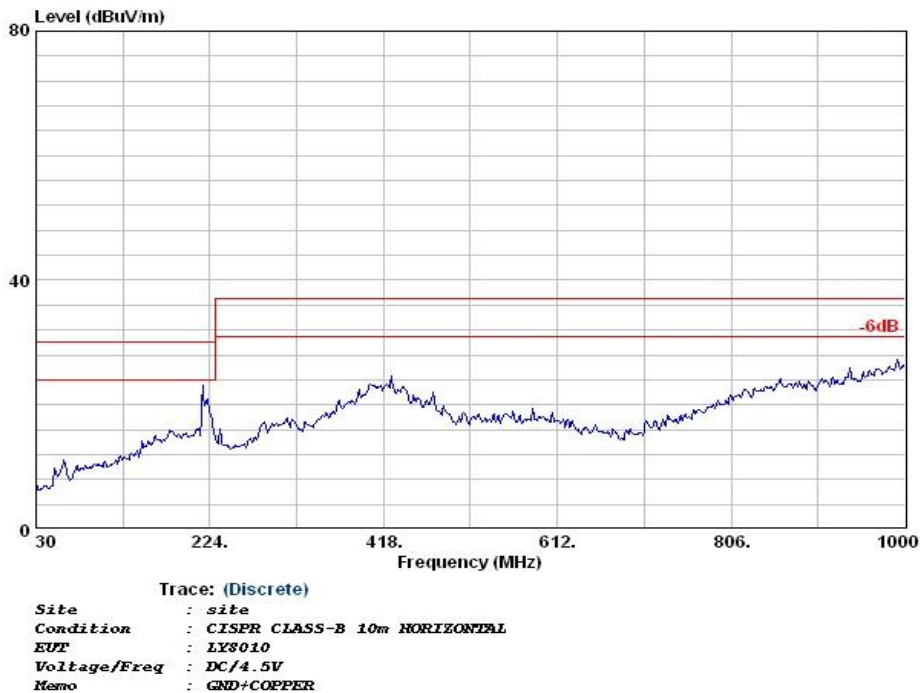
Voltage/Freq : DC/4.5V

Memo : GND+COPPER

**Figure 18**  
CISPR Class-B (Vertical)



**Figure 19**  
CISPR Class-B (Horizontal)





## APPLICATION INFORMATION

### Fully Differential Amplifier

The LY8010 is a fully differential amplifier with differential inputs and outputs. The fully differential amplifier consists of a differential amplifier and a common-mode amplifier. The differential amplifier ensures that the amplifier outputs a differential voltage on the output that is equal to the differential input times the gain. The common-mode feedback ensures that the common-mode voltage at the output is biased around  $V_{DD}/2$  regardless of the common-mode voltage at the input. The fully differential LY8010 can still be used with a single-ended input; however, the LY8010 should be used with differential inputs when in a noisy environment, like a wireless handset, to ensure maximum noise rejection.

### Advantages of Fully Differential Amplifiers

Input-coupling capacitors not required:

The fully differential amplifier allows the inputs to be biased at voltage other than mid-supply. For example, if a codec has a midsupply lower than the midsupply of the LY8010, the common-mode feedback circuit will adjust, and the LY8010 outputs will still be biased at midsupply of the LY8010. The inputs of the LY8010 can be biased from 0.5 V to  $V_{DD} - 0.8$  V. If the inputs are biased outside of that range, input - coupling capacitors are required.

Midsupply bypass capacitor,  $C_{(BYPASS)}$ , not required:

The fully differential amplifier does not require a bypass capacitor. This is because any shift in the midsupply affects both positive and negative channels equally and cancels at the differential output.

Better RF-immunity:

GSM handsets save power by turning on and shutting off the RF transmitter at a rate of 217 Hz. The transmitted signal is picked-up on input and output traces. The fully differential amplifier cancels the signal much better than the typical audio amplifier.

### Component Selection

Figure 1 shows the LY8010 typical schematic with differential inputs and Figure 2 shows the LY8010 with differential and capacitors inputs, and Figure 3 shows the LY8010 with single-ended inputs. Differential inputs should be used whenever possible because the single-ended inputs are much more susceptible to noise.

**Table 1. Typical Component Values**

Reference	Description	Note
Ri	150K $\Omega$	1% tolerance resistors
Cs	1.0uF	+22%,-80%
Ci	3.3nF	( $\pm 10\%$ )

(1) Ci is only needed for single-ended input or if  $V_{ICM}$  is not between 0.5 V and  $V_{DD} - 0.8$  V. Ci = 3.3 nF (with Ri = 150K $\Omega$ ) gives a high-pass corner frequency of 321 Hz.

For example

$$f_c = 1 / ( 2\pi R_i C_i )$$

$$f_c = 1 / ( 2\pi \times 150K\Omega \times 3.3nF ) = 321.524 \text{ Hz}$$



#### Input Resistors (Ri)

The input resistors (Ri) set the gain of the amplifier according to equation Equation 1.

$$\text{Pre-Amplifier Gain} = \frac{150 \text{ k}\Omega}{R_i}$$

$$\text{Total Gain} = 2 \times \frac{150 \text{ k}\Omega}{R_i} \dots\dots\dots(1)$$

$$A_{VD} = 20 \times \log \left[ 2 \times \left( \frac{150 \text{ k}\Omega}{R_i} \right) \right]$$

**Resistor matching is very important in fully differential amplifiers.** The balance of the output on the reference voltage depends on matched ratios of the resistors. CMRR, PSRR, and cancellation of the second harmonic distortion diminish if resistor mismatch occurs. Therefore, it is recommended to use 1% tolerance resistors or better to keep the performance optimized. Matching is more important than overall tolerance. Resistor arrays with 1% matching can be used with a tolerance greater than 1%. Place the input resistors very close to the LY8010 to limit noise injection on the high-impedance nodes. For optimal performance the gain should be set to 2 V/V or lower. Lower gain allows the LY8010 to operate at its best, and keeps a high voltage at the input making the inputs less susceptible to noise.

For example

**Table 2. Typical Total Gain and AvD Values**

Rf (KΩ)	150	150	150	150	150	150
Ri (KΩ)	150	75	50	37.5	25	18.75
Pre AMP. Gain	1	2	3	4	6	8
Total Gain	2	4	6	8	12	16
AvD (db)	6.02	12.04	15.56	18.06	21.58	24.08

#### Decoupling Capacitor (Cs)

The LY8010 is a high-performance class-D audio amplifier that requires adequate power supply decoupling to ensure the efficiency is high and total harmonic distortion (THD) is low. For higher frequency transients, spikes, or digital hash on the line, a good low equivalent-series-resistance (ESR) ceramic capacitor, typically 1 μF, placed as close as possible to the device VDD lead works best. Placing this decoupling capacitor close to the LY8010 is very important for the efficiency of the class-D amplifier, because any resistance or inductance in the trace between the device and the capacitor can cause a loss in efficiency. For filtering lower-frequency noise signals, a 10 μF or greater capacitor placed near the audio power amplifier would also help, but it is not required in most applications because of the high PSRR of this device.





#### Input Capacitors (Ci)

The LY8010 does not require input coupling capacitors if the design uses a differential source that is biased from 0.5 V to  $V_{DD} - 0.8$  V (shown in Figure 1). If the input signal is not biased within the recommended common-mode input range, if needing to use the input as a high pass filter (shown in Figure 2), or if using a single-ended source (shown in Figure 3), input coupling capacitors are required. The input capacitors and input resistors form a high-pass filter with the corner frequency,  $f_c$ , determined in equation Equation 2.

$$f_c = \frac{1}{2\pi R_i C_i} \dots \dots \dots (2)$$

The value of the input capacitor is important to consider as it directly affects the bass (low frequency) performance of the circuit. Speakers in wireless phones cannot usually respond well to low frequencies, so the corner frequency can be set to block low frequencies in this application. Equation Equation 3 is reconfigured to solve for the input coupling capacitance.

$$C_i = \frac{1}{2\pi R_i f_c} \dots \dots \dots (3)$$

#### For example

In the table 3 shows the external components.  $R_{in}$  in connect with  $C_{in}$  to create a high-pass filter.

**Table 3. Typical Component Values**

Reference	Description	Note
$R_i$	150K $\Omega$	1% tolerance resistors
$C_i$	0.22 $\mu$ F	80%/–20%

www.DataSheet4U.com

$$C_i = 1 / ( 2\pi R_i f_c )$$

$$C_i = 1 / ( 2\pi \times 150K\Omega \times 4.8Hz ) = 0.221\mu F \cdot \text{Use } 0.22\mu F$$

#### Summing Input Signals With The LY8010

Most wireless phones or PDAs need to sum signals at the audio power amplifier or just have two signal sources that need separate gain. The LY8010 makes it easy to sum signals or use separate signal sources with different gains. Many phones now use the same speaker for the earpiece and ringer, where the wireless phone would require a much lower gain for the phone earpiece than for the ringer. PDAs and phones that have stereo headphones require summing of the right and left channels to output the stereo signal to the mono speaker.

#### Summing Two Differential Input Signals

Two extra resistors are needed for summing differential signals (a total of 5 components). The gain for each input source can be set independently (see equations Equation 4 and Equation 5, and Figure 20).

$$\text{Gain 1} = \frac{V_o}{V_{i1}} = 2 \times \frac{150\text{k}\Omega}{R_{i1}} \dots\dots\dots(4)$$

$$\text{Gain 2} = \frac{V_o}{V_{i2}} = 2 \times \frac{150\text{k}\Omega}{R_{i2}} \dots\dots\dots(5)$$

If summing left and right inputs with a gain of 1 V/V, use  $R_{i1} = R_{i2} = 300 \text{ k}\Omega$   
 If summing a ring tone and a phone signal, set the ring-tone gain to  $\text{Gain 2} = 2 \text{ V/V}$ , and the phone gain to  $\text{gain 1} = 0.1 \text{ V/V}$ . The resistor values would be . . .

$R_{i1} = 3 \text{ M}\Omega$ , and  $R_{i2} = 150 \text{ k}\Omega$ .

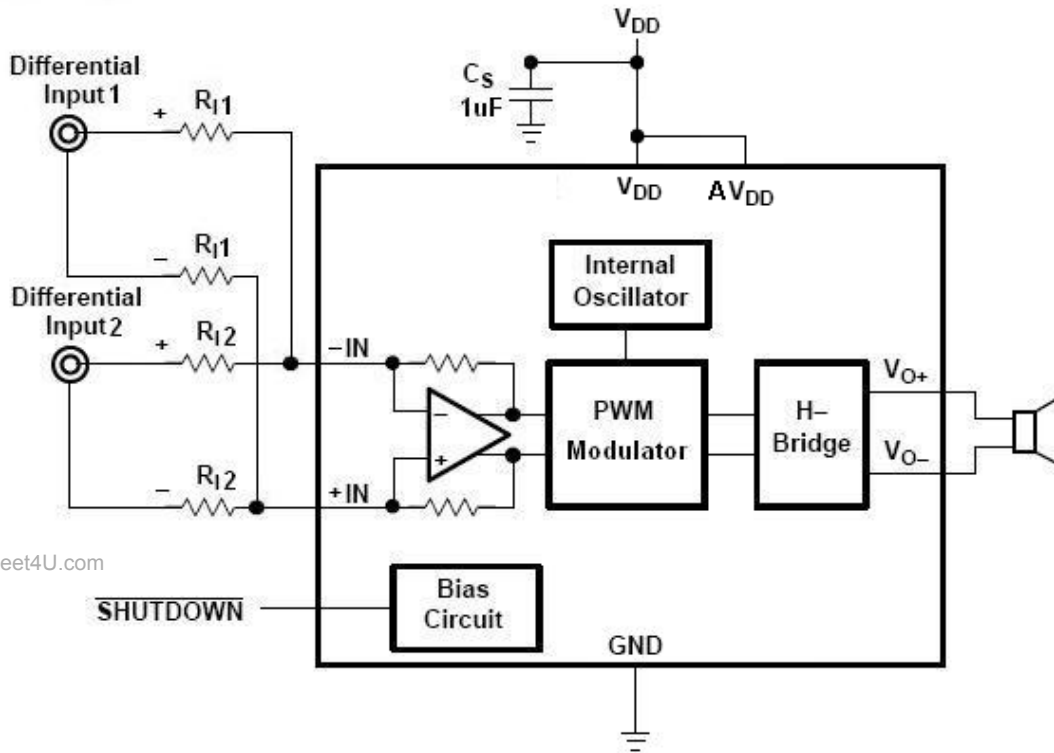


Figure 20. Application Schematic With LY8010 Summing Two Differential Input

#### Summing a Differential Input Signal and a Single-Ended Input Signal

Figure 21 shows how to sum a differential input signal and a single-ended input signal. Ground noise can couple in through  $IN+$  with this method. It is better to use differential inputs. The corner frequency of the single-ended input is set by  $C_{i2}$ , shown in equation Equation 8. To assure that each input is balanced, the single-ended input must be driven by a low-impedance source even if the input is not in use.

$$\text{Gain 1} = \frac{V_o}{V_{i1}} = 2 \times \frac{150\text{k}\Omega}{R_{i1}} \dots\dots\dots(6)$$

$$\text{Gain } 2 = \frac{V_o}{V_{i2}} = 2 \times \frac{150\text{k}\Omega}{R_{i2}} \dots\dots\dots(7)$$

$$C_{i2} = \frac{1}{2\pi R_{i2} f_{c2}} \dots\dots\dots(8)$$

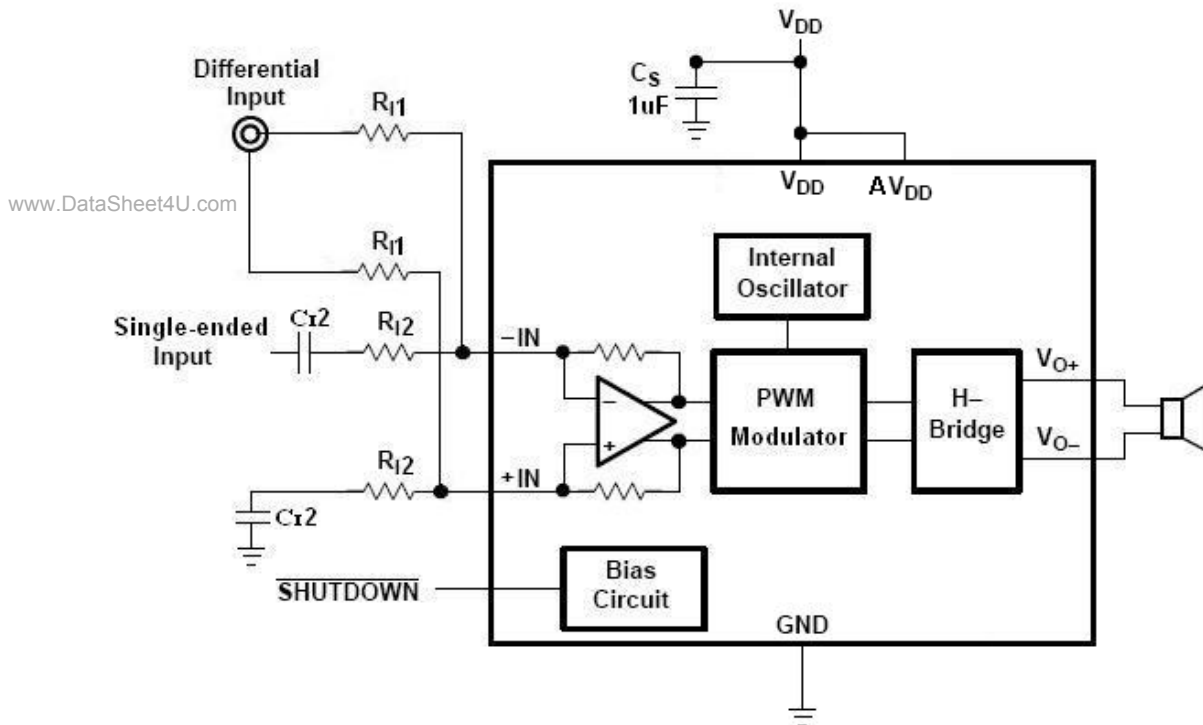
If summing a ring tone and a phone signal, the phone signal should use a differential input signal while the ring tone might be limited to a single-ended signal. Phone gain is set at gain 1 = 0.1 V/V, and the ring-tone gain is set to gain 2 = 2 V/V, the resistor values would be ...

$R_{i1} = 3 \text{ M}\Omega$ , and  $R_{i2} = 150 \text{ k}\Omega$ .

The high pass corner frequency of the single-ended input is set by  $C_{i2}$ . If the desired corner frequency is less than 20 Hz.

$$C_{i2} > \frac{1}{2\pi \cdot 150\text{k}\Omega \cdot 20\text{Hz}} \dots\dots\dots(9)$$

$$C_{i2} > 53\text{pF} \dots\dots\dots(10)$$



**Figure 21. Application Schematic With LY8010 Summing Differential and Sing-Ended Input**

**Summing Two Single-Ended Input Signals**

Four resistors and three capacitors are needed for summing single-ended input signals. The gain and corner frequencies ( $f_{c1}$  and  $f_{c2}$ ) for each input source can be set independently (see equations Equation 11 through Equation 14, and Figure 22). Resistor,  $R_P$ , and capacitor,  $C_P$ , are needed on the IN+ terminal to match the impedance on the IN- terminal. The single-ended inputs must be driven by low impedance sources even if one of the inputs is not outputting an ac signal.

$$\text{Gain 1} = \frac{V_o}{V_{i1}} = 2 \times \frac{150 \text{ k}\Omega}{R_{i1}} \dots\dots\dots(11)$$

$$\text{Gain 2} = \frac{V_o}{V_{i2}} = 2 \times \frac{150 \text{ k}\Omega}{R_{i2}} \dots\dots\dots(12)$$

$$C_{i1} = \frac{1}{2\pi R_{i1} f_{c1}} \dots\dots\dots(13)$$

$$C_{i2} = \frac{1}{2\pi R_{i2} f_{c2}} \dots\dots\dots(14)$$

$$C_P = C_{i1} + C_{i2} \dots\dots\dots(15)$$

$$R_P = \frac{R_{i1} \times R_{i2}}{R_{i1} + R_{i2}} \dots\dots\dots(16)$$

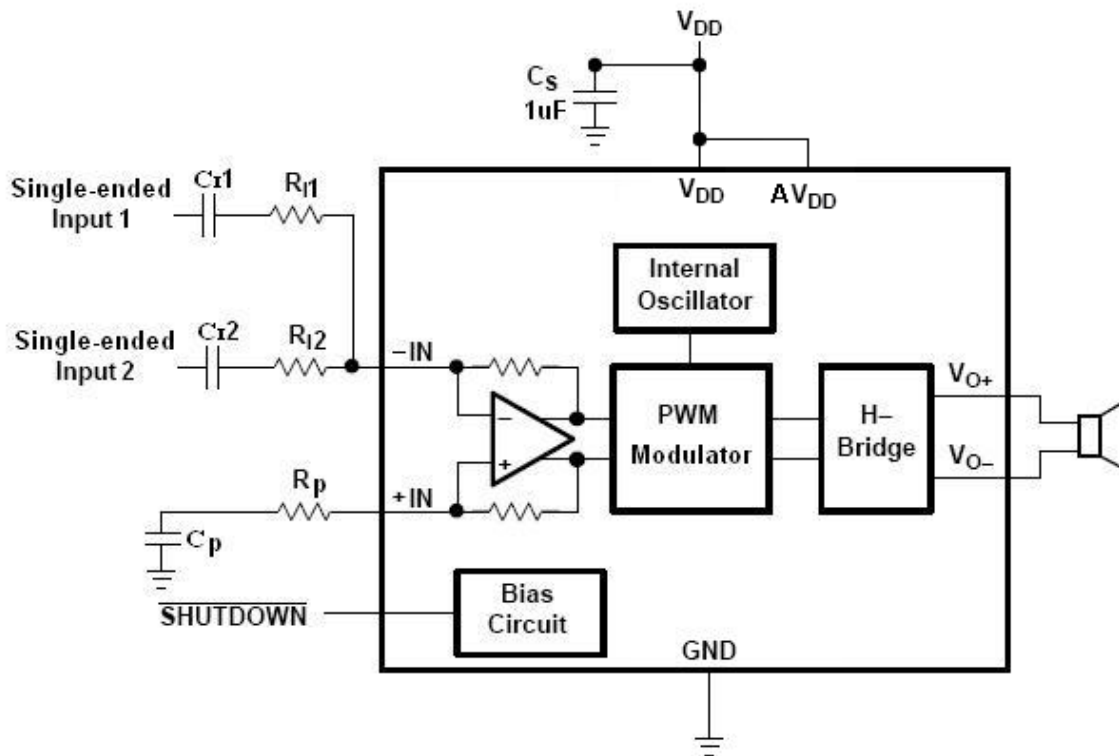


Figure 22. Application Schematic With LY8010 Summing Two Single-ended Input

### PCB Layout

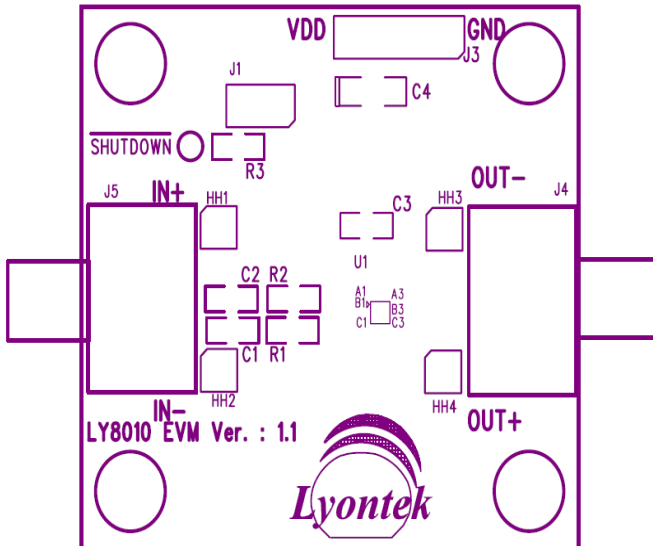
www.DataSheet4U.com

All the external components must place very close to the LY8010. The input resistors need to be very close to the LY8010 input pins so noise does not couple on the high impedance nodes between the input resistors and the input amplifier of the LY8010. Then place the decoupling capacitor  $C_s$ , close to the LY8010 is important for the efficiency of the class-D amplifier. Any resistance or inductance in the trace between the device and the capacitor can cause a loss in efficiency.

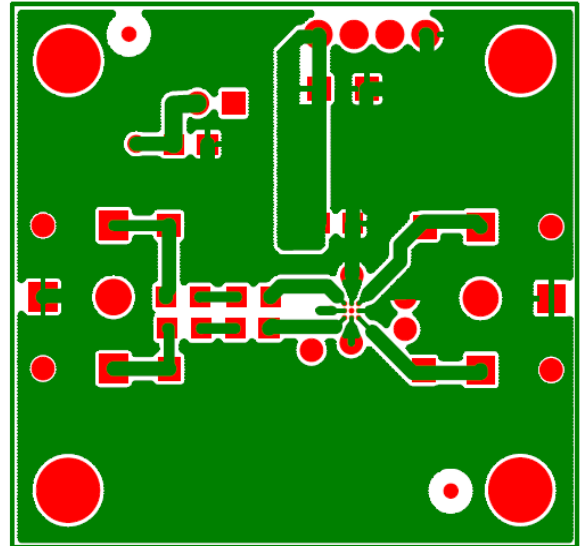
Making the high current traces going to VDD, GND,  $V_{O+}$  and  $V_{O-}$  pins of the LY8010 should be as wide as possible to minimize trace resistance. If these traces are too thin, the LY8010's performance and output power will decrease. The input traces do not need to be wide, but do need to run side-by-side to enable common-mode noise cancellation.

#### LY8010CL Demo Board Artwork

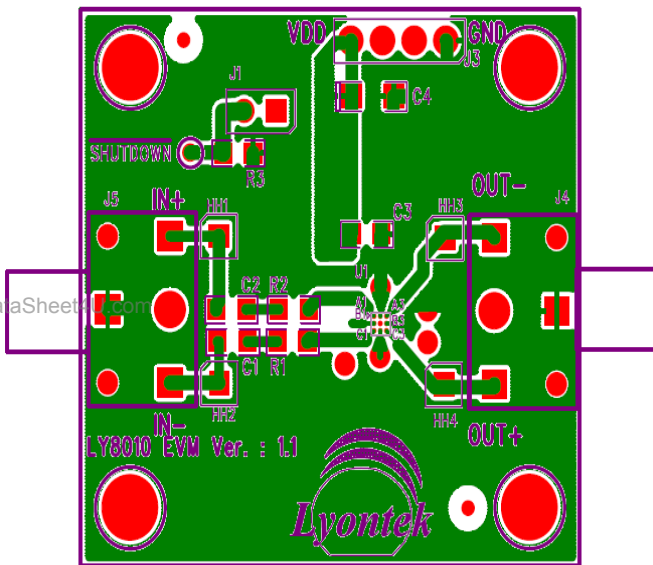
Top Silkscreen



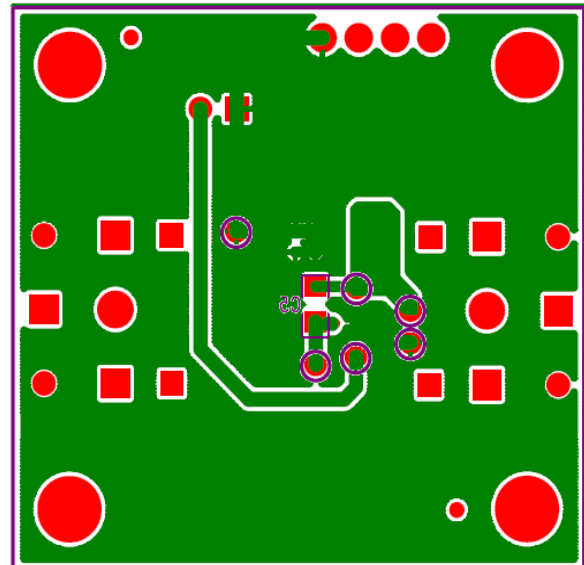
Top Layer



Composite view



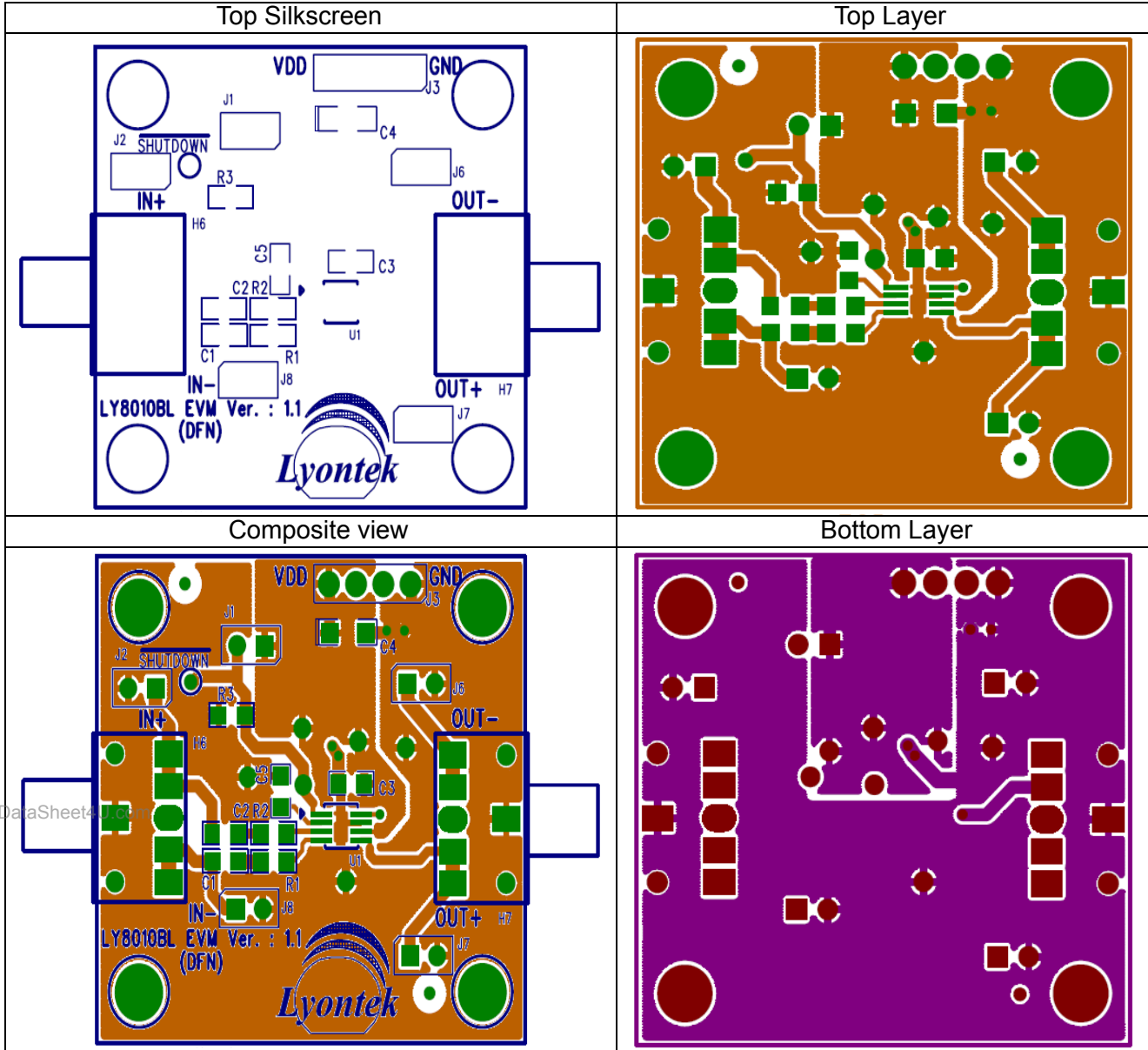
Bottom Layer



LY8010CL V1.1 BOM List

No.	Description	Reference	Note
1	Resistor, 150KΩ	R1,R2,R3	
2	Capacitor, 0.1uF	C3,C5	
3	Capacitor, 0.22uF	C1,C2	
4	Capacitor, 10.0uF	C4	
5	LY8010CL	U1	
6	1*2 Pin Header	J1	Close → Active

#### LY8010BL Demo Board Artwork



LY8010BL V1.1 BOM List

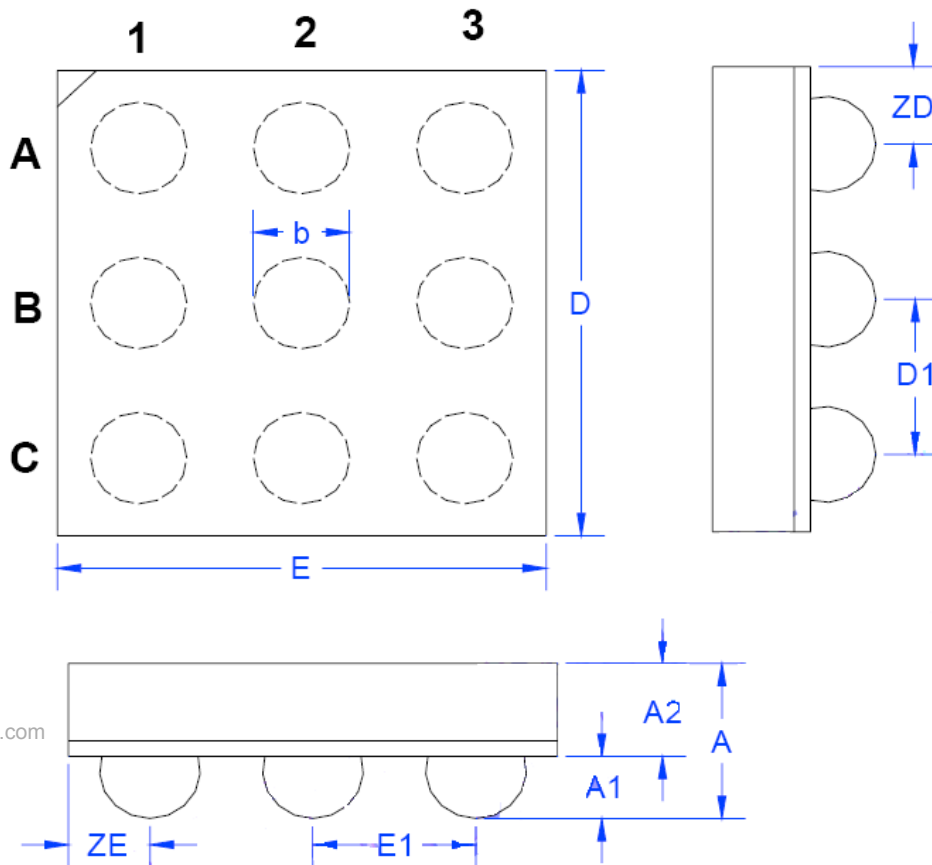
No.	Description	Reference	Note
1	Resistor, 150KΩ	R1,R2,R3	
2	Capacitor, 0.1uF	C3	
3	Capacitor, 0.22uF	C1,C2	
4	Capacitor, 10.0uF	C4	
5	LY8010BL	U1	
6	1*2 Pin Header	J1	Close → Active



#### PACKAGE OUTLINE DIMENSION

#### 9 Ball WCSP Package Outline Dimension

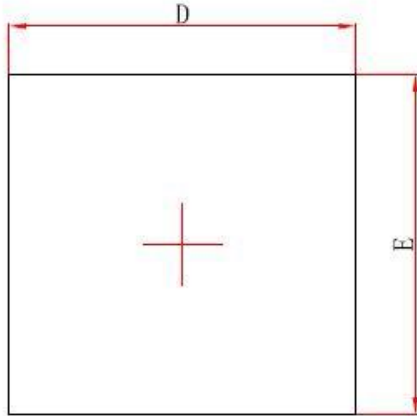
Top View



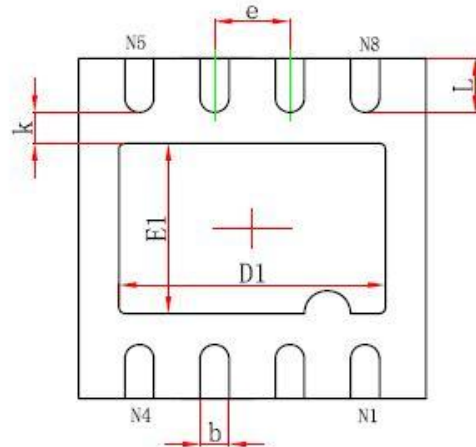
www.DataSheet4U.com

SYMBOL	DIMENSION(mm)		
	MIN	NOM	MAX
A			0.675
A1	0.200	0.230	0.260
A2	0.4000	0.4075	0.4150
b	0.270	0.320	0.370
E	1.450	1.500	1.550
D	1.450	1.500	1.550
D1		0.500	
E1		0.500	
ZD		0.230	
ZE		0.230	

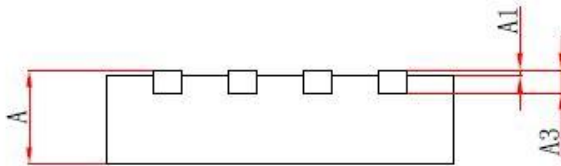
#### 8 Pin DFN Package Outline Dimension



**Top View**



**Bottom View**



**Side View**

www.DataSheet4U.com

Symbol	Dimensions In Millimeters	
	Min.	Max.
A	0.700/0.800	0.800/0.900
A1	0.000	0.050
A3	0.203REF.	
D	2.900	3.100
E	2.900	3.100
D1	2.200	2.400
E1	1.400	1.600
k	0.200MIN.	
b	0.180	0.300
e	0.650TYP.	
L	0.375	0.575