

LZ1134R

32-Unit High Voltage MOS IC

Description

The LZ1134R is a high voltage (300V) 32-output-port monolithic IC fabricated using Sharp's advanced P-channel DMOS process. It can be used as a matrix driver for electroluminescent panels, plasma display panels, electrostatic printers.

Features

1. High voltage output $\sim 300V$
2. Output current $-45mA$ (TYP: $V_{HVO} = -250V$)
3. Internal 32-bit shift register circuit
4. Expandable circuit structure
5. High speed data transfer (clock frequency 2 MHz)
6. Single power supply: $-5V$
7. DMOS process
8. 44-pin quad-flat package (Reversed bend pin)

Pin Connections

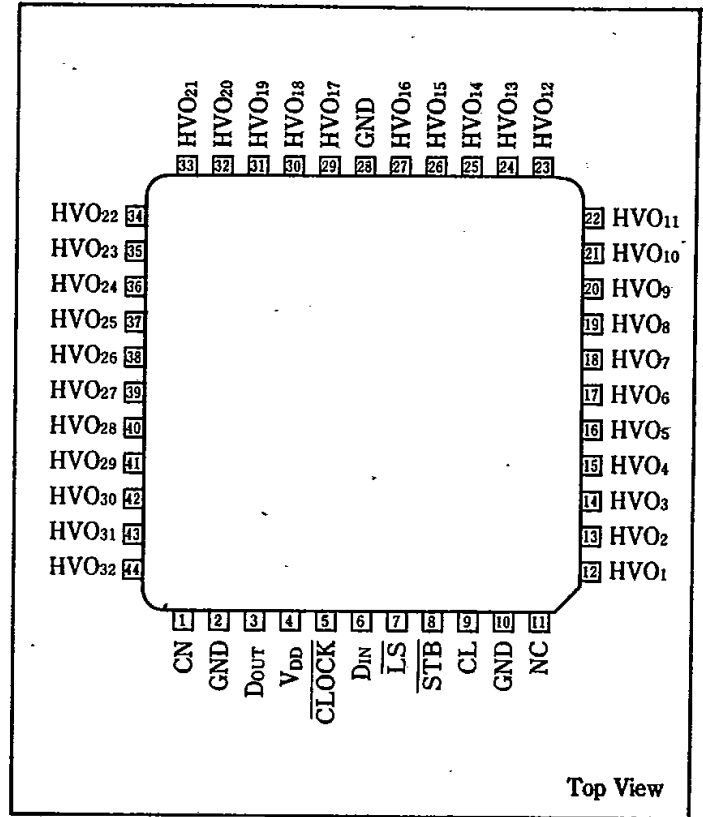

Block Diagram

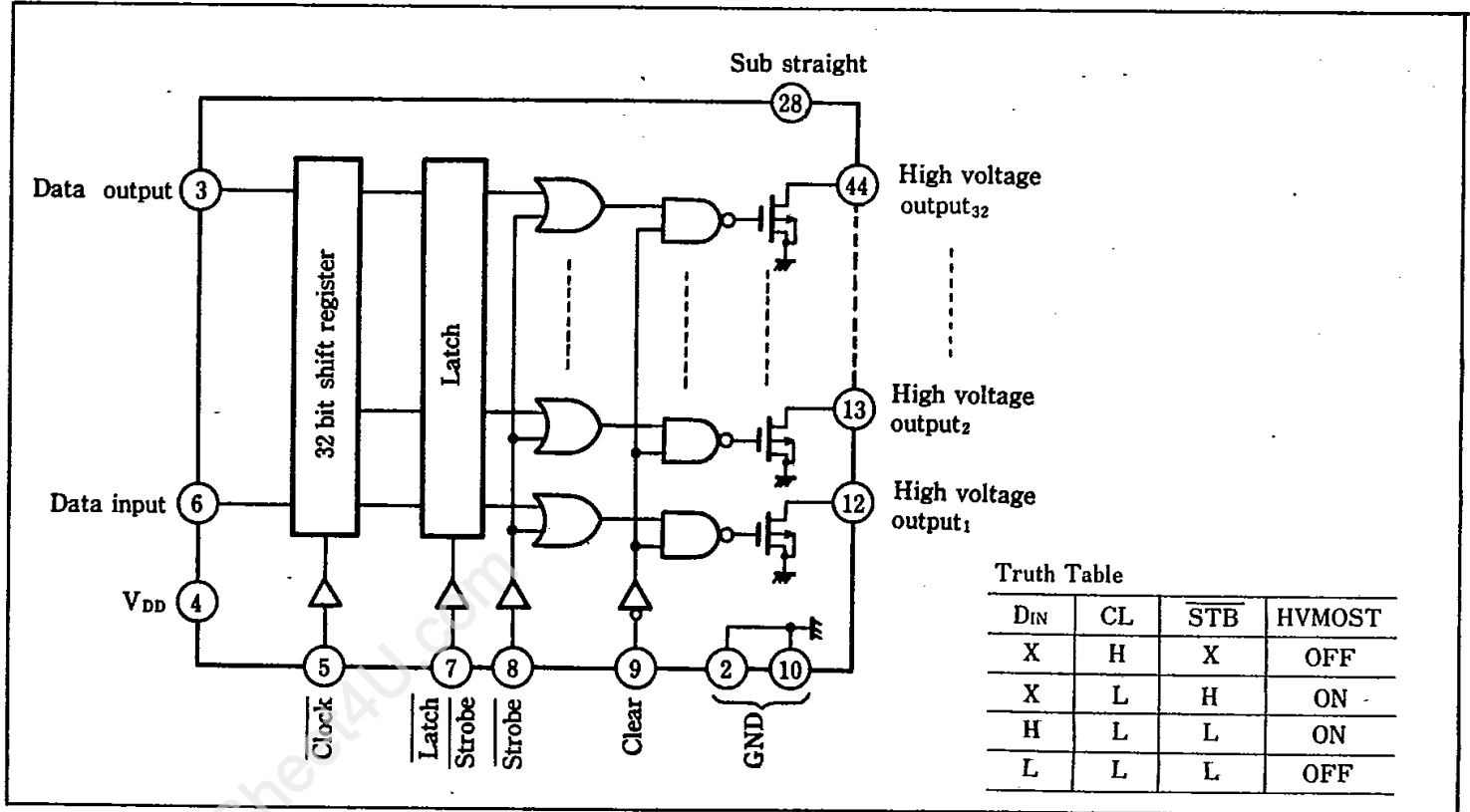

SHARP

Absolute Maximum Ratings

(Ta=25°C)

Parameter	Symbol	Conditions	Rating	Unit	Note
Supply voltage	V _{DD}		-7 to +0.3	V	1
Input voltage	V _{IN}	Applied to all input pins	-7 to +0.3	V	1
Output voltage	V _{OUT}	Applied to the data output	-7 to +0.3	V	1
	V _{HVO(ON)}		-300 to +0.3	V	1, 2
	V _{HVO(OFF)}		-350 to +0.3	V	1, 3
Power consumption	P _D	Ta ≤ 25°C	600	mW	
Derating ratio	ΔP _D /°C	Ta > +25°C	5	mW/°C	
Operating temperature	T _{opr}		-20 to +70	°C	
Storage temperature	T _{stg}		-55 to +150	°C	

Note 1 : The maximum applicable voltage on any pin with respect to GND.

Note 2 : The maximum applicable voltage when HVMOST is ON. D (duty cycle)=0.1% ON time=10 μs.

Note 3 : The maximum applicable voltage when HVMOST is OFF.

DC Characteristics

(1) HVMOST Characteristics

(V_{DD} = -5V ± 10%)

Parameter	Symbol	Conditions	MIN.	TYP.	MAX.	Unit	Note
ON-state resistance	R _{ON}	HVMOST "ON" I _{HVO} = -1mA, Ta = 25°C	460	590	720	Ω	
Drain current	I _{HVO}	HVMOST "ON" V _{HVO} = -300V, Ta = 25°C	-45			mA	1
Output leakage current	I _L	HVMOST "OFF" V _{HVO} = -300V, Ta = -20 to +70°C			-10	μA	2
Total output leakage current	I _{TL}	HVMOST "OFF" V _{HVO} = -300V, Ta = -20 to +70°C			-30	μA	3

Note 1 : Duty cycle=0.1%, ON time=10 μs.

Note 2 : Value for each HVMOST output pin.

Note 3 : Sum of total output leakage current.

(2) Logic Section Characteristics

(V_{DD} = -5V ± 10%, Ta = -20 to +70°C)

Parameter	Symbol	Conditions	MIN.	TYP.	MAX.	Unit
Supply voltage	I _{DD}	V _{IN} = 0V		-8	-16	mA
Input high voltage	V _{IH}		-0.8		0.3	V
Input low voltage	V _{IL}		V _{CC}		-2.4	V
Output high voltage	V _{OH}	I _{OH} = -0.2mA	-0.5			V
Output low voltage	V _{OL}	I _{OL} = 0.6mA			-2.5	V
Input leakage current	I _{IL}	V _{IN} = 0V to V _{CC}			10	μA

Note : Typical value is specified at Ta = 25°C and V_{DD} = -5V.

AC Characteristics

($V_{DD} = -5V \pm 10\%$, $T_a = -20$ to $+70^\circ C$)

Parameter	Symbol	Conditions	MIN.	TYP.	MAX.	Unit	Note
Clock frequency	f_ϕ				2	MHz	
Clock pulse width	$t_{\phi}, t_{\bar{\phi}}$		250			ns	
D_{IN} setup time	t_{DS}		60			ns	
D_{IN} hold time	t_{DH}		60			ns	
LS pulse width	t_{LP}		150			ns	
Clock to LS delay	t_{CL}		0			ns	
LS to clock delay	t_{LC}		0			ns	
D_{OUT} delay	t_{PD}	$C_L (D_{OUT}) = 30pF$			250	ns	
LS to STB delay	t_{LSB}		0			ns	
LS to CL delay	t_{LCL}		0			ns	
STB pulse width	t_{SP}		1			μs	
CL pulse width	t_{CLP}		1			μs	
HVO fall time	t_{PL}	$C_L (HVO) = 900pF, R_L = 20k\Omega$			60	μs	1
HVO rise time	t_{PH}	$C_L (HVO) = 900pF, R_L = 20k\Omega$			15	μs	

Note 1 : Output delay time varies depending on load condition.

Test conditions

Input pulse level : 0.8 to 2.4V

Input rise/fall time : 20ns

Time measurement level : 50%

HVO output load conditions (figure at right).

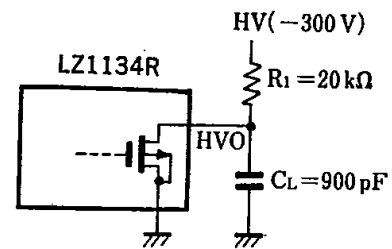

Capacitance

($V_{DD} = 0V, f = 1MHz, T_a = 25^\circ C$)

Parameter	Symbol	Conditions	MIN.	TYP.	MAX.	Unit
Input capacitance	C_{IN}	$V_{IN} = 0V$		6	10	pF
Output capacitance	C_{HVO}	$V_{HVO} = 0V$		17	30	pF

All pins except for the pin under measurement are grounded.

AC Timing Diagram

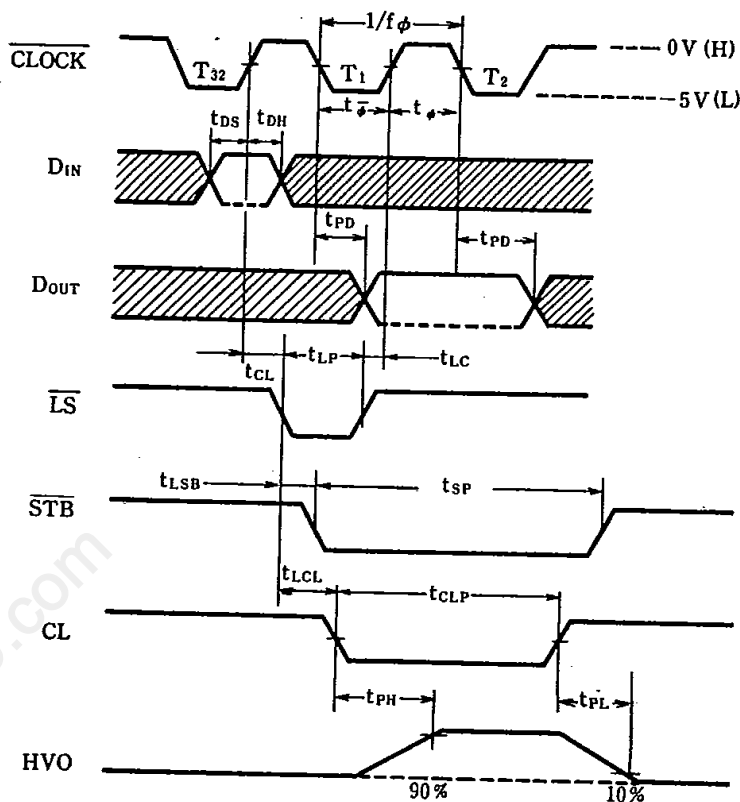

SHARP